

# **Bonfiglioli** Riduttori

---

## V series

Motovariatori

---

Motovariator

---

Verstellgetriebemotoren

---

Motovariateurs

---

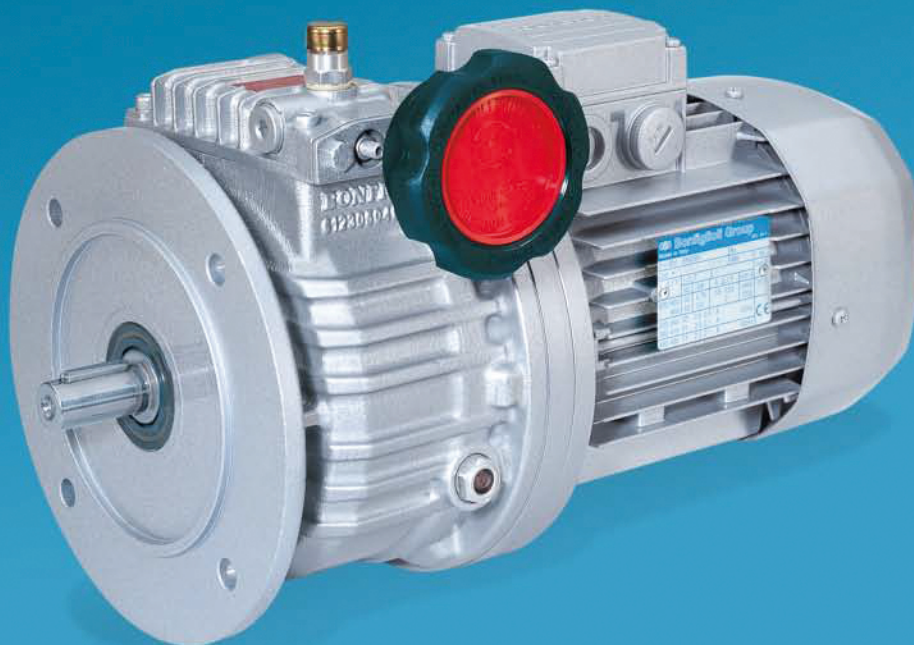





**INFORMAZIONI GENERALI**  
**GENERAL INFORMATION**  
**ALLGEMEINE INFORMATIONEN**  
**INFORMATIONS GENERALES**

Paragrafo Heading Abschnitt Paragraphe	Descrizione	Description	Beschreibung	Description	
1	Simbologia e unità di misura	<i>Symbols and units of measure</i>	Verwendete Symbole und Einheiten	<i>Symboles et unités de mesure</i>	2
2	Coppia in uscita	<i>Output torque</i>	Abtriebsmoment	<i>Couple en sortie</i>	4
3	Potenza nominale	<i>Rated power</i>	Nenn-Leistung	<i>Puissance nominale</i>	5
4	Potenza termica	<i>Thermal capacity</i>	Wärmeleistung	<i>Puissance thermique</i>	5
5	Rapporto di riduzione	<i>Gear ratio</i>	Übersetzung	<i>Rapport de réduction</i>	6
6	Velocità angolare	<i>Speed</i>	Drehzahl	<i>Vitesse angulaire</i>	6
7	Fattore di servizio	<i>Service factor</i>	Betriebsfaktor	<i>Facteur de service</i>	7
8	Carichi radiali	<i>Radial loads</i>	Radialkräfte	<i>Charges radiales</i>	8
9	Carichi assiali	<i>Thrust loads</i>	Axialkräfte	<i>Charges axiales</i>	9
10	Lubrificazione riduttori	<i>Gearbox lubrication</i>	Schmierung des Getriebes	<i>Lubrification des réducteurs</i>	10
11	Manutenzione	<i>Maintenance</i>	Wartung	<i>Entretien</i>	11
12	Scelta	<i>Selection</i>	Antriebsauswahl	<i>Sélection</i>	12
13	Verifiche	<i>Verification</i>	Prüfungen	<i>Vérifications</i>	15
14	Installazione	<i>Installation</i>	Installation	<i>Installation</i>	16
15	Stoccaggio	<i>Storage</i>	Lagerung	<i>Stockage</i>	17
16	Condizioni di fornitura	<i>Supply conditions</i>	Lieferbedingungen	<i>Conditions de livraison</i>	18
17	Specifiche della vernice	<i>Paint specifications</i>	Angaben zu den anstrichstoffe	<i>Specifications de la peinture</i>	18

**MOTOVARIATORI SERIE V**  
**MOTOVARIATOR V SERIES**  
**VERSTELLGETRIEBEMOTOREN - SERIE V**  
**MOTOVARIATEURS SERIES V**

18	Motovariatori serie V	<i>Motovariator V series</i>	Verstelltriebemotoren - serie V	<i>Motovariateurs series V</i>	19
19	Variatori V con motore a standard NEMA	<i>V variators with NEMA motors</i>	Verstellgetriebe V gemäss NEMA - Normen	<i>Variateurs V avec moteurs a normes NEMA</i>	82
20	Accessori	<i>Accessories</i>	Zubehör	<i>Accessoires</i>	88
21	Motovariariduttori serie V+S	<i>Motorized geared variator V+S</i>	Verstelltriebemotoren V+S	<i>Motovariareducteurs series V+S</i>	95
22	Motovariariduttori serie V+C	<i>Motorized geared variator V+C</i>	Verstelltriebemotoren V+C	<i>Motovariareducteurs series V+C</i>	133
23	Motovariariduttori serie V+VF-W	<i>Motorized geared variator V+VF-W</i>	Verstelltriebemotoren V+VF-W	<i>Motovariareducteurs series V+VF-W</i>	205

**MOTORI ELETTRICI**  
**ELECTRIC MOTORS**  
**ELEKTROMOTOREN**  
**MOTEURS ELECTRIQUES**

M1	Programma di produzione	<i>Production Planning</i>	Produktionsprogramm	<i>Programme de production</i>	287
M2	Normative	<i>Reference standards</i>	Normen	<i>Normes</i>	287
M3	Tolleranze	<i>Tolerances</i>	Toleranzen	<i>Tolerances</i>	289
M4	Senso di rotazione	<i>Direction of rotation</i>	Drehrichtung	<i>Sens de rotation</i>	290
M5	Cuscinetti	<i>Bearings</i>	Lager	<i>Roulements</i>	290
M6	Operatività standard	<i>Standard operation</i>	Standardversorgung	<i>Conditions operatives</i>	291
M7	Funzionamento a 60 Hz	<i>60 Hz operation</i>	Betrieb bei a 60 Hz	<i>Fonctionnement a 60 Hz</i>	292
M8	Alimentazione da inverter	<i>Inverter control</i>	Frequenzumrichterbetrieb	<i>Alimentation par variateur</i>	296
M9	Tipo di servizio	<i>Type of duty</i>	Betriebsarten	<i>Type de service</i>	298
M10	Morsetiera motore	<i>Terminal box</i>	Motorklemmenkasten	<i>Bornier moteur</i>	300
M11	Forme costruttive	<i>Design version</i>	Bauformen	<i>Formes de construction</i>	301
M12	Ventilazione	<i>Ventilation</i>	Kühlung	<i>Ventilation</i>	303
M13	Designazione motore	<i>Motor designation</i>	Motorbezeichnung	<i>Designation moteur</i>	306
M14	Varianti e opzioni	<i>Variants and options</i>	Optionen	<i>Variantes et options</i>	307
M15	Grado di protezione	<i>Degree of protection</i>	Schutzart	<i>Degre de protection</i>	308
M16	Classe di isolamento	<i>Insulation class</i>	Isolationsklasse	<i>Classes d'isolation</i>	310
M17	Protezioni termiche	<i>Thermal protective devices</i>	Thermische Wicklungsschutzeinricht	<i>Protections thermiques</i>	311
M18	Dispositivi di retroazione	<i>Feedback units</i>	Encoder / Inkrementalgeber	<i>Dispositifs de retroaction</i>	312
M19	Riscaldatori anticondensa	<i>Anti-condensation heaters</i>	Wicklungsheizung	<i>Rechauffeurs anticondensation</i>	314
M20	Tropicalizzazione	<i>Tropicalization</i>	Tropenschutz	<i>Tropicalisation</i>	314
M21	Esecuzioni albero motore	<i>Rotor shaft configurations</i>	Option der rotorwelle	<i>Executions arbre rotor</i>	314
M22	Equilibratura rotore	<i>Rotor balancing</i>	Rotorauswuchtung	<i>Equilibrage du rotor</i>	315
M23	Protezioni meccaniche esterne	<i>External mechanical protections</i>	Mechanische Schutzvorrichtungen	<i>Protections mecaniques exterieures</i>	316
M24	Motori asincroni autofrenanti	<i>Asynchronous brake motors</i>	Drehstrombremsmotoren	<i>Moteurs frein asynchrones</i>	317
M25	Motori autofrenanti in C.C., tipo BN_FD	<i>DC brake motors type BN_FD</i>	Wechselstrom-Bremsmotoren mit G.S.- Bremsse Typ BN_FD	<i>Moteurs frein en C.C., type BN_FD</i>	323
M26	Motori autofrenanti in C.A., tipo BN_FA	<i>AC brake motors type BN_FA</i>	Wechselstrom-Bremsmotoren mit W.S.- Bremsse Typ BN_FA	<i>Moteurs frein en C.A., type BN_FA</i>	329
M27	Motori autofrenanti in C.A., tipo BN_BA	<i>AC brake motors type BN_BA</i>	Wechselstrom-Bremsmotoren mit W.S.- Bremsse Typ BN_BA	<i>Moteurs frein en C.A., type BN_BA</i>	333
M28	Dati tecnici motori	<i>Motor rating charts</i>	Motorenauswahl Tabellen	<i>Données techniques des moteurs</i>	337
M29	Dimensioni	<i>Dimensions</i>	Abmessungen	<i>Dimensions</i>	349

Revisióni  
L'indice di revisione del catalogo è riportato a pag. 358.  
Al sito [www.bonfiglioli.com](http://www.bonfiglioli.com) sono disponibili i cataloghi con le revisioni aggiornate.

Revisions  
Refer to page 358 for the catalogue revision index.  
Visit [www.bonfiglioli.com](http://www.bonfiglioli.com) to search for catalogues with latest revision index.

Änderungen  
Das Revisionsverzeichnis des Katalogs wird auf Seite 358 wiedergegeben. Auf unserer Website [www.bonfiglioli.com](http://www.bonfiglioli.com) werden die Kataloge in ihrer letzten, überarbeiteten Version angeboten.

Révisions  
Le sommaire de révision du catalogue est indiqué à la page 358.  
Sur le site [www.bonfiglioli.com](http://www.bonfiglioli.com) des catalogues avec les dernières révisions sont disponibles.

**1.0 - SIMBOLOGIA  
E UNITÀ DI MISURA**
**1.0 - SYMBOLS AND  
UNITS OF MEASURE**
**1.0 - VERWENDETE  
SYMBOLE  
UND EINHEITEN**
**1.0 - SYMBOLES ET UNITES  
DE MESURE**

Simb. Symb.	U.m. Meßeinh.	Descrizione	Description	Beschreibung	Description
<b>A<sub>N2</sub></b>	[N]	Carico assiale nominale	<i>Permissible axial force</i>	Nenn-Axialbelastung	<i>Charge axiale nominale</i>
<b>f<sub>m</sub></b>	–	Fattore di maggiorazione	<i>Increased power factor</i>	Überdimensionierungsfaktor	<i>Facteur de majoration</i>
<b>f<sub>s</sub></b>	–	Fattore di servizio	<i>Service factor</i>	Betriebsfaktor	<i>Facteur de service</i>
<b>f<sub>T</sub></b>	–	Fattore termico	<i>Thermal factor</i>	Wärmefaktor	<i>Facteur thermique</i>
<b>f<sub>TP</sub></b>	–	Fattore di temperatura	<i>Temperature factor</i>	Temperaturfaktor	<i>Facteur de température</i>
<b>i</b>	–	Rapporto di trasmissione	<i>Gear ratio</i>	Übersetzung	<i>Rapport de réduction</i>
<b>I</b>	–	Rapporto di intermittenza	<i>Cyclic duration factor</i>	Relative Einschaltzeit	<i>Rapport d'intermittence</i>
<b>J<sub>C</sub></b>	[Kgm <sup>2</sup> ]	Momento di inerzia carico	<i>Mass moment of inertia of the driven equipment</i>	Massenträgheitsmoment der externen Massen	<i>Moment d'inertie de la charge</i>
<b>J<sub>M</sub></b>	[Kgm <sup>2</sup> ]	Momento di inerzia motore	<i>Motor mass moment of inertia</i>	Motorträgheitsmoment	<i>Moment d'inertie du moteur</i>
<b>J<sub>R</sub></b>	[Kgm <sup>2</sup> ]	Momento di inerzia riduttore	<i>Mass moment of inertia for the gear unit</i>	Getriebeträgheitsmoment	<i>Moment d'inertie du réducteur</i>
<b>K</b>	–	Fattore di accelerazione delle masse	<i>Mass acceleration factor</i>	Massenbeschleunigungsfaktor	<i>Facteur d'accélération des masses</i>
<b>K<sub>r</sub></b>	–	Costante di trasmissione	<i>Transmission element factor</i>	Belastungsfaktor der Radiallast	<i>Constante de transmission</i>
<b>M<sub>1, 2</sub></b>	[Nm]	Coppia	<i>Torque</i>	Drehmoment	<i>Couple</i>
<b>M<sub>2max</sub></b>	[Nm]	Coppia max trasmessa	<i>Max transmitted torque</i>	Max. übertragenes Drehmoment	<i>Couple maxi. transmis</i>
<b>M<sub>c 1, 2</sub></b>	[Nm]	Coppia di calcolo	<i>Calculated torque</i>	Berechnetes Drehmoment	<i>Couple de calcul</i>
<b>M<sub>n 1, 2</sub></b>	[Nm]	Coppia nominale	<i>Rated torque</i>	Nennmoment	<i>Couple nominal</i>
<b>M<sub>r 1, 2</sub></b>	[Nm]	Coppia richiesta	<i>Torque demand</i>	Benötigtes Drehmoment	<i>Couple nécessaire</i>
<b>n<sub>1, 2</sub></b>	[min <sup>-1</sup> ]	Velocità	<i>Speed</i>	Abtriebsdrehzahl	<i>Vitesse</i>
<b>P<sub>1, 2</sub></b>	[kW]	Potenza	<i>Power</i>	Leistung	<i>Puissance</i>
<b>P<sub>N 1, 2</sub></b>	[kW]	Potenza nominale	<i>Rated power</i>	Nennleistung	<i>Puissance nominale</i>
<b>P<sub>R 1, 2</sub></b>	[kW]	Potenza richiesta	<i>Power demand</i>	Benötigte Leistung	<i>Puissance nécessaire</i>
<b>R<sub>c 1, 2</sub></b>	[N]	Carico radiale di calcolo	<i>Calculated radial force</i>	Berechnete Axialbelastung	<i>Charge radiale de calcul</i>
<b>R<sub>N 1, 2</sub></b>	[N]	Carico radiale nominale	<i>Permissible overhung load</i>	Zulässige Radialbelastung	<i>Charge radiale nominale</i>
<b>S</b>	–	Fattore di sicurezza	<i>Safety factor</i>	Sicherheitsfaktor	<i>Facteur de sécurité</i>
<b>t<sub>a</sub></b>	[°C]	Temperatura ambiente	<i>Ambient temperature</i>	Umgebungstemperatur	<i>Température ambiante</i>
<b>t<sub>f</sub></b>	[min]	Tempo di funzionamento a carico costante	<i>Work time at constant load</i>	Betriebszeit während nennbetrieb	<i>Temps de fonctionnement à charge constante</i>
<b>t<sub>r</sub></b>	[min]	Tempo di riposo	<i>Rest time</i>	Stillstandszeit	<i>Temps de repos</i>
<b>η<sub>D</sub></b>		Rendimento dinamico	<i>Dynamic efficiency</i>	Dynamischer Wirkungsgrad	<i>Rendement dynamique</i>
<b>η<sub>S</sub></b>		Rendimento statico	<i>Static efficiency</i>	Statischer Wirkungsgrad	<i>Rendement statique</i>
1	valore riferito all'albero veloce	1	<i>value applies to i/p shaft</i>	1	<i>valeurs pour l'arbre rapide</i>
2	valore riferito all'albero lento	2	<i>value applies to o/p shaft</i>	2	<i>valeurs pour l'arbre lent</i>



Questo simbolo riporta i riferimenti angolari per l'indicazione della direzione del carico radiale (l'albero è visto di fronte).



*This symbol indicates the radial load direction angle references. (shaft front-view).*



Dieses Symbol gibt die Winkelbezugswerte für die Angabe der Richtung der Radialkräfte an (Stirnsicht der Welle).



*Ce symbole présente les références angulaires pour l'indication de la direction de la charge radiale (l'arbre est vu de face).*



Le colonne contrassegnate da questo simbolo indicano i numeri di pagina dove sono riportate le dimensioni.



*Columns marked with this symbol indicate the reference page showing the dimensions.*



Die mit diesem Symbol gekennzeichneten Spalten geben die Nummern der Seiten mit den Maßangaben der gewählten.



*Les colonnes portant ce symbole indiquent les numéros de page où sont mentionnées les dimensions.*

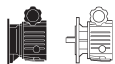

Motore variatore in esecuzione compatta e flangiata

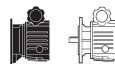

*Compact motor variator with flanged output*

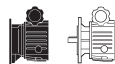

Verstelltriebemotor in kompakter und geflanschter Version.

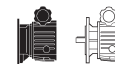

*Motore variatore esecuzione compatta avec bride.*



Motore elettrico con flangia IEC (B5 o B5R).



*Electric motor with IEC flange (B5 or B5R).*



Elektromotor mit Flansch IEC (B5 oder B5R).



*Motore électrique avec bride IEC (B5 ou B5R).*



Riduttore monostadio serie S predisposto per accoppiamento al motore variatore compatto e flangiato.



*S single-stage gearbox to fit compact motor variator with flanged output.*



Einstufiges Getriebe der Serie S, vorbereitet für Passung an den kompakten und geflanschten Verstelltriebemotor.



*Réducteur à un étage série S prédisposé pour l'accouplement au motovariateur compact et avec bride.*

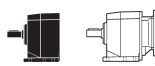

Riduttore coassiale serie C predisposto per accoppiamento al motore variatore compatto e flangiato.

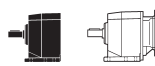

*C in-line gearbox to fit compact motor variator with flanged output.*

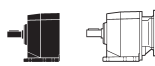

Stirnrädergetriebe der Serie C, vorbereitet für Passung an den kompakten und geflanschten Verstelltriebemotor.

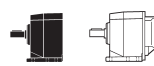

*Réducteur coaxial série C prédisposé pour l'accouplement au motovariateur compact et avec bride.*



Riduttore a vite senza fine serie VF o W predisposto per accoppiamento al motore variatore compatto e flangiato.



*VF or W worm gearbox to fit compact motor variator with flanged output.*

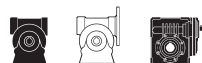

Schneckengetriebe der Serie VF oder W, vorbereitet für Passung an den kompakten und geflanschten Verstelltriebemotor.



*Réducteur à vis sans fin série VF ou W prédisposé pour l'accouplement au motovariateur compact et avec bride.*

**INFORMAZIONI GENERALI**

I paragrafi che seguono riportano una serie di informazioni sugli elementi indispensabili per la scelta e il corretto utilizzo dei motovariariduttori. Indicazioni specifiche relative alle varie tipologie di riduttori potranno essere ricercate nei capitoli di pertinenza.

**2.0 - COPPIA IN USCITA****2.1 - Coppia nominale**  
 $M_{n2}, M_{n2}'$  [Nm]

È la coppia trasmissibile in uscita con carico continuo uniforme riferita alla velocità in ingresso  $n_1$  e a quella corrispondente in uscita  $n_2, n_2'$ . È calcolata in base ad un fattore di servizio  $f_s = 1$ .

**2.2 - Coppia richiesta**  
 $M_{r2}, M_{r2}'$  [Nm]

Rappresenta la coppia richiesta dall'applicazione e dovrà sempre essere uguale o inferiore alla coppia in uscita nominale  $M_{n2}, M_{n2}'$  del riduttore scelto.

**2.3 Coppia di calcolo**  
 $M_{c2}, M_{c2}'$  [Nm]

È il valore di coppia da utilizzare per la selezione del motovariariduttore considerando la coppia richiesta  $M_{r2}$  (alla velocità  $n_2, n_2'$  desiderata) e il fattore di servizio  $f_s$  ed è dato dalla formula

$$M_{c2} = M_{r2} \cdot f_s \leq M_{n2}$$

Nei riduttori a vite senza fine, in funzione del particolare cinematismo che determina una trasmissione del moto con un accentuato strisciamento, è necessario rivalutare la coppia di calcolo  $M_{c2}$  in base al fattore di temperatura  $f_{tp}$  che in questo tipo di riduttori ha un'incidenza rilevante.

La formula (1) verrà modificata come segue:

$$M_{c2} = M_{r2} \cdot f_s \cdot f_{tp} \leq M_{n2}$$

La tabella (B1) riporta i valori di  $f_{tp}$  in base al tipo di carico K1, K2, K3 e alla temperatura ambiente riferiti ad una lubrificazione con lubrificante sintetico; fra parentesi sono indicati i valori da adottare nel caso venga utilizzato un lubrificante a base minerale.

**GENERAL INFORMATION**

The following headings contain information on essential elements for selection and correct use of motovariator-gearboxes. For specific data on the gearbox range, see the relevant chapters.

**2.0 - OUTPUT TORQUE****2.1 - Nominal output torque**  
 $M_{n2}, M_{n2}'$  [Nm]

Torque transmitted at the output shaft under uniform load, based on drive speed  $n_1$  and corresponding output speed  $n_2, n_2'$ . Nominal torque is based on service factor  $f_s = 1$ .

**2.2 - Required torque**  
 $M_{r2}, M_{r2}'$  [Nm]

This is the torque corresponding to application requirements. It must always be equal to or less than rated output torque  $M_{n2}, M_{n2}'$  of the selected gearbox.

**2.3 Calculated torque**  
 $M_{c2}, M_{c2}'$  [Nm]

This is the torque value to be used for selecting the motovariator-gearbox unit considering required torque  $M_{r2}$  (at required  $n_2, n_2'$  speed) and service factor  $f_s$ , and is obtained by applying formula

In the case of worm gearboxes, depending on the special movement providing drive transmission with pronounced slipping, the calculated torque  $M_{c2}$  must be reconsidered according to the temperature factor  $f_{tp}$  which has a marked influence in this type of gearbox. The formula (1) should be modified as follows:

**ALLGEMEINE INFORMATIONEN**

Die folgenden Abschnitte enthalten eine Reihe von Informationen über die Aspekte, die in Hinblick auf die Wahl und den sachgemäßen Betrieb von Verstellgetriebe bemotors unbedingt zu berücksichtigen sind. Die spezifische Informationen über die verschiedenen Getriebearten sind den zugehörigen Kapiteln zu entnehmen.

**2.0 - ABTRIEBSMOMENT****2.1 - Nenn-Drehmoment**  
 $M_{n2}, M_{n2}'$  [Nm]

Dies ist das an der Abtriebswelle übertragbare Drehmoment bei gleichförmiger Dauerbelastung bezogen auf die Antriebsdrehzahl  $n_1$  und die entsprechende Abtriebsdrehzahl  $n_2, n_2'$ . Das Drehmoment wird auf Grundlage eines Betriebsfaktor  $f_s = 1$  berechnet.

**2.2 - Verlangtes Drehmoment**  
 $M_{r2}, M_{r2}'$  [Nm]

Dies ist das von der Anwendung verlangte Drehmoment, das stets kleiner oder gleich dem Nenn- Abtriebsmoment  $M_{n2}, M_{n2}'$  des gewählten Getriebes sein muß.

**2.3 Soll-Drehmoment**  
 $M_{c2}, M_{c2}'$  [Nm]

Dies ist das bei der Wahl des Getriebes zugrundezulegende Drehmoment, wobei das übertragene Drehmoment  $M_{r2}$  und der Betriebsfaktor  $f_s$  zu berücksichtigen sind; das Soll-Drehmoment wird mit folgender Gleichung berechnet:

Auf den Schneckengetrieben muß wegen des speziellen Getriebes, das eine stark abwägende Bewegungsübertragung verursacht, das Soll-Drehmoment  $M_{c2}$  unter Bezugnahme des Temperaturfaktors  $f_{tp}$  neu berechnet werden. Dieser hat in Getrieben dieser Art eine wesentliche Bedeutung. Die Formel (1) wird wie folgt verändert:

**INFORMATIONS GENERALES**

Les paragraphes qui suivent présentent une série d'informations sur les éléments indispensables pour le choix et l'utilisation correcte des motovariaréducteurs. Des indications spécifiques relatives aux différentes typologies de réducteurs pourront être recherchées dans les chapitres respectifs.

**2.0 - COUPLE EN SORTIE****2.1 - Couple nominal**  
 $M_{n2}, M_{n2}'$  [Nm]

C'est le couple transmissible en sortie avec une charge continue uniforme se référant à la vitesse en entrée  $n_1$  et à celle correspondante en sortie  $n_2, n_2'$ . Il est calculé sur la base d'un facteur de service  $f_s = 1$ .

**2.2 - Couple requis**  
 $M_{r2}, M_{r2}'$  [Nm]

Il représente le couple requis par l'application et devra toujours être inférieur ou égal au couple en sortie nominal  $M_{n2}, M_{n2}'$  du réducteur choisi.

**2.3 Couple de calcul**  
 $M_{c2}, M_{c2}'$  [Nm]

C'est la valeur de couple à utiliser pour la sélection du réducteur en considérant le couple requis  $M_{r2}$  et le facteur de service  $f_s$  et s'obtient avec la formule

(1)

Sur les réducteurs à vis sans fin, en fonction de l'organe de mouvement qui détermine une transmission du mouvement avec un frottement accentué, il est nécessaire de redéfinir le couple de calcul  $M_{c2}$  sur la base du facteur de température  $f_{tp}$ , qui a une grande importance sur ce type de réducteur. La formule (1) sera modifiée de la façon suivante :

(2)

Le tableau (B1) indique les valeurs de  $f_{tp}$  sur la base du type de charge K1, K2, K3 et à température ambiante avec lubrifiant synthétique. Les valeurs à adopter avec lubrifiant minérale sont indiquées entre parenthèses.



(B1)

Fattore di temperatura / Temperature factor / Temperaturfaktor / Facteur de température						
Tipo di carico / Load pattern Belastung / Type de charge			Temperatura ambiente / Ambient temperature Umgebungstemperatur / Température ambiante			
			20 °C	30 °C	40 °C	50 °C
<b>K1</b>	Carico uniforme Gleichmäßige Belastung	Uniform load Charge uniforme	1.00 (1.00)	1.00 (1.04)	1.06 (1.20)	1.20 (1.50)
<b>K2</b>	Carico con urti moderati Belastung mit mäßigen Stößen	Moderate shock load Charge avec chocs modérés	1.00 (1.00)	1.02 (1.07)	1.12 (1.28)	1.30 (1.70)
<b>K3</b>	Carico con forti urti Belastung mit starken Stößen	Heavy shock load Charge avec chocs violents	1.00 (1.00)	1.04 (1.08)	1.17 (1.33)	1.40 (1.90)

**3.0 - POTENZA NOMINALE**  
**P<sub>n1</sub> [kW]**

Nelle tabelle di selezione dei motovariatori è la potenza applicata in entrata riferita alla velocità  $n_1$  e considerando un fattore di servizio  $f_s=1$ .

**3.0 - RATED POWER**  
**P<sub>n1</sub> [kW]**

*In the motovariator-gearboxes selection charts, this is the applicable input power referred to speed  $n_1$  and considering a service factor  $f_s=1$ .*

**3.0 - NENN-LEISTUNG**  
**P<sub>n1</sub> [kW]**

In den Tabellen für die Wahl der Verstelltriebemotors ist die an der Antriebswelle übertragbare Leistung auf die Drehzahl  $n_1$  bezogen und es wurde ein Betriebsfaktor  $f_s=1$  angenommen.

**3.0 - PUISSANCE NOMINAL**  
**P<sub>n1</sub> [kW]**

*Dans les tableaux de sélection des motovariateurs, c'est la puissance applicable en entrée se rapportant à la vitesse  $n_1$  et en considérant un facteur de service  $f_s=1$ .*

**4.0 - POTENZA TERMICA**  
**P<sub>t</sub> [kW]**

È il valore che indica il limite termico del riduttore ed è la potenza trasmissibile in servizio continuo ad una temperatura ambiente massima di 20°C senza ricorrere ad un raffreddamento ausiliare. Per un tipo di servizio caratterizzato da una breve durata di funzionamento e da un tempo di sosta sufficientemente lungo da consentire il raffreddamento del gruppo, la potenza termica acquista scarsa rilevanza per cui può non essere tenuta in considerazione. Se la temperatura ambiente è diversa da 20°C e se il servizio è intermittente, è possibile correggere il valore di  $P_t$  in base ai fattori termici  $f_t$  riportati nella tabella (B3) verificando però che sia sempre soddisfatta la condizione:

**4.0 - THERMAL CAPACITY**  
**P<sub>t</sub> [kW]**

*This value indicates the gearbox's thermal limit and corresponds to the power transmission capacity under continuous duty at a maximum ambient temperature of 20°C without using a supplementary cooling facility. For a duty with short operating periods and sufficiently long pauses to allow the unit to cool, thermal power is not particularly important and therefore it does not need to be taken into consideration. If ambient temperature is different from 20°C and duty is intermittent,  $P_t$  value can be adjusted according to thermal factors  $f_t$  shown in tables (B3) provided you check that the following condition is always satisfied:*

**4.0 - WÄRMELEISTUNG**  
**P<sub>t</sub> [kW]**

Dieser Wert steht für die Wärmegrenzleistung des Getriebes und die im Dauerbetrieb übertragbare Leistung bei einer Umgebungstemperatur von 20°C ohne Zusatzkühlung. Bei einem Betrieb, der sich durch eine kurzzeitige Betriebsdauer und eine für die Abkühlung der Gruppe ausreichend lang andauernde Aussetzzeit kennzeichnet, ist die Wärmeleistung von geringer Bedeutung und braucht daher nicht unbedingt berücksichtigt zu werden. Bei einer unter 20°C liegenden Umgebungstemperatur und im Fall eines Aussetzbetriebs kann der Wert  $P_t$  den Wärmefaktoren  $f_t$ , die in der Tabelle (B3) aufgeführt werden, gemäß berechnet werden. Dabei ist jedoch zu überprüfen, ob die folgende Bedingung immer gegeben ist.

**4.0 - PUISSANCE THERMIQUE**  
**P<sub>t</sub> [kW]**

*C'est la valeur qui indique la limite thermique du réducteur et c'est la puissance transmissible en service continu, à une température ambiante maximum de 20°C sans recourir à un refroidissement auxiliaire. Pour un type de service caractérisé par une durée de fonctionnement brève et par un temps de pause suffisamment long pour permettre le refroidissement du groupe, la puissance thermique ne revêt qu'une faible importance et peut, par conséquent, ne pas être prise en considération. En cas de température ambiante inférieure à 20°C, en service intermittent, il est possible de majorer la valeur de  $P_t$  en fonction des facteurs thermiques  $f_t$  indiqués dans le tableau (B3), en vérifiant que l'équation suivante soit toujours respectée.*

$$P_{r1} \leq P_t \cdot f_t \quad (3)$$

La tabella (B2) indica i valori della potenza termica attribuiti ai vari tipi di riduttori.

*Table (B2) indicates thermal power values according to type of gearbox.*

Die Tabelle (B2) zeigt die Werte der thermischen Grenzleistung für die verschiedenen Getriebetypen.

*Le tableau (B2) indique les valeurs de la puissance thermique, assignées aux divers types de réducteurs.*

Per i tipi di riduttore e per i rapporti non indicati, la potenza termica è superiore alla potenza meccanica pertanto non va tenuta in considerazione nelle verifiche.

*With regard to gearboxes and ratios not shown in the table, in such cases thermal power exceeds mechanical power, therefore it does not need to be considered when checking.*

Im Fall von Getriebe und nicht in die Tabelle angegebenen Überprüfungen nicht in Betracht zu ziehen.

*Pour les types de réducteur et pour les rapports non indiqués, la puissance thermique est supérieure à la puissance mécanique; par la suite on ne devra pas la considérer au moment de la vérification.*

(B2)

$n_1$ [min <sup>-1</sup> ]	P <sub>t</sub> [kW] 20°C											
	S					C (i ≤ 45)						
	10 1	20 1	30 1	40 1	50 1	11 2	21 2	31 2	35 2	41 2	51 2	61 2
<b>1400</b>	5.5	7.8	10.0	15.6	21	—	—	—	6.5	8.0	11.0	14.0
<b>2800</b>	4.9	7.2	9.1	14.3	18.9	—	—	4.5	5.0	6.0	7.8	10.0



(B3)

		$f_t$			
$t_a$	Serv. continuo Continuous duty Dauerbetrieb Serv. continu	Servizio intermittente / Intermittent duty Aussetzbetrieb / Service intermittent			
		Rapporto di intermittenza (I) Cyclic duration factor (I) Relative Einschaltdauer (I) Rapport d'intermittence (I)			
		80%	60%	40%	20%
40 °C	0.8	1.1	1.3	1.5	1.6
30 °C	0.85	1.3	1.5	1.6	1.8
20 °C	1.0	1.5	1.6	1.8	2.0
10 °C	1.15	1.6	1.8	2.0	2.3

Il rapporto di intermittenza (I)% è dato dal rapporto fra il tempo di funzionamento a carico  $t_f$  e il tempo totale espresso in percentuale:

*The cyclic duration factor (I)% is obtained from the ratio operating time under load  $t_f$  with respect to total time expressed as a percentage:*

Die relative Einschaltdauer (I)% ist das Verhältnis aus der Betriebsdauer unter Last  $t_f$  und der Gesamtbetriebszeit, ausgedrückt in Prozent:

*Le rapport d'intermittence (I)% est donné par le rapport entre la durée de fonctionnement en charge  $t_f$  et le temps total exprimé en pourcentage:*

$$I = \frac{t_f}{t_f + t_r} \cdot 100$$

(4)

#### 5.0 - RAPPORTO DI RIDUZIONE

È una caratteristica del riduttore la cui identificazione si ha nel rapporto:

#### 5.0 - GEAR RATIO

*A gearbox inherent feature, obtained from the following equation:*

#### 5.0 - ÜBERSETZUNG

Dieses Merkmal des Getriebes wird durch das folgende Verhältnis ausgedrückt:

#### 5.0 - RAPPORT DE REDUCTION

*C'est une caractéristique du réducteur dont l'identification est obtenue avec l'équation:*

$$i = \frac{n_1}{n_2}$$

(5)

#### 6.0 - VELOCITÀ ANGOLARE

#### 6.1 - Velocità in entrata $n_1$ [ $\text{min}^{-1}$ ]

È la velocità relativa al tipo di motorizzazione scelta; i valori di catalogo si riferiscono alle velocità dei motori elettrici comunemente usati.

#### 6.0 - SPEED

#### 6.1 - Input speed $n_1$ [ $\text{min}^{-1}$ ]

*Speed is related to the type of drive unit selected. Catalogue values refer to speed of electric motors normally used.*

#### 6.0 - DREHZAHL

#### 6.1 - Drehzahl Antriebswelle $n_1$ [ $\text{min}^{-1}$ ]

Dies ist die vom gewählten Motortyp abhängige Drehzahl. Die Katalogangaben beziehen sich auf die Drehzahl von allgemein-üblichen eintourigen Elektromotoren.

#### 6.0 - VITESSE ANGULAIRE

#### 6.1 - Vitesse d'entrée $n_1$ [ $\text{min}^{-1}$ ]

*C'est la vitesse relative au type de motorisation choisie. Les valeurs de catalogue se réfèrent aux vitesses des moteurs électriques communément utilisés.*

#### 6.2 - Velocità in uscita $n_2$ [ $\text{min}^{-1}$ ]

È in funzione della velocità in entrata  $n_1$  e del rapporto di riduzione  $i$  secondo la relazione

#### 6.2 - Output speed $n_2$ [ $\text{min}^{-1}$ ]

*Calculated from input speed  $n_1$  and transmission ratio  $i$  according to the following equation*

#### 6.2 - Abtriebsdrehzahl $n_2$ [ $\text{min}^{-1}$ ]

Sie ist abhängig von der Antriebsdrehzahl  $n_1$  und dem Übersetzungs  $i$  nach folgender Gleichung:

#### 6.2 - Vitesse en sortie $n_2$ [ $\text{min}^{-1}$ ]

*Elle varie en fonction de la vitesse d'entrée  $n_1$  et du rapport de reduction  $i$  selon l'équation:*

$$n_2 = \frac{n_1}{i}$$

(6)





### 7.0 - FATTORE DI SERVIZIO $f_s$

È il fattore che tiene in considerazione, con sufficiente approssimazione, la variabilità del carico e gli eventuali urti a cui è sottoposto il riduttore per un determinato tipo di servizio. Nel grafico della tabella (B4), dall'intersezione della linea corrispondente al numero di inserzioni/ora (avviamenti e arresti) con una delle curve (K1, K2, K3), che identificano la natura del carico in funzione del fattore di accelerazione delle masse K, si potrà leggere nel grafico il valore del fattore di servizio  $f_s$  riferito al numero di ore di funzionamento giornaliere. Eventuali valori intermedi potranno essere ottenuti per interpolazione. Il valore di  $f_s$  ottenuto dovrà poi essere confrontato con il fattore di sicurezza S riportato nelle tabelle di selezione verificando la condizione:

### 7.0 - SERVICE FACTOR $f_s$

This factor takes into consideration, with sufficient approximation, load variations and eventual shocks the gearbox may undergo for a specific type of duty. In the diagram (B4), at the intersection of the line for the number of starts/stops per hour with one of the curves (K1, K2, K3) identifying the type of load based on the acceleration factor of masses K, the value of duty factor  $f_s$  is indicated as a function of daily operating hours. Intermediate values can be obtained by interpolation. The resulting  $f_s$  value is then cross-checked with the safety factor S reported in the selection charts to make sure this condition is satisfied:

### 7.0 - BETRIEBSFAKTOR $f_s$

Der Betriebsfaktor berücksichtigt mit hinreichender Annäherung die Lastschwankungen und eventuelle Stöße, denen das Getriebe unter bestimmten Anwendungsbedingungen ausgesetzt ist. In der Graphik von Tabelle (B4) kann man am Schnittpunkt der Senkrechten für die Schaltungen pro Stunde (Starts und Stopps) mit den Kurven (K1, K2, K3), die die Art der Belastung in Abhängigkeit vom Beschleunigungsfaktor der Massen K charakterisieren, den Betriebsfaktor  $f_s$  bezogen auf die täglichen Betriebsstunden ablesen. Eventuelle Zwischenwerte erhält man durch Interpolation. Der erhaltene Wert  $f_s$  muß daraufhin mit dem, in den Auswahl tabellen aufgeführten Sicherheitswert S verglichen werden, wobei folgende Bedingung überprüft werden muß:

### 7.0 - FACTEUR DE SERVICE $f_s$

C'est le facteur qui prend en considération avec une approximation suffisante, la variation de la charge et les éventuels chocs auxquels est soumis le réducteur pour un type de service déterminé. Sur le graphique du tableau (B4), à l'intersection de la ligne correspondant au nombre d'insertions/heure (démarrages et arrêts) avec l'une des courbes (K1, K2, K3) qui identifient la nature de la charge en fonction du facteur d'accélération des masses K, on pourra lire sur le graphique la valeur du facteur de service  $f_s$  se référant au nombre d'heures de fonctionnement quotidiennes. Les éventuelles valeurs intermédiaires pourront être obtenues par interpolation. La valeur de  $f_s$  obtenue devra ensuite être confrontée avec le facteur de sécurité S indiqué aux tableaux de sélection en vérifiant la condition :

$$S \geq f_s \quad (7)$$

(B4)

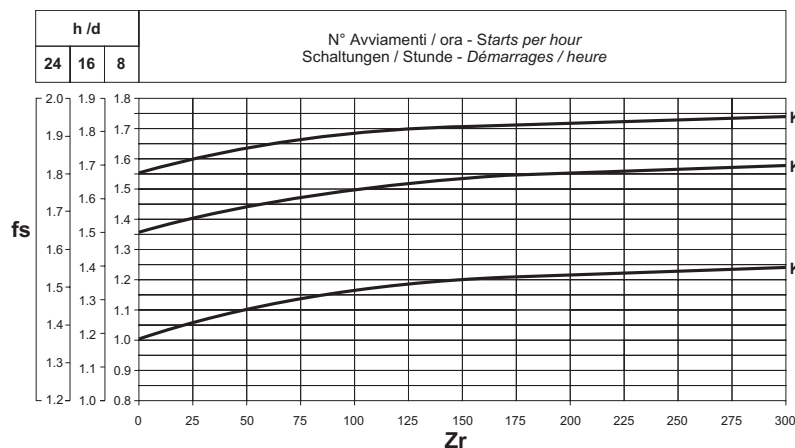

### 7.1 - Fattore di accelerazione delle masse K

Serve per la determinazione del fattore di servizio e si ricava dalla relazione:

### 7.1 - Acceleration factor of masses K

Used for establishing the service factor and calculated through the following equation:

### 7.1 - Beschleunigungsfaktor der Massen K

Dieser Faktor dient zur Bestimmung des Betriebsfaktors und ergibt sich aus folgender Gleichung:

### 7.1 - Facteur d'accélération des masses K

Il sert pour déterminer le facteur de service et s'obtient avec l'équation suivante :

$$K = \frac{J_c}{J_m} \quad (8)$$

dove:

$J_c$  [Kgm<sup>2</sup>] momento d'inerzia dinamico delle masse comandate rapportato alla velocità del motore applicato  
 $J_m$  [Kgm<sup>2</sup>] momento d'inerzia del motore

where:

$J_c$  [Kgm<sup>2</sup>] dynamic moment of inertia of the driven masses in proportion to the speed of the applied motor  
 $J_m$  [Kgm<sup>2</sup>] motor moment of inertia

wobei gilt:

$J_c$  [kgm<sup>2</sup>] dynamisches Trägheitsmoment der angetriebenen Massen, bezogen auf die Motordrehzahl;  
 $J_m$  [kgm<sup>2</sup>] Trägheitsmoment des Motors

où:

$J_c$  [Kgm<sup>2</sup>] est le moment d'inertie dynamique des masses entraînées rapporté à la vitesse du moteur appliqué  
 $J_m$  [Kgm<sup>2</sup>] est le moment d'inertie du moteur

- K1** carico uniforme  $K \leq 0.25$
- K2** carico con urti moderati  $0.25 < K \leq 3$
- K3** carico con forti urti  $3 < K \leq 10$

- K1** uniform load  $K \leq 0.25$
- K2** moderate shock load  $0.25 < K \leq 3$
- K3** heavy shock load  $3 < K \leq 10$

- K1** gleichmäßige Belastung  $K \leq 0.25$
- K2** Belastung mit mäßigen Stößen  $0.25 < K \leq 3$
- K3** Belastung mit starken Stößen  $3 < K \leq 10$

- K1** charge uniforme  $K \leq 0.25$
- K2** charge avec chocs modérés  $0.25 < K \leq 3$
- K3** charge avec chocs violents  $3 < K \leq 10$

Per valori di  $K > 10$  vi invitiamo a contattare il nostro Servizio Tecnico.

For  $K > 10$  values, please contact our Technical Service.

Bei Werten für  $K > 10$  bitte unseren Technischen Kundendienst zu Rate ziehen.

Pour les valeurs de  $K > 10$ , nous vous invitons à contacter notre Service Technique.



### 8.0 - CARICHI RADIALI

Gli alberi di entrata e uscita dei riduttori possono essere soggetti a carichi radiali (determinati dal tipo di trasmissione realizzata) la cui entità può essere calcolata con la formula:

### 8.0 - RADIAL LOADS

*Gearbox input and output shafts can be subjected to radial loads (determined by the type of transmission used) the extent of which can be calculated with the following formula:*

### 8.0 - RADIALKRÄFTE

Die Antriebs- und Abtriebswellen der Getriebe können Radialkräften ausgesetzt sein (die von der Übertragungsart abhängig sind), deren Ausmaß mit folgender Formel bestimmt werden kann:

### 8.0 - CHARGES RADIALES

*Les arbres d'entrée et de sortie des réducteurs peuvent être soumis à des charges radiales (déterminées par le type de transmission réalisée) dont l'entité peut être calculée avec la formule*

$$R_{c2} = \frac{2000 \cdot M_2 \cdot K}{d} \quad (9)$$

$R_{c2}$  Carico radiale (N)  
1 = su albero veloce  
2 = su albero lento  
 $M_2$  Coppia sull'albero (Nm)  
 $d$  Diametro (mm) della ruota per catena, ingranaggio, puleggia, ecc.  
 $K_r = 1$  Catena  
 $K_r = 1.25$  Ingranaggio  
 $K_r = 1.5 - 2.0$  Cinghia a V

$R_{c2}$  Radial load (N)  
1 = input shaft  
2 = output shaft  
 $M_2$  Torque (Nm)  
 $d$  Diameter (mm) of sprocket, gear, pulley, etc.  
 $K_r = 1$  Chain  
 $K_r = 1.25$  Gear  
 $K_r = 1.5-2.0$  V-belt

$R_{c2}$  Radialkraft (N)  
1 = auf Abtriebswelle  
2 = auf Abtriebswelle  
 $M_2$  Drehmoment an der Welle (Nm)  
 $d$  Durchmesser (mm) des Kettenrad, Zahnrad, Riemenscheibe, usw.  
 $K_r = 1$  Kettenrad  
 $K_r = 1,25$  Zahnrad  
 $K_r = 1,5 - 2,0$  V-Keilriemen

$R_{c2}$  Charge radiale (N)  
1 = sur arbre rapide  
2 = sur arbre lent  
 $M_2$  Couple sur l'arbre (Nm)  
 $d$  Diamètre (mm) de la roue à chaîne, engrenage, poulie, etc.  
 $K_r = 1$  Chaîne  
 $K_r = 1.25$  Engrenage  
 $K_r = 1.5 - 2.0$  Courroie en V

In base al punto di applicazione possiamo avere i seguenti casi:

*Depending on the application point the following cases are possible:*

In Abhängigkeit vom Kraftangriffspunkt können sich folgende Fälle ergeben:

*Suivant le point d'application nous pouvons avoir les cas suivants:*

a) applicazione del carico  $R_{c2}$  sulla mezziera dell'albero come indicato nella tabella (B5).  
Tale valore potrà essere confrontato direttamente con i dati delle tabelle rispettando la condizione

a) load  $R_{c2}$  applied on shaft mid-point as indicated in table (B5).  
*This value can be directly compared with table data by observing condition*

a) Kraftangriffspunkt  $R_{c2}$  auf der Mitte des Wellenendes wie in Abbildung (B5).  
Dieser Wert kann direkt mit den Daten der Tabelle verglichen werden, wobei folgende Bedingung zu beachten ist:

a) application de la charge  $R_{c2}$  au milieu de l'arbre comme indiqué sur la figure (B5).  
*Cette valeur pourra être directement comparée avec les données des tableaux en respectant la condition :*

$$R_{c2} \leq R_{n2} \quad (10)$$

b) applicazione del carico ad una distanza  $x$  dalla battuta dell'albero come indicato nella tabella (B6).  
La conversione del nuovo valore di carico radiale ammissibile  $R_{x2}$  è data dalla seguente relazione:

b) load applied at distance  $x$  from shaft shoulder as shown in table (B6).  
*Conversion to the new permitted radial load value  $R_{x2}$  is obtained from the following equation:*

b) Kraftangriffspunkt mit Abstand  $x$  vom Wellenansatz wie in Abbildung (B6).  
Die Konversion des neuen Werts der zulässigen Radialkraft  $R_{x2}$  wird durch folgende Gleichung gegeben:

b) application de la charge à une distance  $x$  de l'épaulement de l'arbre comme indiqué sur la figure (B6).  
*La conversion de la nouvelle valeur de charge radiale admissible  $R_{x2}$  s'obtient avec l'équation suivante :*

$$R_{x2} = R_{n2} \cdot \frac{a}{b+x} \quad (11)$$

valida per  $\frac{L}{2} < x < c$

valid for  $\frac{L}{2} < x < c$

gültig für  $\frac{L}{2} < x < c$

valable pour  $\frac{L}{2} < x < c$

$R_{n2}$  = Carico radiale ammissibile sulla mezziera dell'albero [N]  
 $a$  = costante del riduttore  
 $b$  = costante del riduttore  
 $c$  = costante del riduttore  
 $x$  = distanza del carico dalla battuta dell'albero (mm)

$R_{n2}$  = Permitted radial load on shaft mid-point [N]  
 $a$  = load location factor  
 $b$  = load location factor  
 $c$  = load location factor  
 $x$  = load offset (mm)

$R_{n2}$  = zulässige Radialkraft auf der Mitte des Wellenendes [N]  
 $a$  = Getriebekonstante  
 $b$  = Getriebekonstante  
 $c$  = Getriebekonstante  
 $x$  = Abstand des Kraftangriffspunktes vom Wellenansatz (mm)

$R_{n2}$  = Charge radiale admissible au milieu de l'arbre [N]  
 $a$  = constante du réducteur  
 $b$  = constante du réducteur  
 $c$  = constante du réducteur  
 $x$  = distance de la charge à partir de l'épaulement de l'arbre (mm)

(i valori delle costanti  $a, b, c$ , sono riportati nella tabella (B7)).  
Anche in questo caso, la condizione da verificare sarà la seguente:

*(factors values  $a, b, c$  are shown in table (B7)).  
The following condition must be checked in this case too:*

(die Werte der Konstanten  $a, b, c$  sind in Tabelle (B7) angegeben).  
Auch in diesem Fall ist folgende Bedingungen zu gewährleisten:

*(les valeurs des constantes  $a, b, c$ , sont rapportées dans le tableau (B7).  
Dans ce cas également, la condition à vérifier sera la suivante :*

$$R_{c2} \leq R_{x2} \quad (12)$$

(B5)

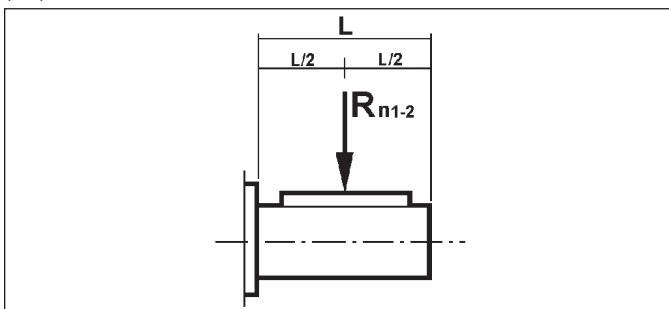

(B6)

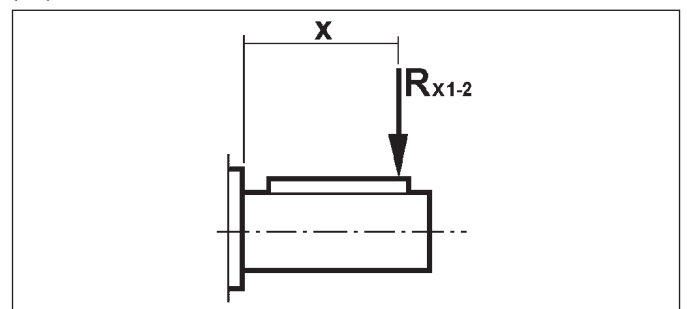



(B7)

	Costanti del riduttore / Load location factors Getriebekonstanten / Constantes du réducteur				Costanti del riduttore / Load location factors Getriebekonstanten / Constantes du réducteur		
	Albero lento / Output shaft Abtriebswelle / Arbre lent				R <sub>n2</sub> max [N]	Albero lento / Output shaft Abtriebswelle / Arbre lent	
	a	b	c			a	b
<b>S 10</b>	61	46	200	<b>VF 44</b>	71	51	2500
<b>S 20</b>	73.5	53.5	270	<b>VF 49</b>	99	69	3450
<b>S 30</b>	91.5	66.5	380	<b>W 63</b>	132	102	5000
<b>S 40</b>	126.5	96.5	600	<b>W 75</b>	139	109	6200
<b>S 50</b>	153.5	113.5	680	<b>W 86</b>	149	119	7000
<b>C 11</b>	46	26	450	<b>W 110</b>	173	136	8000
<b>C 21</b>	53	28	550	<b>VF 130</b>	182	142	13800
<b>C 31</b>	60.5	30.5	750	<b>VF 150</b>	198	155	16000
<b>C 35</b>	69.5	34.5	800	<b>VF 185</b>	220	170	19500
<b>C 41</b>	69.5	34.5	850	<b>VF 210</b>	268	203	34500
<b>C 51</b>	76.5	36.5	900	<b>VF 250</b>	334	252	52000
<b>C 61</b>	95.5	45.5	1000				
<b>C 70</b>	114	54	1200				
<b>C 80</b>	131	61	1500				
<b>C 90</b>	161	76	2000				
<b>C 100</b>	163.5	58.5	2500				

	Costanti del variatore / Load location factors Verstellgetriebekonstanten / Constantes du variateur		
	Albero lento / Output shaft Abtriebswelle / Arbre lent		
	a	b	c
<b>V 0.25</b>	59	48	240
<b>V 0.5</b>	63	48	240
<b>V 1</b>	75	55	285
<b>V 2</b>	86	61	335
<b>V 3</b>	122	92	550
<b>V 5.5</b>	122	92	550
<b>V 10</b>	154	114	700

### 8.1 - Carichi radiali sull'albero lento R<sub>n2</sub>

I valori nominali dei carichi radiali riferiti alla mezzzeria della sporgenza dell'albero lento sono indicati nelle tabelle di selezione dei motovariariduttori; essi sono calcolati rispettivamente in base alla coppia trasmessa M<sub>2</sub> e nelle condizioni più sfavorevoli come orientamento del carico e come senso di rotazione. Se i valori ammissibili risultassero inferiori a quelli desiderati, vi preghiamo di consultare il nostro servizio tecnico indicando l'esatta direzione del carico e il senso di rotazione dell'albero.

### 8.1 - Radial loads on output shaft R<sub>n2</sub>

*Rated values of radial loads referred to the mid-point of the output shaft extension are shown in the motovariator-gearbox unit selection charts. They are calculated based on transmitted torque M<sub>2</sub> and assuming the most unfavourable conditions in terms of both load angle and direction of rotation of the shaft. If permitted values are below actual values, please consult our technical service reporting exact load orientation and shaft rotation direction.*

### 8.1 - Radialkräfte auf die Abtriebswelle R<sub>n2</sub>

Die Nennwerte der Radialkräfte, die sich auf die Mitte des Wellenendes der Abtriebswelle beziehen, werden in den Auswahltabellen für die Verstellgetriebemotoren angegeben. Diese Werte werden jeweils unter Zugrundelegung des übertragenden Drehmoments M<sub>2</sub> und unter den ungünstigsten Bedingungen, im Hinblick auf die Kraftausrichtung und die Drehrichtung, entsprechend berechnet. Wenn die zulässigen Werte unter den verlangten Werten liegen, bitte unseren Technischen Kundendienst zu Rate ziehen, wobei die exakte Kraftrichtung und die Drehrichtung der Welle anzugeben ist.

### 8.1 - Charges radiales sur l'arbre lent R<sub>n2</sub>

*Les valeurs nominales des charges radiales, référées au milieu de la longueur disponible de l'arbre lent, sont indiquées aux tableaux de sélection des motovariaréducteurs: elles sont calculées respectivement sur la base du couple transmis M<sub>2</sub> et dans les conditions les plus défavorables d'orientation de la charge et du sens de rotation. Si les valeurs admissibles se révélaient inférieures à celles désirées, nous vous prions de consulter notre service technique en indiquant la direction exacte de la charge et le sens de rotation de l'arbre.*

### 9.0 - CARICHI ASSIALI A<sub>n2</sub>

I carichi assiali massimi ammissibili si possono calcolare come segue:

### 9.0 - THRUST LOADS A<sub>n2</sub>

*Maximum permitted thrust loads can be calculated as follows:*

$$A_{n2} = R_{n2} \cdot 0.2$$

### 9.0 - CHARGES AXIALES A<sub>n2</sub>

*Les charges axiales maximum admissibles peuvent se calculer comme suit :*

(13)

Anche in questo caso, in presenza di carichi assiali superiori a quelli ammissibili consultare il nostro servizio tecnico.

*In this case too, if thrust loads exceed permitted value, consult our technical service.*

Auch in diesem Fall bei höheren Axialkräften unseren Technischen Kundendienst zu Rate ziehen.

*Dans ce cas également, en présence de charges axiales supérieures à celles admissibles, consulter notre service technique.*



## 10.0 - LUBRIFICAZIONE RIDUTTORI

Un sistema misto bagno d'olio-sbattimento garantisce di regola la lubrificazione dei riduttori.

Per alcune posizioni di montaggio, generalmente caratterizzate da uno dei due assi verticali, opportune precauzioni vengono adottate al fine di garantire una adeguata lubrificazione anche agli organi più sfavoriti.

In alcune grandezze di riduttore il particolare lubrificante adottato, cosiddetto "long life" non richiede alcuna sostituzione per tutto l'arco di vita del riduttore stesso il quale pertanto viene fornito privo dei tappi di carico, scarico e livello.

Il primo riempimento viene effettuato da tutti gli stabilimenti Bonfiglioli esclusivamente con lubrificanti sintetici di marca **SHELL**.

Funzionamenti a temperature ambiente  $t_a$  comprese fra  $-15^\circ\text{C}$  e  $+50^\circ\text{C}$  sono in questo caso ammessi, tenendo presente che l'avviamento a temperature estremamente basse dovrà essere seguito da una fase di riscaldamento a carico molto ridotto. Per temperature inferiori a  $-15^\circ\text{C}$  consigliamo di contattare il ns. Servizio Tecnico.

Riduttori delle taglie superiori sono invece forniti "a secco" e sarà pertanto cura dell'utilizzatore riempirli di lubrificante prima della messa in opera. A questo scopo tali riduttori sono provvisti di tappi di carico, scarico e livello disposti in funzione della posizione di montaggio specificata in fase di ordinativo (illustrata nella specifica sezione di catalogo).

A garanzia di un funzionamento ottimale Bonfiglioli consiglia di eseguire il primo ed i successivi riempimenti ricorrendo sempre alle elevate prestazioni dei lubrificanti **SHELL**.

Confezioni da 4 l di **SHELL OMALA S4 WE 320** sono disponibili e possono essere ordinate presso la rete di vendita Bonfiglioli.

La tabella (B8) che segue costituisce il riferimento per la scelta della giusta viscosità in rapporto al tipo di riduttore.

## 10.0 - GEARBOX LUBRICATION

*Lubrication of gear units is usually provided through a combination of oil immersion and oil-splash patterns.*

*For some mounting positions, typically those featuring a vertical shaft, provisions are made to guarantee lubrication of even the least favourably located drive components.*

*Smallest gear units are filled in at the factory with a "long life" polyglycol-based lubricant, virtually maintenance-free and thus not requiring oil changes all throughout the operating life of the gearbox. In such a case gear units do not feature oil fill, level and drain plugs.*

*Original filling is provided by all Bonfiglioli assembly facilities exclusively with synthetic-base **SHELL** oil.*

*Under these conditions operation at ambient temperatures  $t_a$  in the range of  $-15^\circ\text{C}$  to  $+50^\circ\text{C}$  is allowed, bearing in mind that at start-up under extremely low temperature progressive loading may be recommended. Should the unit operate at temperatures well below  $-15^\circ\text{C}$  please contact Bonfiglioli's Technical Service for specific directions.*

*Larger size units are instead supplied dry and it will be the customer care to fill them with lubricant prior to putting them into operation. Consequently such units feature oil plugs properly located according to the particular mounting position specified at the ordering stage (coding shown in the specific catalogue section).*

*For a long lasting and trouble-free operation Bonfiglioli recommends that the first fill as well as following replacements are only made using **SHELL** lubricants.*

*4 l cans of **SHELL OMALA S4 WE 320** are available and can be sourced through Bonfiglioli Riduttori's sales network.*

*For determination of optimal oil specs for gear units originally supplied dry chart (B8) here under is the reference table for selection of the appropriate oil viscosity depending on gearbox type.*

## 10.0 - SCHMIERUNG DES GETRIEBES

Normalerweise sorgt ein kombiniertes System aus Ölbad-Ölumlauflauf für die Gewährleistung der Schmierung der Getriebe.

In einigen Montagepositionen, die im Allgemeinen von einer der beiden senkrechten Achsen gegeben wird, werden, um auch an den ungünstig liegenden Organen eine geeignete Schmierung zu gewährleisten entsprechende Vorsichtsmaßnahmen getroffen.

Bei einigen Getriebegrößen muß das verwendete Schmiermittel, das sogenannte "Long-Life"-Schmiermittel, während der gesamten Lebensdauer des Getriebes nicht mehr gewechselt werden. Aus diesem Grund werden sie auch ohne jeglichen Einfüll- sowie Ablassverschluß und ohne Pegelanzeige geliefert.

Die Füllung erfolgt direkt in den Bonfiglioli-Werken, dabei werden ausschließlich nur synthetische Schmiermittel der Marke **SHELL** verwendet.

In diesem Fall ist der Getriebeinsatz unter Umgebungstemperaturen  $t_a$  zwischen  $-15^\circ\text{C}$  und  $+50^\circ\text{C}$  zulässig. Hierbei ist jedoch zu berücksichtigen, daß einem Anlaß bei extrem niedrigen Temperaturen eine Aufwärmphase unter besonders geringen Belastungen folgen muß. Bei Temperaturen unter  $-15^\circ\text{C}$  empfehlen wir, sich mit unserem Technischen Kundendienst abzustimmen.

Die größeren Getriebe werden "trocken" geliefert, d.h. der Anwender muß vor der Inbetriebnahme das entsprechende Schmiermittel zugeben.

Zu diesem Zweck sind diese Getriebe mit Einfüll- sowie Ablasschrauben und mit einer Pegelanzeige ausgestattet, die der, bei der Auftragsgebung angegebenen Montageposition (im entsprechenden Abschnitt des Katalogs angegeben) entsprechend angeordnet sind.

Um den optimalen Betrieb gewährleisten zu können, empfiehlt die Bonfiglioli sowohl die Erstbefüllung als auch die nachfolgenden Füllungen mit den stark belastungsfähigen Schmiermitteln der **SHELL** vorzunehmen.

Die 4-Liter-Behälter des "**OMALA S4 WE 320**" können bei den Verkaufsstellen der Bonfiglioli angefordert werden.

Die nachstehende Tabelle (B8) gibt Bezugswerte für die Auswahl der richtigen Viskositäten im Verhältnis zum Getriebetyp.

## 10.0 - LUBRIFICATION DES REDUCTEURS

Normalement, un système mixte bain d'huile-barbotage garantit la lubrification des réducteurs.

Pour certaines positions de montage, généralement caractérisées par un des deux axes verticaux, des précautions opportunes sont adoptées afin de garantir une lubrification adéquate, même des organes les plus mal placés.

Sur certaines tailles de réducteur, le lubrifiant particulier adopté, de type "long life", ne nécessite aucun remplacement au cours de la durée de vie du réducteur, par conséquent, ce dernier est fourni sans bouchon de remplissage, de vidange et de niveau.

Le premier remplissage est effectué par tous les établissements Bonfiglioli, exclusivement avec des lubrifiants synthétiques de marque **SHELL**.

Dans ce cas, des fonctionnements à des températures ambiantes  $t_a$  comprises entre  $-15^\circ\text{C}$  et  $+50^\circ\text{C}$  sont admis, sans oublier cependant qu'un démarrage à des températures extrêmement faibles doit être suivi d'une phase de réchauffement à charge très réduite. En cas de températures inférieures à  $-15^\circ\text{C}$ , il est conseillé de contacter notre service technique.

Au contraire, les réducteurs de tailles supérieures sont fournis "à sec", par conséquent, l'utilisateur doit se charger de les remplir avec du lubrifiant avant leur mise en service.

Dans ce but, ces réducteurs sont équipés de bouchon de remplissage, de vidange et de contrôle du niveau situés en fonction de la position de montage spécifiée au moment de la commande (voir chapitre spécifique dans le catalogue).

Afin de garantir un fonctionnement optimal, nous conseillons d'effectuer le premier remplissage, ainsi que les suivants, en utilisant toujours des lubrifiants **SHELL**, dont les performances sont élevées.

Des bidons de 4 l de **SHELL OMALA S4 WE 320** sont disponibles et peuvent être commandés dans les points du réseau de vente Bonfiglioli.

Le tableau (B8) suivant constitue une référence concernant le choix de la viscosité correcte en fonction du type de réducteur.



(B8)

Lubrificante di fornitura originale Bonfiglioli Riduttori / <i>Original Bonfiglioli's lubricant supply</i> Schmiermittel der Orginalfüllung – Bonfiglioli Riduttori/ <i>Lubrifiants de fourniture originale Bonfiglioli Riduttori</i>	
Riduttori ad ingranaggi elicoidali / <i>Helical and bevel helical gear unit</i> Stirnradgetriebe und Kegelradgetriebe / <i>Réducteurs à engrenages hélicoïdaux</i>	<b>SHELL OMALA S4 WE 320</b>
Riduttori a vite senza fine / <i>Worm gear units</i> Schneckengetriebe / <i>Réducteurs à vis sans fin</i>	<b>SHELL OMALA S4 WE 320</b>
Riduttori a vite s/fine con limitatore di coppia / <i>Worm gear units c/w torque limiter</i> Schneckengetriebe mit Drehmomentenbegrenzer / <i>Réducteurs à vis sans fin avec limiteur de couple</i>	<b>SHELL OMALA S4 WE 460</b>
Variatori di velocità / <i>Speed variators</i> Verstelltriebemotoren / <i>Motovariateurs</i>	<b>SHELL SPIRAX S4 ATF HDX (V 0.25...V 0.5)</b> <b>SHELL SPIRAX S2 ATF AX (V 1...V 10)</b>

Qualora il lubrificante sintetico, preferibile per le superiori prestazioni, non sia disponibile localmente è consentito, **solo per i riduttori ad ingranaggi elicoidali e non per i riduttori a vite senza fine**, l'uso di lubrificante a base minerale. In questo caso suggeriamo l'uso di **SHELL OMALA S2 G 220**.

*Should the synthetic lubricant option, preferred performance wise, not be available locally it is allowed, for helical and bevel helical units only, not for worm units, the use of a mineral-base oil. In this case SHELL OMALA S2 G 220 must be considered as the preferred option.*

Sollte das bei höheren Leistungsausbringungen empfohlene synthetische Schmiermittel vor Ort nicht verfügbar sein, kann, **nur für die Stirnradgetriebe, Kegelradgetriebe und auf keinen Fall für die Schneckengetriebe**, auch ein Schmiermittel auf Mineralbasis verwendet werden. In diesem Fall empfehlen wir den Einsatz von **SHELL OMALA S2 G 220**.

*Si le lubrifiant synthétique, préférable pour ses performances supérieures, n'est pas disponible sur place, il est possible uniquement en ce que concerne les réducteurs à engrenages hélicoïdaux et non les réducteurs à vis sans fin, d'utiliser un lubrifiant à base minérale. Dans ce cas, nous conseillons d'utiliser SHELL OMALA S2 G 220.*

Bonfiglioli infine raccomanda che, qualora il lubrificante venga scelto al di fuori del tipo SHELL consigliato, questo sia di composizione equivalente in merito alla natura sintetica e alla viscosità, inoltre sia dotato degli opportuni additivi con funzione antischiuma.

*Bonfiglioli finally recommends that should the oil type be selected outside the recommended SHELL range the same is at least of equivalent composition as to the synthetic base and viscosity index besides including the appropriate anti-foam additives.*

Die Bonfiglioli weist letztendlich darauf hin, daß falls man ein von den empfohlenen SHELL-Typen abweichendes Schmiermittel wählen sollte, daß dieses in bezug auf seine synthetische Herkunft und Viskosität gleichwertig zusammengesetzt und darüber hinaus über geeignete Schaumstoffschutzstoffe verfügen sollte.

*Enfin, en cas de choix autre que le type SHELL conseillé, nous vous recommandons de choisir un lubrifiant équivalent, tant du point de vue de la nature synthétique que de la viscosité, de plus, sa composition doit comprendre des additifs anti-mousse appropriés.*

## 11.0 - MANUTENZIONE

I riduttori e variatori forniti con lubrificazione permanente non necessitano di alcuna manutenzione.

Per gli altri si consiglia di effettuare una prima sostituzione del lubrificante dopo circa 300 ore di funzionamento provvedendo ad un accurato lavaggio interno del gruppo con adeguati detergenti.

Evitare di miscelare olii a base minerale con olii sintetici.

Controllare periodicamente il livello del lubrificante effettuando la sostituzione indicativamente agli intervalli riportati nella tabella (B9).

## 11.0 - MAINTENANCE

*Life lubricated gearboxes do not require any maintenance.*

*For other types of gearboxes, the first oil change must take place after about 300 hours of operation, carefully flushing the internal parts of the unit using suitable detergents.*

*Do not mix mineral oils with synthetic oils.*

*Check oil level regularly and change oil at the intervals shown in the table (B9).*

## 11.0 - WARTUNG

Die mit Dauerschmierung gelieferten Getriebe bedürfen keiner Wartung.

Bei den übrigen Getrieben wird ein erster Ölwechsel nach ca. 300 Betriebsstunden empfohlen, wobei das Innere der Gruppe sorgfältig mit einem geeigneten Reinigungsmittel zu waschen ist.

Mineralöle nicht mit Syntheseölen mischen.

Den Ölstand regelmäßig kontrollieren. Die Ölwechsel in den in der Tabelle (B9) angegebenen Fristen durchführen.

## 11.0 - ENTRETIEN

*Les réducteurs fournis avec lubrification permanente n'ont besoin d'aucun entretien.*

*Pour les autres, nous conseillons d'effectuer une première vidange du lubrifiant après les 300 premières heures de fonctionnement en réalisant un lavage soigné à l'intérieur du groupe avec des produits détergents appropriés.*

*Éviter de mélanger les huiles à base minérale avec des huiles synthétiques.*

*Contrôler périodiquement le niveau du lubrifiant en effectuant les vidanges conformément aux intervalles indiqués dans le tableau (B9).*

(B9)

Temperatura olio / <i>Oil temperature</i> Öltemperatur / <i>Température huile</i>	Intervallo di lubrificazione / <i>Oil change interval</i> Schmierfrist / <i>Intervalle de lubrification</i>	
	[h]	
[°C]	olio minerale / <i>mineral oil</i> Mineralöl / <i>huile minérale</i>	olio sintetico / <i>synthetic oil</i> Syntheseöl / <i>huile synthétique</i>
< 65	8000	25000
65 - 80	4000	15000
80 - 95	2000	12500



## 12.0 - SCELTA

Per selezionare correttamente un motovariatore, è necessario disporre di alcuni dati che abbiamo sintetizzato nella tabella (B10). In particolare, essa potrà essere compilata ed inviata in copia al ns. Servizio Tecnico che provvederà alla ricerca della motorizzazione più idonea alla applicazione indicata.

## 12.0 - SELECTION

*Some fundamental data are necessary to assist the correct selection of a motor variator. The table below (B10) briefly sums up this information. To simplify matters, fill in the table and send a copy to our Technical Service which will select the most suitable drive unit for your application requirements.*

## 12.0 - ANTRIEBSAUSWAHL

Um einen Verstellmotor in korrekter Weise auswählen zu können, muß man über einige grundlegende Daten verfügen, die wir Ihnen in der folgenden Tabelle (B10) zusammengefaßt haben. Eine Kopie dieser vom Kunden ausgefüllten Tabelle kann an unseren Technischen Kundendienst geschickt werden, der dann die für die gewünschte Anwendung geeignete Auslegung wählt.

## 12.0 - SELECTION

*Pour sélectionner correctement un motovariateur, il faut disposer de certaines données fondamentales que nous avons résumées dans le tableau (B10). En particulier, ce dernier pourra être rempli et retourné à notre service technique qui recherchera la motorisation la plus appropriée à l'application indiquée.*

(B10)

Tipo di applicazione <i>Type of application</i> Anwendung <i>Type d'application</i>		.....	
P <sub>r2</sub> Potenza in uscita a n <sub>2</sub> max <i>Output power at n<sub>2</sub> max</i> Abtriebsleistung bei n <sub>2</sub> max <i>Puissance en sortie à n<sub>2</sub> maxi</i>	..... kW	A <sub>c2</sub> Carico assiale su albero in uscita (+/-)(***) <i>Thrust load on output shaft (+/-)(***)</i> Axialkraft auf Abtriebswelle (+/-)(***) <i>Charge axiale sur arbre de sortie (+/-)(***)</i>	..... N
P <sub>r2</sub> ' Potenza in uscita a n <sub>2</sub> min <i>Output power at n<sub>2</sub> min</i> Abtriebsleistung bei n <sub>2</sub> min <i>Puissance en sortie à n<sub>2</sub> mini</i>	..... kW	J <sub>c</sub> Momento d'inerzia del carico <i>Moment of inertia of the load</i> Trägheitsmoment der Last <i>Moment d'inertie de la charge</i>	..... Kgm <sup>2</sup>
M <sub>r2</sub> Momento torcente in uscita a n <sub>2</sub> max <i>Output torque at n<sub>2</sub> max</i> Abtriebsdrehmoment bei n <sub>2</sub> max <i>Moment de torsion en sortie à n<sub>2</sub> maxi</i>	..... Nm	t <sub>a</sub> Temperatura ambiente <i>Ambient temperature</i> Umgebungstemperatur <i>Température ambiante</i>	..... C°
n <sub>2</sub> Velocità di rotazione in uscita max <i>Max.output speed</i> Abtriebsdrehzahl max <i>Vitesse de rotation maxi en sortie</i>	..... min <sup>-1</sup>	Altitudine sul livello del mare <i>Altitude above sea level</i> Höhe ü.d.M. <i>Altitude au-dessus du niveau de la mer</i>	..... m
n <sub>2</sub> ' Velocità di rotazione in uscita min <i>Min.output speed</i> Abtriebsdrehzahl min <i>Vitesse de rotation mini en sortie</i>	..... min <sup>-1</sup>	Tipo di servizio in accordo a CEI <i>Duty type to IEC norms</i> Relative Einschaltdauer gemäß CEI <i>Type de service selon CEI</i>	S...../.....%
n <sub>1</sub> Velocità di rotazione in entrata max <i>Max.input speed</i> Antriebsdrehzahl max <i>Vitesse de rotation maxi en entrée</i>	..... min <sup>-1</sup>	Z Frequenza di avviamento <i>Starting frequency</i> Schaltungshäufigkeit <i>Fréquence de démarrage</i>	..... 1/h
n <sub>1</sub> ' Velocità di rotazione in entrata min <i>Min.input speed</i> Antriebsdrehzahl min <i>Vitesse de rotation mini en entrée</i>	..... min <sup>-1</sup>	Tensione di alimentazione motore <i>Motor voltage</i> Nennspannung des Motors <i>Tension de alimentation moteur</i>	..... V
R <sub>c2</sub> Carico radiale su albero in uscita <i>Radial load on output shaft</i> Radialkraft auf Abtriebswelle <i>Charge radiale sur arbre de sortie</i>	..... N	Tensione di alimentazione freno <i>Brake voltage</i> Nennspannung der Bremse <i>Tension de alimentation frein</i>	..... V
x <sub>2</sub> Distanza di applicazione del carico (*) <i>Load application distance (*)</i> Abstand des Kraftangriffspunktes (*) <i>Distance d'application de la charge (*)</i>	..... mm	Frequenza <i>Frequency</i> Frequenz <i>Fréquence</i>	..... Hz
Orientamento del carico in uscita <i>Load orientation at output</i> Orientierung der Last am Abtrieb <i>Orientation de la charge en sortie</i>	..... 	M <sub>b</sub> Coppia frenante <i>Brake torque</i> Bremsmoment <i>Couple de freinage</i>	..... Nm
Senso di rotazione albero uscita (O-AO) (**) <i>Output shaft rotation direction (CW-CCW) (**)</i> Drehrichtung der Abtriebswelle (U-GU) (**) <i>Sens de rotation arbre sortie (H-AH) (**)</i>	.....	Grado di protezione motore <i>Motor protection degree</i> Schutzart des Motors <i>Degré de protection moteur</i>	IP.....
		Classe di isolamento <i>Insulation class</i> Isolierstoffklasse <i>Classe d'isolation</i>	.....

(\*) La distanza x<sub>2</sub> è quella compresa fra il punto di applicazione della forza e la battuta dell'albero (se non indicata, si considererà la forza agente sulla mezzeria della sporgenza dell'albero).

(\*\*) O = orario ; AO = antiorario  
 (\*\*\*) + = compressione  
 - = trazione

(\*) Distance x<sub>2</sub> is between force application point and shaft shoulder (if not indicated the force exerted on the mid-point of the shaft extension will be considered).

(\*\*) CW = clockwise;  
 CCW = anticlockwise  
 (\*\*\*) + = compression  
 - = traction

(\*) Der Abstand x<sub>2</sub> ist der Abstand vom Kraftangriffspunkt zum Wellenansatz (wenn nicht anders angegeben, wird davon ausgegangen, daß die Kraft auf der Mitte des Wellenendes angreift).

(\*\*) U = Uhrzeigersinn;  
 GU = Gegenurzeigersinn  
 (\*\*\*) + = Druck  
 - = Zug

(\*) La distance x<sub>2</sub> est celle comprise entre le point d'application de la force et l'épaulement de l'arbre (si non précisée l'on considèrera la force agissant au milieu de la saillie de l'arbre).

(\*\*) H = sens horaire;  
 AH = sens antihoraire  
 (\*\*\*) + = compression  
 - = traction



### Utilizzo del motovariatore.

La particolarità del variatore meccanico è quella di essere utilizzato fino al limite di coppia consentito senza provocare lo slittamento del cinematismo che lo compone; tale slittamento risulta estremamente dannoso per la durata di vita del variatore. Essendo un cinematismo che trasmette potenze variabili e ricevendo in entrata una potenza costante, è ovvio che ai regimi inferiori la potenza trasmessa è sempre inferiore alla potenza installata in entrata.

Solamente al massimo del numero di giri in uscita del motovariatore è quantificabile l'entità dello sforzo sopportato dal variatore in quanto si può controllare l'assorbimento del motore elettrico.

Qualora questo valore superi il valore riportato sulla targhetta del motore elettrico si può affermare che il motovariatore è sottodimensionato. Questa verifica non si può eseguire quando il variatore non è al massimo dei giri perchè il motore non è impegnato in tutta la sua potenza. Qualora l'assorbimento risulti pari o inferiore a quello indicato sulla targhetta del motore, si può dire che la scelta del motovariatore è corretta.

**E' necessario evidenziare inoltre che il numero di avviamenti massimo consentito senza provocare conseguenze sulla durata del variatore, non deve superare gli 8 - 10 al minuto.**

### Use of the speed variator.

The distinctive feature of mechanical variators lies in their ability to operate up to the limit of permitted torque while avoiding slippage of the drive mechanism that would otherwise dramatically reduce variator life. Since the drive mechanism transmits variable power and is applied constant power at the input end, obviously transmitted power will always be lower than installed input power in the low rpm range.

The amount of stress applied to variator, i.e. can only be measured with the motovariator delivering maximum output speed by measuring the current drawn by the motor.

If measured consumption is higher than rated consumption reported on motor plate, one may safely conclude that the motovariator does not meet application requirements. Note that this verification can only be performed when the variator is running at peak rpm, i.e. the motor is operating with full power.

When current drawn is equal to or lower than motor rated value, it means that motovariator size has been selected properly.

**Note that the maximum number of starts allowed to preserve variator life is 8-10 starts per minute.**

### Einsatz der Getriebemotoren.

Die Besonderheit der mechanischen Verstellgetriebe liegt darin, daß sie bis zur Drehmomentengrenze verwendet werden können, ohne daß es dabei zu einer Schlüpfung des entsprechenden Getriebes kommt. Ein solches Schlüpfen wäre im Hinblick auf die Lebensdauer des Verstellgetriebes extrem schädlich. Da es sich um ein Getriebe handelt, das veränderbare Leistungen überträgt und im Antrieb eine konstante Leistung zugeführt bekommt, ist es selbstverständlich, daß in den unteren Drehzahlbereichen die übertragene Leistung immer unter der am Antrieb vorhandenen Leistung liegt.

Nur bei einer maximalen Drehzahl am Abtrieb des Verstellgetriebemotors kann das Ausmaß der auf das Verstellgetriebe einwirkenden Last bemessen werden, da man in diesem Fall die Aufnahme des Elektromotors kontrollieren kann. Sollte dieser Wert den auf dem Schild des Elektromotors angegebenen Wert überschreiten, bedeutet dies, daß der Verstellgetriebemotor unterdimensioniert ist. Die Kontrolle kann nur erfolgen, wenn sich das Verstellgetriebe im maximalen Drehzahlbereich befindet, da andernfalls der Motor nicht über seinen gesamten Leistungsbereich genutzt werden kann. Sollte die Aufnahme als gleich oder niedriger als die Angaben auf dem Schild resultieren, kann man davon ausgehen, daß man das richtige Verstellgetriebe ausgewählt hat.

**Es muß jedoch berücksichtigt werden, daß um die Lebensdauer des Verstellgetriebes nicht zu beeinträchtigen, die max. Zulässige Einschaltungen 8 - 10 pro Minuten nicht überschreiten darf.**

### Utilisation du motovariateur.

La particularité du variateur mécanique est d'être utilisé jusqu'à la limite de couple permise sans provoquer le glissement du cinematisme qui le compose; en effet, ce glissement est extrêmement nuisible pour la durée de vie du variateur. Etant donné que c'est le cinematisme qui transmet des puissances variables tout en recevant une puissance constante en entrée, il est évident qu'à des régimes inférieurs, la puissance transmise est toujours inférieure à la puissance installée en entrée.

L'entité de l'effort supporté par le variateur est quantifiable uniquement au nombre de tours maximum en sortie dans la mesure où il est alors possible de contrôler l'absorption du moteur électrique.

Si cette valeur dépasse la valeur indiquée sur la plaquette du moteur électrique, nous pouvons déduire que le motovariateur est sous dimensionné. Il est impossible d'effectuer cette vérification lorsque le variateur n'est pas au maximum de tours car toute la puissance du moteur n'est pas engagée.

Si l'absorption est égale ou inférieure à celle indiquée sur la plaquette du moteur, nous pouvons déduire que le choix du motovariateur est correct.

**De plus, il est nécessaire de vérifier que le nombre de démarrages maximum autorisé afin d'éviter des conséquences au niveau de la durée du variateur ne dépasse pas 8-10 démarrages par minute.**

### 12.1 Scelta dei motovariariduttori

- a) Determinare il fattore di servizio  $f_s$  in funzione del tipo di carico (fattore K), del numero di inserzioni/ora  $Z_r$  e del numero di ore di funzionamento.
- b) Dalla coppia  $M_{r2}$ , conoscendo  $n_2$  e il rendimento dinamico  $\eta_D$ , ricavare la potenza in entrata

### 12.1 Selection of motovariators

- a) Determine service factor  $f_s$  according to type of load (factor K), number of starts per hour  $Z_r$  and hours of operation.
- b) Providing torque  $M_{r2}$ , speed  $n_2$  and dynamic efficiency  $\eta_D$  are known, you can obtain input:

### 12.1 Wahl der Verstellgetriebemotoren

- a) Den Betriebsfaktor  $f_s$  in Abhängigkeit von der Belastungsart (Faktor K), den Schaltungen / Stunde  $Z_r$  und den Betriebsstunden bestimmen.
- b) Aus dem Drehmoment  $M_{r2}$  mit Hilfe der bekannten Werte für  $n_2$  und dem dynamischen Wirkungsgrad  $\eta_D$  die Antriebsleistung ableiten

### 12.1 Sélection des motovariaréducteurs

- a) Déterminer le facteur de service  $f_s$  en fonction du type de charge (facteur K), du nombre d'insertions/heure  $Z_r$  et du nombre d'heures de fonctionnement.
- b) A partir du couple  $M_{r2}$ , en connaissant  $n_2$  et le rendement dynamique  $\eta_D$ , calculer la puissance en entrée

$$P_{r1} = \frac{M_{r2} \cdot n_{2max}}{9550 \cdot \eta_D} \text{ [kW]} \quad (14)$$

Il valore di  $\eta_D$  per le varie serie di riduttori e variatori è indicato nella tabella (B11):

Value  $\eta_D$  for the different types of gearbox and variators is indicated in table (B11) below:

Der Wert für  $\eta_D$  für die verschiedenen Getriebeserien und Verstellgetriebeserien ist in Tabelle (B11) angegeben:

La valeur de  $\eta_D$ , pour les différentes séries de réducteurs et variateurs, est indiquée dans le tableau (B11):

(B11)

Serie / Series Serie / Série		N° stadi / Reductions / Anz. Stufen / Nombre d'étages de réduction		
		1	2	3
V	$\eta$	0.85 ( $n_2$ ) - 0.75 ( $n_2'$ )		
S		0.98	—	—
C		—	0.95	0.93
R		0.98	—	—



(B12)

		$n_1 = 1000 \text{ min}^{-1}$											$n_1' = 190 \text{ min}^{-1}$												
VF 44	i	7	10	14	20	28	35	46	60	70	100	—	—	7	10	14	20	28	35	46	60	70	100	—	—
	$\eta_{DR}$	85	82	78	74	67	64	59	54	51	43	—	—	83	80	80	72	64	60	55	50	47	39	—	—
VF 49	i	7	10	14	18	24	28	36	45	60	70	80	100	7	10	14	18	24	28	36	45	60	70	80	100
	$\eta_{DR}$	85	82	78	75	71	67	63	59	53	50	47	42	83	80	75	72	68	63	59	55	49	46	43	38
W 63	i	7	10	12	15	19	24	30	38	45	60	80	100	7	10	12	15	19	24	30	38	45	64	80	100
	$\eta_{DR}$	86	83	81	79	77	74	69	65	62	55	51	45	84	81	79	76	73	70	64	61	58	51	46	41
W 75	i	7	10	15	20	25	30	40	50	60	80	100	—	7	10	15	20	25	30	40	50	60	80	100	—
	$\eta_{DR}$	88	86	83	80	77	74	68	63	60	54	50	—	86	84	80	77	73	69	63	58	55	49	44	—
W 86	i	7	10	15	20	23	30	40	46	56	64	80	100	7	10	15	20	23	30	40	46	56	64	80	100
	$\eta_{DR}$	87	85	81	80	79	72	70	68	65	62	58	54	85	82	78	77	75	67	66	63	60	58	53	49
W 110	i	7	10	15	20	23	30	40	46	56	64	80	100	7	10	15	20	23	30	40	46	56	64	80	100
	$\eta_{DR}$	88	86	83	82	81	74	73	71	68	65	61	57	86	84	80	79	77	70	68	66	63	60	56	51
VF 130	i	7	10	15	20	23	30	40	46	56	64	80	100	7	10	15	20	23	30	40	46	56	64	80	100
	$\eta_{DR}$	88	87	84	82	81	77	73	73	70	68	64	59	86	84	81	79	77	72	68	68	65	62	58	54
VF 150	i	7	10	15	20	23	30	40	46	56	64	80	100	7	10	15	20	23	30	40	46	56	64	80	100
	$\eta_{DR}$	89	87	85	83	82	77	74	74	71	69	65	61	87	85	83	80	78	73	69	69	66	63	59	55
VF 185	i	7	10	15	20	30	40	50	60	80	100	—	—	7	10	15	20	30	40	50	60	80	100	—	—
	$\eta_{DR}$	89	88	86	84	81	76	73	71	66	62	—	—	88	86	84	81	77	71	68	66	60	56	—	—
VF 210	i	7	10	15	20	30	40	50	60	80	100	—	—	7	10	15	20	30	40	50	60	80	100	—	—
	$\eta_{DR}$	89	88	86	83	80	75	72	70	65	61	—	—	88	87	84	81	77	71	68	65	60	56	—	—
VF 250	i	7	10	15	20	30	40	50	60	80	100	—	—	7	10	15	20	30	40	50	60	80	100	—	—
	$\eta_{DR}$	90	89	87	85	81	76	73	72	67	63	—	—	88	87	85	82	79	72	68	68	62	58	—	—

**N.B.**  
Nel motovariariduttore, il rendimento complessivo  $\eta_D$  è dato dal prodotto del rendimento del variatore  $\eta_{DV}$  per il rendimento del riduttore  $\eta_{DR}$  ad esso collegato.

**NOTE:**  
On motovariators, total efficiency  $\eta_D$  results from the variator efficiency  $\eta_{DV}$  multiplied by the efficiency  $\eta_{DR}$  of the gearbox connected to it.

**MERKE:**  
Bei einem Verstellgetriebemotor wird der gesamte Wirkungsgrad  $\eta_D$  vom Wirkungsgradprodukt des Drehzahlwandlers  $\eta_{DV}$  für den Wirkungsgrad des mit diesen verbundenen Getriebes  $\eta_{DR}$  gegeben.

**N.B.**  
Dans un motovariariduttore, le rendement total  $\eta_D$  est donné par le produit du rendement du variateur  $\eta_{DV}$  multiplié par le rendement du réducteur  $\eta_{DR}$  y relié.

$$\eta_D = \eta_{DV} \cdot \eta_{DR}$$

(15)

Nei riduttori ad ingranaggi il rendimento dipende dal numero di stadi mentre la velocità ha scarsa influenza. Al contrario, nei vite senza fine è necessario considerare una notevole variabilità dei valori del rendimento  $\eta_{DR}$  in base al rapporto di riduzione  $i$  ed alla velocità in entrata  $n_1$  ( $n_1'$ ) come illustrato nella tabella (B12).

The efficiency of gearboxes is normally determined by the number of stages, while it is hardly affected by speed. Conversely, on worm gearboxes the efficiency  $\eta_{DR}$  varies notably depending on reduction ratio  $i$  and input speed  $n_1$  ( $n_1'$ ) as shown in table (B12).

Bei den Zahnradgetrieben hängt der Wirkungsgrad von der Anzahl der Stufen ab, während die Drehzahl hier nur geringen Einfluß hat. Im Gegensatz dazu, ist es bei den Schneckengetrieben erforderlich, eine erhebliche Schwankung der Wirkungsgradwerte  $\eta_{DR}$  in Bezug auf das Untersetzungsverhältnis  $i$  und der Antriebsdrehzahl  $n_1$  ( $n_1'$ ), wie in der Tabelle (B12) dargestellt, zu berücksichtigen.

Dans les réducteurs à engrenages le rendement dépend du nombre d'étages, la vitesse par contre a peu d'incidence. Au contraire, dans les modèles à vis sans fin il est nécessaire de considérer une remarquable variabilité des valeurs de rendement  $\eta_{DR}$  sur la base du rapport de réduction  $i$  et de la vitesse en entrée  $n_1$  ( $n_1'$ ), comme indiqué au tableau (B12).

c) Ricerchare fra le tabelle dei dati tecnici motovariariduttori quella corrispondente ad una potenza

c) Consult the selection charts and find the table corresponding to power

c) Unter den Tabellen mit den Technischen Daten der Verstellgetriebemotoren die Tabelle auswählen, die folgender Leistung entspricht:

c) Rechercher parmi les tableaux des caractéristiques techniques des motovariariduteurs celui correspondant à une puissance

$$P_1 \geq P_{r1}$$

(16)

Se non diversamente indicato, la potenza  $P_n$  dei motori riportata a catalogo si riferisce al servizio continuo S1. Per i motori utilizzati in condizioni diverse da S1, sarà necessario identificare il tipo servizio previsto con riferimento alle Norme CEI 2-3/IEC 34-1. In particolare, per i servizi da S2 a S8 e per le grandezze motore uguali o inferiori a 132, è possibile ottenere una maggiorazione della potenza rispetto a quella prevista per il servizio continuo, pertanto la condizione da soddisfare sarà:

Unless otherwise specified, power  $P_n$  of motors indicated in the catalogue refers to continuous duty S1. For motors used in conditions other than S1, the type of duty required by reference to CEI 2-3/IEC 34-1 Standards must be mentioned. For duties from S2 to S8 in particular and for motor frame 132 or smaller, extra power can be obtained with respect to continuous duty power, consequently the following condition must be satisfied:

Wenn nicht anders angegeben, bezieht sich die im Katalog angegebene Leistung  $P_n$  der Motoren auf Dauerbetrieb S1. Bei Motoren, die unter anderen Bedingungen als S1 eingesetzt werden, muß die vorgesehene Betriebsart unter Bezug auf die CEI-Normen 2-3/IEC 34-1 bestimmt werden. Insbesondere kann man für die Betriebsarten S2 bis S8 (und für Motorbaugrößen gleich oder niedriger als 132) eine Überdimensionierung der Leistung relativ zu der für den Dauerbetrieb vorgesehenen Leistung erhalten; die zu erfüllende Bedingung ist dann:

Sauf indication contraire la puissance  $P_n$  des moteurs indiquée dans le catalogue se réfère à un service continu S1. Pour les moteurs utilisés dans des conditions différentes du service S1, il sera nécessaire d'identifier le type de service prévu en se référant aux normes CEI 2-3/IEC 34-1. En particulier, pour les services de type S2 à S8 ou pour les tailles de moteurs égales ou supérieures à 132 il est possible d'obtenir une majoration de la puissance par rapport à celle prévue pour le service continu. Par conséquent, la condition à satisfaire sera :

$$P_1 \geq \frac{P_{r1}}{f_m}$$

(17)





Il fattore di maggiorazione  $f_m$  è ricavabile dalla tabella (B13).

The adjusting factor  $f_m$  can be obtained from table (B13).

Der Überdimensionierungsfaktor  $f_m$  kann der Tabelle (B13) entnommen werden.

Le facteur de majoration  $f_m$  peut être obtenu en consultant le tableau (B13).

(B13)

	SERVIZIO / DUTY / BETRIEB / SERVICE						
	S2			S3*			S4 - S8
	Durata del ciclo / Cycle duration [min] Zyklusdauer / Durée du cycle [min]			Rapporto di intermittenza / Cyclic duration factor (I) Relative Einschaltdauer / Rapport d'intermittence (I)			Interpellarci Please contact us Rückfrage Nous contacter
	10	30	60	25%	40%	60%	
$f_m$	1.35	1.15	1.05	1.25	1.15	1.1	

\* La durata del ciclo dovrà comunque essere uguale o inferiore a 10 minuti; se superiore interpellare il nostro Servizio Tecnico.

\* Cycle duration, in any event, must be 10 minutes or less. If it is longer, please contact our Technical Service.

\* Die Zyklusdauer muß in jedem Fall kleiner oder gleich 10 min sein; wenn sie darüber liegt, unseren Technischen Kundendienst zu Rate ziehen.

\* La durée du cycle devra être égale ou inférieure à 10 minutes. Si supérieure, contactez notre Service Technique.

Rapporto di intermittenza

Cyclic duration factor

Relative Einschaltdauer

Rapport d'intermittence

$$I = \frac{t}{t_f + t_r} \cdot 100 \quad (18)$$

$t_f$  = tempo di funzionamento a carico costante  
 $t_r$  = tempo di riposo

$t_f$  = operating time at constant load  
 $t_r$  = rest time

$t_f$  = Betriebszeit mit konstanter Belastung  
 $t_r$  = Aussetzzeit

$t_f$  = temps de fonctionnement à charge constante  
 $t_r$  = temps de repos

Scegliere poi, in base alla velocità di uscita  $n_2$  ( $n_2'$ ), il motovariariduttore con un fattore di sicurezza S calcolato maggiore o uguale al fattore di servizio  $f_s$ .  
Le tabelle dei dati tecnici dei motovariariduttori si riferiscono a velocità di motori a 2, 4 e 6 poli (50Hz).

Next, according to output speed  $n_2$  ( $n_2'$ ), select a motor-variator-gearbox units having a calculated safety factor S higher than or equal to service factor  $f_s$ .  
The motor-variator-gearbox units selection charts refer to 2, 4 and 6 pole motors (50Hz).

Dann auf Grundlage der Abtriebsdrehzahl  $n_2$  ( $n_2'$ ) den Verstellgetriebemotor mit einem Sicherheitsfaktor S wählen, der größer oder gleich dem Betriebsfaktor  $f_s$  ist. Die Tabellen mit den Technischen Daten der Verstellgetriebemotoren beziehen sich auf die Drehzahlen von Motoren mit 2, 4 und 6 Polen (50Hz).

Choisir ensuite, suivant la vitesse en sortie  $n_2$  ( $n_2'$ ), le motovariaréducteur avec un facteur de sécurité calculé S supérieur ou égal au facteur de service  $f_s$ .  
Les tableaux des caractéristiques techniques des motovariaréducteurs se réfèrent aux vitesses de moteurs à 2, 4 et 6 pôles (50 Hz).

### 13.0 - VERIFICHE

Effettuata la corretta selezione delle motorizzazioni, si consiglia di procedere alle seguenti verifiche:

#### a) Potenza termica

Assicurarsi che la potenza termica del riduttore abbia un valore uguale o maggiore alla potenza richiesta dall'applicazione secondo la relazione (3), in caso contrario selezionare un riduttore di grandezza superiore oppure provvedere ad applicare un sistema di raffreddamento forzato.

#### b) Coppia massima

Generalmente la coppia massima (intesa come punta di carico istantaneo) applicabile al riduttore non deve superare il 200% della coppia nominale  $M_{n2}$ ; verificare pertanto che tale limite non venga superato adottando, se necessario, opportuni dispositivi per la limitazione della coppia.

### 13.0 - VERIFICATION

After selecting the drive units, it is recommended to check the following:

#### a) Thermal capacity

Check that thermal capacity of the gear unit is equal to or larger than the power requirement calculated for the application, as specified by equation (3). If this condition is not respected, select a larger gearbox or apply a forced cooling system.

#### b) Maximum torque

The maximum torque (intended as instantaneous peak load) applicable to the gearbox must not, in general, exceed 200% of rated torque  $M_{n2}$ . Therefore, check that this limit is not exceeded, using suitable torque limiting devices, if necessary.

### 13.0 - PRÜFUNGEN

Nach Wahl des Getriebemotors folgende Prüfungen ausführen:

#### a) Thermische Grenzleistung

Sicherstellen, daß die Wärme-grenzleistung ist, größer oder gleich der verlangten Leistung ist, die von der Anwendung nach Gleichung (3) verlangt wird. Andernfalls ein größer dimensioniertes Getriebe wählen bzw. ein Zwangskühlsystem vorsehen.

#### b) Max. Drehmoment

Im allgemeinen darf das max. Drehmoment (verstanden als momentane Lastspitze), das auf das Getriebe aufgebracht werden kann, 200 % des Nenndrehmoments  $M_{n2}$  nicht überschreiten. Sicherstellen, daß dieser Grenzwert nicht überschritten wird, und nötigenfalls die entsprechenden Vorrichtungen zur Begrenzung des Drehmoments vorsehen.

### 13.0 - VERIFICATIONS

Après avoir effectué une sélection correcte des motorisations, nous conseillons de procéder aux vérifications suivantes :

#### a) Puissance thermique

S'assurer que la puissance thermique du réducteur ait une valeur supérieure ou égale à la puissance requise par l'application selon l'équation (3). Dans le cas contraire, sélectionner un réducteur de taille supérieure ou bien prévoir un système de refroidissement forcé.

#### b) Couple maximum

Généralement, le couple maximum (à considérer comme une pointe de charge instantanée) applicable au réducteur ne doit pas dépasser les 200% du couple nominal  $M_{n2}$ . Vérifier par conséquent que cette limite ne soit pas dépassée en adoptant, si nécessaire, des dispositifs adaptés pour limiter le couple.



### c) Carichi radiali

Verificare che i carichi radiali agenti sugli alberi di uscita rientrino nei valori di catalogo ammessi. Se superiori, aumentare la grandezza del riduttore oppure modificare la supportazione del carico. Ricordiamo che tutti i valori indicati nel catalogo si riferiscono a carichi agenti sulla mezzeria della sporgenza dell'albero in esame per cui, in fase di verifica, è indispensabile tenere conto di questa condizione provvedendo, se necessario, a determinare con le apposite formule il carico ammissibile alla distanza  $x$  desiderata. A tale proposito si rimanda ai paragrafi relativi ai carichi radiali.

### d) Carichi assiali

Anche gli eventuali carichi assiali dovranno essere confrontati con i valori ammissibili riportati nel catalogo. Se si è in presenza di carichi assiali molto elevati o combinati con carichi radiali, si consiglia di interpellare il ns. servizio tecnico.

### e) Motori elettrici

Se il motore elettrico è montato dall'utente è necessario accertarsi che la flangia e l'albero siano lavorati con tolleranze che corrispondano a una classe di qualità precisa. Per quanto concerne i motori da accoppiare a variatori con differenziale è indispensabile (per prevenire fuoriuscite di lubrificante) che siano dotati di un anello di tenuta sull'albero e che la flangia sia stagna. Prima di effettuare l'installazione verificare che il senso di rotazione del riduttore/variante corrisponda a quello previsto. Per servizi diversi da S1, con un numero rilevante di inserzioni/ora si dovrà tener conto di un fattore  $Z$  (determinabile con le indicazioni riportate nel capitolo dei motori) il quale definisce il numero max. di avviamenti specifico per l'applicazione in oggetto.

### c) Radial loads

*Check that radial loads applying on output shafts are within permitted catalogue values. If they are higher, use a larger gearbox or modify system bearing arrangement. Remember that all values mentioned in the catalogue refer to loads applying at mid-point of the shaft under consideration. Therefore, when checking, this condition must be borne in mind and, if necessary, determine permitted load at the required  $x$  distance by means of appropriate equations. In this connection, consult the headings on radial loads.*

### d) Thrust loads

*Thrust loads, if present, must also be compared to the permitted values indicated in the catalogue. In the event of extremely high thrust loads, or a combination of thrust and radial loads, contact our technical service department.*

### e) Electric motors

*If the electric motor is to be installed by the User, make sure that the machining tolerance of flange and shaft provides sufficient precision. When a motor is to be fitted to a variator with differential unit, it must be equipped with an oil seal on the shaft and equipped with a flange ensuring proper sealing to avoid lubricant leaks. Before installation, check that direction of rotation of reducer/variator is as specified. For duties other than S1 with considerable number of starts per hour, factor  $Z$  must be considered (it is ascertained by using the information in the motors section). Factor  $Z$  defines the maximum number of starts for the application under consideration.*

### c) Radialkräfte

Sicherstellen, daß die auf die Abtriebswellen wirkenden Radialkräfte innerhalb der zulässigen Katalogwerte liegen. Wenn sie höher sind, das Getriebe größer dimensionieren bzw. die Abstützung der Last verändern. Wir erinnern daran, daß alle im Katalog angegebenen Werte sich auf Kräfte beziehen, die auf die Mitte des Wellenendes wirken. Diese Tatsache muß bei der Prüfung unbedingt berücksichtigt werden und nötigenfalls muß mit Hilfe der geeigneten Formeln die zulässige Kraft beim gewünschten Abstand  $x$  bestimmt werden. Siehe hierzu die Erläuterungen zu den Radialkräften in diesem Katalog.

### d) Axialkräfte

Auch die eventuell vorhandenen Axialkräfte müssen mit den im Katalog angegebenen zulässigen Werten verglichen werden. Wenn sehr hohe Axialkräfte wirken oder Axialkräfte in Kombination mit Radialkräften, bitte unseren Technischen Kundendienst zu Rate ziehen.

### e) Elektromotoren

Wird der Elektromotor vom Kunden montiert, muß man sich darüber vergewissern, daß der Flansch und die Welle mit solchen Toleranzen gearbeitet wurden, die einer präzisen Qualitätsklasse angehören. Was die mittels Differential an die Verstellgetriebe zu passenden Motoren anbelangt, müssen diese unbedingt mit einem Dichtring an der Welle ausgestattet sein und der Flansch muß eine entsprechende Dichte gewährleisten (um einen Schmiermittelverlust vorzubeugen). Vor dem Einbau muß geprüft werden, ob die Umdrehungsrichtung des Getriebes/Verstellgetriebes der vorgesehenen entspricht. Bei anderen Betriebsarten als S1 mit einem hohen Wert für die Schaltungen/Stunde muß der Faktor  $Z$  berücksichtigt werden (er kann mit Hilfe der Angaben im Kapitel Motoren bestimmt werden), der die max. zulässige Anzahl von Schalten für eine bestimmte Anwendung definiert.

### c) Charges radiales

*Vérifier que les charges radiales agissant sur les arbres de sortie se situent dans les valeurs de catalogue admises. Si elles sont supérieures, choisir la taille du réducteur supérieure ou modifier la reprise de charge. Rappelons que toutes les valeurs indiquées dans le catalogue se réfèrent à des charges agissant au milieu de la longueur disponible de l'arbre contrôlé. Par conséquent, en phase de vérification, il est indispensable de prendre en considération cette condition en déterminant, si nécessaire, avec les formules appropriées, la charge admissible à la distance  $x$  désirée. Se rapporter à ce propos aux paragraphes relatifs aux charges radiales.*

### d) Charges axiales

*Les éventuelles charges axiales devront être comparées avec les valeurs admissibles indiquées dans le catalogue. Si l'on est en présence de charges axiales très élevées ou combinées avec des charges radiales, nous conseillons d'interpeller notre service technique.*

### e) Moteur électriques

*Si le moteur électrique est monté par l'utilisateur, il est nécessaire de vérifier que la bride et l'arbre soient usinés avec des tolérances correspondant à une classe de qualité précise. En ce qui concerne les moteurs à accoupler aux variateurs avec différentiel, il est indispensable (afin d'éviter les fuites de lubrifiant) qu'ils soient dotés d'une bague d'étanchéité sur l'arbre et que la bride soit étanche. Avant de procéder à l'installation, vérifier que le sens de rotation du réducteur/variante correspond au sens prévu. Pour les services différents de S1, avec un nombre important d'insertions/heure, il faudra prendre en considération un facteur  $Z$  (déterminé à l'aide des informations reportées dans le chapitre des moteurs) qui définit le nombre maximum de démarrages spécifique pour l'application concernée.*

## 14.0 - INSTALLAZIONE

È molto importante, per l'installazione del riduttore/variante, attenersi alle seguenti norme:

a) Assicurarsi che il fissaggio del riduttore/variante, sia stabile onde evitare qualsiasi vibrazione. Installare (se si prevedono urti, sovraccarichi prolungati o possibili bloc-

## 14.0 - INSTALLATION

*The following installation instructions for gearboxes/variators must be observed:*

a) *Make sure that the gearbox/variator is correctly secured to avoid vibrations. If shocks, overloading, or the possibility of locking are expected, install hydraulic cou-*

## 14.0 - INSTALLATION

Für die Installation des Getriebes/Verstellgetriebes ist es äußerst wichtig, daß folgende Normen beachtet werden:

a) Sicherstellen, daß die Befestigung des Getriebes/Verstellgetriebes stabil ist, damit keine Schwingungen entstehen. Wenn es voraussichtlich zu Stößen, länger-

## 14.0 - INSTALLATION

*Il est très important, pour l'installation du réducteur/variante, de se conformer aux règles suivantes :*

a) *S'assurer que la fixation du réducteur/variante soit stable afin d'éviter toute vibration. Installer (en cas de chocs, de surcharges prolongées ou de blocages) des*



caggi) giunti idraulici, frizioni, limitatori di coppia, ecc..

*plings, clutches, torque limiters, etc.*

dauernden Überlasten oder zu Blockierungen kommen kann, sind entsprechende Schutzelemente wie hydraulische Kupplungen, Kupplungen, Rutschkupplungen usw. zu installieren.

*coupleurs hydrauliques, des embrayages, des limiteurs de couple etc...*

- |   |   |   |  |
|---|---|---|--|
| <p>b) Durante la verniciatura si dovranno proteggere i piani lavorati e il bordo esterno degli anelli di tenuta per evitare che la vernice ne essichi la gomma, pregiudicando la tenuta del paraolio stesso.</p> <p>c) Gli organi che vanno calettati sugli alberi di uscita del riduttore devono essere lavorati con tolleranza ISO H7 per evitare accoppiamenti troppo bloccati che, in fase di montaggio potrebbero danneggiare irreparabilmente il riduttore stesso. Inoltre, per il montaggio e lo smontaggio di tali organi si consiglia l'uso di adeguati tiranti ed estrattori utilizzando il foro filettato posto in testa alle estremità degli alberi.</p> <p>d) Le superfici di contatto dovranno essere pulite e trattate con adeguati protettivi prima del montaggio, onde evitare l'ossidazione e il conseguente bloccaggio delle parti.</p> <p>e) L'accoppiamento all'albero di uscita cavo del riduttore (tolleranza G7/H7) viene normalmente eseguito con perni lavorati con tolleranza h6. Dove il tipo di applicazione lo richieda, si può prevedere un accoppiamento con una leggera interferenza (G7/H7 - j6).</p> <p>f) Prima della messa in funzione della macchina, accertarsi che la posizione del livello del lubrificante sia conforme alla posizione di montaggio del riduttore e che la viscosità sia adeguata al tipo del carico.</p> | <p>b) <i>Before paint coating the unit, the machined surfaces and the outside face of the oilseals must be masked to prevent paint drying out the rubber and jeopardising the sealing function.</i></p> <p>c) <i>Parts assembled on the gearbox output shafts must be machined to ISO H7 tolerance to prevent interference fits that could damage the gearbox itself. Further, to mount or demount such parts, employ suitable pullers or extraction devices using the tapped hole located at the top of the shaft extension.</i></p> <p>d) <i>Mating surfaces must be cleaned and treated with suitable protective products before assembling to avoid oxidation and, as a result, seizure of parts.</i></p> <p>e) <i>Coupling to the gearbox output hollow shaft (tolerance G7) is usually effected with shafts machined to h6 tolerance. If the type of application requires it, coupling with a slight interference fit (G7 - j6) is possible.</i></p> <p>f) <i>Before starting up the machine, make sure that oil level conforms to the gear unit mounting position, and that viscosity is suitable for the load involved.</i></p> | <p>b) Beim Lackieren die bearbeiteten Flächen und die Dichtungen schützen, damit der Anstrichstoff nicht dem Kunststoff angreift und somit die Dichtigkeit der Ölabdichtungen in Frage gestellt wird.</p> <p>c) Die Organe, die mit einer Keilverbindung auf der Abtriebswelle des Getriebes befestigt werden, müssen mit einer Toleranz ISO H7 gearbeitet sein, um allzu fest blockierte Verbindungen zu vermeiden, die eventuell zu einer irreparablen Beschädigung des Getriebes während des Einbaus führen könnten. Außerdem sind beim Einund Ausbau dieser Organe geeignete Zugschrauben und Abzieher zu verwenden, wobei die Gewindebohrung an den Köpfen der Wellen zu verwenden ist.</p> <p>d) Die Berührungsf lächen müssen sauber sein und vor der Montage mit einem geeigneten Schutzmittel behandelt werden, um Oxidierung und die daraus folgende Blockierung der Teile zu verhindern.</p> <p>e) Die Verbindung mit der Abtriebswelle des Getriebes (Toleranz G7) wird normalerweise mit Zapfen mit Toleranz h6 hergestellt. Wo die Anwendungsart dies verlangt, kann man die Verbindung mit einem leichten Übermaß ausführen (G7 - j6).</p> <p>f) Vor Inbetriebnahme der Maschine sicherstellen, daß die Anordnung der Füllstandschraube der Einbaulage angemessen ist, und die Viskosität des Schmiermittels der Belastungsart entspricht.</p> | <p>b) <i>En phase de peinture, il faudra protéger les plans usinés et le bord extérieur des bagues d'étanchéité pour éviter que la peinture ne dessèche le caoutchouc, ce qui risque de nuire à l'efficacité du joint.</i></p> <p>c) <i>Les organes qui sont calés sur les arbres de sortie du réducteur doivent être réalisés avec une tolérance ISO H7 pour éviter les accouplements trop serrés qui, en phase de montage, pourraient endommager irrémédiablement le réducteur. En outre, pour le montage et le démontage de ces organes, nous conseillons d'utiliser un outillage et des extracteurs appropriés en utilisant le trou taraudé situé en extrémité d'arbre.</i></p> <p>d) <i>Les surfaces de contact devront être propres et traitées avec des produits de protections appropriés avant le montage afin d'éviter l'oxydation et par suite le blocage des pièces.</i></p> <p>e) <i>L'accouplement à l'arbre de sortie creux du réducteur (tolérance G7) est habituellement réalisé avec des arbres exécutés à la tolérance h6. Lorsque le type d'application le demande, on peut prévoir un accouplement avec une légère interférence (G7 - j6).</i></p> <p>f) <i>Avant la mise en marche de la machine, s'assurer que la position du niveau du lubrifiant soit conforme à la position de montage du réducteur et que la viscosité soit appropriée au type de charge.</i></p> |
|---|---|---|--|

### 15.0 - STOCCAGGIO

Il corretto stoccaggio dei prodotti ricevuti richiede l'esecuzione delle seguenti attività:

- a) Escludere aree all'aperto, zone esposte alle intemperie o con eccessiva umidità.
- b) Interporre sempre tra il pavimento ed i prodotti, pianali lignei o di altra natura, atti ad impedire il diretto contatto col suolo.
- c) Per periodi di stoccaggio superiori ai 60 giorni, le superfici interessate agli accoppiamenti quali flange, alberi e giunti, devono essere protette con

### 15.0 - STORAGE

*Observe the following instructions to ensure correct storage of delivered products:*

- a) *Do not store outdoors, in areas exposed to weather or with excessive humidity.*
- b) *Always place boards in wood or other material between floor and products, to avoid direct contact with the floor.*
- c) *For storage periods of over 60 days, all machined surfaces such as flanges, shafts and couplings must be protected with a suitable an-*

### 15.0 - LAGERUNG

Die korrekte Lagerung der Antriebe erfordert folgende Vorkehrungen:

- a) Die Produkte nicht im Freien lagern und nicht in Räumen, die der Witterung ausgesetzt sind, oder eine hohe Feuchtigkeit aufweisen.
- b) Die Produkte nie direkt auf dem Boden, sondern auf Unterlagen aus Holz oder einem anderen Material lagern.
- c) Bei Lagerzeiten von mehr als 60 Tagen die Oberflächen für die Verbindung, wie Flansche, Wellen oder Kupplungen mit einem geeigneten

### 15.0 - STOCKAGE

*Un correct stockage des produits reçus nécessite de respecter les règles suivantes :*

- a) *Exclure les zones à ciel ouvert, les zones exposées aux intempéries ou avec humidité excessive.*
- b) *Interposer dans tous les cas entre le plancher et les produits des planches de bois ou des supports d'autre nature empêchant le contact direct avec le sol.*
- c) *Pour les périodes de stockage supérieures à 60 jours, les surfaces concernées par les liaisons telles que les brides, les arbres et les accou-*



idoneo prodotto antiossidante (Mobilarma 248 od equivalente).

*ti-oxidation product (Mobilarma 248 or equivalent product).*

Oxidations- schutzmittel behandeln (Mobilarma 248 oder ein äquivalentes Mittel).

*plements doivent être protégées avec un produit antioxydant spécial (Mobilarma 248 ou équivalent).*

- d) Per periodi di stoccaggio previsti superiori ai 6 mesi, i prodotti devono essere oggetto delle seguenti attività:  
d1)  
I prodotti forniti con lubrificazione permanente dovranno avere le parti lavorate esterne e quelle di accoppiamento ricoperte di grasso atto ad evitare ossidazioni.  
d2)  
I prodotti forniti privi di lubrificante, oltre alle attività descritte al punto d1), dovranno essere posizionati con il tappo di sfiato nella posizione più alta e riempiti di olio. I riduttori, prima del loro utilizzo, dovranno essere riempiti con la corretta quantità e tipo di lubrificante previsto.

- d) *The following measures must be taken in respect of products for which the expected storage period exceeds 6 months:*  
d1)  
*For life lubricated products, the external machined parts must be greased to prevent oxidation.*  
d2)  
*In addition to the measures at point d1), products supplied without oil must be positioned with the breather plug high up, and be filled with oil.*  
*Before using the gearboxes, restore the correct quantity of recommended oil.*

- d) Bei Lagerzeiten von mehr als 6 Monaten müssen folgende Vorkehrungen getroffen werden:  
d1)  
Bei den Produkten mit Dauerschmierung müssen die maschinell bearbeiteten Außenseiten und die Verbindungsflächen mit Fett vor Oxidation geschützt werden.  
d2)  
Die Produkte ohne Schmiermittel müssen wie unter Punkt d1) behandelt werden und außerdem mit nach oben gerichteter Entlüftungsschraube gelagert und mit Öl gefüllt werden. Die Getriebe müssen vor ihrer Verwendung mit der angegebenen Menge des vorgegebenen Schmiermittels gefüllt werden.

- d) *Pour les périodes de stockage prévues supérieures à 6 mois, les produits doivent être objet des contrôles suivants :*  
d1)  
*les produits fournis avec lubrification permanente devront avoir les parties externes usinées ainsi que celles de liaison recouvertes de graisse pour éviter les oxydations.*  
d2)  
*les produits fournis sans lubrifiant, outre les opérations décrites au point d1), devront être positionnés avec le bouchon d'évent dans la position la plus haute et remplis d'huile.*  
*Les réducteurs, avant d'être utilisés, devront être remplis avec la juste quantité et type de lubrifiant prévu.*

#### 16.0 - CONDIZIONI DI FORNITURA

I riduttori e i variatori vengono forniti come segue:

- a) già predisposti per essere installati nella posizione di montaggio come definito in fase di ordine;  
b) collaudati secondo specifiche interne;  
c) appositamente imballati;  
d) le superfici di accoppiamento non sono verniciate;  
e) provvisti di dadi e bulloni per montaggio motori per la versione IEC(dove previsto);  
f) tutti i riduttori/variatori sono forniti con protezioni in plastica sugli alberi;  
g) già provvisti di lubrificante (dove previsto);  
h) già verniciati (dove previsto);  
i) già provvisti di golfare di sollevamento (dove previsto).

#### 16.0 - SUPPLY CONDITIONS

*Units are supplied as follows:*

- a) *ready for installation in the mounting position specified when ordering;*  
b) *tested to manufacturer specifications;*  
c) *appropriately packed;*  
d) *mating machined surfaces are not paint coated;*  
e) *IEC-flanged units are supplied complete with bolts for fastening the motor;*  
f) *all gearboxes/variators are supplied with plastic protection on shafts;*  
g) *oil filled (if applicable);*  
h) *paint coated (where applicable);*  
i) *fitted with lifting hook (if applicable).*

#### 16.0 - LIEFERBEDINGUNGEN

Die Getriebe und Verstellgetriebe werden in folgendem Zustand geliefert:

- a) schon bereit für die Montage in der bei Bestellung festgelegten Einbaulage;  
b) nach werksinternen Spezifikationen geprüft;  
c) ordnungsgemäss verpackt;  
d) die Verbindungsflächen sind nicht lackiert;  
e) ausgestattet mit Schrauben und Muttern für die Montage der Motoren (Version mit Adapter für IEC-Motoren, falls vorgesehen);  
f) alle Getriebe/Verstellgetriebe werden mit Kunststoffschutz auf den Wellen geliefert;  
g) Schmiermittel (falls vorgesehen) bereits vorhanden;  
h) bereits lackiert (falls vorgesehen);  
i) mit Transportriem zum Anheben (falls vorgesehen).

#### 16.0 - CONDITIONS DE LIVRAISON

*Les réducteurs et les variateurs sont livrés comme suit :*

- a) *déjà prédisposés pour être installés dans la position de montage comme défini en phase de commande ;*  
b) *testés selon les spécifications internes ;*  
c) *emballés comme il se doit ;*  
d) *les surfaces de liaison ne sont pas peintes ;*  
e) *équipés d'écrous et de boulons pour le montage des moteurs normalisés pour la version CEI ;*  
f) *tous les réducteurs/variateurs sont fournis avec des embouts de protections en plastique sur les arbres ;*  
g) *déjà dotés de lubrifiant (quand cela est prévu) ;*  
h) *déjà peints (quand cela est prévu) ;*  
i) *déjà dotés d'un crochet de levage (quand cela est prévu).*

#### 17.0 - SPECIFICHE DELLA VERNICE

Le specifiche della vernice applicata sui riduttori e variatori (dove previsto) potranno essere richieste alle filiali o ai distributori che hanno fornito i gruppi.

#### 17.0 - PAINT SPECIFICATIONS

*Paint specifications for paint applied to gearboxes and variators (where appropriate) may be requested from the branches or dealers that supplied the units.*

#### 17.0 - ANGABEN ZU DEN ANSTRICHSTOFFE

Die Spezifikationen des Lackes, der auf den Getriebe und Verstellgetriebe (wo erforderlich) verwendet wurde, können bei den Filialen oder Verkaufsstellen, die die Gruppen geliefert haben, angefordert werden.

#### 17.0 - SPECIFICATIONS DE LA PEINTURE

*Les spécification de la peinture appliquée sur les réducteurs et les variateurs pourront, le cas échéant, être demandées aux filiales ou aux distributeurs ayant fourni les groupes.*

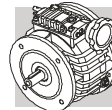

**18.0 - MOTOVARIATORI**  
***MOTOVARIATOR***  
**VERSTELLGETRIEBEMOTOREN**  
***MOTOVARIATEURS***

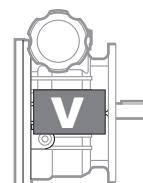

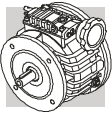

**18.1 - Caratteristiche costruttive**

**18.1 - Design characteristics**

**18.1 - Baumerkmale**

**18.1 - Caracteristiques de construction**

	<b>V 0.25</b>	<b>V 0.5</b>	<b>V 1</b>	<b>V 2</b>
<ul style="list-style-type: none"> <li>• Casse in ghisa ad alta resistenza (Alluminio per V 0.25)</li> <li>• Campo di variazione 1:5.5</li> <li>• Campo di variazione con differenziale <math>\infty</math></li> <li>• Ingombri contenuti</li> <li>• Affidabilità</li> <li>• Lunga durata</li> <li>• Assenza di manutenzione</li> <li>• Economicità</li> </ul>	<ul style="list-style-type: none"> <li>• <i>High-resistance cast-iron cases (Aluminium for V 0.25)</i></li> <li>• <i>Speed range 1:5.5</i></li> <li>• <i>Variation range defferential <math>\infty</math></i></li> <li>• <i>Compactness</i></li> <li>• <i>Reliability</i></li> <li>• <i>Extended life</i></li> <li>• <i>Maintenance-free</i></li> <li>• <i>Cost effectiveness</i></li> </ul>	<ul style="list-style-type: none"> <li>• Gehäuse aus hochwiderstandsfähigem Gußeisen (Aluminiumgehäuse für V 0.25)</li> <li>• Verstellbereich 1:5,5</li> <li>• Bei einer Ausführung mit Differential: Verstellbereich <math>\infty</math></li> <li>• kleine Abmasse</li> <li>• hohe Zuverlässigkeit</li> <li>• lange Lebensdauer</li> <li>• Wartungsfreiheit</li> <li>• Wirtschaftlichkeit</li> </ul>	<ul style="list-style-type: none"> <li>• <i>Carter en fonte à résistance élevée (Aluminium pour V 0.25)</i></li> <li>• <i>Plage de variation 1:5.5</i></li> <li>• <i>Plage de variation avec différentiel <math>\infty</math></i></li> <li>• <i>Encombrements limités</i></li> <li>• <i>Fiabilité</i></li> <li>• <i>Longévité</i></li> <li>• <i>Absence d'entretien Economie</i></li> </ul>	

I modelli V 0.25...V 2 sono disponibili in varie forme costruttive e possono essere abbinati direttamente ai riduttori della BONFIGLIOLI RIDUTTORI come raffigurato nella tabella (C01).

V 0.25...V 2 models are available in different configurations all matching with the gear units of BONFIGLIOLI RIDUTTORI. See chart (C01).

Die Verstellgetriebe der Serie V 0.25...V 2 sind in unterschiedlichen Bauformen erhältlich und können mit verschiedenen anderen Getriebeserien kombiniert werden; siehe dazu Tabelle (C01).

Tous les variateurs de la série V 0.25...V 2 peuvent être accouplés aux réducteurs de BONFIGLIOLI RIDUTTORI ainsi qu'il est illustré au tableau (C01).

(C01)

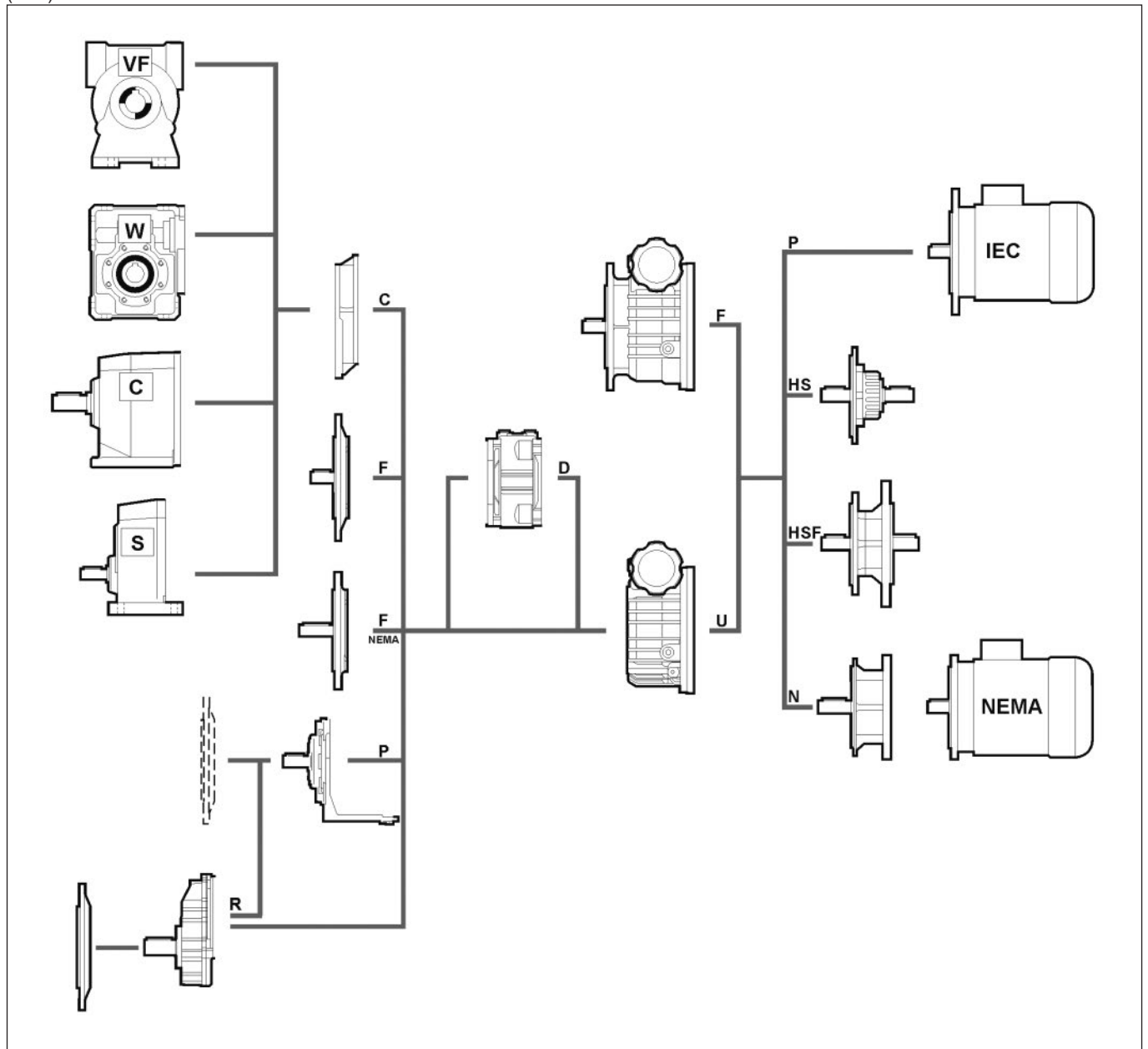

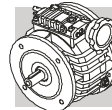

**V 3      V 5.5      V 10**

- Casse in ghisa ad alta resistenza
- Campo di variazione 1:5.5
  - Campo di variazione con differenziale  $\infty$
  - Ingombri contenuti
  - Affidabilità
  - Lunga durata
  - Assenza di manutenzione
  - Economicità

- High-resistance cast-iron cases*
- *Speed range 1:5.5*
  - *Variation range differential  $\infty$*
  - *Compactness*
  - *Reliability*
  - *Extended life*
  - *Maintenance-free*
  - *Cost effectiveness*

- Gehäuse aus hochwiderstandsfähigem Gußeisen
- Verstellbereich 1:5,5
  - Bei einer Ausführung mit Differential: Verstellbereich  $\infty$
  - kleine Abmasse
  - hohe Zuverlässigkeit
  - lange Lebensdauer
  - Wartungsfreiheit
  - Wirtschaftlichkeit

- Carter en fonte à résistance élevée*
- *Plage de variation 1:5.5*
  - *Plage de variation avec différentiel  $\infty$*
  - *Encombrements limités*
  - *Fiabilité*
  - *Longévité*
  - *Absence d'entretien*
  - *Economie*

I modelli V 3...V 10 sono disponibili in varie forme costruttive e possono essere abbinati direttamente ai riduttori della BONFIGLIOLI RIDUTTORI come raffigurato nella tabella (C02).

*V 3...V 10 models are available in different configurations all matching with the gear units of BONFIGLIOLI RIDUTTORI. See chart (C02).*

Die Verstellgetriebe der Serie V 3...V 10 sind in unterschiedlichen Bauformen erhältlich und können mit verschiedenen anderen Getriebenserien kombiniert werden; siehe dazu Tabelle (C02).

*Tous les variateurs de la série V 3...V 10 peuvent être accouplés aux réducteurs de BONFIGLIOLI RIDUTTORI ainsi qu'il est illustré au tableau (C02).*

(C02)

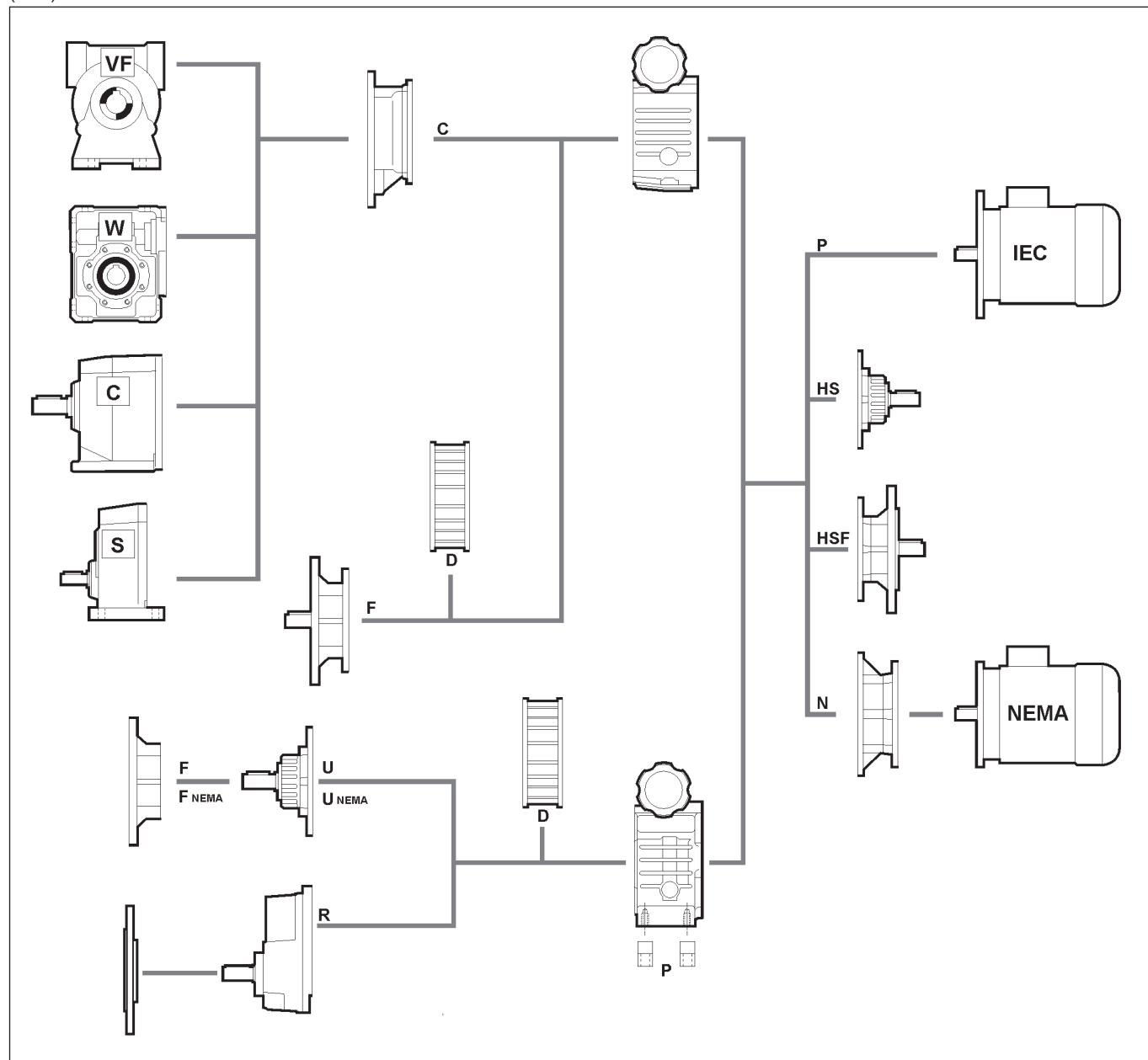

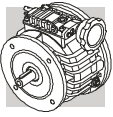

V\_

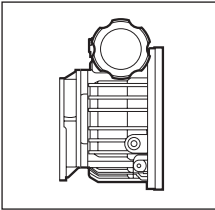

**C**  
V 0.25...V 10

La forma costruttiva C è prevista esclusivamente per il collegamento diretto ai riduttori serie S, C, VF, W.  
Version C is only available for direct connection to gearboxes of the series S, C, VF and W.  
Die Bauform C ist dabei ausschließlich für den direkten Anschluß an die Getriebe S, C, VF, W vorgesehen.  
La forme de construction C est uniquement prévue pour l'accouplement direct aux réducteurs S, C, VF, W.

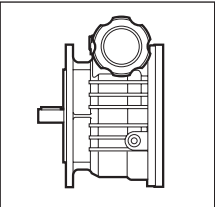

**F**  
V 0.25...V 10  
Con flangia integrale  
Flange mount  
Mit Flansch  
Avec bride

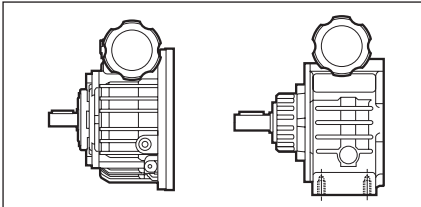

**U**  
V 0.25...V 2 (\*) V 3...V 10  
Con albero sporgente  
Solid output shaft  
Mit freier Welle im Ausgang  
Avec arbre sortant

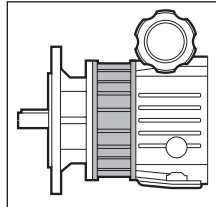

**F**  
VD 3...VD 10  
Differenziale e flangia  
Differential + mounting flange  
Differential und Flansch  
Différentiel et bride

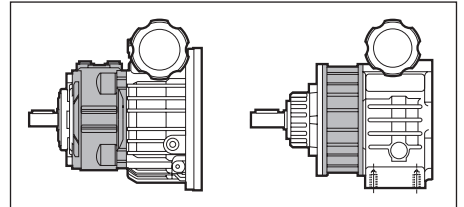

**U**  
VD 0.5...VD 2(\*) VD 3...VD 10  
Differenziale e albero sporgente  
Differential + solid output shaft  
Differential und freier Welle  
Différentiel et arbre sortant

(\*) La forma costruttiva U, per i variatori V 0.25...V 2, deve essere obbligatoriamente completata con uno dei fissaggi sotto indicati (F, P, ecc.).

(\*) For models V 0.25...V 2 the U version MUST mandatorily be completed with one of the fittings listed here under (F, P, etc.)

(\*) Die Bauform U, für die Verstellgetriebe V 0.25...V 2, muß verbindlich mit einer von den u.g. Befestigungen (F, P, usw) ergänzt werden.

(\*) La forme constructive U, pour les variateurs V 0.25... V 2, doit obligatoirement être complétée avec un des fixages sous indiqués (F, P, etc.).

Tipo di fissaggio per versione U

Fittings for U version

Montagemöglichkeit für die Bauform U

Type de fixation pour la forme de construction U

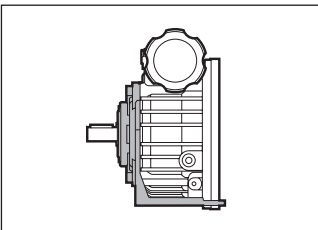

**P**  
V 0.25...V 10  
Con piedi riportati  
With bolt-on feet  
Mit Füßen  
Avec adjonction de pieds

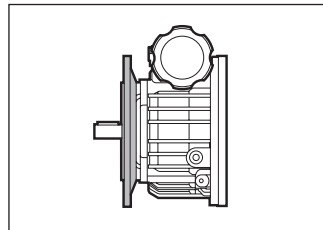

**F (IEC)**  
V 0.25...V 10  
Con flangia riportata  
With bolt-on flange  
Mit Flansch  
Avec adjonction d'une bride

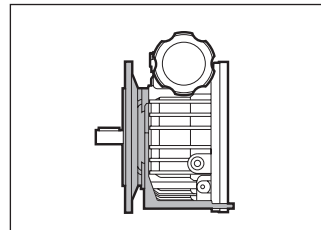

**PF (IEC)**  
V 0.25...V 2  
Con flangia e piedi riportati  
With bolt-on flange and feet  
Mit Flansch und Füßen  
Avec adjonction d'une bride et de pieds

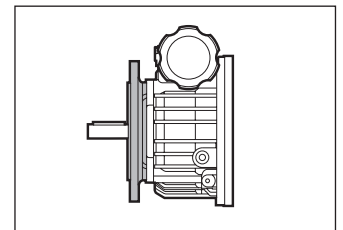

**F NEMA**  
V 0.25...V 10  
Con flangia riportata NEMA  
With bolt-on Nema flange  
Mit NEMA Flansch  
Avec adjonction d'une bride NEMA

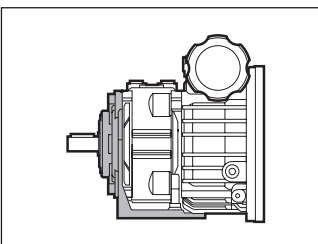

**P**  
VD 0.5...VD 10  
Esecuzione con differenziale e piedi riportati  
With bolt-on feet and differential  
Ausführung mit Differential und Füßen  
Réalisation avec différentiel et adjonction de pieds

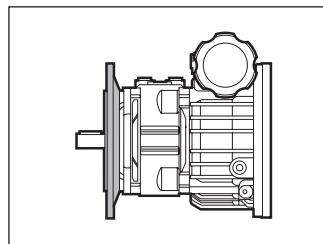

**F (IEC)**  
VD 0.5...VD 10  
Esecuzione con differenziale e flangia riportata  
With bolt-on flange and differential  
Ausführung mit Differential und Flansch  
Réalisation avec différentiel et adjonction d'une bride

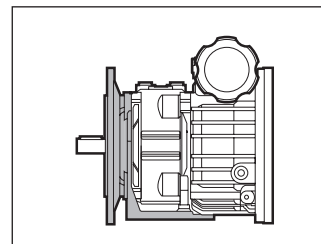

**PF (IEC)**  
VD 0.5...VD 10  
Esecuzione con differenziale, flangia e piedi riportati  
With bolt-on flange, feet and differential  
Ausführung mit Differential und Flansch und Füßen  
Réalisation avec différentiel et adjonction d'une bride et de pieds



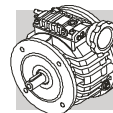

## VR\_

### VR\_B3B...

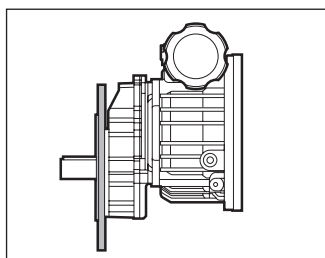

**F**  
VR 0.25...VR 10

Con flangia  
*Flanged*  
Mit Flansch  
*Avec bride*

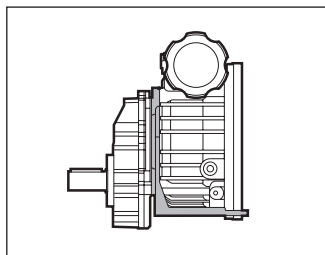

**P**  
VR 0.25...VR 10

Con piedi  
*Footed*  
Mit Füßen  
*Avec pieds*

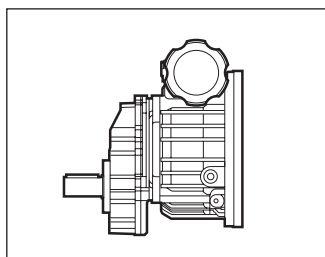

**U**  
VR 0.25...VR 2

Con cassa universale  
*Universal mount*  
Mit Universalgehäuse  
*Avec carter universel*

### VRD\_B3B...

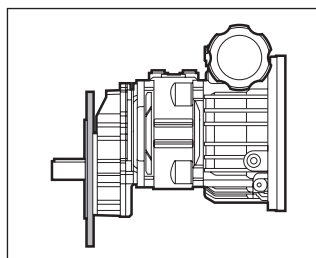

**F**  
VRD 0.5...VRD 10

Con differenziale e flangia  
*Flanged unit with differential*  
Mit Differential und Flansch  
*Avec différentiel et bride*

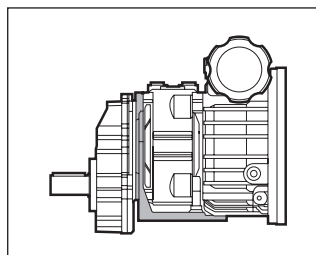

**P**  
VRD 0.5...VRD 10

Esecuzione con differenziale e piedi  
*Footed unit with differential*  
Ausführung mit Differential und Füßen  
*Réalisation avec différentiel et pieds*

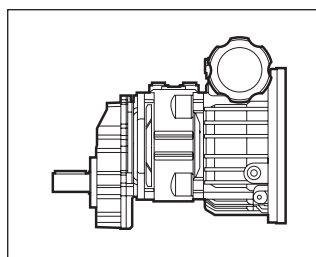

**U**  
VRD 0.5...VRD 2

Con differenziale e cassa universale  
*Universal mount with differential*  
Mit Differential und Universalgehäuse  
*Avec différentiel et carter universel*

### VR\_B3A...

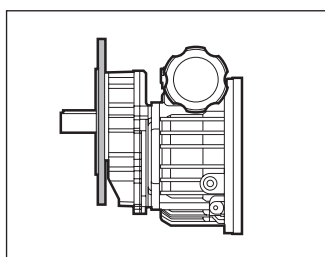

**F**  
VR 0.25...VR 10

Con flangia  
*Flanged*  
Mit Flansch  
*Avec bride*

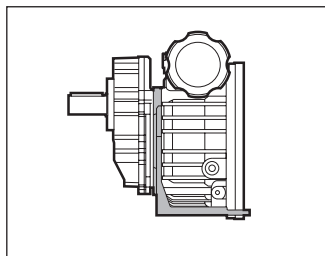

**P**  
VR 0.25...VR 10

Con piedi  
*Footed*  
Mit Füßen  
*Avec pieds*

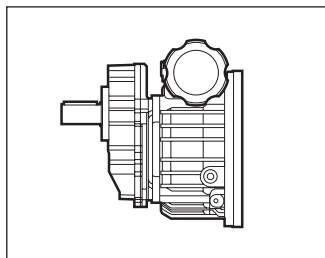

**U**  
VR 0.25...VR 2

Con cassa universale  
*Universal mount*  
Mit Universalgehäuse  
*Avec carter universel*

### VRD\_B3A...

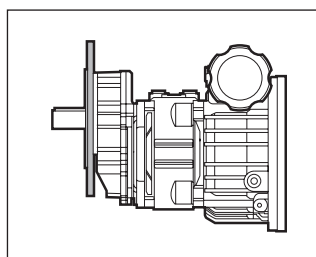

**F**  
VRD 0.5...VRD 10

Con differenziale e flangia  
*Flanged unit with differential*  
Mit Differential und Flansch  
*Avec différentiel et bride*

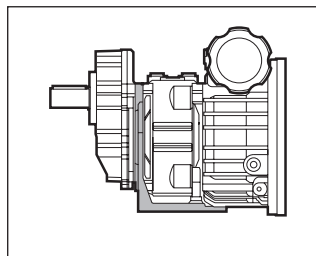

**P**  
VRD 0.5...VRD 10

Esecuzione con differenziale e piedi  
*Footed unit with differential*  
Ausführung mit Differential und Füßen  
*Réalisation avec différentiel et pieds*

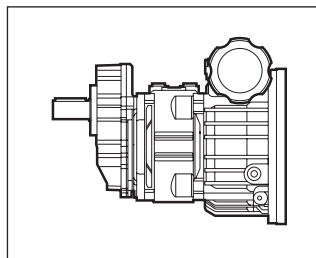

**U**  
VRD 0.5...VRD 2

Con differenziale e cassa universale  
*Universal mount with differential*  
Mit Differential und Universalgehäuse  
*Avec différentiel et carter universel*

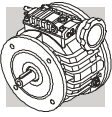

18.3 - Designazione

18.3 - Designation

18.3 - Bezeichnung

18.3 - Désignation

**V D 0.5 U F71 D14 P71 B3 A 1 PDN SCT ....**

OPZIONI / OPTIONS  
OPTIONEN / OPTIONS

TIPO DI COMANDO / REMOTE CONTROL TYPE  
VERSTELLEINRICHTUNG / TYPE DE COMMANDE  
**A, VG, VA, VAG, SCT (3Ø), TC (1Ø)**

SONDA RILEVATRICE / SPEED SENSOR  
MEßSONDE / SONDE DE DETECTION  
**PDN, PDNA, PDP**

POSIZIONE DISPOSITIVO DI COMANDO / SPEED KNOB POSITION  
EINBAULAGE DER VERSTELLEINRICHTUNG / POSITION COMMANDE  
**1 (default), 2 (V 3...V 10)**

POSIZIONE PIEDI RIPORTATI / BOLT-ON FEET POSITION  
EINBAULAGE DER FÜßEN / POSITION DE MONTAGE DE PIEDS  
(V 0.25...V 2)

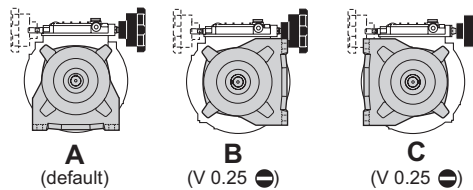

POSIZIONE DI MONTAGGIO / MOUNTING POSITION  
MOTOR BAUFORM / FORME DE CONSTRUCTION DU MOTEUR  
**B3 (default), B6, B7, B8, V5, V6**

39

CONFIGURAZIONE INGRESSO / INPUT CONFIGURATION  
BEZEICHNUNG DER ANTRIEBSSEITE / DESIGNATION ENTREE

- P (IEC)** - predisposizione IEC / *Provided with IEC motor adaptor*  
vorbereitet für den Anbau eines IEC-Motors / *prédisposé IEC*
- HS** - albero cilindrico / *solid input shaft* / freier Antriebswelle / *arbre rapide sortant*
- HSF** - albero cilindrico e flangia riportata / *solid input shaft and bolt-on flange*  
freier Antriebswelle und Flansch / *arbre rapide sortant et adjonction de bride*
- N (NEMA)** - predisposizione motore NEMA / *provided with Nema motor adaptor*  
vorbereitet für den Anschluß eines NEMA-Motors / *prédisposé moteur NEMA*

DIAMETRO ALBERO LENTO / OUTPUT SHAFT DIAMETRE  
ABTRIEBSWELLE DURCHMESSER / DIAMETRE ARBRE LENT

**D +** diametro in mm / *diameter in mm* / Durchmesser in mm / *diamètre en mm (11,14,...)*  
**IMP** albero in pollici / *inch series shaft* / Nema-Welle / *arbre NEMA*

TIPO DI FISSAGGIO (per gruppi tipo U) / OUTPUT CONFIGURATION (only for U version)  
MONTAGEMÖGLICHKEIT (ausschließlich für die Bauform U) / TIPE DE FIXATION (pour forme de construction U)

- F (IEC)** - flangia IEC riportata / *bolt-on IEC flange* / Flansch IEC / *adjonction de bride IEC*
- P** - piedi riportati / *bolt-on feet* / Füßen / *adjonction de pieds*
- PF (IEC)** - piedi + flangia IEC riportata / *feet and bolt-on IEC flange*  
Füßen und Flansch IEC / *adjonction de pieds et de bride IEC*
- F (NEMA)** - flangia NEMA / *NEMA flange mounted* / NEMA Flansch / *bride Nema*

FORMA COSTRUTTIVA / VERSION / BAUFORM / VERSION

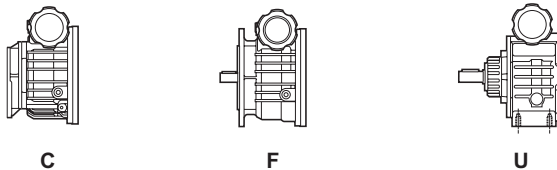

GRANDEZZA VARIATORE / VARIATOR SIZE / BAUGRÖSSE / TAILLE VARIATEUR  
**0.25, 0.5, 1, 2, 3, 5.5, 10**

DIFFERENZIALE / DIFFERENTIAL / DIFFERENTIAL / DIFFERENTIEL  
**D**

VARIATORE / VARIATOR TYPE / VERSTELLGETRIEBETYP / TYPE VARIATEUR  
**V**

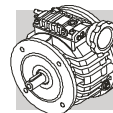

MOTORE / MOTOR  
MOTOR / MOTEUR

FRENO / BRAKE  
BREMSE / FREIN

**BN 71A 4 R 230/400-50 IP54 CLF B5 FD 3.5 R SB 220SA** .....

OPZIONI  
OPTIONS  
OPTIONEN  
OPTIONS

307

ALIMENTAZ. FRENO  
BRAKE SUPPLY  
BREMSVERSORGUN-  
GSSPANNUNG  
ALIMENTATION FREIN

320

TIPO ALIMENTATORE  
RECTIFIER TYPE  
GLEICHRICHTERTYP  
TYPE ALIMENTATEUR  
**NB, NBR, SB, SBR**

LEVA DI SBLOCCO FRENO  
BRAKE HAND RELEASE  
BREMSENTLÜFTUNGSHABEL  
LEVIER DE DEBLOCAGE FREIN  
**R, RM**

COPPIA FRENANTE / BRAKE TORQUE  
BREMSMOMENT / COUPLE FREIN

327  
331  
335

TIPO FRENO / BRAKE TYPE  
BRESENTYP / TYPE DE FREIN

**FD** (freno c.c./d.c. brake / Gleichstrombremse / frein c.c.)  
**FA, BA** (freno c.a./a.c. brake / Wechselstrombremse  
frein c.a.)

FORMA COSTRUTTIVA / MOTOR EXECUTION  
BAUFORM / FORME DE CONSTRUCTION  
**B5**

CLASSE ISOLAMENTO / INSULATION CLASS  
ISOLATIONSKLASSE / CLASSE ISOLATION  
**CL F** standard; **CL H** (option)

GRADO DI PROTEZIONE / PROTECTION CLASS  
SCHUTZKLASSE / DEGRE DE PROTECTION

**IP55** standard (IP54 autofr./brake motor / für Bremsmotoren / motor frein)

TENSIONE-FREQUENZA / VOLTAGE-FREQUENCY  
SPANNUNG-FREQUENZ / TENSION-FREQUENCE

291

FLANGIA E ALBERO RIDOTTI / REDUCED FLANGE AND SHAFT  
VERKLEINERTEM FLANSCH UND VERKLEINERTER WELLE / BRIDE ET ARBRE REDUITS

NUMERO DI POLI / NUMBER OF POLES / POLZAHL / N.bre POLES

**2, 4, 6**

GRANDEZZA MOTORE / MOTOR SIZE / MOTORBAUGRÖSSE / TAILLE MOTEUR

**63 - 132** ( motore IEC / IEC motor / IEC motoren / moteur CEI)

MOTORE / MOTOR TYPE / MOTORTYP / TYPE MOTEUR

**BN** = trifase IEC / IEC 3-phase / IEC-Motor (Dreiphasen) / 3 phase CEI

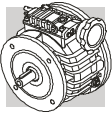

**VR D 0.5 F 6.3 P71 B3A A 1 PDN SCT .....**

OPZIONI / OPTIONS  
OPTIONEN / OPTIONS

TIPO DI COMANDO / REMOTE CONTROL TYPE  
VERSTELLEINRICHTUNG / TYPE DE COMMANDE  
**A, VG, VA, VAG, SCT (3Ø), TC (1Ø)**

SONDA RILEVATRICE / SPEED SENSOR  
MEßSONDE / SONDE DE DETECTION  
**PDN, PDNA, PDP**

POSIZIONE DISPOSITIVO DI COMANDO / SPEED KNOB POSITION  
EINBAULAGE DER VERSTELLEINRICHTUNG / POSITION COMMANDE  
**1 (default), 2 (V 3...V 10)**

POSIZIONE PIEDI RIPORTATI / BOLT-ON FEET POSITION  
EINBAULAGE DER FÜßEN / POSITION DE MONTAGE DE PIEDS  
(V 0.25...V 2)

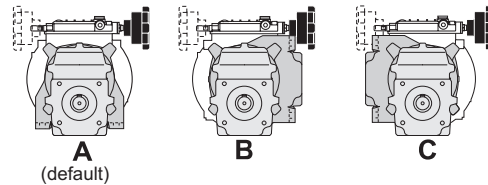

POSIZIONE DI MONTAGGIO / MOUNTING POSITION  
MOTOR BAUFORM / FORME DE CONSTRUCTION DU MOTEUR  
**B3A (default), B6A, B7A, B8A, V5A, V6A  
B3B, B6B, B7B, B8B, V5B, V6B**

39

CONFIGURAZIONE INGRESSO // INPUT CONFIGURATION  
BEZEICHNUNG DER ANTRIEBSSEITE / DESIGNATION ENTREE

- P (IEC)** - predisposizione IEC / Provided with IEC motor adaptor  
vorbereitet für den Anbau eines IEC-Motors / prédisposé IEC
- HS** - albero cilindrico / solid input shaft  
freier Antriebswelle / arbre rapide sortant
- HSF** - albero cilindrico e flangia riportata / solid input shaft and bolt-on flange  
freier Antriebswelle und Flansch / arbre rapide sortant et adjonction de bride
- N (NEMA)** - predisposizione motore NEMA / provided with NEMA motor adaptor  
vorbereitet für den Anschluß eines NEMA-Motors / prédisposé moteur NEMA

RAPPORTO DI RIDUZIONE / GEAR RATIO / ÜBERSETZUNG / RAPPORT DE REDUCTION

FORMA COSTRUTTIVA / VERSION / BAUFORM / VERSION

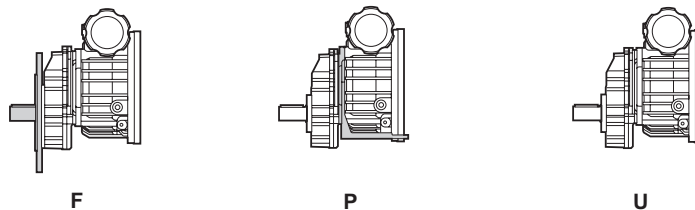

GRANDEZZA / FRAME SIZE / BAUGRÖSSE / TAILLE  
**0.25, 0.5, 1, 2, 3, 5.5, 10**

DIFFERENZIALE / DIFFERENTIAL / DIFFERENTIAL / DIFFERENTIEL  
**D**

SERIE / VARIATOR TYPE / VERSTELLGETRIEBETYP / SERIE VARIATEUR  
**VR**

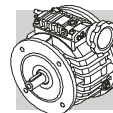

MOTORE / MOTOR  
MOTOR / MOTEUR

FRENO / BRAKE  
BREMSE / FREIN

**BN 71A 4 R 230/400-50 IP54 CLF B5 FD 3.5 R SB 220SA** .....

OPZIONI  
OPTIONS  
OPTIONEN  
OPTIONS

307

ALIMENTAZ. FRENO  
BRAKE SUPPLY  
BREMSVERSORGUN-  
GSSPANNUNG  
ALIMENTATION FREIN

320

TIPO ALIMENTATORE  
RECTIFIER TYPE  
GLEICHRICHTERTYP  
TYPE ALIMENTATEUR  
**NB, NBR, SB, SBR**

LEVA DI SBLOCCO FRENO  
BRAKE HAND RELEASE  
BREMSENTLÜFTUNGSHABEL  
LEVIER DE DEBLOCAGE FREIN  
**R, RM**

COPPIA FRENANTE / BRAKE TORQUE  
BREMSMOMENT / COUPLE FREIN

327  
331  
335

TIPO FRENO / BRAKE TYPE  
BRESENTYP / TYPE DE FREIN

**FD** (freno c.c./d.c. brake / Gleichstrombremse / frein c.c.)  
**FA, BA** (freno c.a./a.c. brake / Wechselstrombremse  
frein c.a.)

FORMA COSTRUTTIVA / MOTOR EXECUTION  
BAUFORM / FORME DE CONSTRUCTION  
**B5**

CLASSE ISOLAMENTO / INSULATION CLASS  
ISOLATIONSKLASSE / CLASSE ISOLATION  
**CL F** standard; **CL H** (option)

GRADO DI PROTEZIONE / PROTECTION CLASS  
SCHUTZKLASSE / DEGRE DE PROTECTION

**IP55** standard (IP54 autofr./brake motor / für Bremsmotoren / motor frein)

TENSIONE-FREQUENZA / VOLTAGE-FREQUENCY  
SPANNUNG-FREQUENZ / TENSION-FREQUENCE

291

FLANGIA E ALBERO RIDOTTI / REDUCED FLANGE AND SHAFT  
VERKLEINERTEM FLANSCH UND VERKLEINERTER WELLE / BRIDE ET ARBRE REDUITS

NUMERO DI POLI / NUMBER OF POLES / POLZAHL / N.bre POLES

**2, 4, 6**

GRANDEZZA MOTORE / MOTOR SIZE / MOTORBAUGRÖSSE / TAILLE MOTEUR

**63 - 132** ( motore IEC / IEC motor / IEC motoren / moteur CEI)

MOTORE / MOTOR TYPE / MOTORTYP / TYPE MOTEUR

**BN** = trifase IEC / IEC 3-phase / IEC-Motor (Dreiphasen) / 3 phase CEI

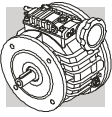

## 18.4 - Opzioni

### PV

Anelli di tenuta in fluoro-elastomero.

### SO

I Variatori V 0.25...V 10 solitamente forniti con lubrificante da Bonfiglioli Riduttori sono forniti privi di lubrificante.

Questa opzione non è prevista per i variatori con differenziale VD 0.5...VD 10 con ingresso P(IEC) in quanto normalmente forniti privi di lubrificante.

### CU

A richiesta si può fornire il variatore/motovariatore con cassa universale con piano di appoggio spianato e relativi fori di fissaggio. Questa opzione è disponibile esclusivamente per la forma costruttiva F nelle grandezze V 3...V 5.5 normalmente fornite con cassa priva di piani di appoggio e fori di fissaggio.

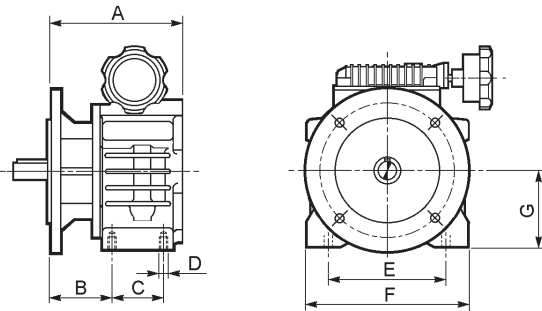

### FL

L'opzione FL comprende la succitata opzione CU a questa aggiungendo la lavorazione dei due piani laterali più la foratura e maschiatura dei fori di fissaggio. Questa opzione è disponibile per le forme costruttive F e U nelle grandezze V 3... V 10 normalmente fornite con cassa priva di tali lavorazioni.

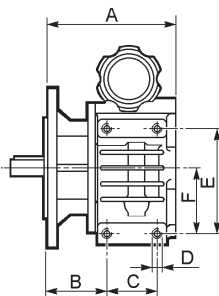

	A	B	C	D	E	F	G	H	I	L
V 3	215	79	120	M12x22	165	95	213	77	264	132
V 5.5	215	79	120	M12x22	165	95	213	77	264	132
V 10	255.5	102.5	132	M12x30	220	110	254.5	101.5	340	170

N.B. Le dimensioni non riportate si possono rilevare da pag. 50 a pag. 81.

## 18.4 - Options

### PV

Fluoro elastomer oil seals.

### SO

Variators V 0.25...V 10, usually filled with oil by Bonfiglioli Riduttori, are delivered without no lubricant.

The above option is not available for variators with differential unit VBG VD 0.5...VD 10 with IEC adapter P(IEC), since they are usually delivered without lubricant.

### CU

On request, flange mounted (F version) V units in sizes 3 through 5.5, usually supplied with no fixing holes, can be supplied with machined bottom surface with drilled and tapped holes.

### FL

The FL option incorporates the CU option only adding the extra machining plus drilling and tapping of holes on side surfaces. Available for the F and U configuration of V units, size 3 through 10, usually supplied without side machining.

NOTE: missing sizes are indicated at page 50 through 81.

## 18.4 - Optionen

### PV

Dichtringe aus Fluor-Elastomer.

### SO

Die üblicherweise von Bonfiglioli Riduttori mit Schmiermittel gelieferten Verstellgetriebe V 0.25...V 10 werden ohne Schmiermittel geliefert. Diese Option ist für die Verstellgetriebe mit Differential VD 0.5...VD 10 mit Antrieb P(IEC) nicht vorgesehen, da sie standardmässig ohne Schmiermittel geliefert werden.

### CU

Auf Anfrage kann das Verstellgetriebe bzw. der Verstellgetriebemotor mit einem Universalgehäuse mit bearbeitetem Boden und Montagebohrungen geliefert werden. Diese Option ist ausschließlich für die Bauform F in den Baugrößen V 3...V 5.5 verfügbar, die normalerweise mit einem unbearbeiteten Gehäuse ohne Montagebohrungen ausgeliefert werden.

### FL

Auf Anfrage kann das Verstellgetriebe bzw. der Verstellgetriebemotor mit einem Universalgehäuse mit bearbeiteten Seitenflächen und Montagebohrungen geliefert werden. Diese Option ist für die Bauformen F und U in den Baugrößen V 3... V 10 verfügbar, die normalerweise mit einem unbearbeiteten Gehäuse ausgeliefert werden.

ACHTUNG: Die nicht aufgeführten Maße sind auf den Seiten 50 zu finden 81.

## 18.4 - Options

### PV

Bagues d'étanchéité en Elastomère fluoré.

### SO

Les variateurs V 0.25...V 10 habituellement fournis avec du lubrifiant Bonfiglioli Riduttori sont fournis sans lubrifiant.

Cette option n'est pas prévue pour les variateurs avec différentiel VD 0.5...VD 10 avec entrée P(IEC) dans la mesure où ils sont normalement fournis sans lubrifiant.

### CU

Sur demande, le variateur /motovariateur en carter universel avec plan d'appui usiné et orifices de fixation correspondants est disponible. Cette option est disponible uniquement pour la forme de construction F, dans les tailles V 3...V 5.5 normalement fournies en carter sans plan d'appui et orifices de fixation.

### FL

Sur demande, le variateur /motovariateur en carter universel avec flancs latéraux usinés et orifices de fixation correspondants est disponible. Cette option est disponible uniquement pour les formes de construction F et U, dans les tailles V 3... V 10 normalement fournies en carter ne présentant pas se type d'usinage.

N.B. : Les dimensions non mentionnées sont indiquées de la page 50 à la page 81.

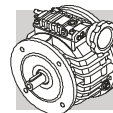

## PDN

A richiesta si può fornire il variatore con predisposizione al rilevamento di giri digitale incorporato all'interno del variatore con sonda rilevatrice di tipo NPN.

L'applicabilità alle varie configurazioni di variatore e il diametro della sonda sono rilevabili nella tabella (C03).

Caratteristiche sonda rilevatrice:

Sonda di prossimità induttiva schermata NPN in contenitore filettato con indicatore a led dello stato di uscita e cavo di connessione (lunghezza approssimativa 2 m).

La portata massima del segnale è di circa 10 m, per distanze superiori consultare il ns. Servizio tecnico commerciale.

## PDN

*On request a digital speed detector can be supplied. Sensor is NPN type.*

*Availability of the option as well as plug threading are shown in table (C03).*

*Features of the speed sensor:*

*NPN shielded inductive proximity sensor housed into a threaded plug complete with led indicator for operation mode and connecting cable (approx. 2 m long).*

*Max. signal capacity is approx 10 m, for longer distance please contact our Service Dept.*

*The built-in phonic wheel is 10 pulses per turn rated.*

## PDN

Auf Anfrage kann das Verstellgetriebe bzw. der Verstellgetriebemotor für eine digitale Drehzahlmittlung vorbereitet werden. Diese ist im Verstellgetriebe eingebaut und arbeitet mit einer Meßsonde vom Typ NPN. Die Anbaumöglichkeiten an die verschiedenen Konfigurationen der Verstellgetriebe und der Masse können der Tabelle (C03) entnommen werden.

Merkmale der Meßsonde:

Abgeschirmte induktive NPN-Näherungssonde in einem Gehäuse mit LED-Anzeige für den Abtriebszustand inklusive Anschlußkabel (ca. 2 m Länge).

Die maximale Reichweite des Signals beträgt etwa 10 m; bei größeren Entfernungen wenden Sie sich bitte an unseren technischen Kundendienst.

## PDN

*Sur demande, le variateur/motoreur avec sonde de détection de type NPN permettant la détection digitale du nombre de tours est disponible.*

*Les possibilités d'application aux différentes configurations de variateur ainsi que le diamètre de la sonde sont indiqués dans le tableau (C03).*

*Caractéristiques sonde de détection :*

*Sonde de proximité inductive blindée NPN dans un conteneur fileté avec indicateur à DEL de l'état de sortie et câble de branchement (longueur approssimative 2 m).*

*La portée du signal est d'environ 10 m, pour des distances supérieures, contacter notre Service Après-Vente.*

*La roue phonique fournie 10 impulsions par minute.*

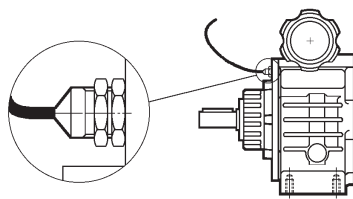

## PDP

Con caratteristiche generali come l'opzione precedente PDN ma con sonda di prossimità induttiva schermata PNP in contenitore filettato con indicatore a led dello stato di uscita e cavo di connessione (lunghezza approssimativa 2 m.).

## PDP

*Option is similar to PDN and only differs by the type of sensor which is PNP (positive - negative - positive) instead. Same features as for plug, led indicator, phonic wheel and cable (~ 2 m long).*

## PDP

Technische wie die vorhergehende PDN-Option, aber mit abgeschirmter induktiver PNP-Näherungssonde in einem Gehäuse mit LED-Anzeige für den Abtriebszustand inklusive Anschlußkabel (ca. 2 m Länge).

## PDP

*Principales caractéristiques identiques à l'option PDN précédente mais avec sonde de proximité inductive blindée PNP dans un conteneur fileté avec indicateur à DEL de l'état de sortie et câble de branchement (longueur approssimative 2 m).*

(C03)

Grandezza variatore Size unit Baugröße Verstellgetriebe Taille variateur	Sonda Plug thread Sonde Sonde (NPN/PNP)	Forme costruttive / Versions Bauformen / Formes de construction			
		V_			
		F	UP	UF	UPF
V 0.25	M8x1		A		A
			B #		B #
			C #		C #
V 0.5 VD 0.5	M8x1		A		A
			B #		B #
			C #		C #
V 1 VD 1	M10x1		A		A
			B #		B #
			C #		C #
V 2 VD 2	M10x1		A		A
			B #		B #
			C #		C #

Grandezza variatore Size unit Baugröße Verstellgetriebe Taille variateur	Sonda Plug thread Sonde Sonde (NPN/PNP)	Forme costruttive / Versions Bauformen / Formes de construction		
		V_		
		F	U	P
VR 0.25	M8x1			A
				B #
				C #
VR 0.5 VRD 0.5	M8x1			A
				B #
				C #
VR 1 VRD 1	M10x1			A
				B #
				C #
VR 2 VRD 2	M10x1			A
				B #
				C #

Grandezza variatore Size unit Baugröße Verstellgetriebe Taille variateur	Sonda Plug thread Sonde Sonde (NPN/PNP)	Forme costruttive / Version Bauformen / Formes de construction				
		V_			V_D	
		F	U-UF-UP	UF Nema	F	U-UF-UP
V 3	M12x1				#	#
					#	#
V 5.5	M12x1				#	#
					#	#
V 10	M12x1				#	#
					#	#

A - B - C

Posizione piedi riportati  
Bolt-on feet position  
Einbaulage der Füßen  
Position de montage de pieds

Applicazioni disponibili  
Option availability  
Zur Verfügung stehende Anwendungen  
Applications disponibles

#

Esecuzioni speciali a richiesta  
Special executions on demand  
Sonderausführungen auf Anfrage  
Executions speciaux sur demande

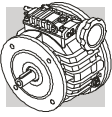

### 18.5 - Tipi di comando

I variatori possono essere dotati di vari tipi di comando, manuali o elettrici, per la variazione della velocità.  
Nel presente capitolo riportiamo i tipi disponibili, le relative caratteristiche e la loro designazione. Di seguito è riportato un esempio di designazione che evidenzia un tipo di comando.

### 18.5 - Speed control types

Variators can be equipped with different types of speed controls, either manual or electric, for a stepless speed variation.  
This chapter deals with features and designations for the speed control devices available.  
The following example highlights a specific type of remote speed control.

### 18.5 - Verstellrichtungen

Die Verstellgetriebe können mit verschiedenen manuellen oder elektrischen Verstellrichtungen zur Änderung der Drehzahl ausgestattet werden.  
Im vorliegenden Kapitel werden die zur Verfügung stehenden Typen, die entsprechenden Merkmale und ihre Bezeichnungen aufgeführt. Im Folgenden ist ein Beispiel für eine Ausführung einer Verstellrichtung dargestellt.

### 18.5 - Type de commande

Les variateurs peuvent être équipés de différents types de commandes, manuelles ou électriques, pour la variation de la vitesse.  
Les types disponibles, leurs caractéristiques ainsi que leur désignation sont indiqués dans ce chapitre. Un exemple de désignation, qui illustre un type de commande, est indiqué ci-après.

V 0.5 U F71 D14 P71 B3 1

**SCT**

Tipo di comando / Control type / Verstellrichtungstyp / Type de commande

N.B. Per i tipi di comando elettrici devono essere sempre indicate tensione e frequenza scegliendole fra quelle disponibili a catalogo.

Note: On specifying remote controls, select voltage and frequency value among those available in the catalogue.

ACHTUNG: Für die elektrischen Verstellrichtungstypen müssen immer die Spannung und die Frequenz angegeben werden; die unter den im Katalog aufgeführten Werten auszuwählen sind.

N.B. : En ce qui concerne les types de commandes électriques, il est nécessaire de toujours indiquer la tension et la fréquence, après les avoir choisies parmi les disponibilités du catalogue.

### Volantino di comando

Il volantino di comando per regolazione manuale è fornito di serie quando in designazione non è specificato alcun altro tipo di comando.

### Speed setting handwheel

When no particular control type is specified, the speed knob is supplied as the standard control device.

### Handsteuerrad

Das Handrad für die manuelle Drehzahlregulierung gehört zur serienmäßigen Lieferausstattung, wenn kein anderer Verstellrichtungstyp spezifiziert wurde.

### Volant de commande

Le volant de commande pour le réglage manuel est fourni de série lorsqu'aucun autre type de commande n'est indiqué dans la désignation.

**IMPORTANTE:** Il volantino non deve mai essere azionato a motore fermo.

**IMPORTANT:** The handwheel **MUST NOT** be turned when the variator is at standstill.

**WICHTIG:** Das Handrad darf bei stehendem Verstellgetriebemotor niemals betätigt werden.

**IMPORTANT :** Le volant de commande à main ne doit jamais être actionné motovariateur à l'arrêt .

Tipo di comando / Control type  
Verstellrichtungstyp / Type de commande

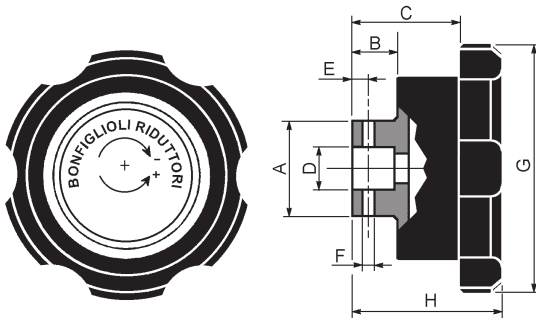

Dimensioni del codolo di attacco volantino sulla vite di comando.

Dimensions of the speed control shaft extension.

Maße des Anschlußzapfens des Handrads an die Steuerungschraube.

Dimension de la queue de fixation volant sur la vis de commande

V 0.25 - V 0.5 - V 1 - V 2

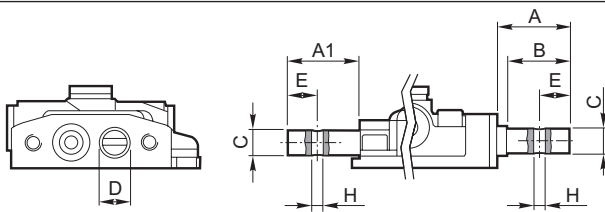

V 3 - V 5.5 - V 10

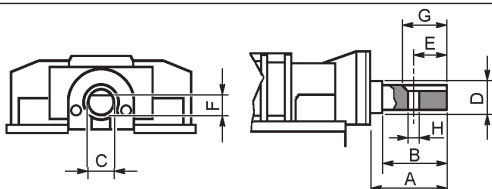

	A	B	C	D	E	F	G	H
V 0.25	31.5	14.5	35.5	10	5	4.4	83	50.0
V 0.5	31.5	14.5	35.5	10	5	4.4	83	50.0
V 1	31.5	14.5	35.5	10	5	4.4	83	50.0
V 2	31.5	14.5	35.5	10	5	4.4	83	50.0
V 3	31.5	18.5	39.5	14	5	4.4	109	56.5
V 5.5	31.5	18.5	39.5	14	5	4.4	109	56.5
V 10	31.5	18.5	39.5	14	5	4.4	109	56.5

	A	A1	B	C <sub>g7</sub>	D	E	F	G	H <sub>H7</sub>
V 0.25	25	28.5	21	10	12	12	—	—	4
V 0.5	25	28.5	21	10	12	12	—	—	4
V 1	25	28.5	21	10	12	12	—	—	4
V 2	25	28.5	21	10	12	12	—	—	4
V 3	31.5	—	29	14	14	15	12	17.5	4
V 5.5	31.5	—	29	14	14	15	12	17.5	4
V 10	35	—	34	14	15	15	12	17.5	4



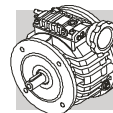

### Volantino di comando con indicatore gravitazionale

Con la designazione sotto riportata viene fornito il volantino di comando per regolazione manuale corredato di un indicatore di posizione a reazione gravitazionale che indica, su una doppia scala graduata, i giri compiuti dal volantino stesso durante il movimento di rotazione. Questo indicatore può operare solo con l'asse orizzontale o avente piccoli angoli di inclinazione (max. 15°).

**IMPORTANTE:** Il volantino non deve mai essere azionato a motore fermo.

### Speed knob with gravitational turns indicator

By specifying the VG code a speed knob complete with gravitational turns indicator, manually operated, is supplied. The handwheel features a double graduated scale counting the number of revolutions corresponding to the speed adjustment. Due to the gravitational operation the device only works horizontally or under small incline angles (max. 15°).

**WARNING:** Never turn the speed control knob when variator is at standstill.

### Handrad mit Schleppanzeige

Bei Angabe der unten aufgeführten Bezeichnung wird das Handrad für die manuelle Regulierung mit einer Lageanzeige geliefert. Dieses Instrument zeigt auf einer doppelten Gradskala die vom Handrad durchgeführten Umdrehungen an. Es kann nur in waagrecht liegender Achse oder mit leicht davon abweichenden Neigungswinkeln arbeiten (max. 15°).

**WICHTIG:** Das Handrad darf bei stehendem Verstelltriebemotor niemals betätigt werden.

### Volant de commande avec indicateur gravitationnel

La désignation indiquée ci-après permet la fourniture du volant de commande pour réglage manuel équipé d'un indicateur de position à réaction gravitationnelle qui indique, sur une double échelle graduée, les tours effectués par le volant durant le mouvement de rotation. Cet indicateur peut opérer uniquement avec l'axe horizontal ou ayant de faibles angles d'inclinaison (max. 15°).

**IMPORTANT :** Le volant de commande à main ne doit jamais être actionné moteur à l'arrêt.

Tipo di comando  
Control type  
Verstellrichtungstyp  
Type de commande

**VG**

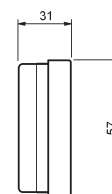
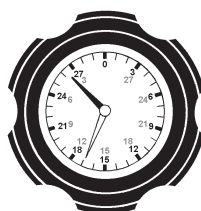

La tabella (C04) riporta il numero di giri (nv) del volantino di comando in relazione al numero di giri in uscita al variatore e alla posizione del volantino stesso (1-2). I dati (indicativi) sono riferiti ai motorvariatori con una velocità in entrata di 1400 min<sup>-1</sup> (motori a 4 poli) e dotati dei tipi di comando VG e VAG.

The table (C04) below shows relation between the number of turns of the speed knob (nv) and output speed of variator, depending on position of handwheel (1-2). Data are indicative only and relate to variators driven by 4 pole motors ( $n_1=1400 \text{ min}^{-1}$ ) equipped by either VG or VAG speed knob.

Die Tabelle (C04) zeigt die Umdrehungen (nv) des Handrades im Verhältnis zur Umdrehungszahl am Verstelltriebemotor und zur Lage des Handrads (1 – 2) selbst. Die Daten beziehen sich auf Verstelltriebemotoren mit einer Antriebsdrehzahl von 1400 min<sup>-1</sup> (vierpolige Motoren), die mit den Verstellrichtungen VG und VAG ausgestattet sind. Bei den Angaben handelt es sich um ungefähre Werte.

Le tab. (C04) indique le nombre de tours (nv) du volant de commande en fonction du nombre de tours en sortie du variateur et de la position du volant (1-2). Les caractéristiques (indicatives) concernent des motorvariateurs avec une vitesse en entrée de 1400 min<sup>-1</sup> (moteurs à 4 pôles) et dotés des types de commande VG et VAG.

(C04)

nv	V 0.25		V 0.5		V 1		V 2		V 3 - V 5.5		V 10	
	1 / 2	1 / 2	1 / 2	1 / 2	1 / 2	1 / 2	1	2	1	2	1	2
0	910	1000	1000	1000	1000	1000				1000		1000
1	840	947	970	970					955			961
2	794	894	937	942					908			923
3	737	843	902	918					856	190		887
4	681	794	867	885					808	208		852
5	630	750	837	857					762	234		813
6	578	703	804	831					719	262		783
7	529	656	772	801					679	286		750
8	480	615	735	770					643	312		716
9	435	575	708	742	190				601	339		681
10	390	535	680	718	239				561	367		650
11	344	496	656	695	274				524	395		615
12	302	458	628	670	310				486	424		583
13	262	422	600	646	344				450	455		551
14	210	387	574	622	381				412	487		520
15	190	352	548	600	417				379	516		488
16		318	523	579	453				339	549		458
17		286	497	556	490				301	580		428
18		253	473	532	526				269	610		399
19		222	450	511	567				235	643		372
20		190	426	490	605				190	676		344
21			402	470	647					708		316
22			380	450	684					741		288
23			358	428	724					777		262
24			336	410	765					810		234
25			315	391	810					843		212
26			297	371	859					881		190
27			276	353	908					915		
28			256	333	954					952		
29			235	315								
30			215	295	1000					1000		
31			200	277								
32			190	259								
33				241								
34				223								
35				205								
36				190								

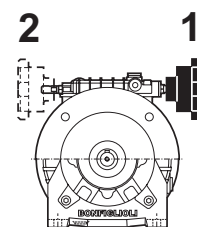

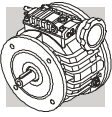

## Comando ortogonale

Il comando ortogonale permette un orientamento del comando diverso dallo standard grazie alla possibilità di essere ruotato con un angolo di 180° e permette inoltre l'utilizzo di prolungamenti del comando qualora il variatore sia posizionato in zone di difficile accesso. È previsto in tre esecuzioni con le seguenti designazioni:

- **A**: con codolo di attacco,
- **VA**: con volantino per regolazione manuale,
- **VAG**: con volantino e indicatore di posizione gravitazionale.

**IMPORTANTE:** Il comando ortogonale non deve mai essere azionato a motovariatore fermo.

## Angular speed control device

The 90° extended drive shaft allows speed adjustment under any angle within a 180° range. The free shaft end (code A) also provides for manual speed adjustment, through an extended shaft, when the variator is out of reach or hard to access. The device is available in three configurations coded as following:

- **A**: with free shaft end
- **VA**: with manual speed knob
- **VAG**: with speed knob and gravitational turns indicator.

**IMPORTANT:** Never operate the speed control device when variator is at standstill.

## Verstellrichtung mit Handrad in rechtwinkliger Anordnung

Die rechtwinklige Verstellrichtung ermöglicht ein vom Standard abweichendes Ausrichten des Handrades, da es um einen Winkel von 180° gedreht werden kann. Darüber hinaus erlaubt sie den Einsatz von Verlängerungen für den Fall, in denen das Verstellgetriebe in schwer zugänglichen Bereichen untergebracht wurde. Sie ist in drei Ausführungen mit folgenden Bezeichnungen lieferbar:

- **A**: mit Anschlußzapfen,
- **VA**: mit Handrad für manuelle Regulierung,
- **VAG**: mit Handrad und Lageanzeige.

**WICHTIG:** Die Winkelverstellung darf bei stehendem Verstelltriebemotor niemals betätigt werden.

## Commande orthogonale

La commande orthogonale permet une orientation de la commande différente de l'orientation standard car il est possible de la tourner avec un angle de 180°, de plus, elle permet l'utilisation de rallonges de la commande lorsque le variateur est positionné dans une zone difficile d'accès. Trois réalisations sont prévues, avec les désignations suivantes :

- **A** : avec queue de fixation
- **VA** : avec volant de réglage manuel
- **VAG** : avec volant et indicateur de position gravitationnel.

**IMPORTANT :** La commande orthogonale ne doit jamais être actionnée motovariateur à l'arrêt.

Tipo di comando  
Control type  
Verstellrichtungstyp  
Type de commande

**A**

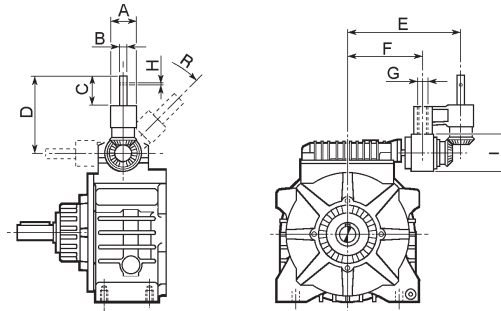

Tipo di comando  
Control type  
Verstellrichtungstyp  
Type de commande

**VA**

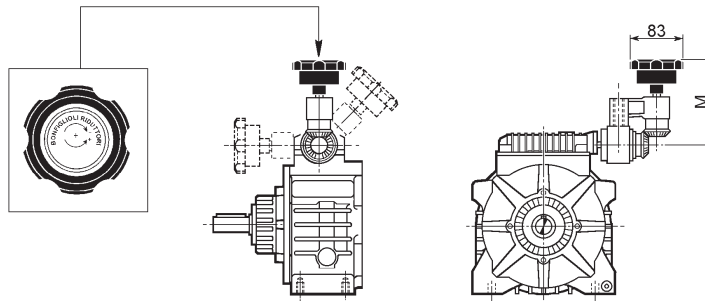

Tipo di comando  
Control type  
Verstellrichtungstyp  
Type de commande

**VAG**

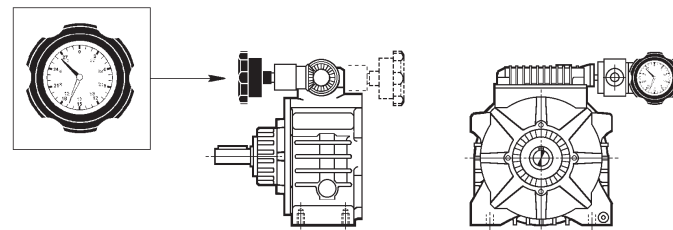

Le caratteristiche dell'indicatore gravitazionale sono riportate nel paragrafo 20.0  
Gravitational turns indicator features are indicated at paragraph 20.0  
Die Merkmale der Lageanzeige sind im Paragraphen 20.0 aufgeführt.  
Les caractéristiques de l'indicateur gravitationnel sont indiquées au paragraphe 20.0

	A	B <sub>g7</sub>	C	D	E	F	G	H	I	M	R
<b>V 0.25</b>	25	12	33	81	122	85	M10x15	4	38	114	180°
<b>V 0.5</b>	25	12	33	81	122	85	M10x15	4	38	114	180°
<b>V 1</b>	25	12	33	81	140	103	M10x15	4	38	114	180°
<b>V 2</b>	25	12	33	81	144	107	M10x15	4	38	114	180°
<b>V 3</b>	25	12	33	81	162.5	125.5	M10x15	4	38	114	180°
<b>V 5.5</b>	25	12	33	81	162.5	125.5	M10x15	4	38	114	180°
<b>V 10</b>	25	12	33	81	183.5	146.5	M10x15	4	38	114	180°

N.B. Definita la posizione di utilizzo del comando ortogonale utilizzare il foro G per l'arresto antirrotazione.

Note: once the orientation of the right angle control is fixed, use the hole G to lock position.

ACHTUNG: Wurde die Einbaulage der rechtwinkligen Verstellrichtung einmal festgelegt, muß die Arretierung der Bohrung G verwendet werden.

N.B. : Une fois définie la position d'utilisation de la commande orthogonale, utiliser l'orifice G pour l'arrêt anti-rotation.

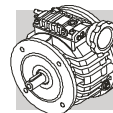

**Servocomando elettrico a distanza  
SERVOCOM**

Il servocomando elettrico SERVOCOM è costituito da un motore asincrono trifase 230/400V 50 Hz e da un riduttore a vite senza fine con limitatore di coppia. È provvisto di un limitatore di coppia che disimpegna il motorino pilota quando vengono raggiunte le velocità massima e minima del variatore (tempo max. d'intervento 6-8 s.).

**IMPORTANTE:** Il servocomando non deve mai essere azionato a motovariatore fermo.

**Electric remote control  
- SERVOCOM**

The SERVOCOM drive consists basically of 230/400V 50 Hz three-phase AC motor and a worm gearbox with torque limiter. The torque limiter switches the pilot motor off when the max or min speed setting is reached. Delay is 6-8 s.

**WARNING:** never operate the remote control when the variator is at standstill.

**Elektrische Servo-Fernverstelleinrichtung  
SERVOCOM**

Die elektrische Servo-Fernverstelleinrichtung SERVOCOM besteht aus einem dreiphasigen Asynchronmotor 230/400V und einem Schnekenuntersetzungsgetriebe mit Rutschkupplung als Drehmomentbegrenzung. Durch die Rutschkupplung wird der Steuermotor bei Erreichung der Höchstoder Mindestgeschwindigkeit des Verstellgetriebes abgestellt (maximale Eingriffszeit 6-8 Sek.).

**ACHTUNG:** Bei stehendem Verstelltriebemotor darf die Servoverstelleinrichtung niemals betätigt werden.

**Servocommande électrique à distance  
SERVOCOM**

La servocommande électrique SERVOCOM est constituée d'un moteur asynchrone triphasé 230/400V 50Hz et d'un réducteur à vis sans fin avec limiteur de couple. Elle est aussi pourvue d'un limiteur de couple qui désactive le moteur pilote lorsque les vitesses minimum et maximum du variateur sont atteintes (temps maxi. d'intervention 6-8 s.).

**IMPORTANT :** La servocommande ne doit jamais être actionnée lorsque le motovariateur est arrêté.

Tipo di comando  
Control type  
Verstelleinrichtungstyp  
Type de commande

**SCT**

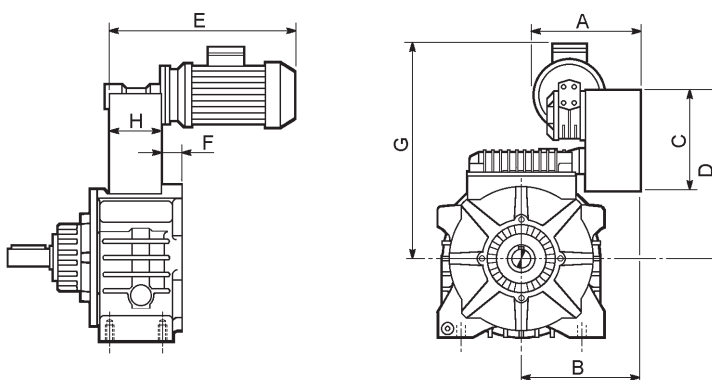

	A	B	C	D	E	F	G	H
V 0.25	121	105	129.5	166.5	229.5	12	237	72
V 0.5	121	105	129.5	174.5	229.5	15	245	72
V 1	121	123	129.5	193.5	237.5	26	264	77
V 2	121	127	129.5	209.5	237.5	41	280	77
V 3	141	169	130	247	227	57.5	318	67
V 5.5	141	169	130	247	227	57.5	318	67
V 10	141	177	130	303	253	74.5	374	67

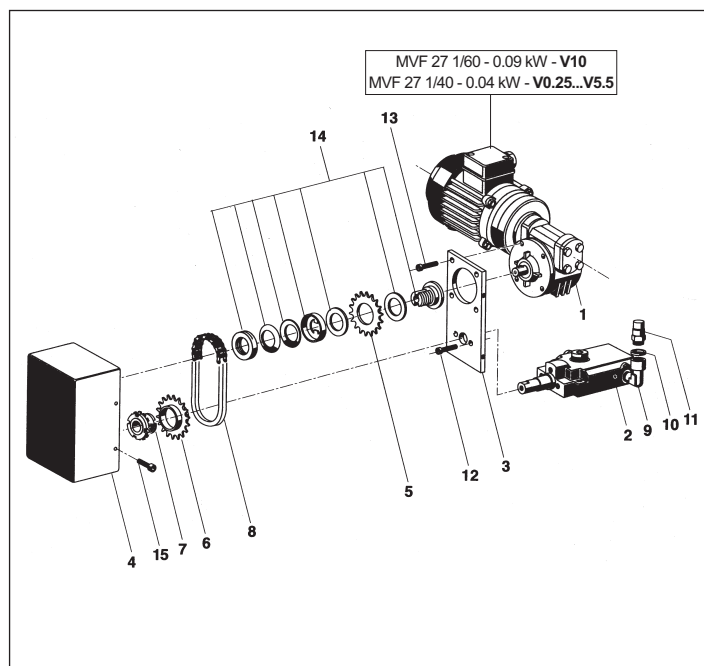

1	Servomotore	Servo motor	Servomotor	Servomoteur
2	Coperchio di comando	Speed control cover	Abdeckung der Verstelleinrichtung	Couvercle de commande
3	Supporto	Support	Montageplatte	Support
4	Coperchio di chiusura	Protection cover	Schutzhaube	Couvercle de fermeture
5	Ruota per catena	Chain sprocket	Kettenrad	Roue pour chaîne
6	Ruota per catena	Chain sprocket	Kettenrad	Roue pour chaîne
7	Calettatore	Cone Clamping	Spannbüchse	Moyeu de serrage
8	Catena	Chain	Kette	Chaîne
9	Raccordo angolare	Angular pipe	Winkelschraubung	Raccord coudé
10	Guarnizione	Gasket	Dichtung	Joint plat
11	Tappo sfiato	Breather plug	Entlüftungsstopfen	Bouchon de purge
12	Vite	Bolt	Schraube	Vis
13	Vite	Bolt	Schraube	Vis
14	Limitatore di coppia	Torque limiter	Rutschkupplung	Vis d'arrêt
15	Vite	Bolt	Schraube	Vis

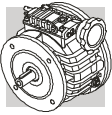

**Elettrocomando a bassa tensione con finecorsa elettronici TELECOM**

L' elettrocomando TELECOM, è costituito da un servomotore alimentato a 24 Vdc installato sul variatore e da una scheda logica di controllo, con fine corsa elettronici incorporati, installabile nell'armadio elettrico a bordo macchina. È disponibile nelle grandezze V 0.25...V 2.

**CARATTERISTICHE TECNICHE:**

- Alimentazione e pilotaggio secondo le più severe normative vigenti.
- Ingombri e pesi contenuti.
- Precisione di regolazione.
- Arresto istantaneo su battute meccaniche eseguito tramite la scheda elettronica di controllo.
- Controllo elettronico con memoria non volatile delle informazioni di funzionamento indipendente dall'alimentazione generale della macchina.
- Ottimizzazione dell'erogazione di coppia nelle varie fasi del funzionamento (avviamento, rotazione, arresto, inversione).
- Cablaggio semplificato rispetto agli attuali servocomandi di uso corrente.
- Alimentazione 24 Vdc/18Vac.
- Possibilità di pilotaggio da PLC.

**IMPORTANTE:**  
L'elettrocomando non deve mai essere azionato a motoriatore fermo.

**Low voltage remote control with electronic limit switches - TELECOM**

The TELECOM electric control consists of a 24 Vdc servo motor installed on the variator and a logic control board with in-built electronic limit switches, which can be installed in the machine cabinet. Available in size units V 0.25 through V 2.

**TECHNICAL FEATURES:**

- Power supply and piloting in compliance with strictest current regulations
- Space and cost effectiveness
- Fine adjustment of speed
- Immediate stop at travelends through electronic control board
- Electronic check with solid state memory for operating conditions independent from machine main power supply
- Torque optimization during the various operating modes (start, rotation, stop and reversal)
- Simplified wiring, if compared with current servo controls
- 24 Vdc/18Vac power supply
- Piloting through PLC possible

**IMPORTANT:**  
never operate the electrocontrol when the motor variator is at standstill.

**Niederspannungs-Verstelleinrichtung TELECOM mit elektronischen Endschaltern**

Die TELECOM Verstelleinrichtung besteht aus einem mit 24 VDC gespeisten Servomotor, der auf dem Verstellgetriebe installiert ist, und aus einer Kontrollkarte mit eingebauten elektronischen Endschaltern, die im Schaltschrank installiert werden kann. Sie steht für die Baugrößen V 0.25...V 2 zur Verfügung.

**TECHNISCHE MERKMALE:**

- Ausführung nach neuesten geltenden Richtlinien.
- Kleine Maße und Gewichte.
- Präzise Einstellmöglichkeit.
- Sofortiger Halt bei Blockage, gesteuert über die elektronische Kontrollkarte.
- Elektronische Kontrolle mit nicht selbstlöschendem Speicher der Betriebsinformationen, die vom Anschluß der Maschine unabhängig ist.
- Optimierung der Drehmomentabgabe in den verschiedenen Betriebsphasen (Start, Umdrehung, Stillstand, Umkehr).
- Vereinfachte Verkabelung im Vergleich zu den heutigen allgemein üblichen Servoverstelleinrichtungen.
- Anschluß 24VDC / 18 VAC.
- Möglichkeit der Verstellung über PLC.

**ACHTUNG:**  
Bei stehendem Verstellgetriebemotor darf die Servoverstelleinrichtung niemals in Betrieb gesetzt werden.

**Electrocommande à basse tension avec fins de course électroniques TELECOM**

L'électrocommande TELECOM est constituée d'un servomoteur alimenté en 24 Vcc installé sur le variateur et d'une carte logique de contrôle avec dispositifs de fin de course électroniques incorporés, à installer dans l'armoire électrique à coté de la machine. Disponible dans les tailles V 0.25...V 2.

**CARACTERISTIQUES TECHNIQUES**

- alimentation et pilotage dans le respect des plus sévères normes en vigueur.
- Encombrements et poids limités.
- Précision de réglage.
- Arrêt instantané sur butées mécaniques au moyen de la carte électronique de contrôle.
- Contrôle électronique avec mémoire non volatile des informations de fonctionnement indépendante de l'alimentation général de la machine.
- Optimisation de la distribution de couple au cours des différentes phases de fonctionnement (démarrage, rotation, arrêt, inversion).
- Câblage simplifié par rapport aux servocommandes les plus utilisées actuellement.
- Alimentation 24 Vcc/18 Vca.
- Possibilité de pilotage depuis PLC.

**IMPORTANT :**  
L'électrocommande ne doit jamais être actionnée lorsque le motovariateur est arrêté.

Tipo di comando  
Control type  
Verstelleinrichtungstyp  
Type de commande

**TC**

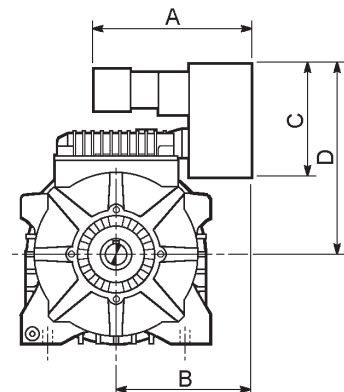
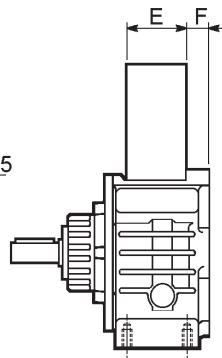
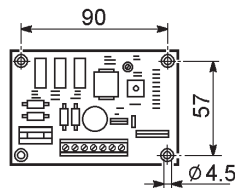

	A	B	C	D	E	F
<b>V 0.25</b>	120	92	104	144	73.5	13
<b>V 0.5</b>	120	92	104	152	73.5	15
<b>V 1</b>	120	110	104	171	78.5	27
<b>V 2</b>	120	114	104	187	78.5	42

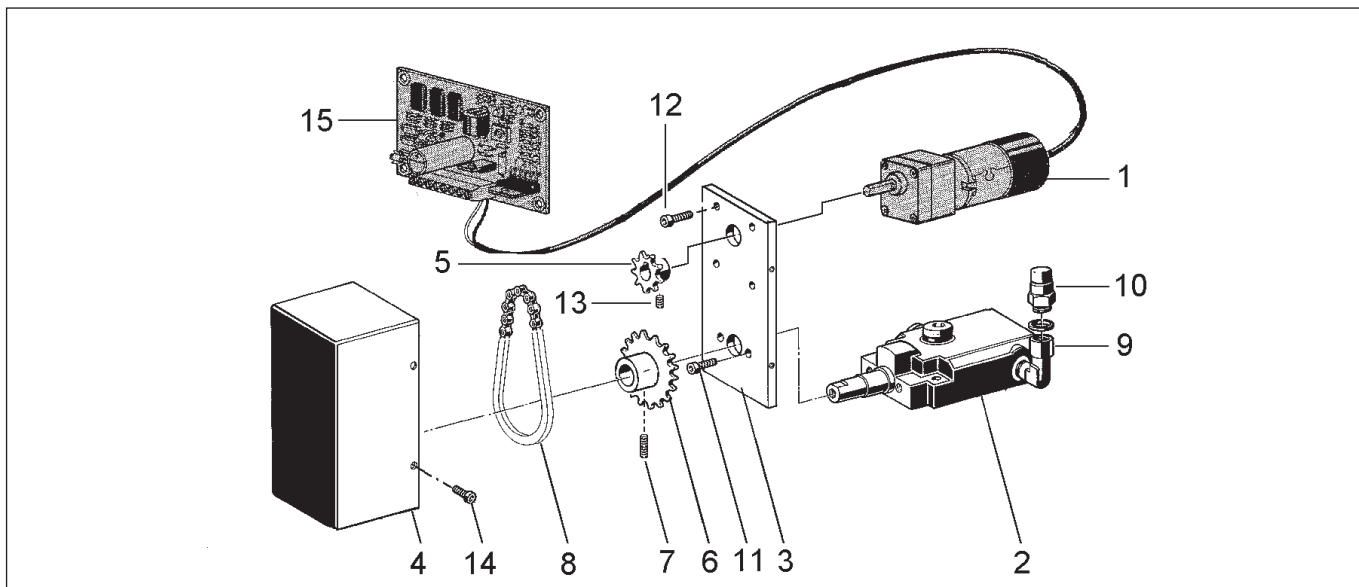
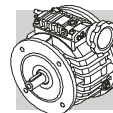

1	Servomotore	<i>Servo motor</i>	Servomotor	<i>Servomoteur</i>
2	Coperchio di comando	<i>Speed control cover</i>	Abdeckung der Verstellrichtung	<i>Couvercle de commande</i>
3	Supporto	<i>Support</i>	Montageplatte	<i>Support</i>
4	Coperchio di chiusura	<i>Closing cover</i>	Schutzhaube	<i>Couvercle de fermeture</i>
5	Pignone per catena	<i>Chain sprocket</i>	Kettenrad	<i>Roue pour chaîne</i>
6	Ruota per catena	<i>Chain wheel</i>	Kettenrad	<i>Roue pour chaîne</i>
7	Grano	<i>Grub screw</i>	Gewindestift	<i>Vis sans tête</i>
8	Catena	<i>Chain</i>	Kette	<i>Chaîne</i>
9	Raccordo angolare	<i>L- pipe</i>	Winkelverschraubung	<i>Raccord coudé</i>
10	Tappo sfiato	<i>Breather plug</i>	Entlüftungsstopfen	<i>Bouchon de purge</i>
11	Vite	<i>Bolt</i>	Schraube	<i>Vis</i>
12	Vite	<i>Bolt</i>	Schraube	<i>Vis</i>
13	Grano	<i>Grub screw</i>	Gewindestift	<i>Vis sans tête</i>
14	Vite	<i>Bolt</i>	Schraube	<i>Vis</i>
15	Scheda elettronica	<i>Electronic card</i>	Steuerkarte	<i>Carte électronique</i>

Negli schemi seguenti riportiamo i collegamenti da effettuare per il corretto funzionamento dell'elettrocomando TELECOM.

*The following diagrams show wiring for proper operation of the TELECOM electric control.*

In den folgenden Plänen sind die Anschlüsse aufgeführt, die für die korrekte Funktion der Verstellrichtung TELECOM vorgesehen werden müssen.

*Les schémas suivants indiquent les branchements à effectuer pour obtenir un fonctionnement correct de l'électrocommande TELECOM.*

Schema di collegamento con comando ausiliario (non fornito)  
*Wiring diagram with auxiliary control (not supplied)*  
 Anschlußschema mit Hilfsverstellrichtung (nicht im Lieferumfang)  
*Schéma de branchement avec commande auxiliaire (non fournie)*

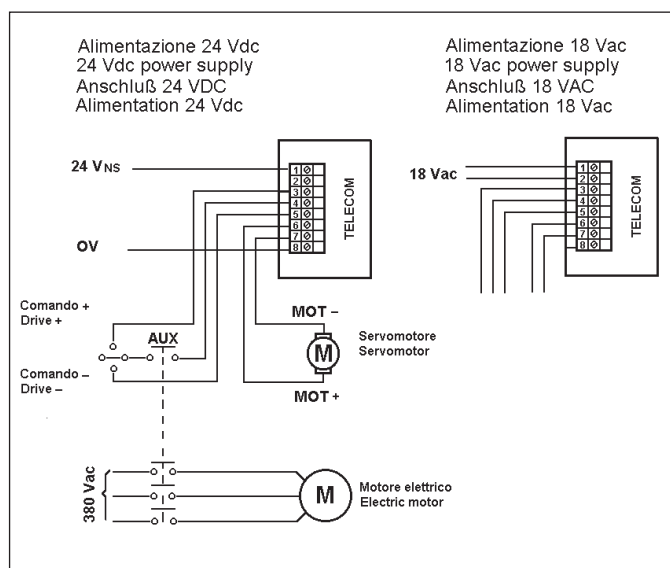

Schema di collegamento con comando da PLC (non fornito)  
*Wiring diagram with drive on PLC (not supplied)*  
 Anschlußschema mit Verstellung über PLC (nicht im Lieferumfang)  
*Schéma de branchement avec commande depuis PLC (non fournie)*

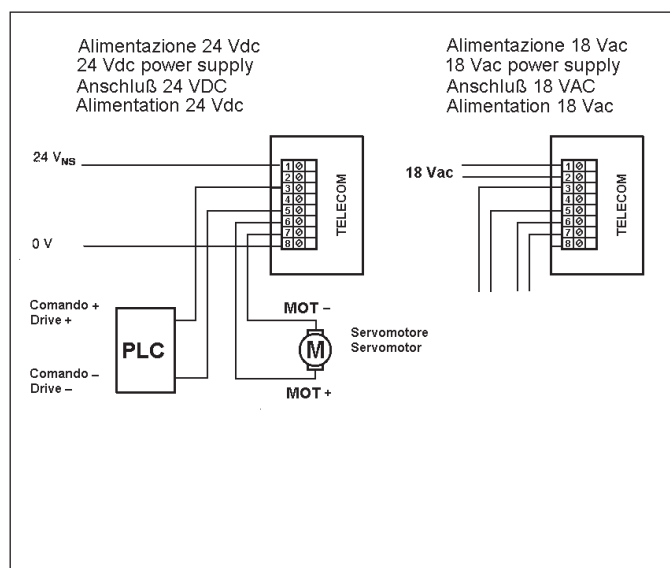

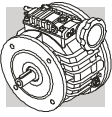

## 18.6 - Lubrificazione variatori

La lubrificazione dei variatori V e VD avviene per sbattimento dell'olio.

Prima della messa in funzione dei variatori accertarsi della presenza di olio al loro interno assicurandosi che esso compaia nella spia di livello.

### VD

Tutti i variatori con differenziale VD completi di motore vengono forniti con carico di olio. Tutti i variatori con differenziale VD in configurazione P... (IEC), vengono forniti privi di olio. In questo caso l'utente dovrà provvedere al riempimento immettendo le quantità di olio indicate nelle tabelle (C05-C06) e dovrà utilizzare motori elettrici con l'anello di tenuta lato albero e la flangia di accoppiamento al variatore a tenuta di olio.

**Benchè i variatori siano abbinabili a qualsiasi motore normalizzato IEC, BONFIGLIOLI raccomanda che siano utilizzati solo motori originali, provvisti di anelli di tenuta per l'olio.**

I variatori V 0.25 e V 0.5 vengono forniti completi di olio lubrificante "long life" sintetico **SHELL SPIRAX S4 ATF HDX**. Eventuali sostituzioni o rimbocchi dovranno essere effettuati utilizzando lo stesso tipo di prodotto.

I variatori V 1...V 10 vengono forniti completi di olio lubrificante minerale **SHELL SPIRAX S2 ATF AX**. Eventuali sostituzioni o rimbocchi potranno essere effettuati utilizzando lubrificanti compatibili.

Riduzione **R** lubrificata "a vita" con grasso **SHELL GADUS S5 V142W 00**.

Tutti i variatori sono forniti con carica di lubrificante, ad eccezione dei tipi **VD\_P(IEC)**.

Il tappo di sfiato, fornito a corredo, va posizionato come indicato nelle tabelle (C05 - C06).

## 18.6 - Lubrication of variators

*Variators V and VD are splash-lubricated.*

*Before putting the variator into operation make sure there is oil inside up to the sight glass level.*

### VD

*Motorized VD variators featuring the differential unit are factory filled with oil unlike VD variators with the IEC motor adapter (P...) which are supplied dry and must be filled with oil prior to be put into operation.*

*Proper oil quantity is shown in table (C05-C06) and relates to actual mounting position.*

**Although speed variators can match any IEC motors, BONFIGLIOLI recommends the use of genuine motors only, complete with shaft oil seals.**

*Variator units V 0.25 and V 0.5 are factory filled with "long life" synthetic oil **SHELL SPIRAX S4 ATF HDX**. Use same oil when topping up or refilling.*

*Variator units V 1 through V 10 are factory filled with mineral oil **SHELL SPIRAX S2 ATF AX**. Use same type of oil when topping up or refilling.*

*Helical reduction **R** is grease lubed "for life" with **SHELL GADUS S5 V142W 00**.*

*All speed variators are factory filled with lubricant, with the only exception of units type **VD\_P(IEC)**.*

*The breather plug, supplied along with every unit, shall be located as per the schemes (C05) and (C06).*

## 18.6 - Schmierung der Verstellgetriebe

Die Schmierung der Verstellgetriebe V und VD erfolgt durch Tauchschmierung im Ölbad.

Vor der Inbetriebnahme der Verstellgetriebe muß geprüft werden, ob sie bis zur Ölstandskontrolle mit Öl gefüllt sind.

### VD

Alle Verstellgetriebe mit Differential VD und Motor, sind bei Lieferung mit Öl gefüllt.

Alle Verstellgetriebe mit Differential V-D für den Anbau eines IEC-Motors werden ohne Öl geliefert.

Wenn der Kunde die Getriebe selbst mit Öl füllt, müssen die in Tabelle (C05-C06) angegebenen Ölmengen verwendet werden. Die zu verwendenden Motoren müssen einen Dichtring auf der Seite der Welle haben und der Flansch zur Kopplung an das Verstellgetriebe muß öldicht sein.

**Es wird empfohlen, die Verstellgetriebe mit Differential mit öldichten BONFIGLIOLI RIDUTTORI Motoren zu kaufen.**

Die Verstellgetriebe V 0.25 und V 0.5 werden mit Schmieröl **SHELL SPIRAX S4 ATF HDX** geliefert. Eventuelle Ölwechsel oder Nachfüllungen müssen unter Anwendung des gleichen Produkttyps erfolgen.

Die Verstellgetriebe V 1...V 10 werden mit dem Schmieröl **SHELL SPIRAX S2 ATF AX** geliefert. Ein eventueller Wechsel oder ein etwaiges Auffüllen sollte unter Verwendung der Schmiermittel erfolgen.

Die Vorstufe **R** ist mit Fett Typ **SHELL GADUS S5 V142W 00** gefüllt.

Alle Verstellgetriebe sind ab Werk mit Öl gefüllt, außer dem Typ **VD\_P(IEC)**.

Der Entlüftungsstopfen, der jedem Getriebe beiliegt, muss entsprechend der obigen Skizze montiert werden.

## 18.6 - Lubrification variateurs

*La lubrification des variateurs V et VD s'effectue par barbotage de l'huile.*

*Avant la mise en service des variateurs/motovariateurs, vérifier la présence d'huile à l'intérieur en contrôlant que celle-ci apparaisse dans le témoin de niveau.*

### VD

*Tous les variateurs avec différentiel VD avec moteur sont fournis avec le plein d'huile.*

*Tous les variateurs avec différentiel VD en configuration P... (IEC) sont fournis sans huile.*

*Dans ce cas, l'utilisateur doit effectuer le remplissage en versant la quantité d'huile indiquée dans le tableau (C05-C06) et doit utiliser des moteurs électriques avec bague d'étanchéité côté arbre et bride d'accouplement au variateur étanche à l'huile.*

**Dans tous les cas, il est conseillé d'acquérir des variateurs avec différentiel avec moteurs avec étanchéité à l'huile BONFIGLIOLI RIDUTTORI.**

*Les variateurs V 0.25 et V 0.5 sont fournis avec de l'huile lubrifiante "long life" **SHELL SPIRAX S4 ATF HDX**. Utiliser le même type d'huile pour les éventuels vidanges ou remplissages.*

*Les variateurs V 1...V 10 sont fournis avec de l'huile lubrifiante **SHELL SPIRAX S2 ATF AX**. Utiliser le même type d'huiles pour les éventuels vidanges ou remplissages.*

*Réduction **R** avec lubrification permanente au moyen de graisse **SHELL GADUS S5 V142W 00**.*

*Tous les variateurs sont fournis avec le lubrifiant, à l'exception des les modèles **VD\_P (IEC)**.*

*Le bouchon d'évent, fourni avec chaque variateur, doit être positionné comme indiqué dans les schémas (C05 - C06).*



Non mescolare olii di natura diversa.



Do not mix synthetic oil with mineral oil.



Auf keinen Fall darf synthetisches Öl mit mineralischem Gemischt werden!



Ne pas mélanger huiles de nature différente.

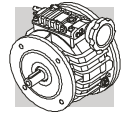

Collocazione dei tappi di carico, scarico e livello olio.

Positions of oil fill, level and drain plugs.

Anordnung des Einfüll-, Ölstands- und Ölablaßschrauben.

Position des bouchons de remplissage, niveau et vidange d'huile.

(C05)

V 0.25 - V 0.5

V 1 - V 2

B3

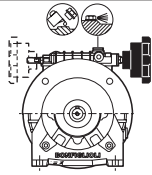

V 0.25 F	0.14	
V 0.5 F	0.18	
V 0.25 U_ / VR 0.25_	0.12	
V 0.5 U_ / VR 0.5_	0.15	
VD 0.5 U_ / VRD 0.5	0.30	

Oil SPIRAX S4 ATF HDX (for life)

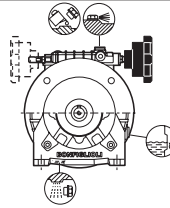

V 1 F	0.30	
V 2 F	0.40	
V 1 U_ / VR 1_	0.25	
V 2 U_ / VR 2_	0.32	
VD 1 U_ / VRD 1	0.35	
VD 2 U_ / VRD 2	0.46	

Oil SPIRAX S2 ATF AX (2000-3000 hrs.)

B6

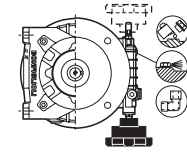

V 0.25 F	0.14	
V 0.5 F	0.18	
V 0.25 U_ / VR 0.25_	0.12	
V 0.5 U_ / VR 0.5_	0.15	
VD 0.5 U_ / VRD 0.5	0.30	

Oil SPIRAX S4 ATF HDX (for life)

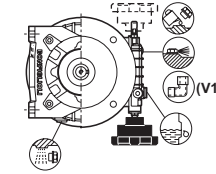

V 1 F	0.30	
V 2 F	0.40	
V 1 U_ / VR 1_	0.25	
V 2 U_ / VR 2_	0.32	
VD 1 U_ / VRD 1	0.35	
VD 2 U_ / VRD 2	0.46	

Oil SPIRAX S2 ATF AX (2000-3000 hrs.)

B7

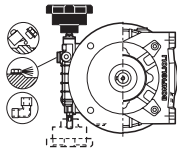

V 0.25 F	0.14	
V 0.5 F	0.18	
V 0.25 U_ / VR 0.25_	0.12	
V 0.5 U_ / VR 0.5_	0.15	
VD 0.5 U_ / VRD 0.5	0.30	

Oil SPIRAX S4 ATF HDX (for life)

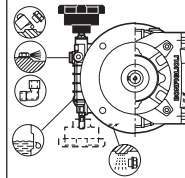

V 1 F	0.30	
V 2 F	0.40	
V 1 U_ / VR 1_	0.25	
V 2 U_ / VR 2_	0.32	
VD 1 U_ / VRD 1	0.35	
VD 2 U_ / VRD 2	0.46	

Oil SPIRAX S2 ATF AX (2000-3000 hrs.)

B8

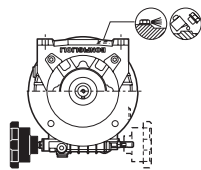

V 0.25 F	0.14	
V 0.5 F	0.18	
V 0.25 U_ / VR 0.25_	0.12	
V 0.5 U_ / VR 0.5_	0.15	
VD 0.5 U_ / VRD 0.5	0.30	

Oil SPIRAX S4 ATF HDX (for life)

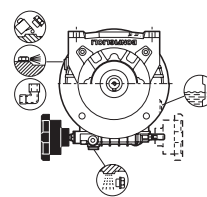

V 1 F	0.30	
V 2 F	0.40	
V 1 U_ / VR 1_	0.25	
V 2 U_ / VR 2_	0.32	
VD 1 U_ / VRD 1	0.35	
VD 2 U_ / VRD 2	0.46	

Oil SPIRAX S2 ATF AX (2000-3000 hrs.)

V5

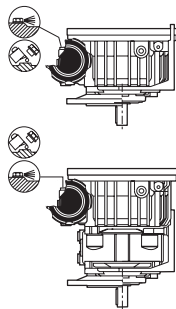

V 0.25 F	0.28	
V 0.5 F	0.30	
V 0.25 U_ / VR 0.25_	0.22	
V 0.5 U_ / VR 0.5_	0.27	

Oil SPIRAX S4 ATF HDX (for life)

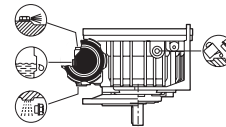

V 1 F	0.58	
V 2 F	0.78	
V 1 U_ / VR 1_	0.40	
V 2 U_ / VR 2_	0.54	

Oil SPIRAX S2 ATF AX (2000-3000 hrs.)

VD 0.5 U_ / VRD 0.5	0.70	
---------------------	------	--

Oil SPIRAX S4 ATF HDX (for life)

VD 1 U_ / VRD 1	1.00	
VD 2 U_ / VRD 2	1.5	

Oil SPIRAX S2 ATF AX (2000-3000 hrs.)

V6

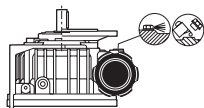

V 0.25 F	0.14	
V 0.5 F	0.18	
V 0.25 U_ / VR 0.25_	0.12	
V 0.5 U_ / VR 0.5_	0.15	

Oil SPIRAX S4 ATF HDX (for life)

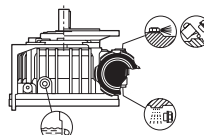

V 1 F	0.30	
V 2 F	0.40	
V 1 U_ / VR 1_	0.25	
V 2 U_ / VR 2_	0.32	

Oil SPIRAX S2 ATF AX (2000-3000 hrs.)

VD 0.5 U_ / VRD 0.5	0.40	
---------------------	------	--

Oil SPIRAX S4 ATF HDX (for life)

VD 1 U_ / VRD 1	0.50	
VD 2 U_ / VRD 2	0.70	

Oil SPIRAX S2 ATF AX (2000-3000 hrs.)

Tappo di sfiato  
Breather plug  
Entlüftungsstopfen  
Bouchon d'évent

Tappo di carico  
Filler plug  
Einfüllstopfen  
Bouchon de remplissage

Tappo di scarico  
Drain plug  
Ablassstopfen  
Bouchon de vidange

Tappo di livello  
Level plug  
Ölstandsstopfen  
Bouchon de niveau

Raccordo orientabile  
90° elbow  
90° Winkel  
Raccord coudé

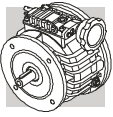

Collocazione dei tappi di carico, scarico e livello olio.

Positions of oil fill, level and drain plugs.

Anordnung des Einfüll-, Ölstands- und Ölablaßschrauben.

Position des bouchons de remplissage, niveau et vidange d'huile.

(C06)

V 3 - V 5.5

V 10

B3

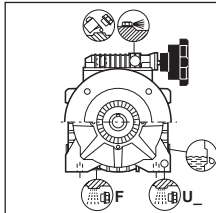

V 3 F - V 5.5 F_	0.70	
V 3 U_ / VR 3 V 5.5 U_ / VR 5.5	1.0	
VD 3 F VD 5.5 F	1.3	
VD 3 U_ / VRD 3 U VD 5.5 U_ / VRD 5.5 U_	1.6	
Oil SPIRAX S2 ATF AX (2000-3000 hrs.)		

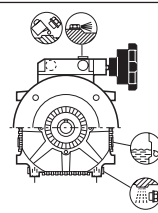

V 10 F V 10 U_ / VR 10	1.8	
VD 10 F VD 10 U_ / VRD 10 U_	2.0	
Oil SPIRAX S2 ATF AX (2000-3000 hrs.)		

B6

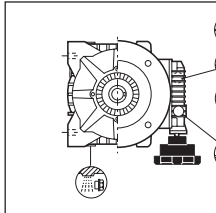

V 3 F - V 5.5 F_	0.90	
V 3 U_ / VR 3 V 5.5 U_ / VR 5.5	1.0	
VD 3 F VD 5.5 F	1.3	
VD 3 U_ / VRD 3 U VD 5.5 U_ / VRD 5.5 U_	1.6	
Oil SPIRAX S2 ATF AX (2000-3000 hrs.)		

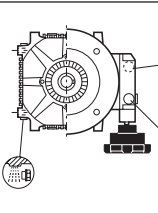

V 10 F V 10 U_ / VR 10	1.8	
VD 10 F VD 10 U_ / VRD 10 U_	2.0	
Oil SPIRAX S2 ATF AX (2000-3000 hrs.)		

B7

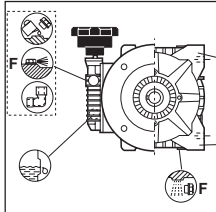

V 3 F - V 5.5 F_	0.90	
V 3 U_ / VR 3 V 5.5 U_ / VR 5.5	1.0	
VD 3 F VD 5.5 F	1.3	
VD 3 U_ / VRD 3 U VD 5.5 U_ / VRD 5.5 U_	1.6	
Oil SPIRAX S2 ATF AX (2000-3000 hrs.)		

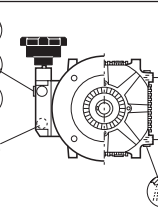

V 10 F V 10 U_ / VR 10	1.8	
VD 10 F VD 10 U_ / VRD 10 U_	2.0	
Oil SPIRAX S2 ATF AX (2000-3000 hrs.)		

B8

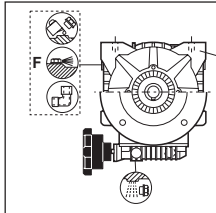

V 3 F - V 5.5 F_	1.0	
V 3 U_ / VR 3 V 5.5 U_ / VR 5.5	1.3	
VD 3 F VD 5.5 F	1.6	
VD 3 U_ / VRD 3 U VD 5.5 U_ / VRD 5.5 U_	1.9	
Oil SPIRAX S2 ATF AX (2000-3000 hrs.)		

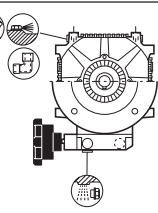

V 10 F V 10 U_ / VR 10	2.1	
VD 10 F VD 10 U_ / VRD 10 U_	2.1	
Oil SPIRAX S2 ATF AX (2000-3000 hrs.)		

V5

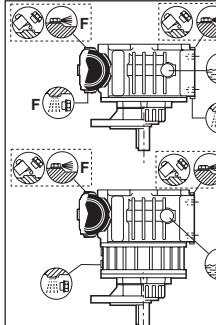

V 3 F - V 5.5 F_	2.1	
V 3 U_ / VR 3 V 5.5 U_ / VR 5.5	2.0	
Oil SPIRAX S2 ATF AX (2000-3000 hrs.)		
VD 3 F VD 5.5 F	4.5	
VD 3 U_ / VRD 3 U VD 5.5 U_ / VRD 5.5 U_	4.8	
Oil SPIRAX S2 ATF AX (2000-3000 hrs.)		

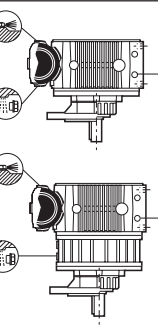

V 10 F V 10 U_ / VR 10	3.2	
Oil SPIRAX S2 ATF AX (2000-3000 hrs.)		
VD 10 F VD 10 U_ / VRD 10	8.5	
Oil SPIRAX S2 ATF AX (2000-3000 hrs.)		

V6

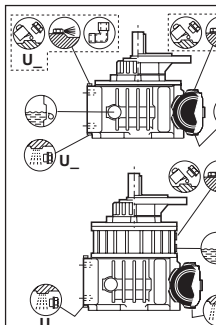

V 3 F - V 5.5 F_	1.0	
V 3 U_ / VR 3 V 5.5 U_ / VR 5.5	1.3	
Oil SPIRAX S2 ATF AX (2000-3000 hrs.)		
VD 3 F VD 5.5 F	2.8	
VD 3 U_ / VRD 3 U VD 5.5 U_ / VRD 5.5 U_	3.0	
Oil SPIRAX S2 ATF AX (2000-3000 hrs.)		

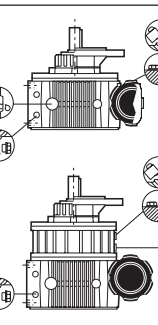

V 10 F V 10 U_ / VR 10	2.8	
Oil SPIRAX S2 ATF AX (2000-3000 hrs.)		
VD 10 F VD 10 U_ / VRD 10	7.0	
Oil SPIRAX S2 ATF AX (2000-3000 hrs.)		

Tappo di sfianto  
Breather plug  
Entlüftungstopfen  
Bouchon d'évent

Tappo di carico  
Filler plug  
Einfüllstopfen  
Bouchon de remplissage

Tappo di scarico  
Drain plug  
Ablassstopfen  
Bouchon de vidange

Tappo di livello  
Level plug  
Ölstandsstopfen  
Bouchon de niveau

Raccordo orientabile  
90° elbow  
90° Winkel  
Raccord coudé



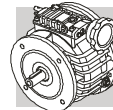

**18.7 - Posizioni di montaggio, orientamento morsettiere motore e comando variatore**

La tabella (C08) evidenzia le posizioni che può assumere il variatore.

In fase di ordine è necessario specificare oltre alla posizione di montaggio del variatore, l'orientamento della morsettiere (W, N, E, S) e del comando (1, 2) scegliendo fra le alternative illustrate nelle tabelle.

La tabella (C07) facilita l'interpretazione delle varie posizioni di montaggio riportate.

**18.7 - Mounting position, motor terminal box angular position and variator control**

Table (C08) show the mounting positions of the variator. Reducer mounting position and variator arrangement must be specified on order, as well as terminal board arrangement (W, N, E, S) and control position (1, 2). Choose from the options shown in the tables.

Table (C07) provides examples of the various mounting positions for better understanding.

**18.7 - Einbautagen, lage des Motorklemmenkastens und position der Steuerung des Verstellgetriebe**

Die Tabelle (C08) stellen die Positionen dar, die das Verstellgetriebe einnehmen kann.

In der Auftragsphase muß daher über die Montageposition des Getriebes hinaus, auch die Lage des Verstellgetriebes, die Ausrichtung der Klemmenleiste (W, N, E, S) und position der Steuerung angegeben werden, die unter den in der Tabelle angegebenen Möglichkeiten ausgewählt werden können.

Die Tabelle (C07) erleichtert die Auslegung der verschiedenen, dargestellten Einbautagen.

**18.7 - Positions de montage, orientation boîte a borne du moteur et dispositif de commande variateur**

Le tableau (C08) indiquent les positions possibles du variateur. Au moment de la commande, il est nécessaire de préciser la position de montage du réducteur ainsi que la position du variateur, l'orientation de la boîte à bornes (W, N, E, S) et la position du dispositif de commande (1, 2), en choisissant parmi les alternatives indiquées dans les tableaux.

Le tableau (C07) facilite l'interprétation des différentes positions de montage indiquées.

(C07)

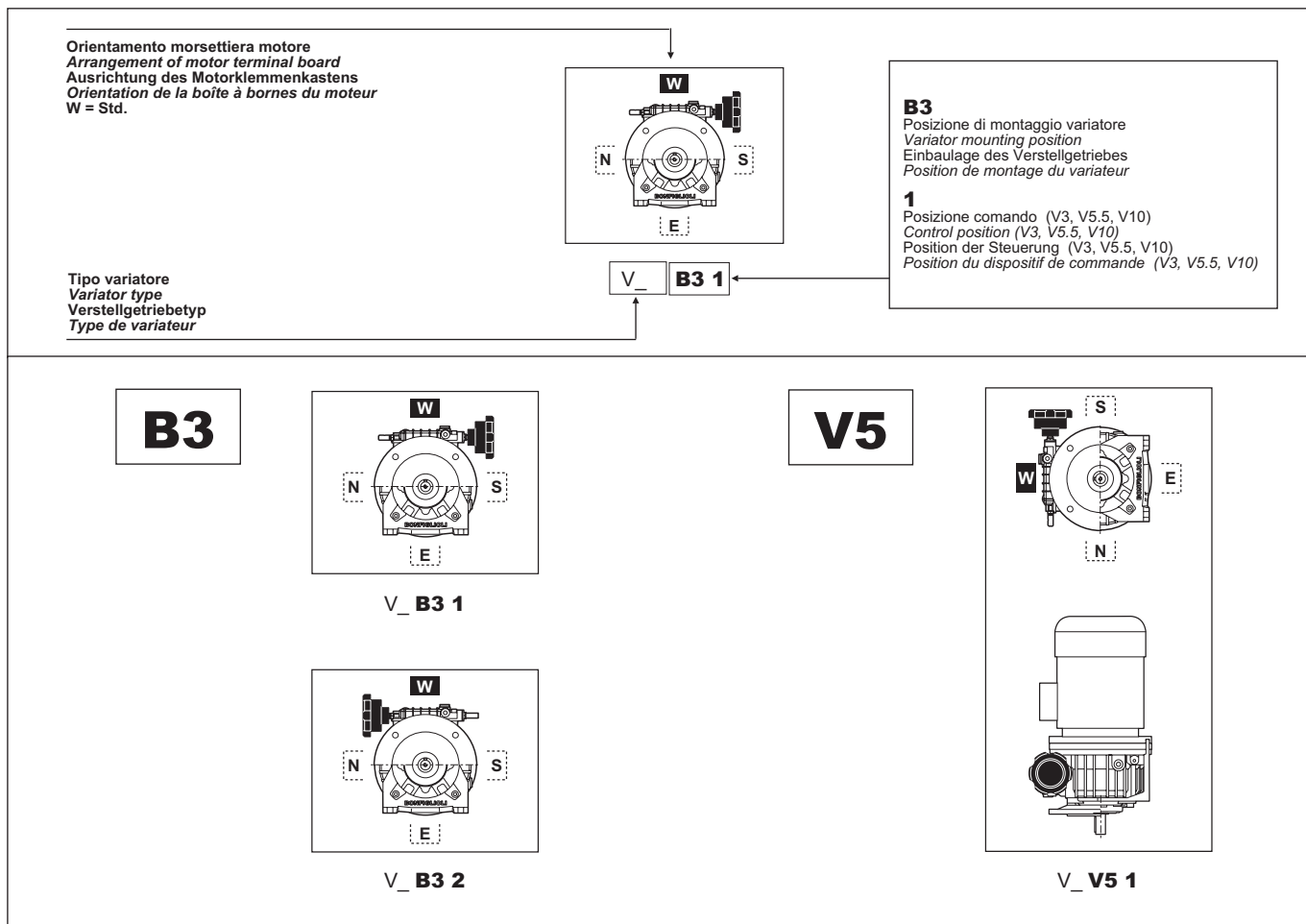

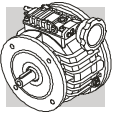

(C08)

**B3**

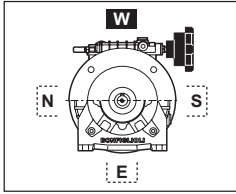

V\_B3 1

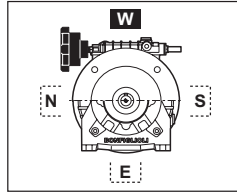

V\_B3 2

**B6**

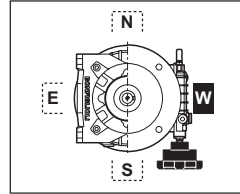

V\_B6 1

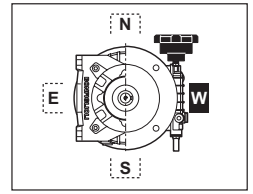

V\_B6 2

**B7**

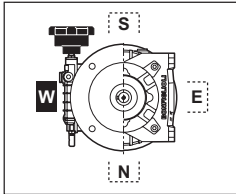

V\_B7 1

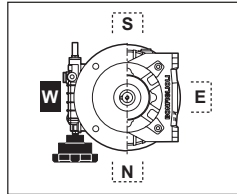

V\_B7 2

**B8**

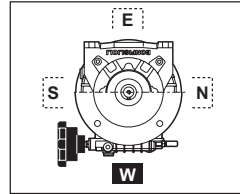

V\_B8 1

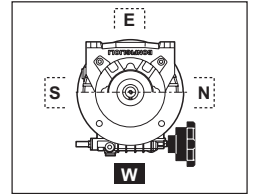

V\_B8 2

**V5**

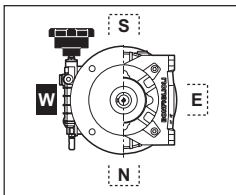

V\_V5 1

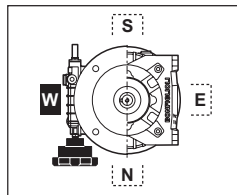

V\_V5 2

**V6**

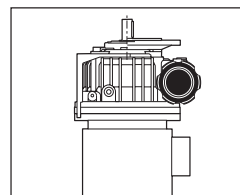

V\_V6 1

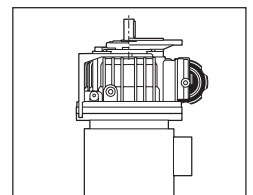

V\_V6 2

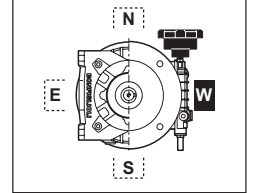
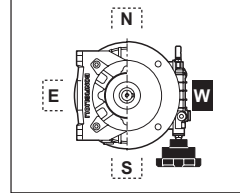

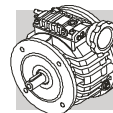



18.8 - Tabelle dati tecnici

18.8 - Rating charts



18.8 - Tabelle-technische daten

18.8 - Tableaux caracteristiques techniques

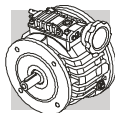
<b>V<sub>-</sub></b>											
<b>P<sub>1</sub> (kW)</b>	<b>n<sub>2</sub> min<sup>-1</sup></b>	<b>n<sub>2</sub>' min<sup>-1</sup></b>	<b>M<sub>2</sub> Nm</b>	<b>M<sub>2</sub>' Nm</b>	<b>R<sub>n1</sub> N</b>	<b>R<sub>n2</sub> N</b>	<b>R<sub>n2</sub>' N</b>				
<b>0.12</b>	604	125	1.4	3.7	400	900	1200	<b>V 0.25_</b>	<b>P63</b>	<b>BN63B6</b>	50-51
<b>0.18</b>	604 910	125 190	2.0 1.5	4.0 4.0	400 350	900 780	1200 1200	<b>V 0.25_</b> <b>V 0.25_</b>	<b>P63</b> <b>P63</b>	<b>BN71A6R</b> <b>BN63B4</b>	50-51 50-51
<b>0.25</b>	663 910 1000 1820	125 190 190 380	3.0 1.8 2.0 1.0	8.0 4.0 5.0 2.6	430 350 370 300	1100 780 970 620	1800 1200 1700 1060	<b>V 0.5_</b> <b>V 0.25_</b> <b>V 0.5_</b> <b>V 0.25_</b>	<b>P71</b> <b>P63</b> <b>P71</b> <b>P63</b>	<b>BN71B6</b> <b>BN63C4</b> <b>BN71A4</b> <b>BN63B2</b>	54-55 50-51 54-55 50-51
<b>0.37</b>	663 1000 1820	125 190 380	4.0 3.0 1.5	8.0 8.0 4.0	430 370 300	1100 970 620	1800 1700 1060	<b>V 0.5_</b> <b>V 0.5_</b> <b>V 0.25_</b>	<b>P71</b> <b>P71</b> <b>P63</b>	<b>BN71C6</b> <b>BN71B4</b> <b>BN63C2</b>	54-55 54-55 50-51
<b>0.55</b>	663 663 1000 1000 2000	125 125 190 190 380	6.0 6.0 4.5 4.5 2.0	8.0 16.0 8.0 12.0 5.0	— 750 — 650 520	960 1530 840 1330 750	1670 2680 1460 2330 1350	<b>V 0.5_</b> <b>V 1_</b> <b>V 0.5_</b> <b>V 1_</b> <b>V 0.5_</b>	<b>P80</b> <b>P80</b> <b>P80</b> <b>P80</b> <b>P71</b>	<b>BN80B6</b> <b>BN80B6</b> <b>BN80A4</b> <b>BN80A4</b> <b>BN71B2</b>	54-55 58-59 54-55 58-59 54-55
<b>0.75</b>	663 1000 1000 2000	125 190 190 380	8.0 6.0 6.0 3.0	16.0 16.0 8.0 8.0	750 650 — 520	1530 1330 840 750	2680 2330 1460 1350	<b>V 1_</b> <b>V 1_</b> <b>V 0.5_</b> <b>V 0.5_</b>	<b>P80</b> <b>P80</b> <b>P80</b> <b>P71</b>	<b>BN80C6</b> <b>BN80B4</b> <b>BN80B4</b> <b>BN71C2</b>	58-59 58-59 54-55 54-55
<b>1.1</b>	596 663 900 1000 2000 2000	125 125 190 190 380 380	12.0 12.0 9.1 9.0 4.5 4.5	16.0 32 16.0 24 8.0 12.0	— 1240 — 1080 — 870	1580 2030 1380 1770 670 1050	2660 3530 2320 3070 1160 1850	<b>V 1_</b> <b>V 2_</b> <b>V 1_</b> <b>V 2_</b> <b>V 0.5_</b> <b>V 1_</b>	<b>P90</b> <b>P90</b> <b>P90</b> <b>P90</b> <b>P80</b> <b>P80</b>	<b>BN90L6</b> <b>BN90L6</b> <b>BN90S4</b> <b>BN90S4</b> <b>BN80B2</b> <b>BN80B2</b>	58-59 62-63 58-59 62-63 54-55 58-59
<b>1.5</b>	663 900 1000 2000 2000	125 190 190 380 380	16.0 12.0 12.0 6.0 6.0	35 16.0 32 8.0 16.0	1240 — 1080 — 870	2030 1380 1770 370 1050	3530 2320 3070 1160 1850	<b>V 2_</b> <b>V 1_</b> <b>V 2_</b> <b>V 0.5_</b> <b>V 1_</b>	<b>P90</b> <b>P90</b> <b>P90</b> <b>P80</b> <b>P80</b>	<b>BN100LA6R</b> <b>BN90LA4</b> <b>BN90LA4</b> <b>BN80C2</b> <b>BN80C2</b>	62-63 58-59 62-63 54-55 58-59
<b>1.8</b>	1000	190	14.0	35	1080	1770	3070	<b>V 2_</b>	<b>P90</b>	<b>BN90LB4</b>	62-63
<b>2.2</b>	663 1000	125 190	24 16.0	56 40	2220 1930	3220 2790	5600 4860	<b>V 3_</b> <b>V 3_</b>	<b>P112</b> <b>P100</b>	<b>BN112M6</b> <b>BN100LA4</b>	66-67 66-67
<b>3.0</b>	1000	190	24	56	1930	2790	4860	<b>V 3_</b>	<b>P100</b>	<b>BN100LB4</b>	66-67
<b>4.0</b>	663 1000	125 190	43 32	86 72	2640 1930	4020 2790	7000 4860	<b>V 10_</b> <b>V 5.5_</b>	<b>P132</b> <b>P112</b>	<b>BN132MA6</b> <b>BN112M4</b>	74-75 70-71
<b>5.5</b>	663 1000	125 190	63 43	116 86	2640 2300	4020 3500	7000 6080	<b>V 10_</b> <b>V 10_</b>	<b>P132</b> <b>P132</b>	<b>BN132MB6</b> <b>BN132S4</b>	74-75 74-75
<b>7.5</b>	1000	190	58	116	2300	3500	6080	<b>V 10_</b>	<b>P132</b>	<b>BN132MA4</b>	74-75
<b>9.2</b>	1000	190	72	144	2300	3500	6080	<b>V 10_</b>	<b>P132</b>	<b>BN132MB4</b>	74-75



## VD\_

P <sub>1</sub> (kW)	n <sub>2</sub>		M <sub>2</sub> Nm	M <sub>2max</sub> Nm	R <sub>n1</sub> N	R <sub>n2</sub> N	R <sub>n2max</sub> N			
	min <sup>-1</sup>	n <sub>2</sub> ' min <sup>-1</sup>								
<b>0.25</b>	663	0	3.0	8.0	430	1100	1800	VD 0.5_ P71	BN71B6	78-79
	1000	0	2.0	5.0	370	970	1700	VD 0.5_ P71	BN71A4	78-79
<b>0.37</b>	663	0	4.0	8.0	430	1100	1800	VD 0.5_ P71	BN71C6	78-79
	1000	0	3.0	8.0	370	970	1700	VD 0.5_ P71	BN71B4	78-79
<b>0.55</b>	663	0	6.0	16.0	750	1530	2680	VD 1_ P80	BN80B6	78-79
	1000	0	4.5	12.0	650	1330	2330	VD 1_ P80	BN80A4	78-79
	2000	0	2.0	5.0	520	750	1350	VD 0.5_ P71	BN71B2	78-79
<b>0.75</b>	663	0	8.0	16.0	750	1530	2680	VD 1_ P80	BN80C6	78-79
	1000	0	6.0	16.0	650	1330	2330	VD 1_ P80	BN80B4	78-79
	2000	0	3.0	8.0	520	750	1350	VD 0.5_ P71	BN71C2	78-79
<b>1.1</b>	663	0	12.0	32	1240	2030	3530	VD 2_ P90	BN90L6	78-79
	1000	0	9.0	24	1080	1770	3070	VD 2_ P90	BN90S4	78-79
	2000	0	4.5	12.0	870	1050	1850	VD 1_ P80	BN80B2	78-79
<b>1.5</b>	663	0	16.0	35	1240	2030	3530	VD 2_ P90	BN100LA6R	78-79
	1000	0	12.0	32	1080	1770	3070	VD 2_ P90	BN90LA4	78-79
	2000	0	6.0	16.0	870	1050	1850	VD 1_ P80	BN80C2	78-79
<b>1.8</b>	1000	0	14.0	35	1080	1770	3070	VD 2_ P90	BN90LB4	78-79
<b>2.2</b>	663	0	24	56	2220	3220	5600	VD 3_ P112	BN112M6	78-79
	1000	0	16.0	40	1930	2790	4860	VD 3_ P100	BN100LA4	78-79
<b>3.0</b>	1000	0	24	56	1930	2790	4860	VD 3_ P100	BN100LB4	78-79
<b>4.0</b>	663	0	43	86	2640	4020	7000	VD 10_ P132	BN132MA6	78-79
	1000	0	32	72	1930	2790	4860	VD 5.5_ P112	BN112M4	78-79
<b>5.5</b>	663	0	63	116	2640	4020	7000	VD 10_ P132	BN132MB6	78-79
	1000	0	43	86	2300	3500	6080	VD 10_ P132	BN132S4	78-79
<b>7.5</b>	1000	0	58	116	2300	3500	6080	VD 10_ P132	BN132MA4	78-79
<b>9.2</b>	1000	0	72	144	2300	3500	6080	VD 10_ P132	BN132MB4	78-79

NB.  
Il numero di giri a cui è riferita la coppia  $M_{2max}$  è ricavabile dalle curve di coppia riportate nelle tabelle (C09...C11).

I carichi radiali in entrata al variatore (ingresso HS)  $R_{n1}$  e i carichi in uscita  $R_{n2}$  indicati in tabella sono da considerare applicati sulla mezzeria dell'albero. Per carichi la cui linea d'azione non coincide con la mezzeria dell'albero in esame, effettuare le verifiche riportate a pag. 8.

**AVVERTENZA:** Si sconsiglia l'utilizzo del variatore con velocità in ingresso inferiori a 300 min<sup>-1</sup>.

**NOTE.**  
*RPM for torque  $M_{2max}$  can be obtained from the torque diagrams shown in tables (C09...C11).*

*Radial loads applied at variator input (HS input)  $R_{n1}$  and output loads  $R_{n2}$  indicated in the table are referred to mid-point of shaft. Where loads are applied at any other position of shaft, follow procedure detailed on page 8 to verify compatibility.*

**WARNING:** The use of variator with input speeds lower than 300 rpm is NOT recommended.

**HINWEIS:**  
Die Drehzahl auf die sich das Drehmoment  $M_{2max}$  bezieht, ist den in der Tabelle (C09...C11) angegeben Drehmomentkurven zu entnehmen.

Die in der Tabelle angegebenen Radialkräfte am Antrieb des Verstellgetriebes (Antrieb HS)  $R_{n1}$  und die Lasten im Abtrieb  $R_{n2}$  sind als auf die Wellenmitte applizierte Kräfte zu kalkulieren. Für Kräfte, deren Wirkungslinie nicht mit der Mitte der zur Frage stehenden Welle übereinstimmt, sind die auf Seite 8 angeführten Kontrollen vorzunehmen.

**HINWEIS:** Von einem Einsatz des Verstellgetriebes mit einer Antriebsgeschwindigkeit unter 300 min<sup>-1</sup> wird abgeraten.

NB.  
*On peut obtenir le nombre des tours, auquel le couple  $M_{2max}$  se réfère, grâce aux courbes de couple indiquées sur le tableau (C09...C11).*

*Il faut considérer les charges radiales en entrée sur le variateur (entrée HS)  $R_{n1}$  et les charges en sortie  $R_{n2}$  indiquées sur le tableau comme appliquées au milieu de l'arbre. Pour les charges dont la ligne d'action ne coïncide pas avec le milieu de l'arbre concerné, effectuer les vérifications indiquées à page 8.*

**N.B. :** Il n'est pas conseillé d'utiliser le variateur avec une vitesse en entrée inférieure à 300 min<sup>-1</sup>.

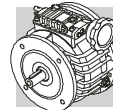

Le tabelle seguenti riportano i diagrammi di coppia dei motovariatori V e VD.

The tables below show the torque diagrams for motovariators V and VD.

Die nachstehenden Tabellen geben die Diagramme der Drehmomente an den Verstellgetrieben V und V\_D wieder.

Les tableaux suivants indiquent les diagrammes de couple des motovariateurs V et VD.

Per facilitarne la comprensione riportiamo un esempio con alcune indicazioni sui dati riportati.

An example diagram reporting corresponding data is provided for better clarity.

Zum leichteren Verständnis, führen wir ein Beispiel unter Grundlage der angegebenen Daten auf.

Par soucis de clarté voici un exemple avec des indications sur les données énoncées.

Tipo e ingresso variatore  
Variator type and input  
Typ und Antrieb des  
Verstellgetriebemotor  
Type et entrée du variateur

<b>V 0.5_P71</b>		T1	T2
$n_1 = 2800 \text{ min}^{-1}$	$M_2 =$	3.0 - 8.0 Nm	2.0 - 5.0 Nm
	$P_1 =$	0.75 kW	0.55 kW

Velocità in entrata al motovariatore  
Motovariator input speed  
Geschwindigkeit im Antrieb am  
Verstellgetriebemotor  
Vitesse en entrée sur le motovariateur

Coppia (Nm) in uscita al motovariatore  
Motovariator output torque (Nm)  
Drehmoment (Nm) im Abtrieb am  
Verstellgetriebemotor  
Couple (Nm) en sortie du  
motovariateur



Diagramma riferito a 0.75 kW  
Curve refers to 0.75 kW  
Diagramm bezüglich 0,75 kW  
Diagramme référé à 0,75 kW

Diagramma riferito a 0.55 kW  
Curve refers to 0.55 kW  
Diagramm bezüglich 0,55 kW  
Diagramme référé à 0,55 kW

Velocità in uscita al motovariatore  
Motovariator output speed  
Geschwindigkeit am Abtrieb des  
Verstellgetriebemotors  
Vitesse en sortie du motovariateur

Coppia (Nm) in uscita al motovariatore  
Motovariator output torque (Nm)  
Drehmoment (Nm) im Abtrieb am  
Verstellgetriebemotor  
Couple (Nm) en sortie du  
motovariateur

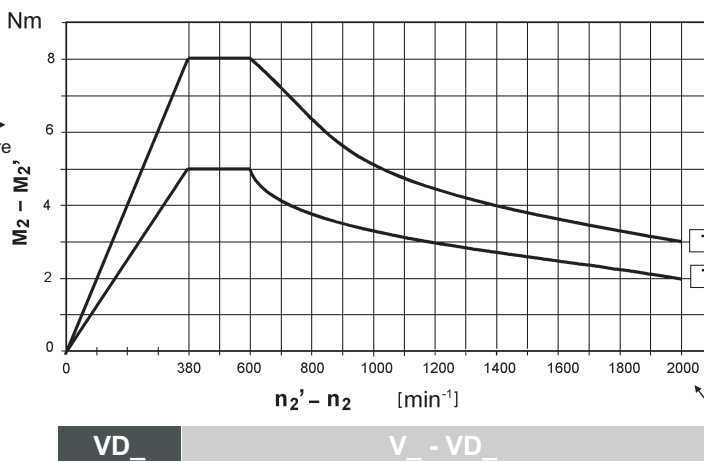
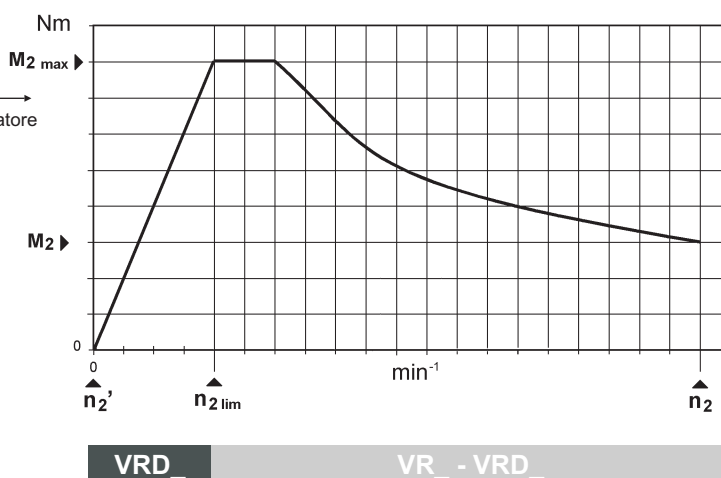

Velocità in uscita al motovariatore  
Motovariator output speed  
Geschwindigkeit am Abtrieb des  
Verstellgetriebemotors  
Vitesse en sortie du motovariateur

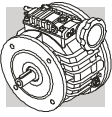

(C09)

**$n_1 = 2800$**

<b>V 0.25_P63</b> $n_1 = 2800 \text{ min}^{-1}$		T1	T2
	$M_2 =$	1.5 - 4.0 Nm	1.0 - 2.6 Nm
	$P_1 =$	0.37 kW	0.25 kW

<b>V 0.5_P71</b> $n_1 = 2800 \text{ min}^{-1}$		T1	T2
	$M_2 =$	3.0 - 8.0 Nm	2.0 - 5.0 Nm
	$P_1 =$	0.75 kW	0.55 kW

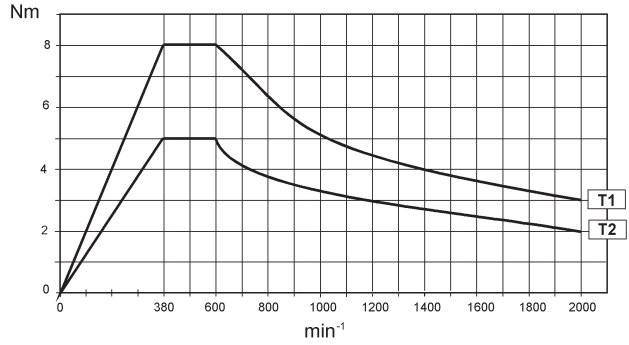
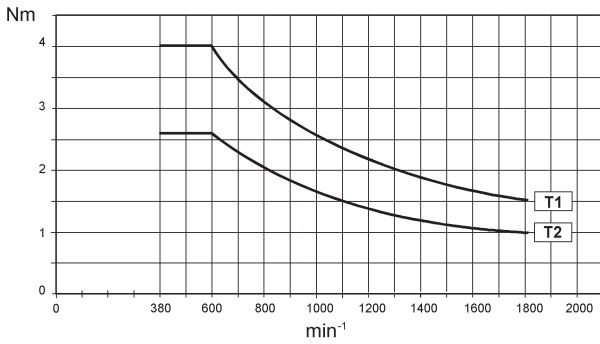

<b>V 0.5_P80</b> $n_1 = 2800 \text{ min}^{-1}$		T1	T2
	$M_2 =$	6.0 - 8.0 Nm	4.5 - 8.0 Nm
	$P_1 =$	1.5 kW	1.1 kW

<b>V 1_P80</b> $n_1 = 2800 \text{ min}^{-1}$		T1	T2
	$M_2 =$	6.0 - 16.0 Nm	4.5 - 12.0 Nm
	$P_1 =$	1.5 kW	1.1 kW

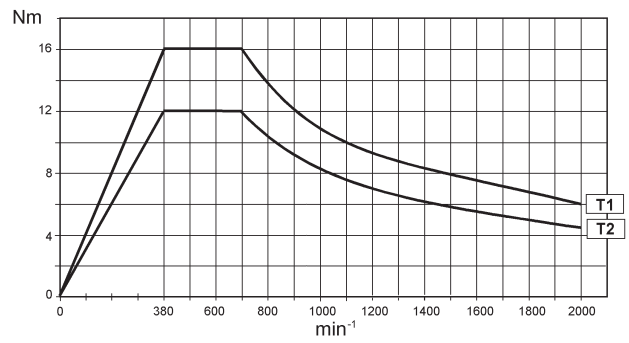
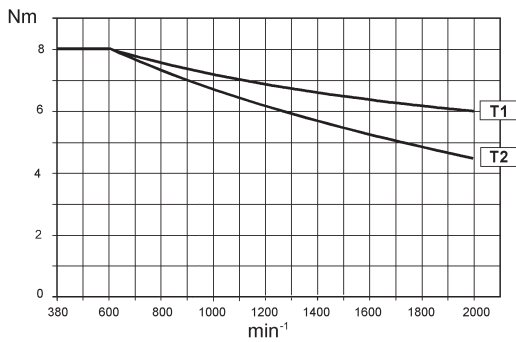

(C10a)

**$n_1 = 1400$**

<b>V 0.25_P63</b> $n_1 = 1400 \text{ min}^{-1}$		T1	T2
	$M_2 =$	1.8 - 4.0 Nm	1.5 - 4.0 Nm
	$P_1 =$	0.25 kW	0.18 kW

<b>V 0.5_P71</b> $n_1 = 1400 \text{ min}^{-1}$		T1	T2
	$M_2 =$	3.0 - 8.0 Nm	2.0 - 5.0 Nm
	$P_1 =$	0.37 kW	0.25 kW

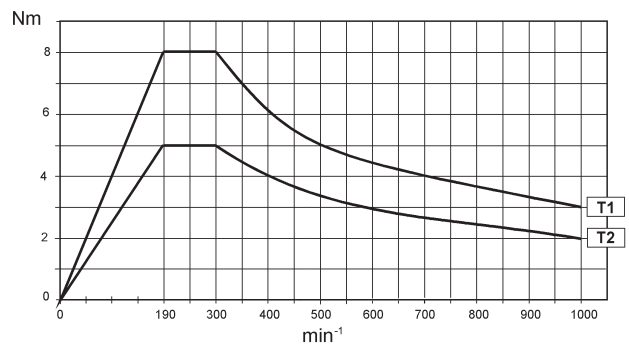
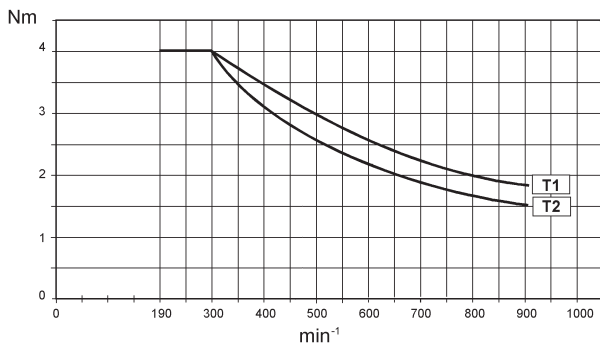

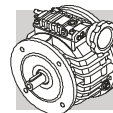

(C10b)

**$n_1 = 1400$**

V 0.5_P80	T1		T2
	$M_2=$	6.0 - 8.0 Nm	4.5 - 8.0 Nm
$n_1 = 1400 \text{ min}^{-1}$	$P_1=$	0.75 kW	0.55 kW

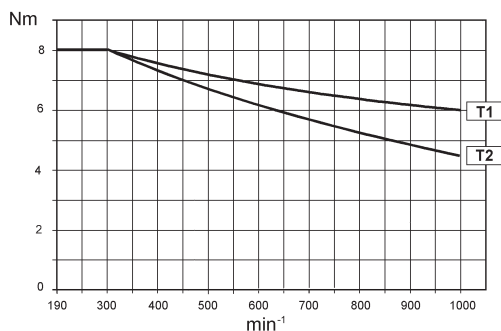

V 3_P100	T1		T2
	$M_2=$	24 - 56 Nm	16.0 - 40 Nm
$n_1 = 1400 \text{ min}^{-1}$	$P_1=$	3.0 kW	2.2 kW

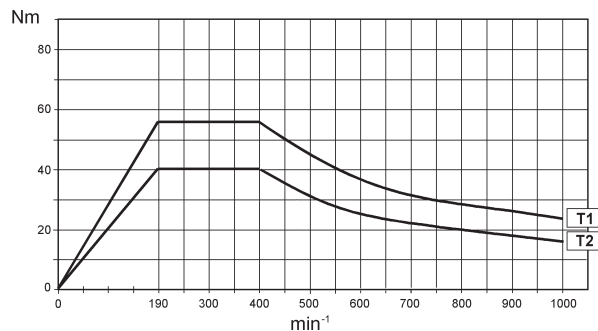

V 1_P80	T1		T2
	$M_2=$	6.0 - 16.0 Nm	4.5 - 12.0 Nm
$n_1 = 1400 \text{ min}^{-1}$	$P_1=$	0.75 kW	0.55 kW

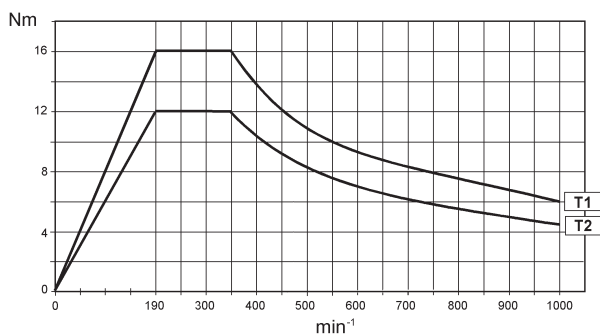

V 5.5_P112	T1	
	$M_2=$	32 - 72 Nm
$n_1 = 1400 \text{ min}^{-1}$	$P_1=$	4.0 kW

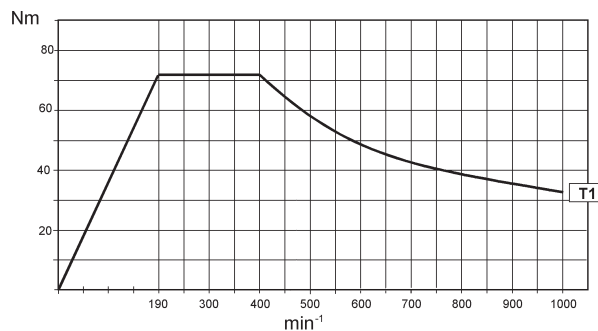

V 1_P90	T1		T2
	$M_2=$	12.0 - 16.0 Nm	9.1 - 16.0 Nm
$n_1 = 1400 \text{ min}^{-1}$	$P_1=$	1.1 kW	1.1 kW

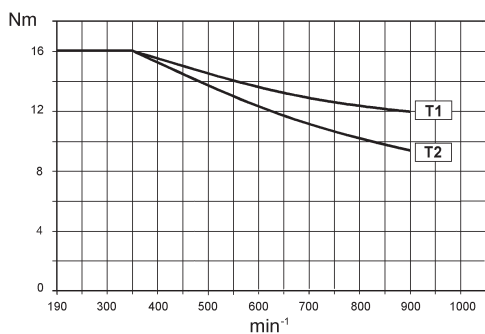

V 10_P132	T1		T2	T3
	$M_2=$	72 - 144 Nm	58 - 116 Nm	43 - 86 Nm
$n_1 = 1400 \text{ min}^{-1}$	$P_1=$	9.2 kW	7.5 kW	5.5 kW

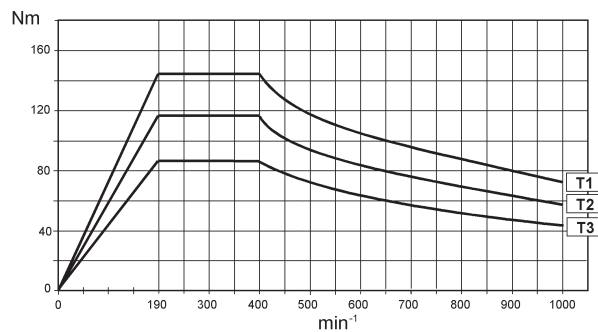

V 2_P90	T1		T2	T3
	$M_2=$	14.0 - 35 Nm	12.0 - 32 Nm	9.0 - 24 Nm
$n_1 = 1400 \text{ min}^{-1}$	$P_1=$	1.8 kW	1.5 kW	1.1 kW

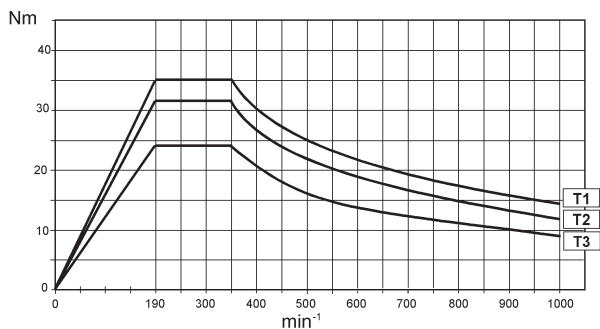

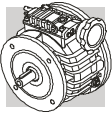

(C11)

**$n_1 = 900$**

<b>V 0.25_P63</b> $n_1 = 900 \text{ min}^{-1}$		T1	T2
	M <sub>2</sub>	2.0 - 4.0 Nm	1.4 - 3.7 Nm
	P <sub>1</sub>	0.18 kW	0.12 kW

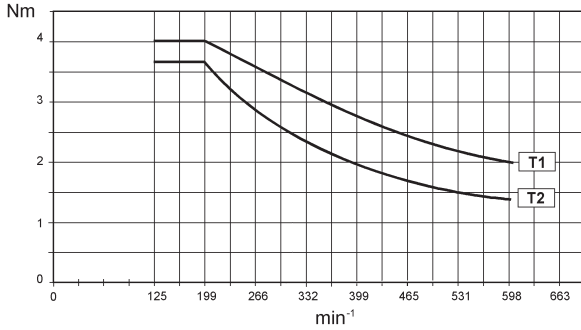

<b>V 1_P90</b> $n_1 = 900 \text{ min}^{-1}$		T1	
	M <sub>2</sub>	12.0 - 16.0 Nm	
	P <sub>1</sub>	1.1 kW	

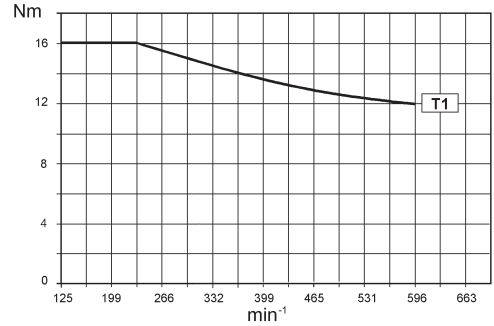

<b>V 0.5_P71</b> $n_1 = 900 \text{ min}^{-1}$		T1	T2
	M <sub>2</sub>	4.0 - 8.0 Nm	3.0 - 8.0 Nm
	P <sub>1</sub>	0.37 kW	0.25 kW

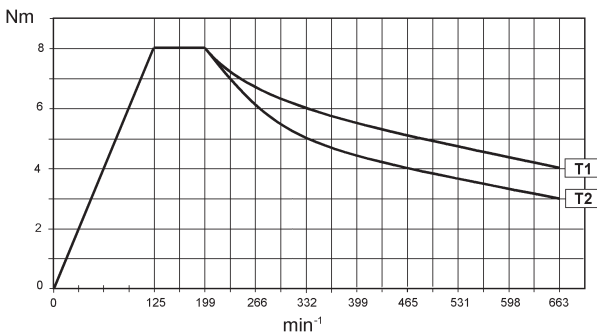

<b>V 2_P90</b> $n_1 = 900 \text{ min}^{-1}$		T1	T2
	M <sub>2</sub>	16.0 - 35 Nm	12.0 - 32 Nm
	P <sub>1</sub>	1.5 kW	1.1 kW

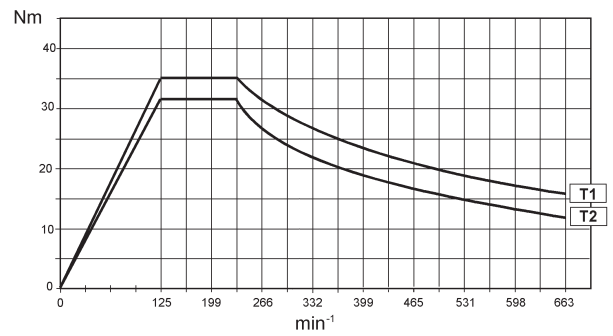

<b>V 0.5_P80</b> $n_1 = 900 \text{ min}^{-1}$		T1	
	M <sub>2</sub>	6.0 - 8.0 Nm	
	P <sub>1</sub>	0.55 kW	

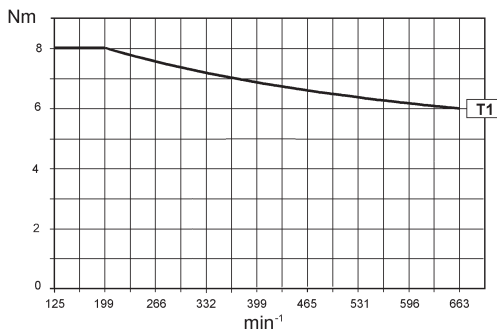

<b>V 3_P112</b> $n_1 = 900 \text{ min}^{-1}$		T1	
	M <sub>2</sub>	24 - 56 Nm	
	P <sub>1</sub>	2.2 kW	

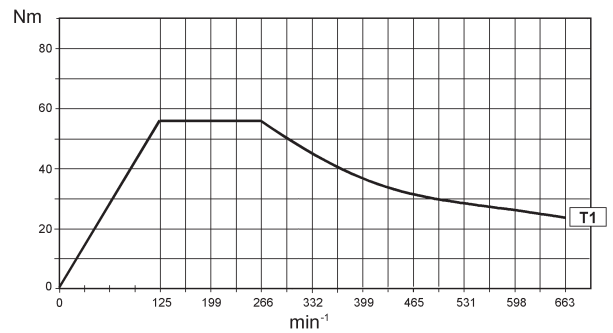

<b>V 1_P80</b> $n_1 = 900 \text{ min}^{-1}$		T1	T2
	M <sub>2</sub>	8.0 - 16.0 Nm	6.0 - 16.0 Nm
	P <sub>1</sub>	0.75 kW	0.55 kW

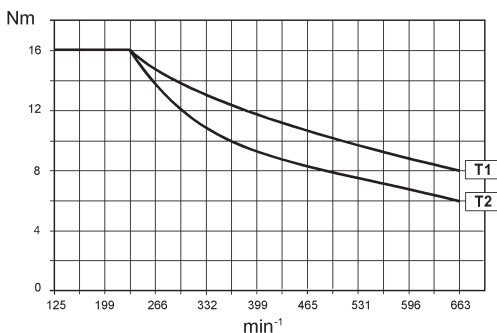

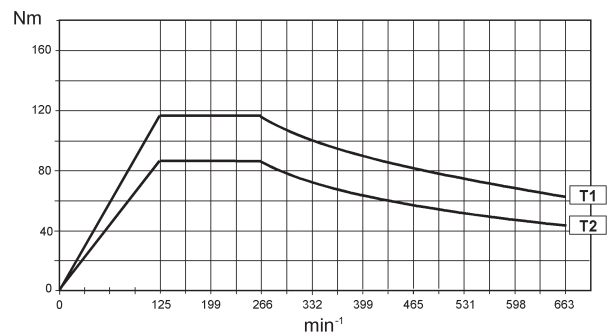

<b>V 10_P132</b> $n_1 = 900 \text{ min}^{-1}$		T1	T2
	M <sub>2</sub>	63 - 116 Nm	43 - 86 Nm
	P <sub>1</sub>	5.5 kW	4.0 kW



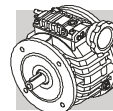



## VR

P <sub>1</sub> (kW)	n <sub>2</sub>	n <sub>2</sub> '	M <sub>2</sub>	M <sub>2</sub> '	R <sub>n1</sub>	R <sub>n2</sub>	R <sub>n2</sub> '	i			
	min <sup>-1</sup>	min <sup>-1</sup>	Nm	Nm	N	N	N				
<b>0.12</b>	96	19.8	8.6	22	400	1550	2600	6.3	VR 0.25_P63	BN63B6	52-53
	156	32	5.3	13.6	400	1300	2200	3.9	VR 0.25_P63	BN63B6	52-53
	244	50	3.4	8.7	400	1150	1900	2.5	VR 0.25_P63	BN63B6	52-53
<b>0.18</b>	96	19.8	12.3	24	400	1500	2600	6.3	VR 0.25_P63	BN71A6R	52-53
	144	30.2	9.3	24	350	1350	2250	6.3	VR 0.25_P63	BN63B4	52-53
	156	49	5.7	14.7	350	1300	1900	3.9	VR 0.25_P63	BN63B4	52-53
	235	32	7.6	14.7	400	1100	2200	3.9	VR 0.25_P63	BN71A6R	52-53
	244	50	4.9	9.4	400	1000	1900	2.5	VR 0.25_P63	BN71A6R	52-53
	367	77	3.6	9.4	350	950	1650	2.5	VR 0.25_P63	BN63B4	52-53
<b>0.25</b>	105	19.8	18.5	40	430	1500	2550	6.3	VR 0.5_P71	BN71B6	56-57
	144	30.2	11.1	24	350	1350	2250	6.3	VR 0.25_P63	BN63C4	52-53
	159	30	12.3	30	370	1300	2250	6.3	VR 0.5_P71	BN71A4	56-57
	171	32	11.4	29	430	1250	2200	3.9	VR 0.5_P71	BN71B6	56-57
	235	49	6.8	14.7	350	1150	1900	3.9	VR 0.25_P63	BN63C4	52-53
	258	49	7.6	18.4	370	1100	1900	3.9	VR 0.5_P71	BN71A4	56-57
	267	50	7.3	18.8	430	1100	1900	2.5	VR 0.5_P71	BN71B6	56-57
	289	60	6.2	15.6	300	1000	1800	6.3	VR 0.25_P63	BN63B2	52-53
	367	77	4.4	9.4	350	950	1650	2.5	VR 0.25_P63	BN63C4	52-53
	403	77	4.9	11.8	370	950	1650	2.5	VR 0.5_P71	BN71A4	56-57
	470	98	3.8	9.6	300	900	1550	3.9	VR 0.25_P63	BN63B2	52-53
	734	153	2.4	6.1	300	790	1300	2.5	VR 0.25_P63	BN63B2	52-53
<b>0.37</b>	105	19.8	25	40	430	1450	2550	6.3	VR 0.5_P71	BN71C6	56-57
	159	30	18.5	40	370	1300	2200	6.3	VR 0.5_P71	BN71B4	56-57
	171	32	15.2	29	430	1250	2200	3.9	VR 0.5_P71	BN71C6	56-57
	258	49	11.4	29	370	1100	1900	3.9	VR 0.5_P71	BN71B4	56-57
	267	50	9.7	18.8	430	1100	1900	2.5	VR 0.5_P71	BN71C6	56-57
	289	60	9.3	24	300	1050	1800	6.3	VR 0.25_P63	BN63C2	52-53
	403	77	7.3	18.8	370	950	1650	2.5	VR 0.5_P71	BN71B4	56-57
	470	98	5.7	14.7	300	900	1500	3.9	VR 0.25_P63	BN63C2	52-53
734	153	3.6	9.4	300	800	1300	2.5	VR 0.25_P63	BN63C2	52-53	
<b>0.55</b>	103	19.5	38	70	750	1350	2300	6.4	VR 1_P80	BN80B6	60-61
	156	29.6	28	65	650	1150	1970	6.4	VR 1_P80	BN80A4	60-61
	168	32	23	60	750	1150	1950	3.9	VR 1_P80	BN80B6	60-61
	254	48	17.4	45	650	1000	1700	3.9	VR 1_P80	BN80A4	60-61
	274	52	14.2	37	750	990	1650	2.4	VR 1_P80	BN80B6	60-61
	317	60	12.3	30	520	1000	1750	6.3	VR 0.5_P71	BN71B2	56-57
	413	79	10.7	28	650	850	1450	2.4	VR 1_P80	BN80A4	60-61
	517	98	7.6	18.4	520	900	1500	3.9	VR 0.5_P71	BN71B2	56-57
	806	153	4.9	11.8	520	750	1300	2.5	VR 0.5_P71	BN71B2	56-57
<b>0.75</b>	103	19.5	50	70	750	1250	2300	6.4	VR 1_P80	BN80C6	60-61
	156	29.6	28	65	650	1150	1970	6.4	VR 1_P80	BN80B4	60-61
	168	32	23	60	750	1150	1950	3.9	VR 1_P80	BN80C6	60-61
	254	48	23	60	650	990	1650	3.9	VR 1_P80	BN80B4	60-61
	274	52	19.0	37	750	980	1650	2.4	VR 1_P80	BN80C6	60-61
	317	60	18.5	40	520	1000	1750	6.3	VR 0.5_P71	BN71C2	56-57
	413	78	14.2	37	650	870	1450	2.4	VR 1_P80	BN80B4	60-61
	517	98	11.4	29	520	850	1500	3.9	VR 0.5_P71	BN71C2	56-57
	806	153	7.3	18.8	520	780	1300	2.5	VR 0.5_P71	BN71C2	56-57
<b>1.1</b>	101	19.0	77	150	1240	2600	4300	6.6	VR 2_P90	BN90L6	64-65
	152	28.9	58	140	1080	2400	3600	6.6	VR 2_P90	BN90S4	64-65
	163	31	48	123	1240	2300	3700	4.1	VR 2_P90	BN90L6	64-65
	246	47	36	93	1080	2000	3400	4.1	VR 2_P90	BN90S4	64-65
	280	53	28	72	1240	1950	3400	2.4	VR 2_P90	BN90L6	64-65
	312	59	28	60	870	900	1500	6.4	VR 1_P80	BN80B2	60-61
	422	80	21	54	1080	1950	2950	2.4	VR 2_P90	BN90S4	64-65
	508	96	17.4	45	870	800	1300	3.9	VR 1_P80	BN80B2	60-61
	826	157	10.7	28	870	680	1150	2.4	VR 1_P80	BN80B2	60-61
<b>1.5</b>	101	19.0	103	150	1240	2300	4300	6.6	VR 2_P90	BN100LA6R	64-65
	152	28.9	77	140	1080	2150	3600	6.6	VR 2_P90	BN90LA4	64-65
	163	31	64	135	1240	2200	3400	4.1	VR 2_P90	BN100LA6R	64-65
	246	47	48	123	1080	1950	3000	4.1	VR 2_P90	BN90LA4	64-65
	280	53	37	79	1240	1950	2950	2.4	VR 2_P90	BN100LA6R	64-65
	312	59	38	60	870	900	1500	6.4	VR 1_P80	BN80C2	60-61
	423	80	28	72	1080	1850	2850	2.4	VR 2_P90	BN90LA4	64-65
	508	96	23	55	870	780	1300	3.9	VR 1_P80	BN80C2	60-61
	826	157	14	37	870	680	1150	2.4	VR 1_P80	BN80C2	60-61
<b>1.8</b>	152	28.9	90	140	1080	2000	3600	6.6	VR 2_P90	BN90LB4	64-65
	246	47	56	120	1080	1900	3000	4.1	VR 2_P90	BN90LB4	64-65
	422	80	33	79	1080	1700	2750	2.4	VR 2_P90	BN90LB4	64-65
<b>2.2</b>	104	19.5	151	300*	—	—	—	6.4	VR 3_P112	BN112M6	68-69
	156	29.7	100	243	—	—	—	6.4	VR 3_P100	BN100LA4	68-69
	169	32	92	209	—	—	—	3.9	VR 3_P112	BN112M6	68-69
	254	48	62	149	—	—	—	3.9	VR 3_P100	BN100LA4	68-69
	281	53	56	126	—	—	—	2.4	VR 3_P112	BN112M6	68-69
	424	81	37	90	—	—	—	2.4	VR 3_P100	BN100LA4	68-69

\* Coppia massima ammissibile



\* Max. torque transmissible

\* Max. Drehmoment

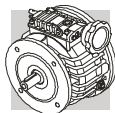
\* Couple maxi transmissible



## VR\_

P <sub>1</sub> (kW)	n <sub>2</sub> min <sup>-1</sup>	n <sub>2</sub> ' min <sup>-1</sup>	M <sub>2</sub> Nm	M <sub>2</sub> ' Nm	R <sub>n1</sub> N	R <sub>n2</sub> N	R <sub>n2</sub> ' N	i		IEC 		
<b>3.0</b>	156	29.7	151	280*	—	—	—	6.4	VR 3_	P100	BN100LB4	68-69
	254	48	92	209	—	—	—	3.9	VR 3_	P100	BN100LA4	68-69
	424	81	56	126	—	—	—	2.4	VR 3_	P100	BN100LA4	68-69
<b>4.0</b>	105	19.8	259	504	—	—	—	6.3	VR 10_	P132	BN132MA6	76-77
	156	29.7	201	280*	—	—	—	6.4	VR 5.5_	P112	BN112M4	72-73
	163	31	166	326	—	—	—	4.1	VR 10_	P132	BN132MA6	76-77
	254	48	123	250*	—	—	—	3.9	VR 5.5_	P112	BN112M4	72-73
	280	53	97	190	—	—	—	2.4	VR 10_	P132	BN132MA6	76-77
	349	66	80	152	—	—	—	1.9	VR 10_	P132	BN132MA6	76-77
<b>5.5</b>	424	81	74	161	—	—	—	2.4	VR 5.5_	P112	BN112M4	72-73
	105	19.8	377	680*	—	—	—	6.3	VR 10_	P132	BN132MB6	76-77
	158	30	266	516	—	—	—	6.3	VR 10_	P132	BN132S4	76-77
	163	31	244	439	—	—	—	4.1	VR 10_	P132	BN132MB6	76-77
	246	47	166	326	—	—	—	4.1	VR 10_	P132	BN132S4	76-77
	280	53	142	256	—	—	—	2.4	VR 10_	P132	BN132MB6	76-77
	349	66	113	205	—	—	—	1.9	VR 10_	P132	BN132MB6	76-77
	422	80	97	190	—	—	—	2.4	VR 10_	P132	BN132S4	76-77
	526	100	80	152	—	—	—	1.9	VR 10_	P132	BN132S4	76-77
<b>7.5</b>	158	30	348	680*	—	—	—	6.3	VR 10_	P132	BN132MA4	76-77
	246	47	224	439	—	—	—	4.1	VR 10_	P132	BN132MA4	76-77
	422	80	131	256	—	—	—	2.4	VR 10_	P132	BN132MA4	76-77
	526	100	105	205	—	—	—	1.9	VR 10_	P132	BN132MA4	76-77
<b>9.2</b>	158	30	431	680*	—	—	—	6.3	VR 10_	P132	BN132MB4	76-77
	246	47	278	540*	—	—	—	4.1	VR 10_	P132	BN132MB4	76-77
	422	80	162	317	—	—	—	2.4	VR 10_	P132	BN132MB4	76-77
	526	100	130	254	—	—	—	1.9	VR 10_	P132	BN132MB4	76-77

\* Coppia massima ammissibile

\* Max. torque transmissible

\* Max. Drehmoment

\* Couple maxi transmissible

NB.: I carichi radiali in entrata al variatore (ingresso HS) R<sub>n1</sub> e i carichi in uscita R<sub>n2</sub> indicati in tabella sono da considerare applicati sulla mezzeria dell'albero. Per carichi la cui linea d'azione non coincide con la mezzeria dell'albero in esame, effettuare le verifiche riportate a pag. 8.

NOTE.: Radial loads applied at variator input (HS input) R<sub>n1</sub> and output loads R<sub>n2</sub> indicated in the table are referred to mid-point of shaft. Where loads are applied at any other position of shaft, follow procedure detailed on page 8 to verify compatibility.

HINWEIS: alle angegebenen Radialkräfte am Antrieb des Verstellgetriebes (Antrieb HS) R<sub>n1</sub> und die Lasten im Abtrieb R<sub>n2</sub> sind als auf die Wellenmitte applizierte Kräfte zu kalkulieren. Für Kräfte, deren Wirkungslinie nicht mit der Mitte der zur Frage stehenden Welle übereinstimmt, sind die auf Seite 8 angeführten Kontrollen vorzunehmen.

NB.: Il faut considérer les charges radiales en entrée sur le variateur (entrée HS) R<sub>n1</sub> et les charges en sortie R<sub>n2</sub> indiquées sur le tableau comme appliquées au milieu de l'arbre. Pour les charges dont la ligne d'action ne coïncide pas avec le milieu de l'arbre concerné, effectuer les vérifications indiquées à page 8.



**AVVERTENZA:** Si sconsiglia l'utilizzo del variatore con velocità in ingresso inferiori a 300 min<sup>-1</sup>.

**WARNING:** The use of variator with input speeds lower than 300 rpm is NOT recommended.

**HINWEIS:** Von einem Einsatz des Verstellgetriebes mit einer Antriebsgeschwindigkeit unter 300 min<sup>-1</sup> wird abgeraten.



**N.B.:** Il n'est pas conseillé d'utiliser le variateur avec une vitesse en entrée inférieure à 300 min<sup>-1</sup>.

## VRD\_

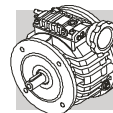
P <sub>1</sub> (kW)	n <sub>2</sub> min <sup>-1</sup>	n <sub>2</sub> lim min <sup>-1</sup>	n <sub>2</sub> ' min <sup>-1</sup>	M <sub>2</sub> Nm	M <sub>2</sub> max Nm	R <sub>n1</sub> N	R <sub>n2</sub> N	R <sub>n2</sub> max N	i		IEC 		
<b>0.25</b>	105	19.8	0	18.5	40	430	1500	2550	6.3	VRD 0.5_	P71	BN71B6	80-81
	159	30	0	12.3	30	370	1300	2250	6.3	VRD 0.5_	P71	BN71A4	80-81
	171	32	0	11.4	29	430	1250	2200	3.9	VRD 0.5_	P71	BN71B6	80-81
	258	49	0	7.6	18.4	370	1100	1900	3.9	VRD 0.5_	P71	BN71A4	80-81
	267	50	0	7.3	18.8	430	1100	1900	2.5	VRD 0.5_	P71	BN71B6	80-81
	289	60	0	6.2	15.6	300	1000	1800	6.3	VRD 0.25_	P63	BN63B2	80-81
	403	77	0	4.9	11.8	370	950	1650	2.5	VRD 0.5_	P71	BN71A4	80-81
	470	98	0	3.8	9.6	300	900	1550	3.9	VRD 0.25_	P63	BN63B2	80-81
<b>0.37</b>	734	153	0	2.4	6.1	300	790	1300	2.5	VRD 0.25_	P63	BN63B2	80-81
	105	19.8	0	25	40	430	1450	2550	6.3	VRD 0.5_	P71	BN71C6	80-81
	159	30	0	18.5	40	370	1300	2200	6.3	VRD 0.5_	P71	BN71B4	80-81
	171	32	0	15.2	29	430	1250	2200	3.9	VRD 0.5_	P71	BN71C6	80-81
	258	49	0	11.4	29	370	1100	1900	3.9	VRD 0.5_	P71	BN71B4	80-81
	267	50	0	9.7	18.8	430	1100	1900	2.5	VRD 0.5_	P71	BN71C6	80-81
	289	60	0	9.3	24	300	1050	1800	6.3	VRD 0.25_	P63	BN63C2	80-81
	403	77	0	7.3	18.8	370	950	1650	2.5	VRD 0.5_	P71	BN71B4	80-81
	470	98	0	5.7	14.7	300	900	1500	3.9	VRD 0.25_	P63	BN63C2	80-81
734	153	0	3.6	9.4	300	800	1300	2.5	VRD 0.25_	P63	BN63C2	80-81	



## VRD\_

P <sub>1</sub> (kW)	n <sub>2</sub>	n <sub>2</sub> lim	n <sub>2</sub> '	M <sub>2</sub>	M <sub>2</sub> max	R <sub>n1</sub>	R <sub>n2</sub>	R <sub>n2</sub> max	i				
	min <sup>-1</sup>	min <sup>-1</sup>	min <sup>-1</sup>	Nm	Nm	N	N	N					
<b>0.55</b>	103	19.5	0	38	70	750	1350	2300	6.4	VRD 1_	P80	BN80B6	80-81
	156	29.6	0	28	65	650	1150	1970	6.4	VRD 1_	P80	BN80A4	80-81
	168	32	0	23	60	750	1150	1950	3.9	VRD 1_	P80	BN80B6	80-81
	254	48	0	17.4	45	650	1000	1700	3.9	VRD 1_	P80	BN80A4	80-81
	274	52	0	14.2	37	750	990	1650	2.4	VRD 1_	P80	BN80B6	80-81
	317	60	0	12.3	30	520	1000	1750	6.3	VRD 0.5_	P71	BN71B2	80-81
	413	79	0	10.7	28	650	850	1450	2.4	VRD 1_	P80	BN80A4	80-81
	517	98	0	7.6	18.4	520	900	1500	3.9	VRD 0.5_	P71	BN71B2	80-81
806	153	0	4.9	11.8	520	750	1300	2.5	VRD 0.5_	P71	BN71B2	80-81	
<b>0.75</b>	103	19.5	0	50	70	750	1250	2300	6.4	VRD 1_	P80	BN80C6	80-81
	156	29.6	0	28	65	650	1150	1970	6.4	VRD 1_	P80	BN80B4	80-81
	168	32	0	23	60	750	1150	1950	3.9	VRD 1_	P80	BN80C6	80-81
	254	48	0	23	60	650	990	1650	3.9	VRD 1_	P80	BN80B4	80-81
	274	52	0	19.0	37	750	980	1650	2.4	VRD 1_	P80	BN80C6	80-81
	317	60	0	18.5	40	520	1000	1750	6.3	VRD 0.5_	P71	BN71C2	80-81
	413	78	0	14.2	37	650	870	1450	2.4	VRD 1_	P80	BN80B4	80-81
	517	98	0	11.4	29	520	850	1500	3.9	VRD 0.5_	P71	BN71C2	80-81
806	153	0	7.3	18.8	520	780	1300	2.5	VRD 0.5_	P71	BN71C2	80-81	
<b>1.1</b>	101	19.0	0	77	150	1240	2600	4300	6.6	VRD 2_	P90	BN90L6	80-81
	152	28.9	0	58	140	1080	2400	3600	6.6	VRD 2_	P90	BN90S4	80-81
	163	31	0	48	123	1240	2300	3700	4.1	VRD 2_	P90	BN90L6	80-81
	246	47	0	36	93	1080	2000	3400	4.1	VRD 2_	P90	BN90S4	80-81
	280	53	0	28	72	1240	1950	3400	2.4	VRD 2_	P90	BN90L6	80-81
	312	59	0	28	60	870	900	1500	6.4	VRD 1_	P80	BN80B2	80-81
	422	80	0	21	54	1080	1950	2950	2.4	VRD 2_	P90	BN90S4	80-81
	508	96	0	17.4	45	870	800	1300	3.9	VRD 1_	P80	BN80B2	80-81
826	157	0	10.7	28	870	680	1150	2.4	VRD 1_	P80	BN80B2	80-81	
<b>1.5</b>	101	19.0	0	103	150	1240	2300	4300	6.6	VRD 2_	P90	BN100LA6R	80-81
	152	28.9	0	77	140	1080	2150	3600	6.6	VRD 2_	P90	BN90LA4	80-81
	163	31	0	64	135	1240	2200	3400	4.1	VRD 2_	P90	BN100LA6R	80-81
	246	47	0	48	123	1080	1950	3000	4.1	VRD 2_	P90	BN90LA4	80-81
	280	53	0	37	79	1240	1950	2950	2.4	VRD 2_	P90	BN100LA6R	80-81
	312	59	0	38	60	870	900	1500	6.4	VRD 1_	P80	BN80C2	80-81
	423	80	0	28	72	1080	1850	2850	2.4	VRD 2_	P90	BN90LA4	80-81
	508	96	0	23	55	870	780	1300	3.9	VRD 1_	P80	BN80C2	80-81
826	157	0	14	37	870	680	1150	2.4	VRD 1_	P80	BN80C2	80-81	
<b>1.8</b>	152	28.9	0	90	140	1080	2000	3600	6.6	VRD 2_	P90	BN90LB4	80-81
	246	47	0	56	120	1080	1900	3000	4.1	VRD 2_	P90	BN90LB4	80-81
	422	80	0	33	79	1080	1700	2750	2.4	VRD 2_	P90	BN90LB4	80-81
<b>2.2</b>	104	19.5	0	151	300*	—	—	—	6.4	VRD 3_	P112	BN112M6	80-81
	156	29.7	0	100	243	—	—	—	6.4	VRD 3_	P100	BN100LA4	80-81
	169	32	0	92	209	—	—	—	3.9	VRD 3_	P112	BN112M6	80-81
	254	48	0	62	149	—	—	—	3.9	VRD 3_	P100	BN100LA4	80-81
	281	53	0	56	126	—	—	—	2.4	VRD 3_	P112	BN112M6	80-81
424	81	0	37	90	—	—	—	2.4	VRD 3_	P100	BN100LA4	80-81	
<b>3.0</b>	156	29.7	0	151	280*	—	—	—	6.4	VRD 3_	P100	BN100LB4	80-81
	254	48	0	92	209	—	—	—	3.9	VRD 3_	P100	BN100LA4	80-81
	424	81	0	56	126	—	—	—	2.4	VRD 3_	P100	BN100LA4	80-81
<b>4.0</b>	105	19.8	0	259	504	—	—	—	6.3	VRD 10_	P132	BN132MA6	80-81
	156	29.7	0	201	280*	—	—	—	6.4	VRD 5.5_	P112	BN132M4	80-81
	163	31	0	166	326	—	—	—	4.1	VRD 10_	P132	BN132MA6	80-81
	254	48	0	123	250*	—	—	—	3.9	VRD 5.5_	P112	BN132M4	80-81
	280	53	0	97	190	—	—	—	2.4	VRD 10_	P132	BN132MA6	80-81
	349	66	0	80	152	—	—	—	1.9	VRD 10_	P132	BN132MA6	80-81
424	81	0	74	161	—	—	—	2.4	VRD 5.5_	P112	BN132M4	80-81	
<b>5.5</b>	105	19.8	0	377	680*	—	—	—	6.3	VRD 10_	P132	BN132MB6	80-81
	158	30	0	266	516	—	—	—	6.3	VRD 10_	P132	BN132S4	80-81
	163	31	0	244	439	—	—	—	4.1	VRD 10_	P132	BN132MB6	80-81
	246	47	0	166	326	—	—	—	4.1	VRD 10_	P132	BN132S4	80-81
	280	53	0	142	256	—	—	—	2.4	VRD 10_	P132	BN132MB6	80-81
	349	66	0	113	205	—	—	—	1.9	VRD 10_	P132	BN132MB6	80-81
	422	80	0	97	190	—	—	—	2.4	VRD 10_	P132	BN132S4	80-81
526	100	0	80	152	—	—	—	1.9	VRD 10_	P132	BN132S4	80-81	
<b>7.5</b>	158	30	0	348	680*	—	—	—	6.3	VRD 10_	P132	BN132MA4	80-81
	246	47	0	224	439	—	—	—	4.1	VRD 10_	P132	BN132MA4	80-81
	422	80	0	131	256	—	—	—	2.4	VRD 10_	P132	BN132MA4	80-81
	526	100	0	105	205	—	—	—	1.9	VRD 10_	P132	BN132MA4	80-81
<b>9.2</b>	158	30	0	431	680*	—	—	—	6.3	VRD 10_	P132	BN132MB4	80-81
	246	47	0	278	540*	—	—	—	4.1	VRD 10_	P132	BN132MB4	80-81
	422	80	0	162	317	—	—	—	2.4	VRD 10_	P132	BN132MB4	80-81
	526	100	0	130	254	—	—	—	1.9	VRD 10_	P132	BN132MB4	80-81

\* Coppia massima ammissibile

\* Max. torque transmissible

\* Max. Drehmoment

\* Couple maxi transmissible

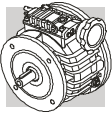

# V 0.25

## 18.9 - Dimensioni

## 18.9 - Dimensions

## 18.9 - Masse

## 18.9 - Dimensions

### V 0.25 F\_P63

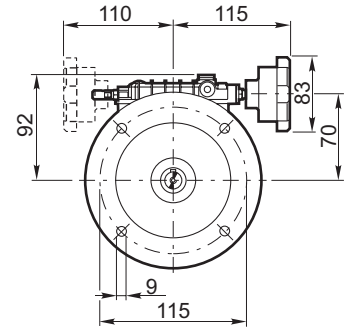
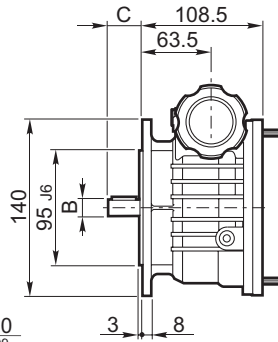
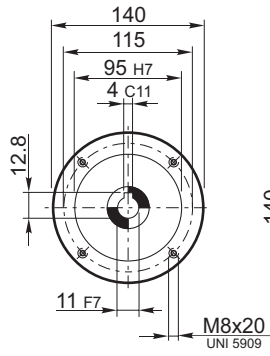

### V 0.25 UP\_P63

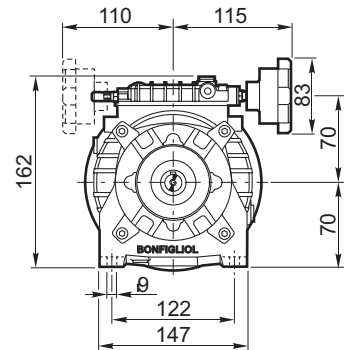
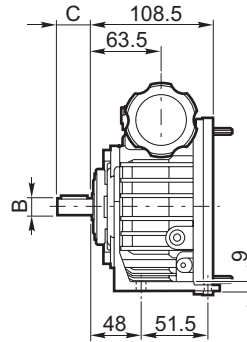
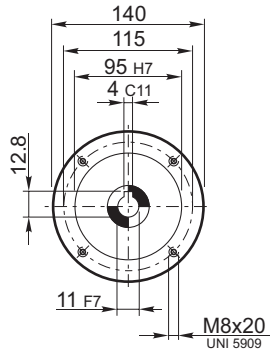

### V 0.25 UF\_P63

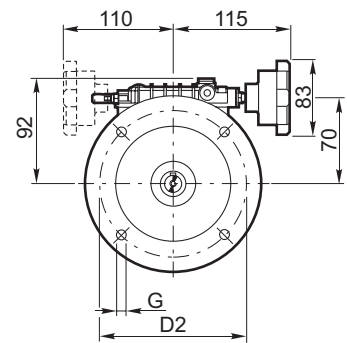
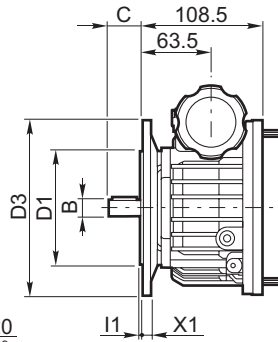
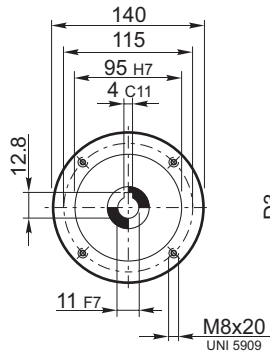

### V 0.25 UPF\_P63

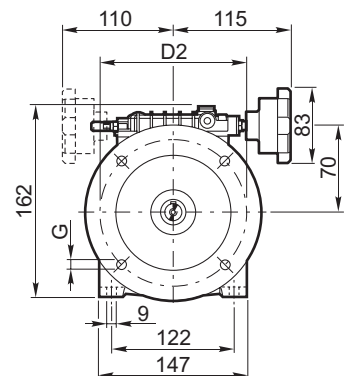
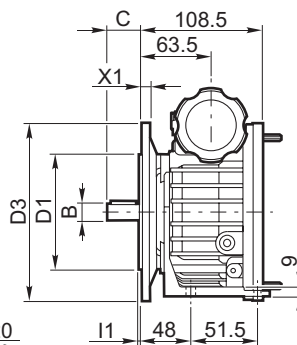
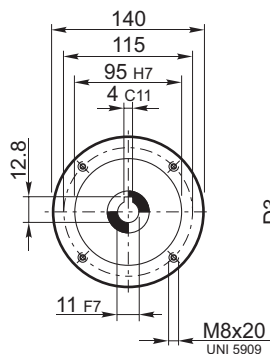

F-UP-UF-UPF	B j6	B1	B2	B3	B4	C	U
V 0.25_D11	11	12.5	4	2.5	18	23	M4
V 0.25_D14	14	16	5	2.5	25	30	M5

UF-UPF	D1 j6	D2	D3	G	I1	X1
V 0.25 UF63_	95	115	140	9	3	8
V 0.25 UF71_	110	130	160	9	3.5	8

V 0.25_P63	Kg			
	F	UP	UF	UPF
	4.5	4.9	5.0	5.1

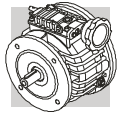

**V 0.25 F\_P63**

**V 0.25 UP\_P63**

**V 0.25 UF\_P63**

**V 0.25 UPF\_P63**

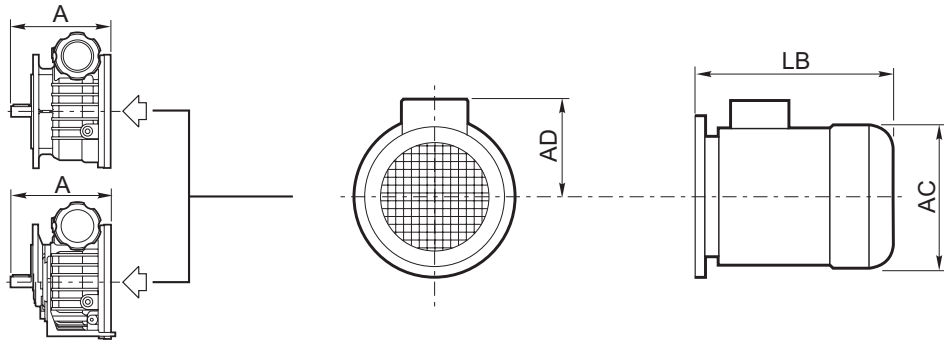

**BN**

**V 0.25 F\_**

**V 0.25 UP\_**

**V 0.25 UF\_**

**V 0.25 UPF\_**

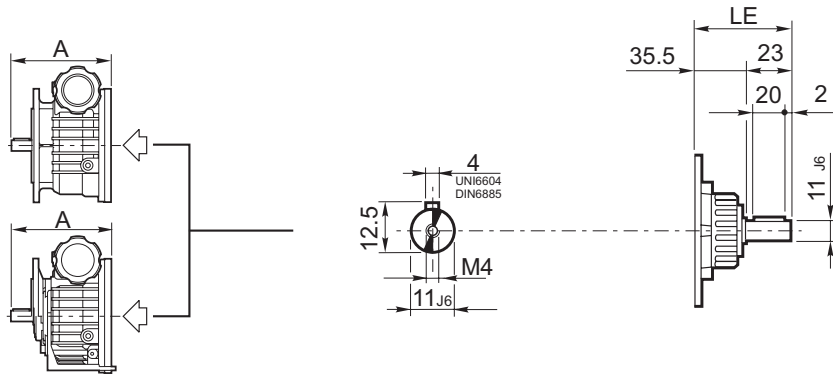

**HS**

**V 0.25 F\_**

**V 0.25 UP\_**

**V 0.25 UF\_**

**V 0.25 UPF\_**

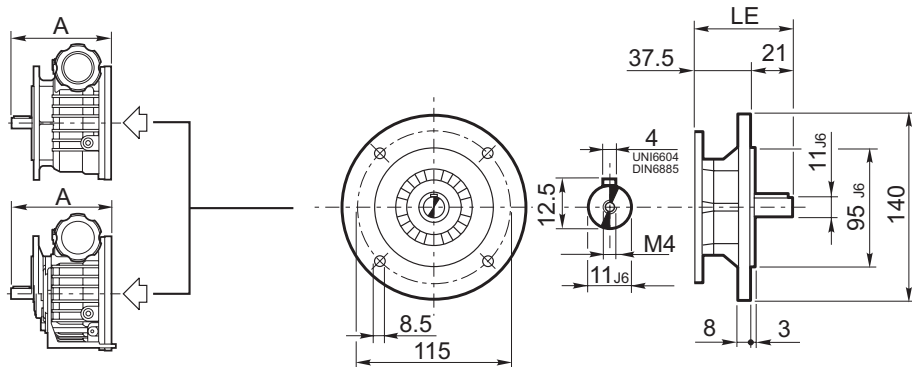

**HSF**

		AC	AD	LB	A+LB		Kg			
					D11	D14	F	UP	UF	UPF
V 0.25_P63	BN63_	121	95	184	315.5	322.5	8.4	8.8	8.9	9.0
	BN71R_	138	108	219	350.5	357.5	9.9	10.3	10.4	10.5

	LE	A+LE		LM	A+LM		Kg			
		D11	D14		D11	D14	F	UP	UF	UPF
V 0.25_HS	58.5	190	197	—	—	—	5.6	6.0	6.1	6.2
V 0.25_HSF	58.5	190	197	—	—	—	6.1	6.5	6.6	6.7

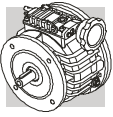

# VR 0.25

**VR 0.25 U\_P63**

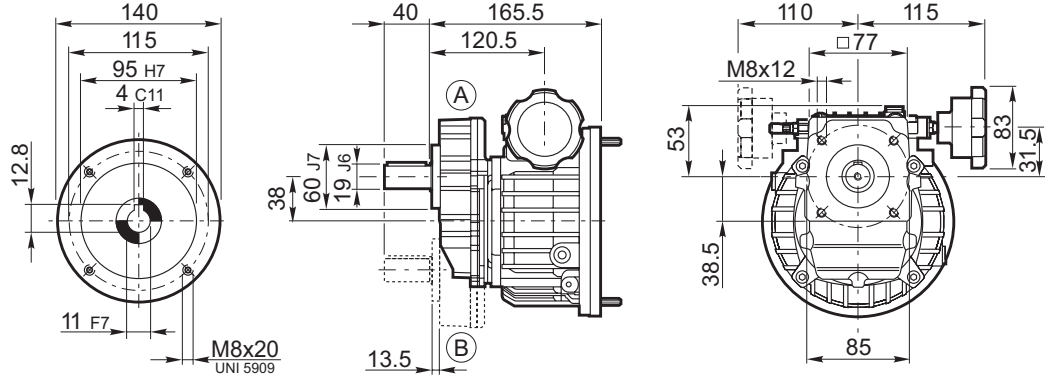

**VR 0.25 P\_P63**

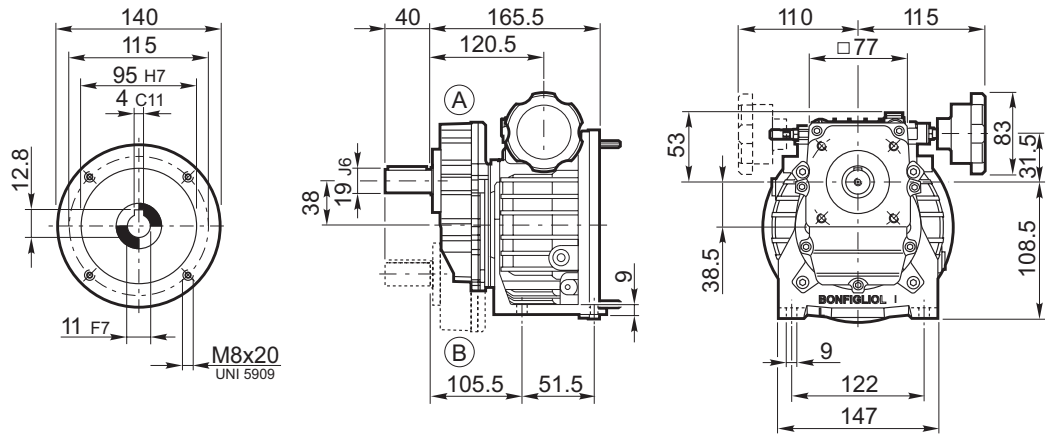

**VR 0.25 F\_P63**

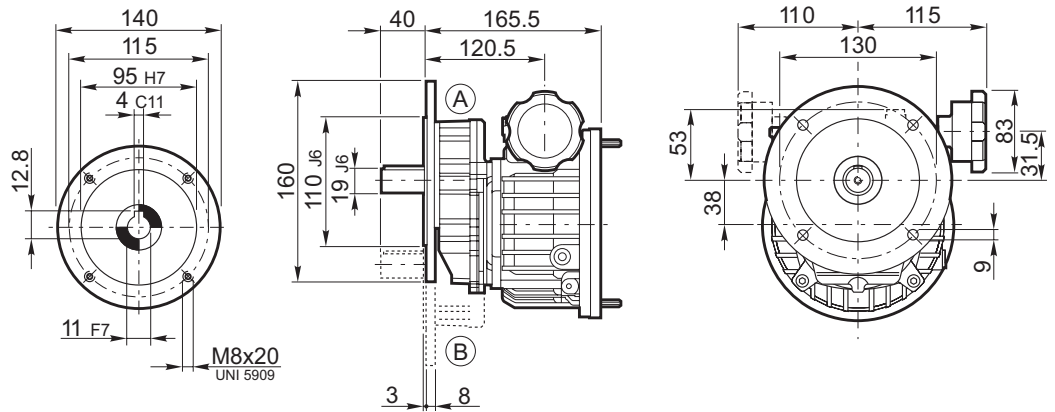

U-P-F	B j6	B1	B2	B3	B4	C	U
VR 0.25	19	21.5	6	3	35	40	M6

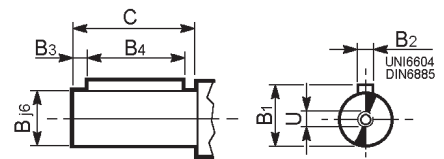

	Kg		
	F	UP	UPF
VR 0.25_P63	7.8	7.0	7.7

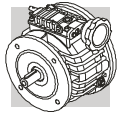

**VR 0.25 F\_P63**

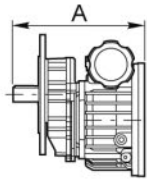

**VR 0.25 U\_P63**

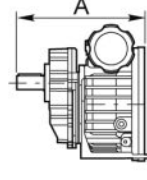

**VR 0.25 P\_P63**

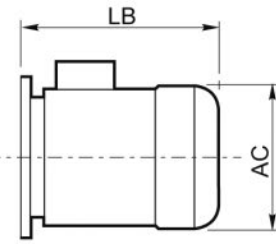
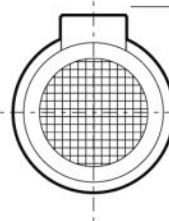

**BN**

**VR 0.25 F\_**

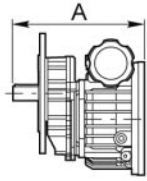

**VR 0.25 U\_**

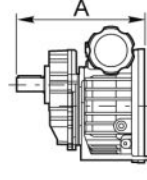

**VR 0.25 P\_**

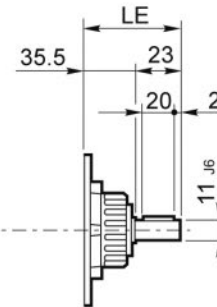
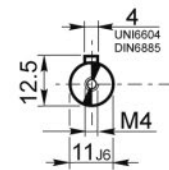

**HS**

**VR 0.25 F\_**

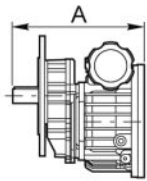

**VR 0.25 U\_**

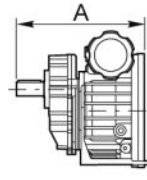

**VR 0.25 P\_**

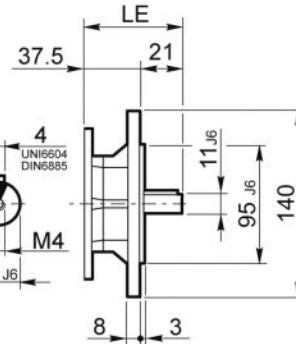
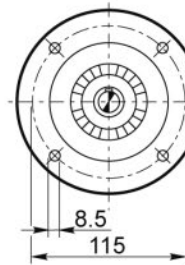

**HSF**

		AC	AD	LB	A+LB	Kg		
					D19	F	U	P
VR 0.25_P63	BN63_	121	95	184	389.5	11.7	10.9	11.6
	BN71R_	138	108	219	424.5	13.2	12.4	13.1

	LE	A+LE	LM	A+LM	Kg		
		D19		D19	F	U	P
VR 0.25_HS	58.5	264	—	—	8.9	8.1	8.8
VR 0.25_HSF	58.5	264	—	—	9.4	8.6	9.3

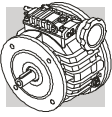

# V 0.5

## V 0.5 F\_P71 V 0.5 F\_P80

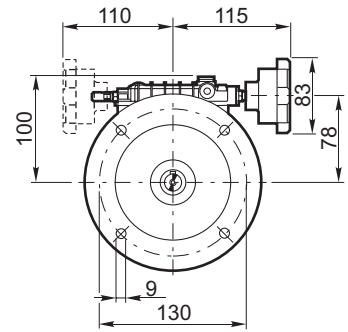
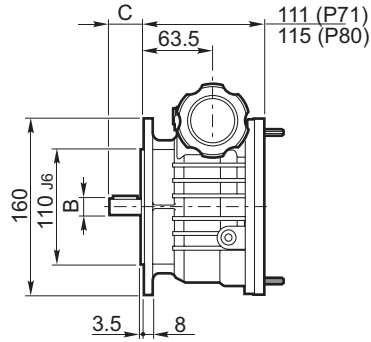
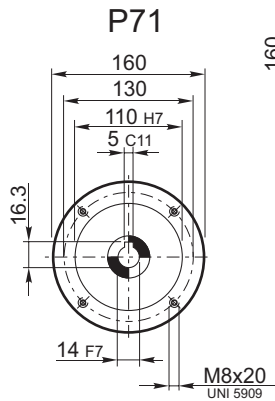

## V 0.5 UP\_P71

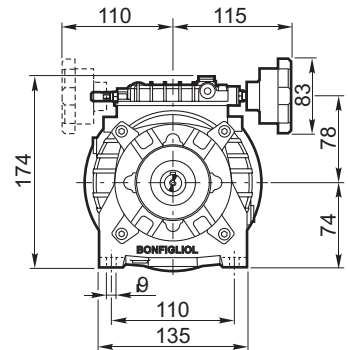
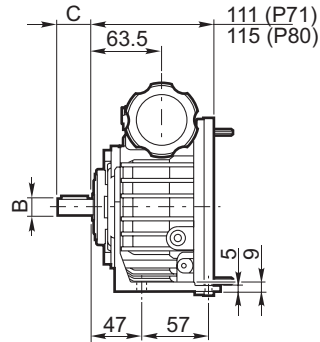

## V 0.5 UF\_P71 V 0.5 UF\_P80

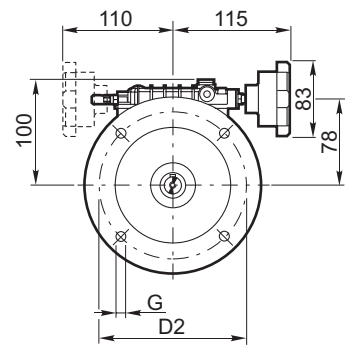
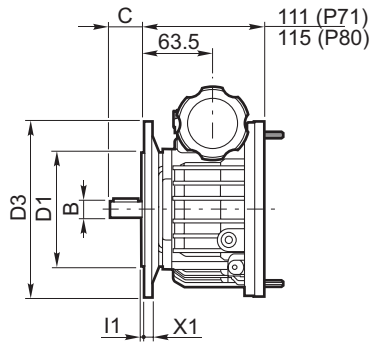
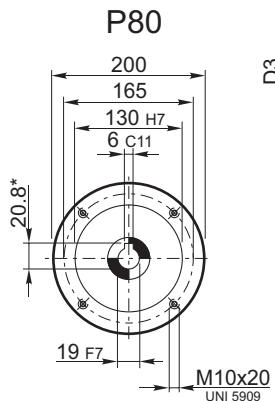

## V 0.5 UPF\_P71

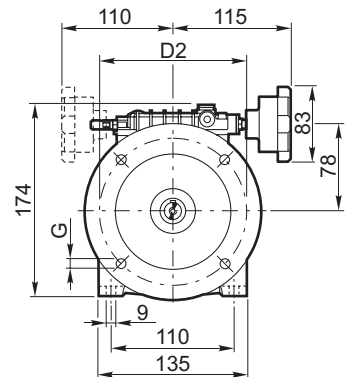
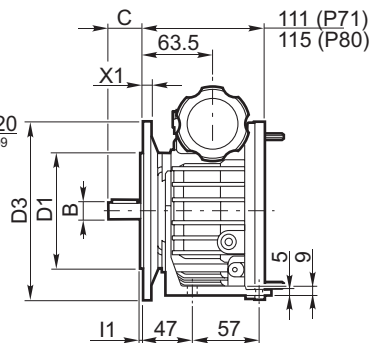

\* Utilizzare linguetta ribassata di ns. fornitura 6x5x30 "A"

\* Use thin parallel key 6x5x30 "A" supplied by Bonfiglioli

\* Den bei uns verfügbaren flachen Federkeil "A" 6x5x30 verwenden

\* Utiliser une languette abaissée de notre fabrication 6x5x30 "A"

F-UP-UF-UPF	B j6	B1	B2	B3	B4	C	U
V 0.5_D14	14	16	5	2.5	25	30	M5
V 0.5_D19	19	21.5	6	5	30	40	M6

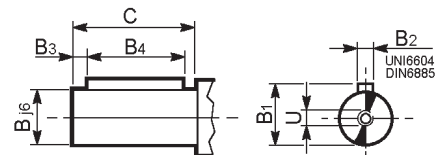

UF-UPF	D1 j6	D2	D3	G	I1	X1
V 0.5 UF71_	110	130	160	9	3.5	8
V 0.5 UF80_	130	165	200	11.5	3.5	10

V 0.5_P71	Kg			
	F	UP	UF	UPF
	7.5	8.0	8.1	8.3



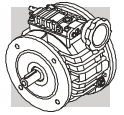

**V 0.5 F\_P71**  
**V 0.5 F\_P80**

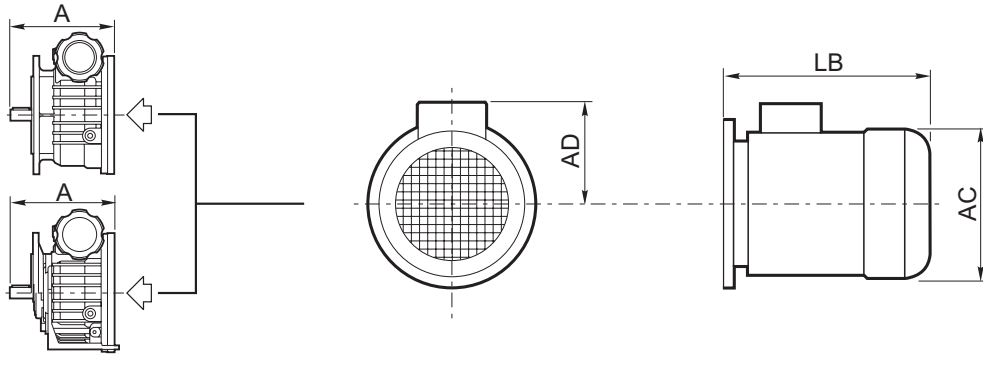

**BN**

**V 0.5 UP\_P71**  
**V 0.5 UF\_P71**  
**V 0.5 UF\_P80**  
**V 0.5 UPF\_P71**

**V 0.5 F\_**

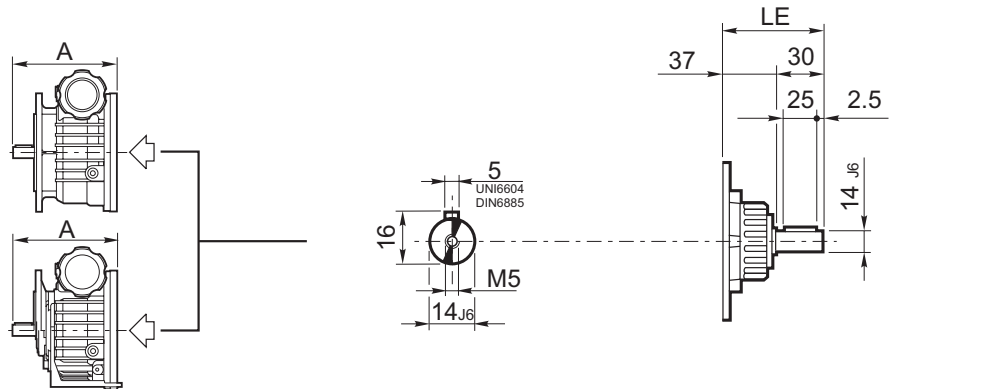

**HS**

**V 0.5 UP\_**  
**V 0.5 UF\_**  
**V 0.5 UPF\_**

**V 0.5 F\_**

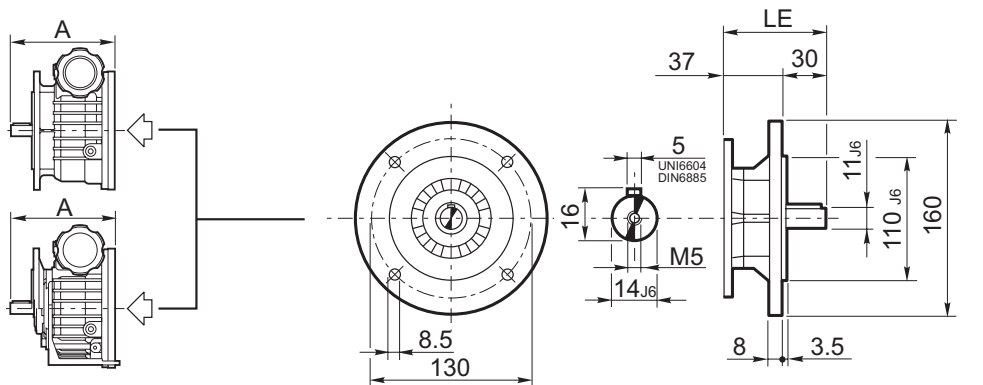

**HSF**

**V 0.5 UP\_**  
**V 0.5 UF\_**  
**V 0.5 UPF\_**

		AC	AD	LB	A+LB		Kg			
					D14	D19	F	UP	UF	UPF
V 0.5_P71	BN71_	138	108	219	360	370	13.4	13.9	14.0	14.2
V 0.5_P80	BN80_	156	119	234	379	389	17.4	—	18.0	—

	LE	A+LE		LM	A+LM		Kg			
		D14	D19		D14	D19	F	UP	UF	UPF
V 0.5_HS	67	208	218	—	—	—	9.1	9.6	9.7	9.9
V 0.5_HSF	67	208	218	—	—	—	10.0	10.5	10.6	10.8

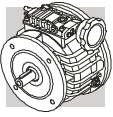

# VR 0.5

**VR 0.5 U\_P71**

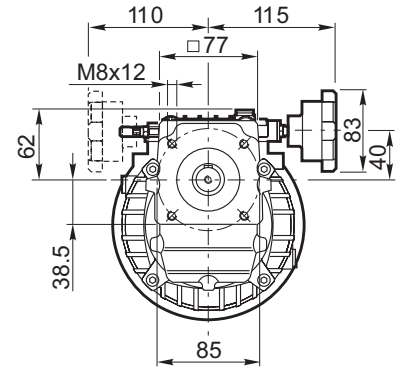
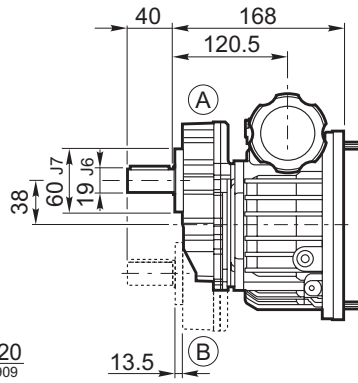
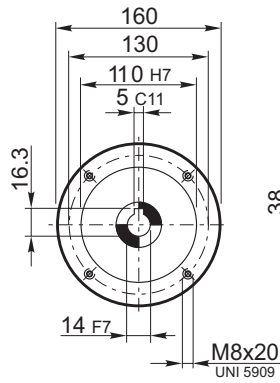

**VR 0.5 P\_P71**

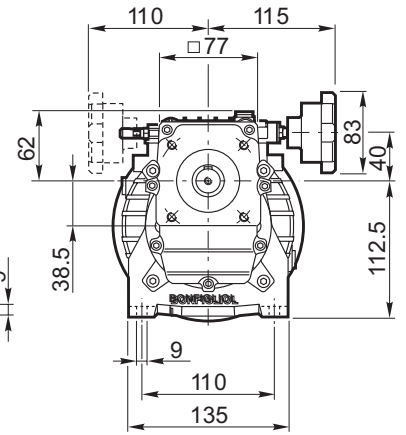
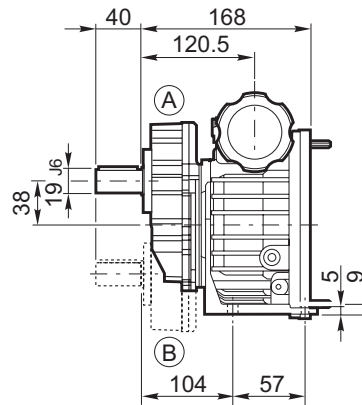
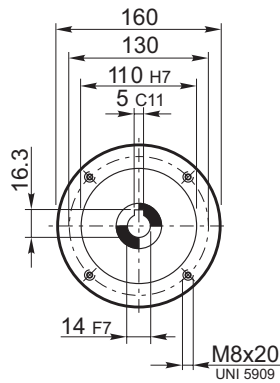

**VR 0.5 F\_P71**

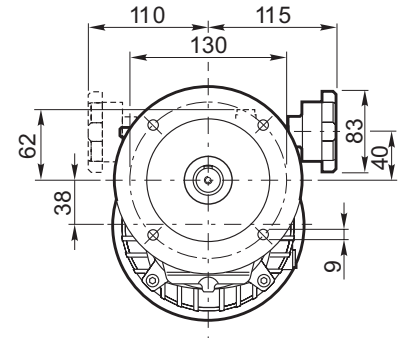
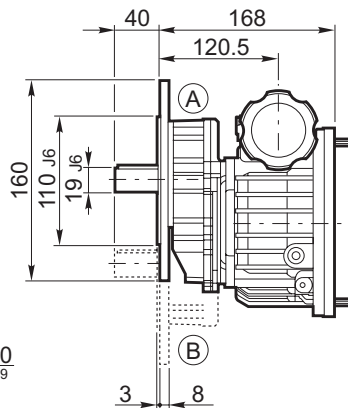
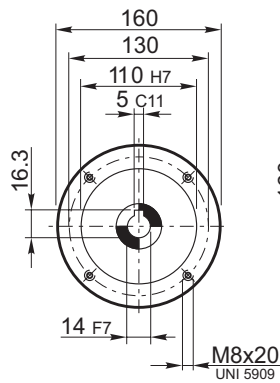

U-P-F	B j6	B1	B2	B3	B4	C	U
VR 0.5	19	21.5	6	3	35	40	M6

	Kg		
	F	U	P
VR 0.5_P71	10.9	10.1	10.8

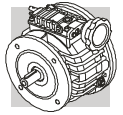

**VR 0.5 F\_P71**

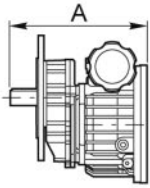

**VR 0.5 U\_P71**

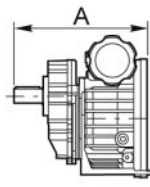

**VR 0.5 P\_P71**

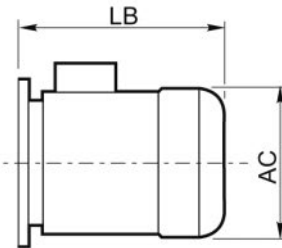
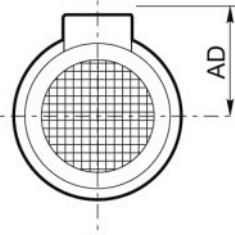

**BN**

**VR 0.5 F\_**

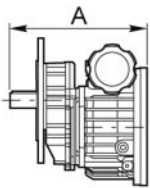

**VR 0.5 U\_**

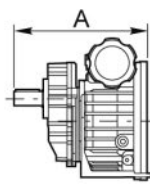

**VR 0.5 P\_**

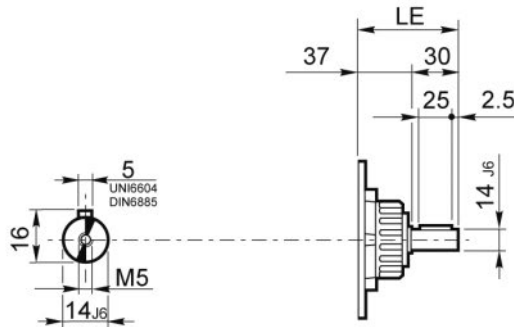

**HS**

**VR 0.5 F\_**

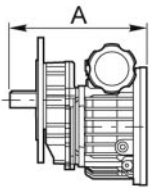

**VR 0.5 U\_**

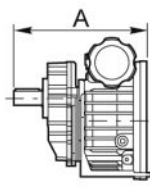

**VR 0.5 P\_**

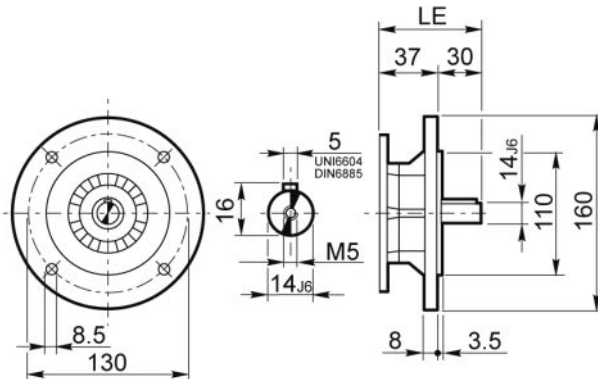

**HSF**

		AC	AD	LB	A+LB			
					D19	F	U	P
VR 0.5_P71	BN71_	138	108	219	427	16.8	16	16.7

	LE	A+LE		LM	A+LM		Kg	
		D19			D19		F	U
VR 0.5_HS	67		275	—	—	12.5	11.7	12.4
VR 0.5_HSF	67		275	—	—	13.4	12.6	13.3

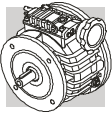

# V 1

**V 1 F\_P80**  
**V 1 F\_P90**

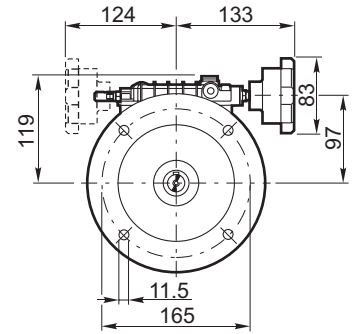
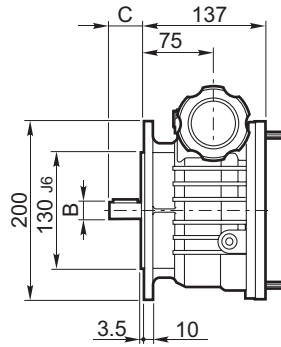
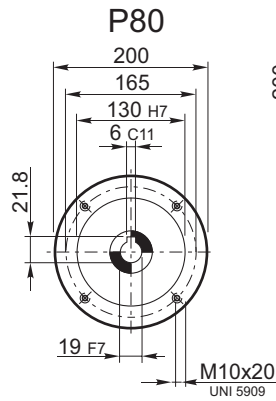

**V 1 UP\_P80**  
**V 1 UP\_P90**

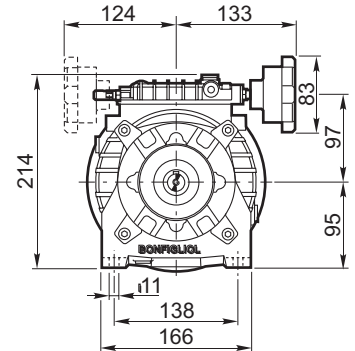
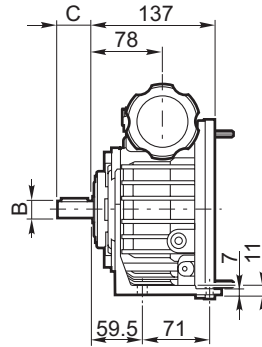

**V 1 UF\_P80**  
**V 1 UF\_P90**

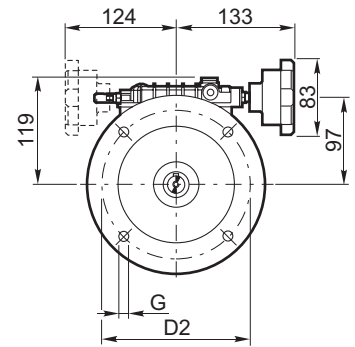
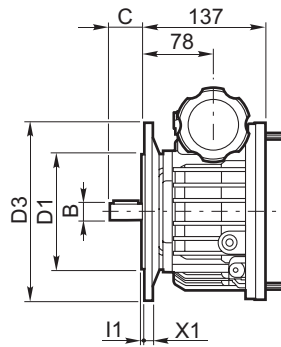
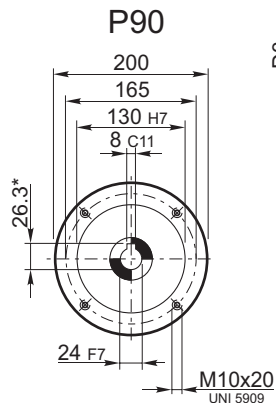

**V 1 UPF\_P80**  
**V 1 UPF\_P90**

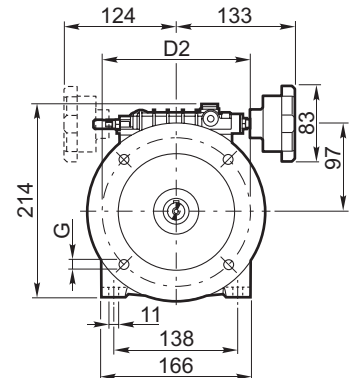
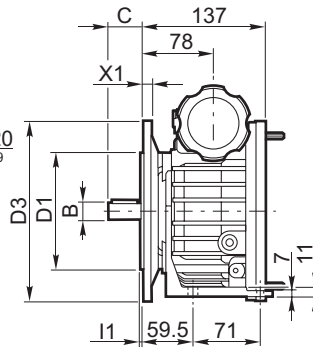

\* Utilizzare linguetta ribassata di ns. fornitura 8x6x35 "A"

\* Use thin parallel key 8x6x35 "A" supplied by Bonfiglioli

\* Den bei uns verfügbaren flachen Federkeil "A" 8x6x35 verwenden

\* Utiliser une languette abaissée de notre fabrication 8x6x35 "A"

F-UP-UF-UPF	B j6	B1	B2	B3	B4	C	U
V 1_D19	19	21.5	6	5	30	40	M6
V 1_D24	24	27	8	5	40	50	M8

UF-UPF	D1 j6	D2	D3	G	I1	X1
V 1 UF80_	130	165	200	11.5	3.5	10
V 1 UF90_	130	165	200	11.5	3.5	10

V 1_P80	Kg			
	F	UP	UF	UPF
	14.1	14.0	14.2	14.5

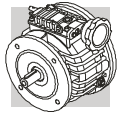

V 1 F\_P80  
V 1 F\_P90

V 1 UP\_P80  
V 1 UF\_P80  
V 1 UF\_P90  
V 1 UPF\_P80

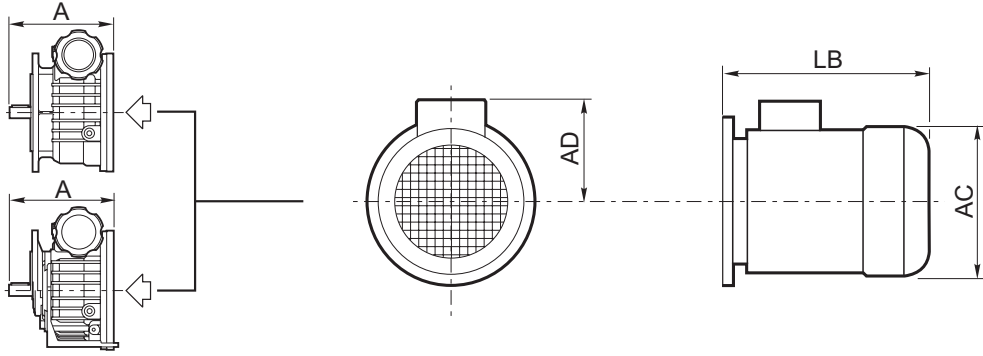

**BN**

V 1 F\_

V 1 UP\_  
V 1 UF\_  
V 1 UPF\_

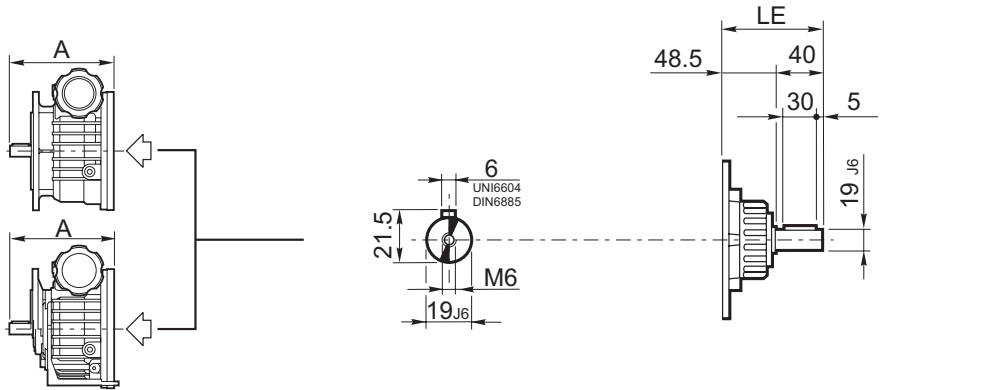

**HS**

V 1 F\_

V 1 UP\_  
V 1 UF\_  
V 1 UFP\_

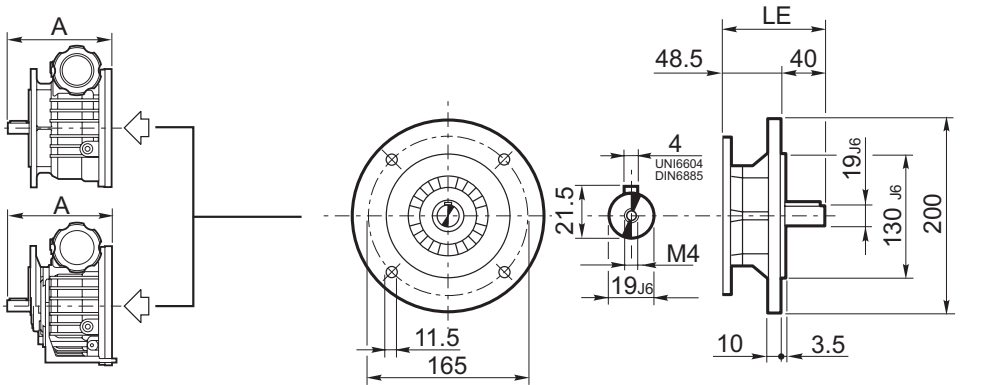

**HSF**

		AC	AD	LB	A+LB		Kg			
					D19	D24	F	UP	UF	UPF
V 1_P80	BN80_	156	119	234	411	421	24	24	24	24
V 1_P90	BN90S_	176	133	276	453	463	26	26	27	27
V 1_P90	BN90L_	176	133	276	453	463	26	28	27	27

	LE	A+LE		LM	A+LM		Kg			
		D19	D24		D19	D24	F	UP	UF	UPF
V 1_HS	88.5	265.5	275.5	—	—	—	16.9	16.8	17.0	17.3
V 1_HSF	88.5	265.5	275.5	—	—	—	18.6	18.5	18.7	19.0

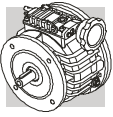

# VR 1

**VR 1 U\_P80**

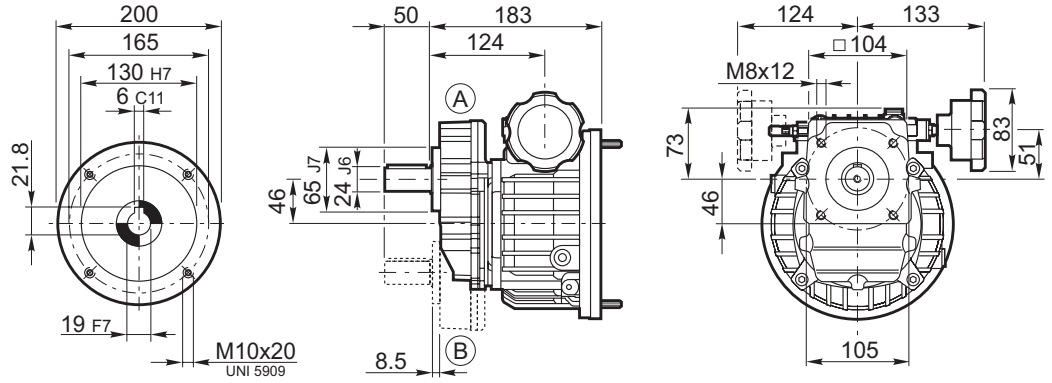

**VR 1 P\_P80**

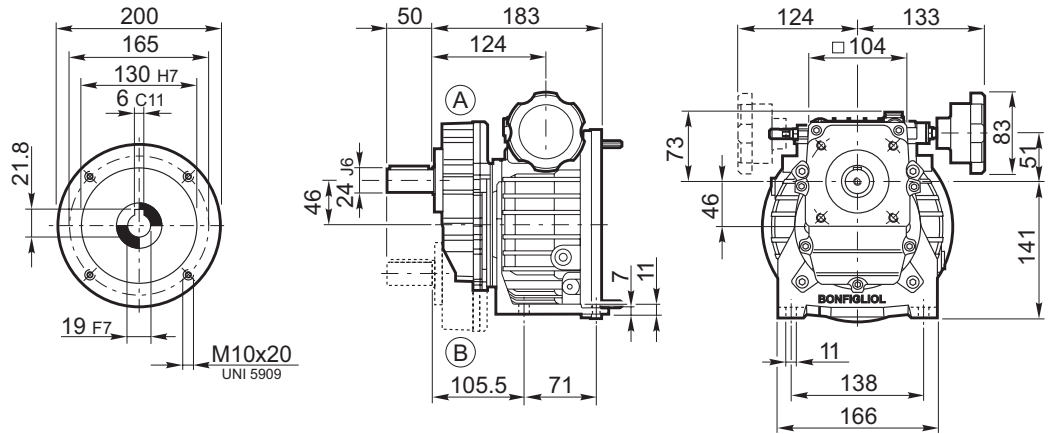

**VR 1 F\_P80**

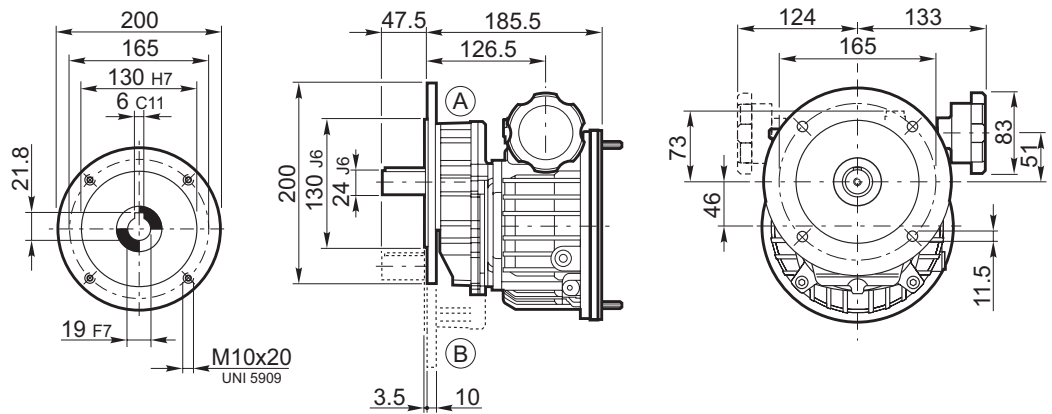

U-P-F	B j6	B1	B2	B3	B4	C	U	
VR 1	24	27	8	3	45	50 (UP) 47.5 (F)	M8	

	Kg		
	F	U	P
VR 1_P80	17.7	16.2	17.5

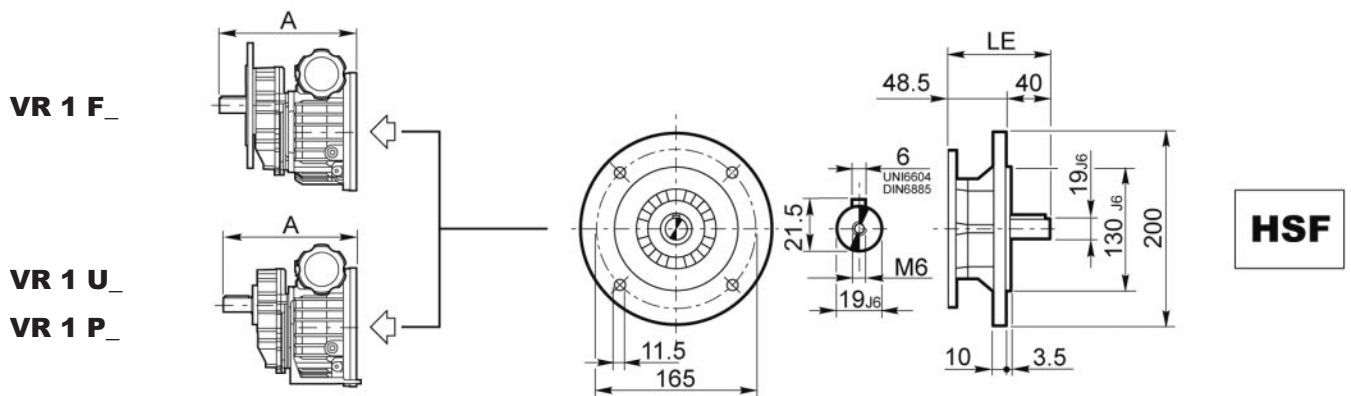
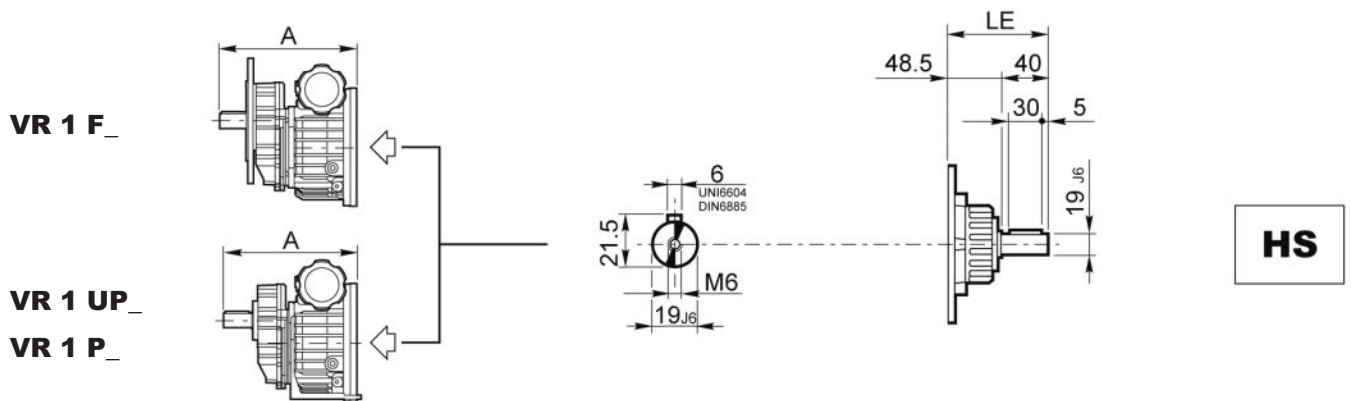
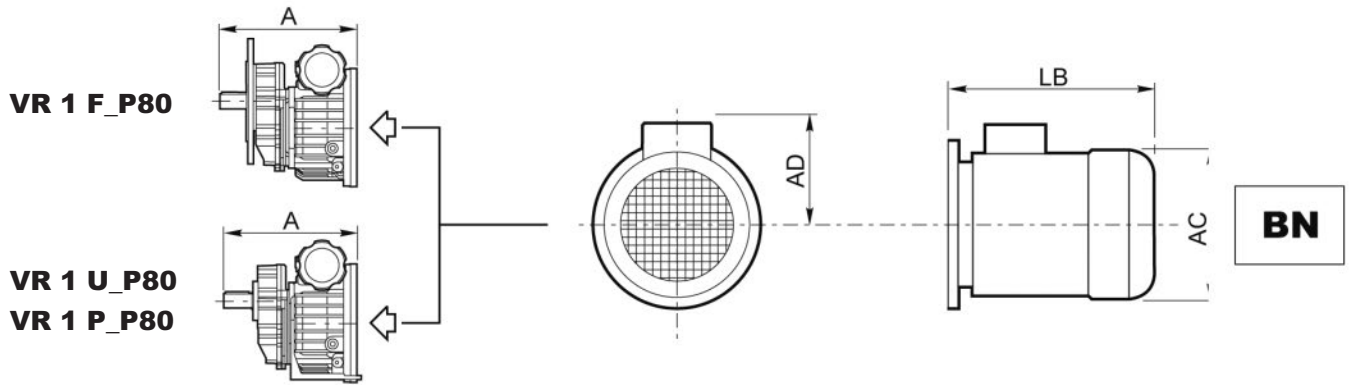
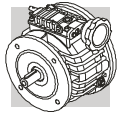

	AC	AD	LB	A+LB		Kg		
				D24	F	U	P	
VR 1_P80	BN80_	156	119	234	467	28	26	27

	LE	A+LE		LM	A+LM		Kg		
		D24			D24	F	U	P	
VR 1_HS	88.5	321.5				21	19.0	20	
VR 1_HSF	88.5	321.5				22	21	22	

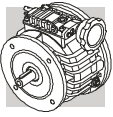

# V 2

**V 2 F\_P90**

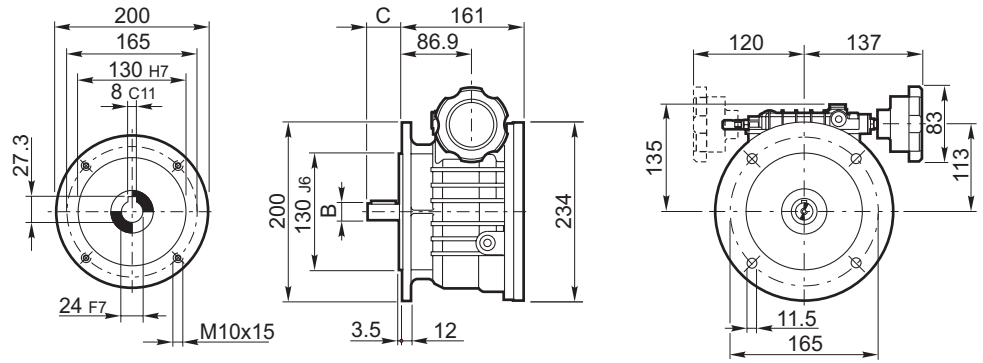

**V 2 UP\_P90**

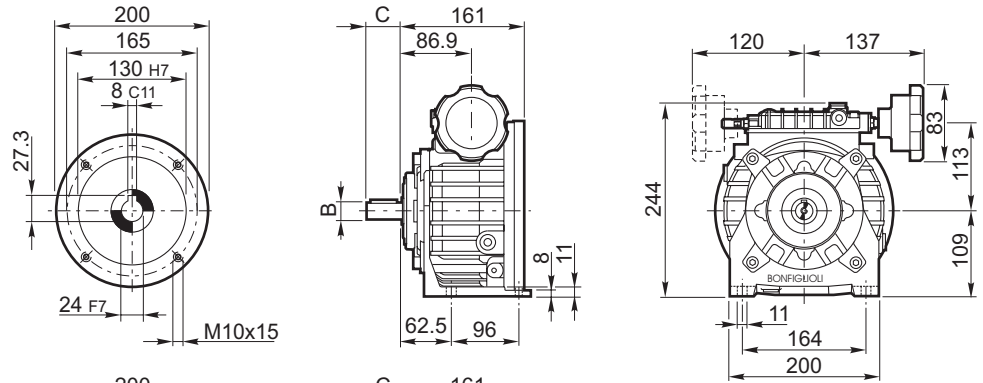

**V 2 UF\_P90**

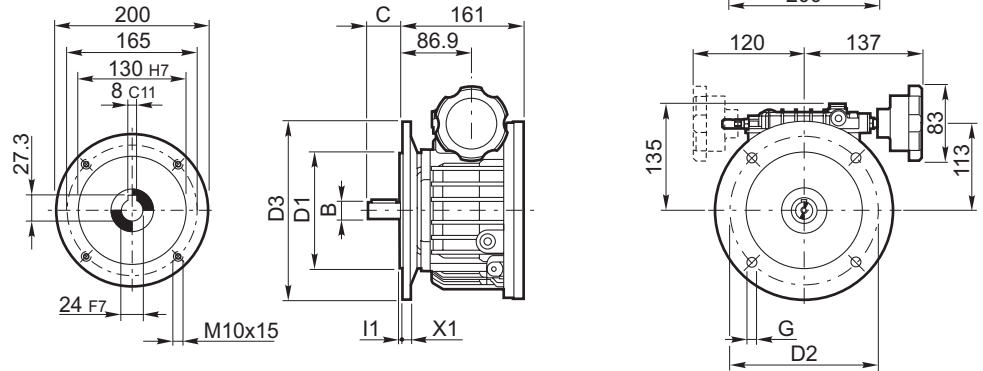

**V 2 UPF\_P90**

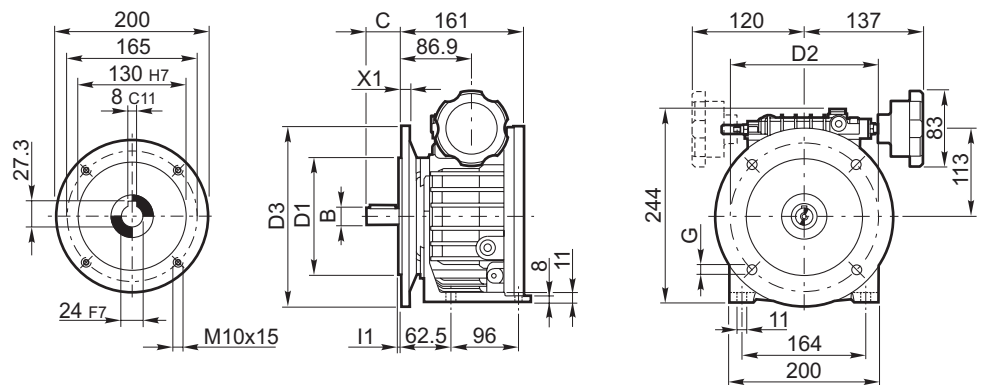

F-UP-UF-UPF	B j6	B1	B2	B3	B4	C	U
V 2_D24	24	27	8	5	40	50	M8
V 2_D28	28	31	8	5	50	60	M10

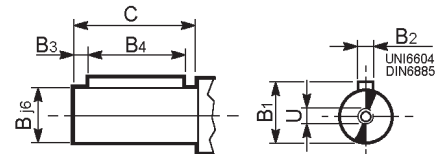

UF-UPF	D1 j6	D2	D3	G	I1	X1	Kg			
V 2 UF90_	130	165	200	11.5	3.5	12				
V 2 UF100_	180	215	250	14	4	14				
V 2_P90							F	U	UF	UP
							18.8	20	21	21



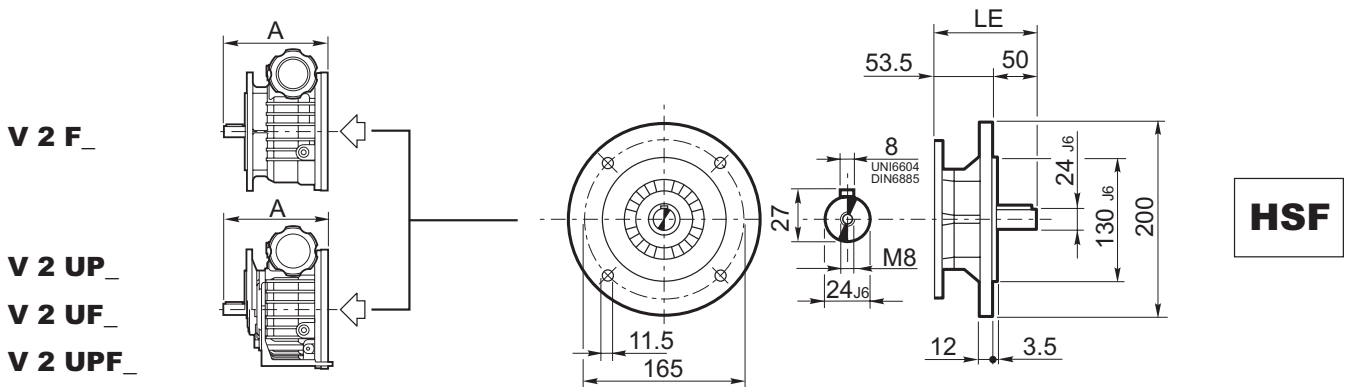
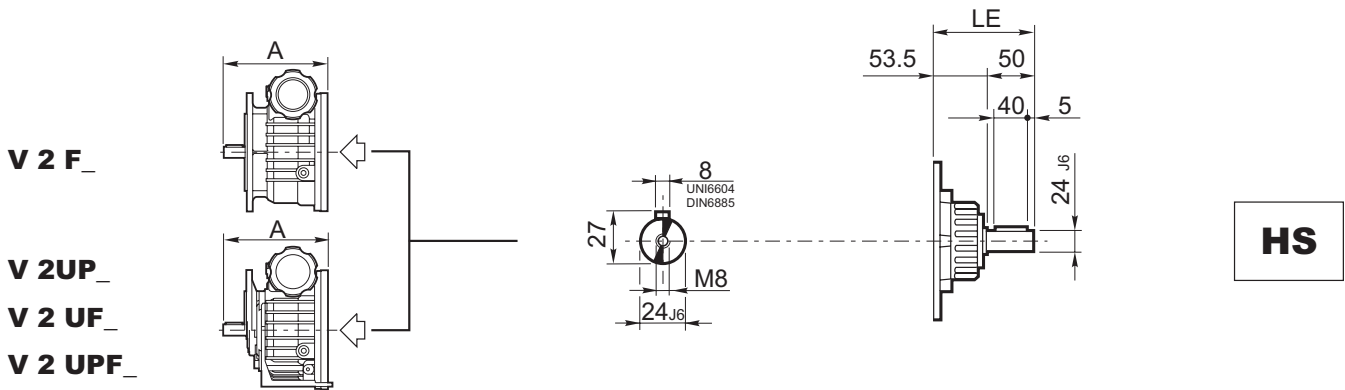
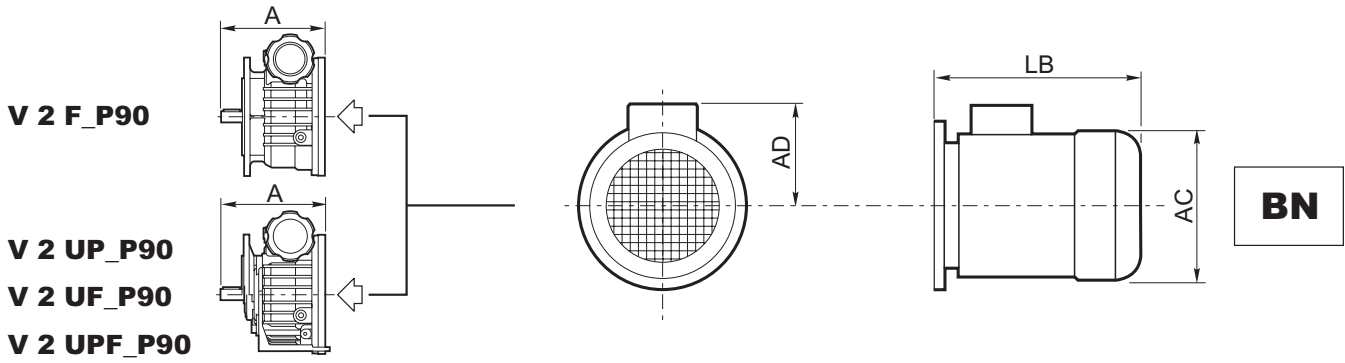
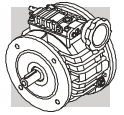

		AC	AD	LB	A+LB		Kg			
					D24	D28	F	U	UF	UP
V 2_P90	BN90S_	176	133	276	487	497	31	33	33	33
	BN90L_	176	133	276	487	497	33	35	35	35
	BN100R_	195	142	307	518	528	41	43	43	43

	LE	A+LE		LM	A+LM		Kg			
		D24	D28		D24	D28	F	U	UF	UP
V 2_HS	103.5	314.5	324.5	—	—	—	23	24	25	25
V 2_HSF	103.5	314.5	324.5	—	—	—	25	26	26	27

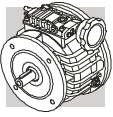

# VR 2

**VR 2 U\_P90**

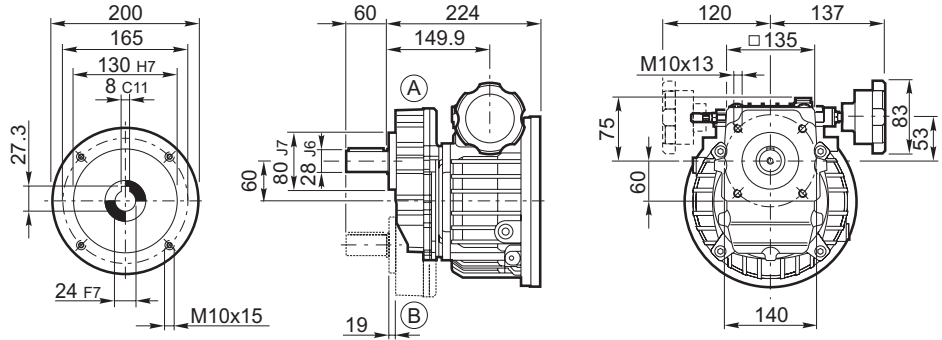

**VR 2 P\_P90**

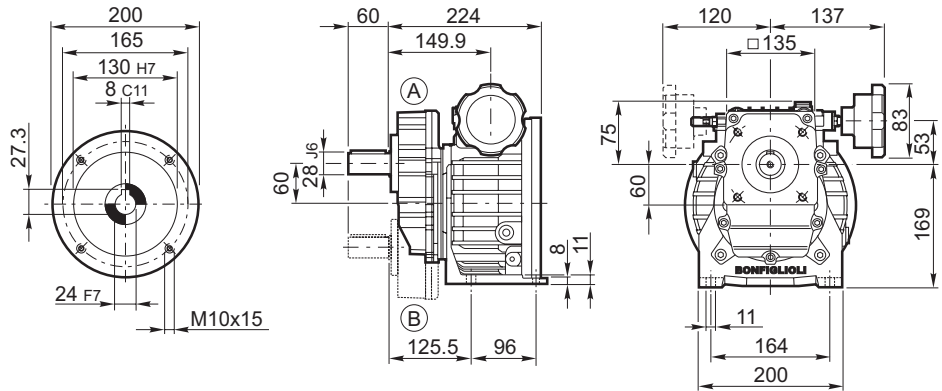

**VR 2 F\_P90**

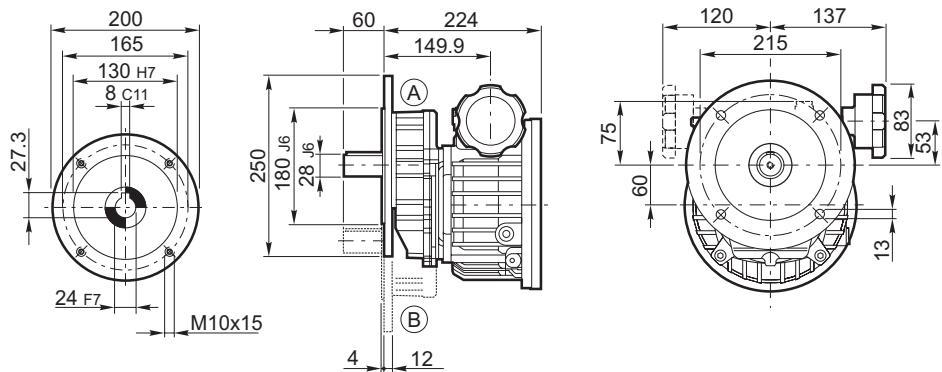

U-P-F	B j6	B1	B2	B3	B4	C	U	
VR 2	28	31	8	5	50	60	M10	

	Kg		
	F	U	P
VR 2_P90	27	25	27

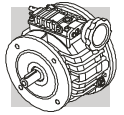

**VR 2 F\_P90**

**VR 2 U\_P90**

**VR 2 P\_P90**

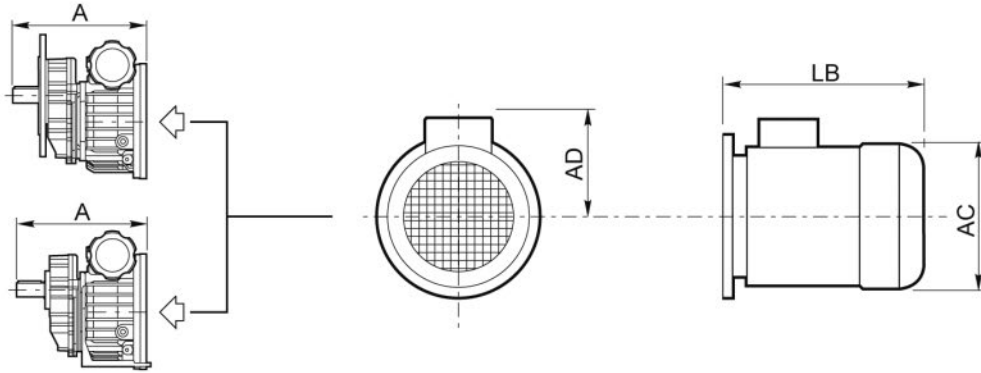

**BN**

**VR 2 F\_**

**VR 2 U\_**

**VR 2 P\_**

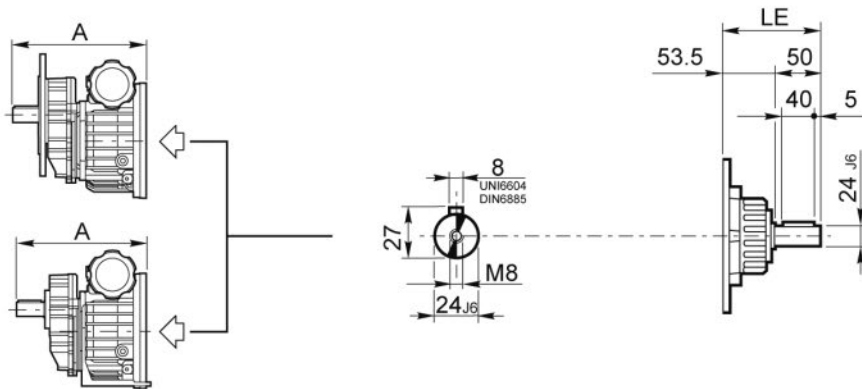

**HS**

**VR 2 F\_**

**VR 2 U\_**

**VR 2 P\_**

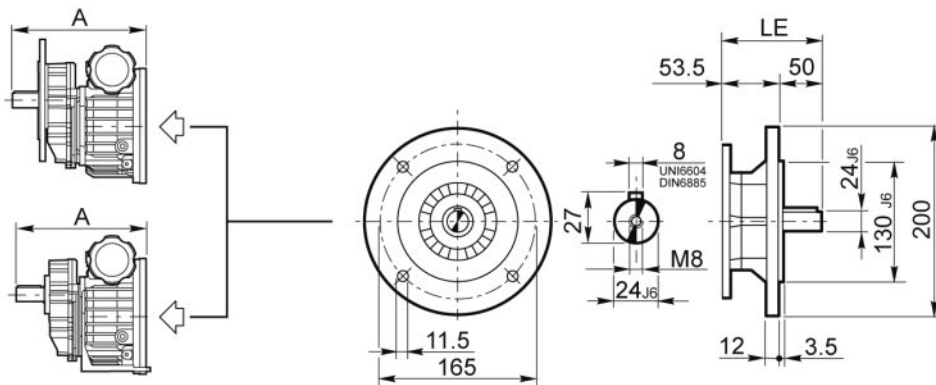

**HSF**

		AC	AD	LB	A+LB	Kg		
					D28	F	U	P
VR 2_P90	BN90S_	176	133	276	560	39	37	40
	BN90L_	176	133	276	560	41	39	41
	BN100R_	195	142	307	591	49	47	49

	LE	A+LE	LM	A+LM	Kg		
		D28		28	F	U	P
VR 2_HS	103.5	387.5	—	—	31	29	31
VR 2_HSF	103.5	387.5	—	—	33	31	32

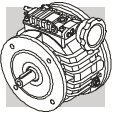

# V 3

**V 3 F\_P100**  
**V 3 F\_P112**

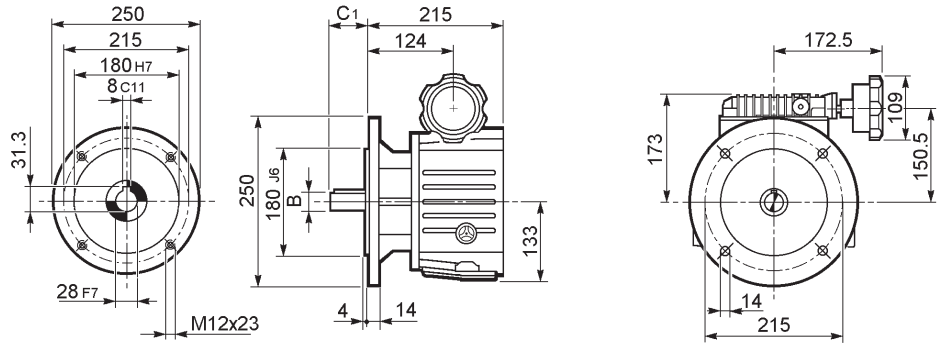

**V 3 U\_P100**  
**V 3 U\_P112**

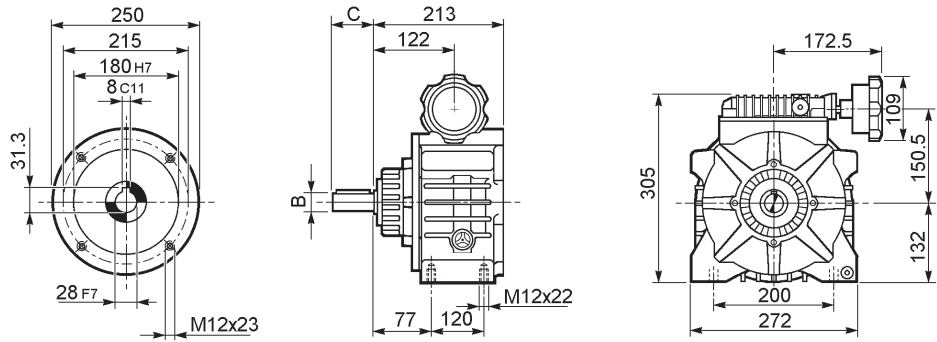

**V 3 UF\_P100**  
**V 3 UF\_P112**

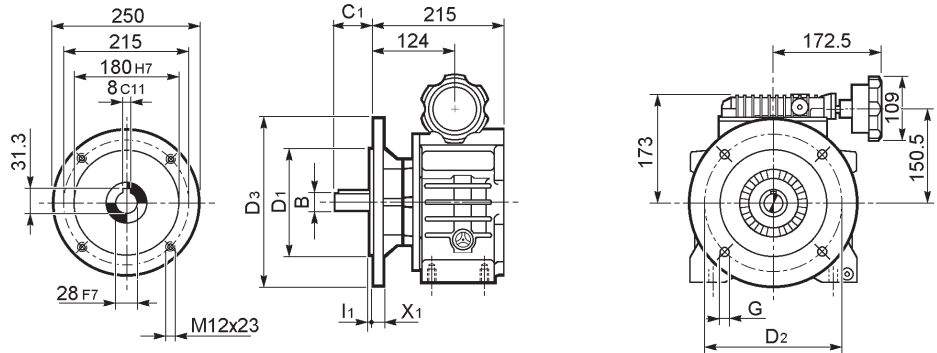

**V 3 UP\_P100**  
**V 3 UP\_P112**

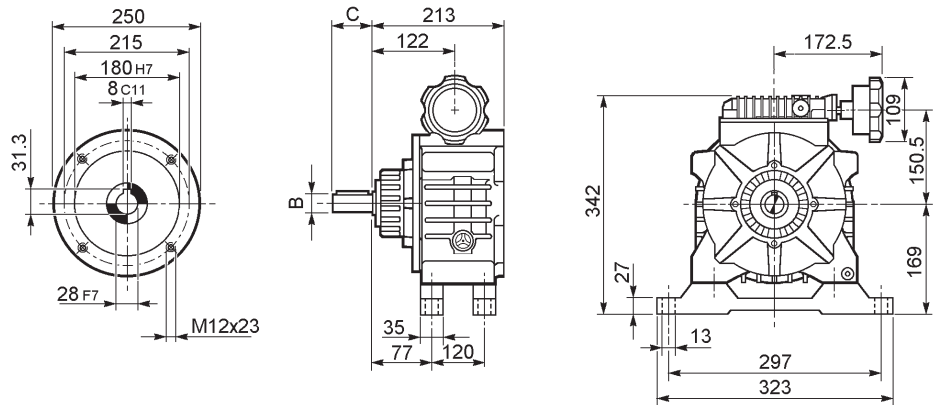

F-U-UF-UP	B j6	B1	B2	B3	B4	C	C1	U
V 3_D28	28	31	8	5	50	60	58	M10
V 3_D38 *	38	41	10	5	70	80	78	M12

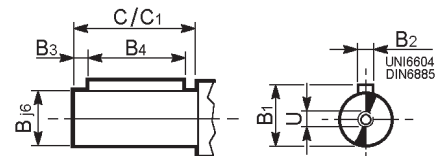

\* Non previsto nella esecuzione con differenziale; se richiesto, consultare il ns. Servizio tecnico commerciale.

\* Not available on versions featuring the differential unit. If required, please contact our Technical Service Dept.

\* Nicht in der Ausführung mit Differential vorgesehen. Wenn diese Einbaulage benötigt wird, informieren Sie sich bitte bei unserem technischen Kundendienst.

\* Non prévu sur la version avec différentiel; pour toute demande, consulter notre Service Après-Vente.

UF	D1 j6	D2	D3	G	I1	X1	Kg				
V 3 UF100_	180	215	250	14	4	14	F	U	UF	UP	
V 3 UF132_	230	265	300	14	4	14	V 3 P100	39	41	45	46
							V 3 P112	39	41	45	46

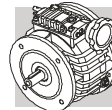

**V 3**

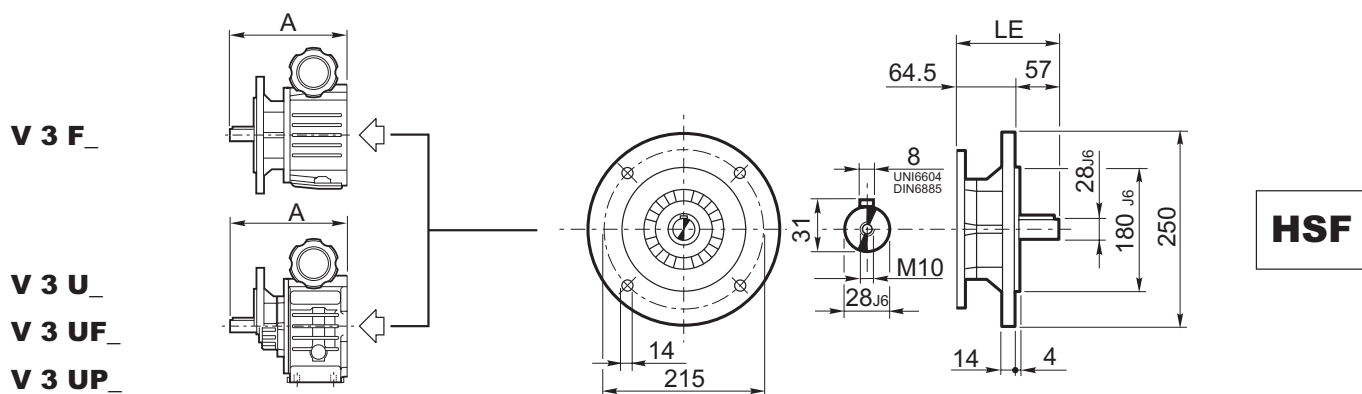
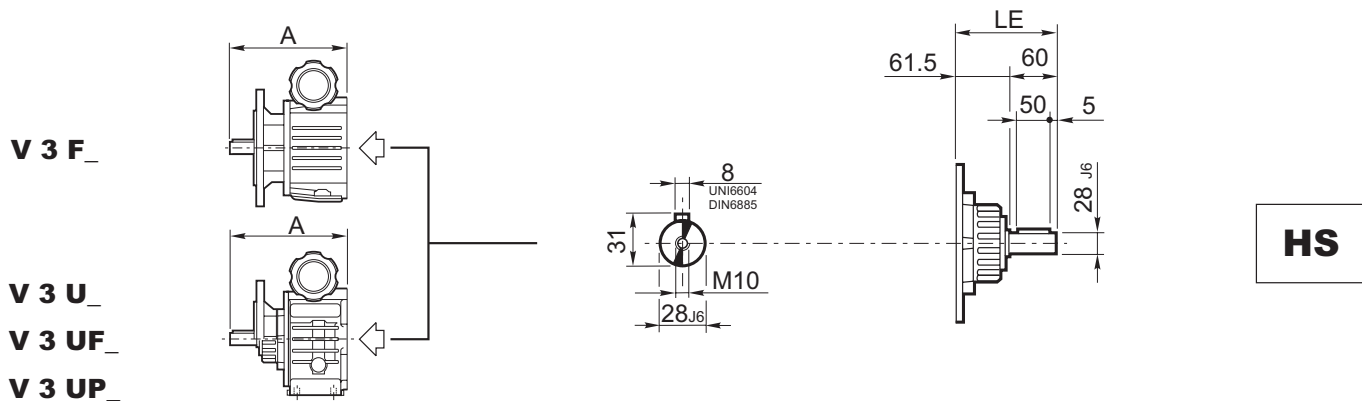
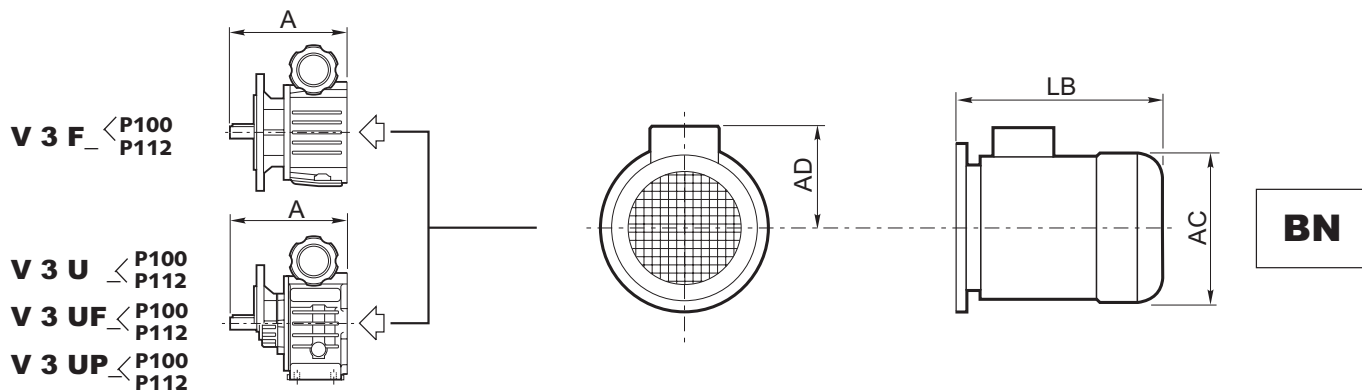

		AC	AD	LB	A+LB		Kg			
					D28	D38	F	U	UF	UP
V 3_P100	BN100_	195	142	307	580	600	61	63	67	68
V 3_P112	BN112_	219	157	325	598	618	67	69	73	74

	LE	A+LE		LM	A+LM		Kg			
		D28	D38		D28	D38	F	U	UF	UP
V 3_HS	121.5	394.5	414.5	—	—	—	46	47	52	52
V 3_HSF	121.5	394.5	414.5	—	—	—	50	52	56	57

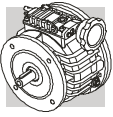

# VR 3

**VR 3 U\_P100**  
**VR 3 U\_P112**

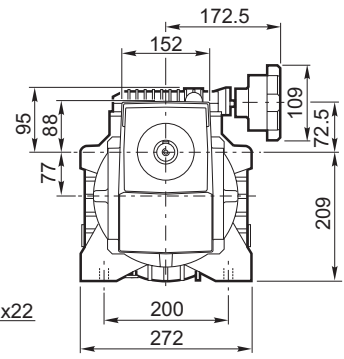
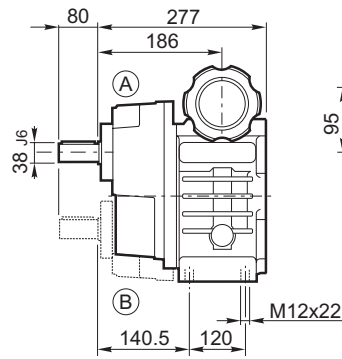
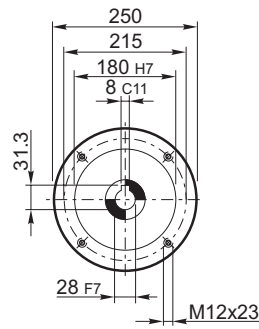

**VR 3 P\_P100**  
**VR 3 P\_P112**

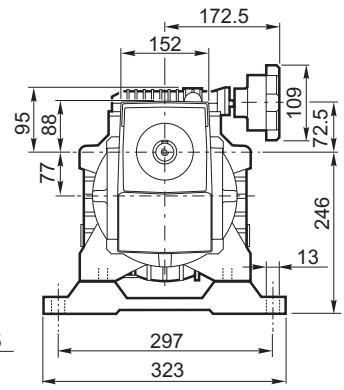
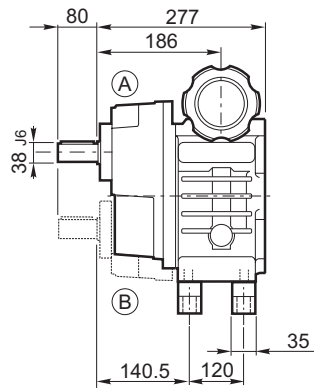
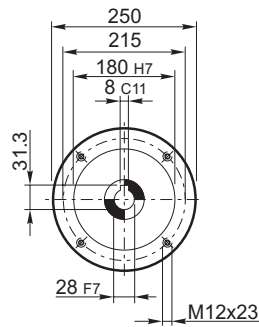

**VR 3 F\_P100**  
**VR 3 F\_P112**

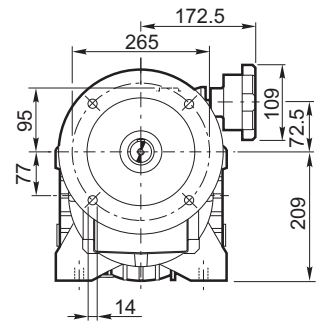
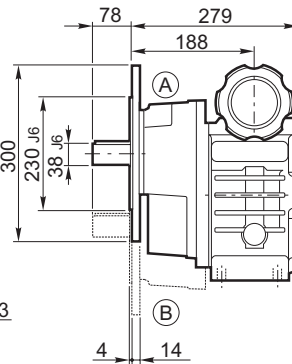
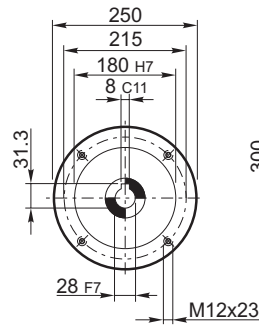

U-P-F	B j6	B1	B2	B3	B4	C	U
VR 3	38	41	10	5	70	80 (P) 78 (F)	M12

	Kg		
	U	P	F
VR 3_P100	55	60	55
VR 3_P112			

# VR 3

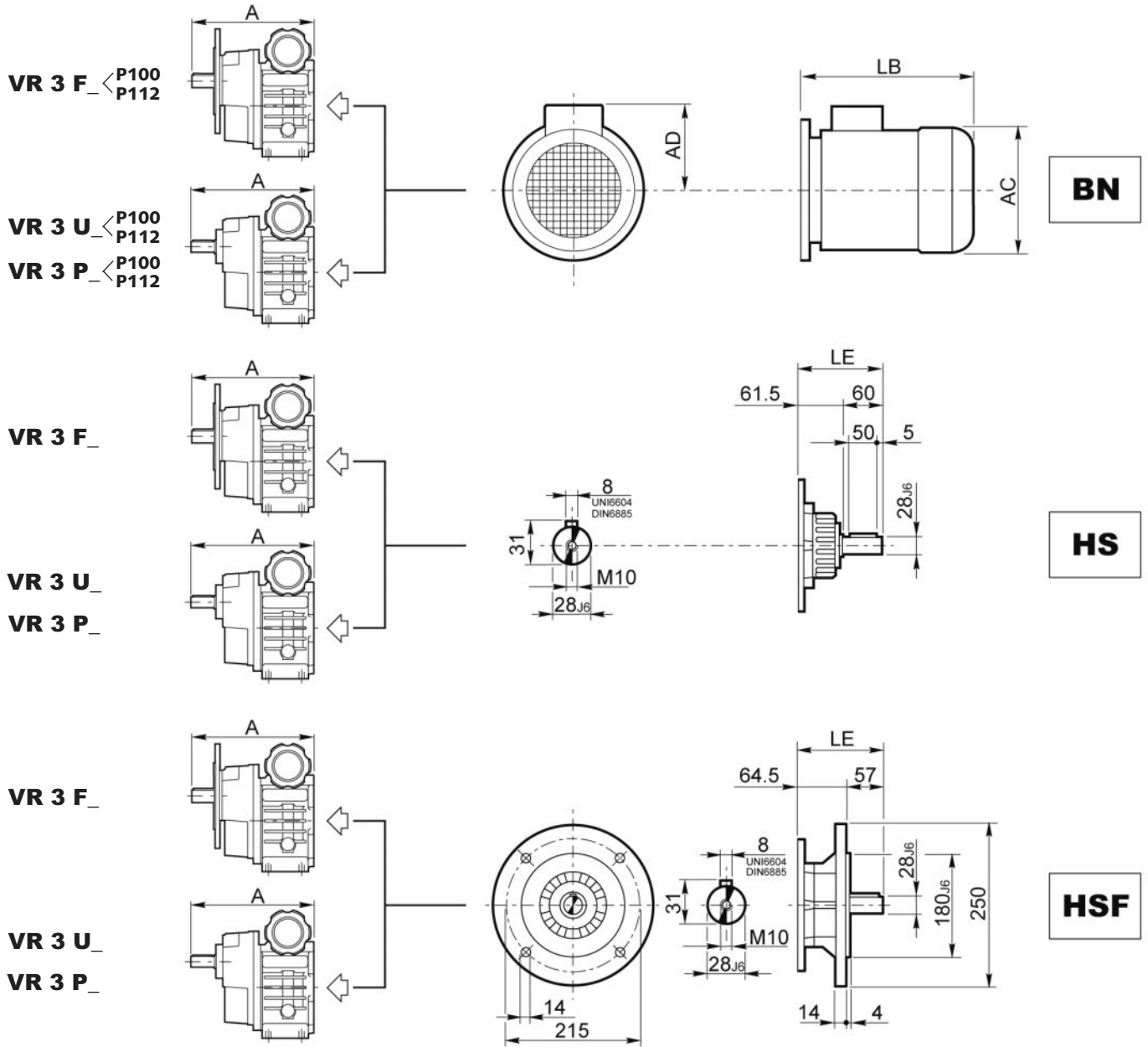
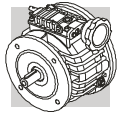

		AC	AD	LB	A+LB		Kg		
					D28	U	P	F	
VR 3_P100	BN100_	195	142	307	664	77	82	77	
VR 3_P112	BN112_	219	157	325	682	85	90	85	

	LE	A+LE		LM	A+LM		Kg		
		D38			D38	U	P	F	
VR 3_HS	121.5	478.5			62	67	62		
VR 3_HSF	121.5	478.5			66	71	66		

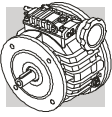

# V 5.5

**V 5.5 F\_P112**

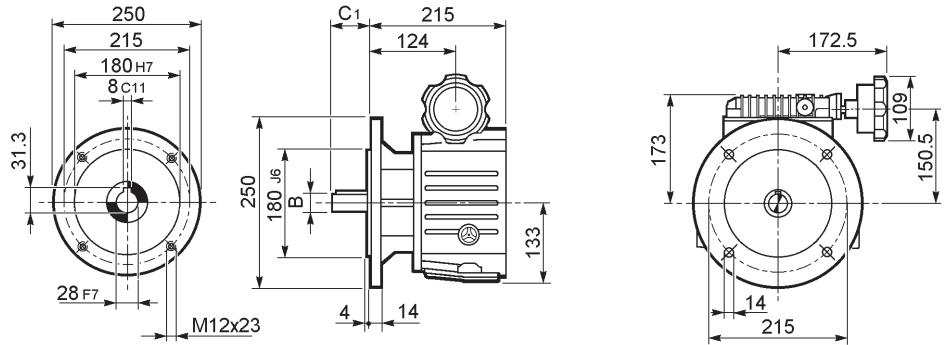

**V 5.5 U\_P112**

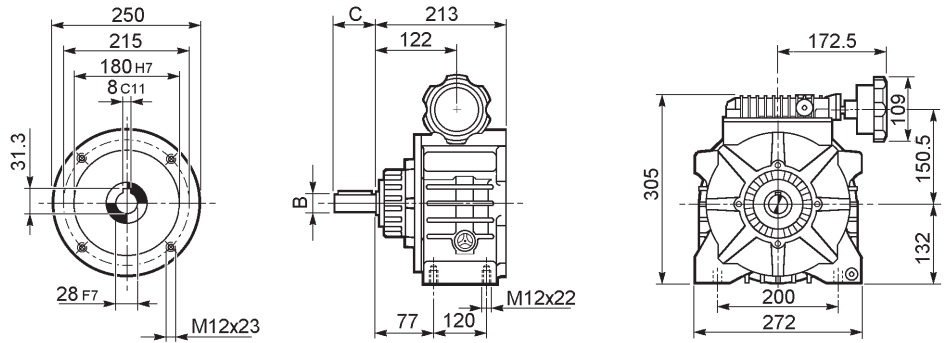

**V 5.5 UF\_P112**

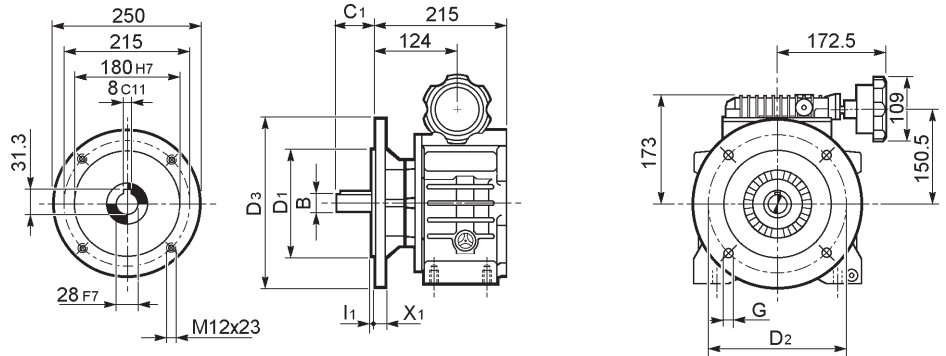

**V 5.5 UP\_P112**

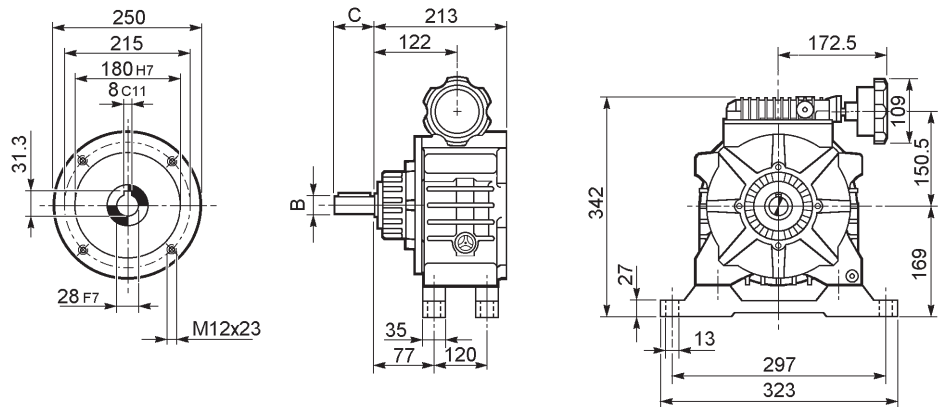

F-U-UF-UP	B j6	B1	B2	B3	B4	C	C1	U
V 5.5_D28	28	31	8	5	50	60	58	M10
V 5.5_D38 *	38	41	10	5	70	80	78	M12

\* Non previsto nella esecuzione con differenziale; se richiesto, consultare il ns. Servizio tecnico commerciale.

\* Not available on versions featuring the differential unit. If required, please contact our Technical Service Dept.

\* Nicht in der Ausführung mit Differential vorgesehen. Wenn diese Einbaulage benötigt wird, informieren Sie sich bitte bei unserem technischen Kundendienst.

\* Non prévu sur la version avec différentiel; pour toute demande, consulter notre Service Après-Vente.

UF	D1 j6	D2	D3	G	I1	X1	Kg				
V 5.5 UF112_	180	215	250	14	4	14	V 5.5_P112	F	U	UF	UP
V 5.5 UF132_	230	265	300	14	4	14		40	41	46	46



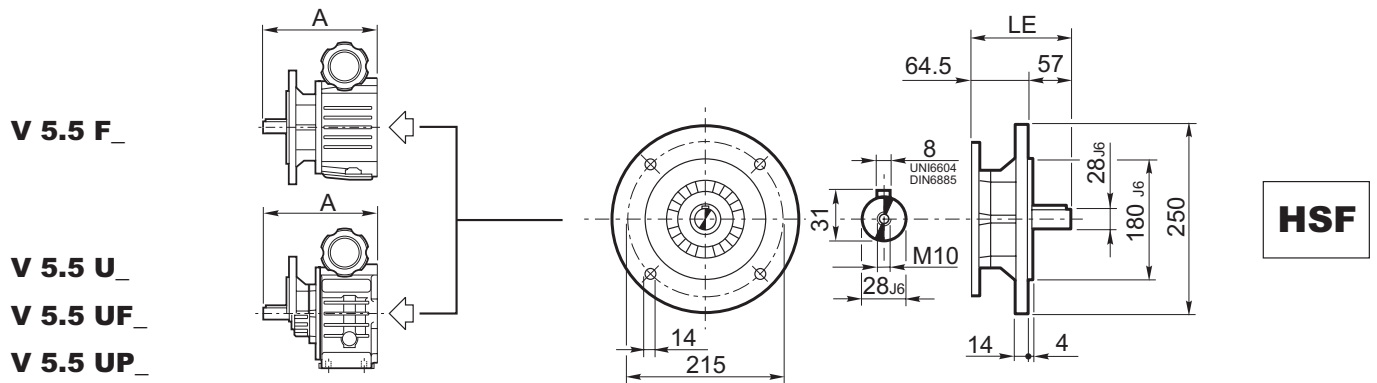
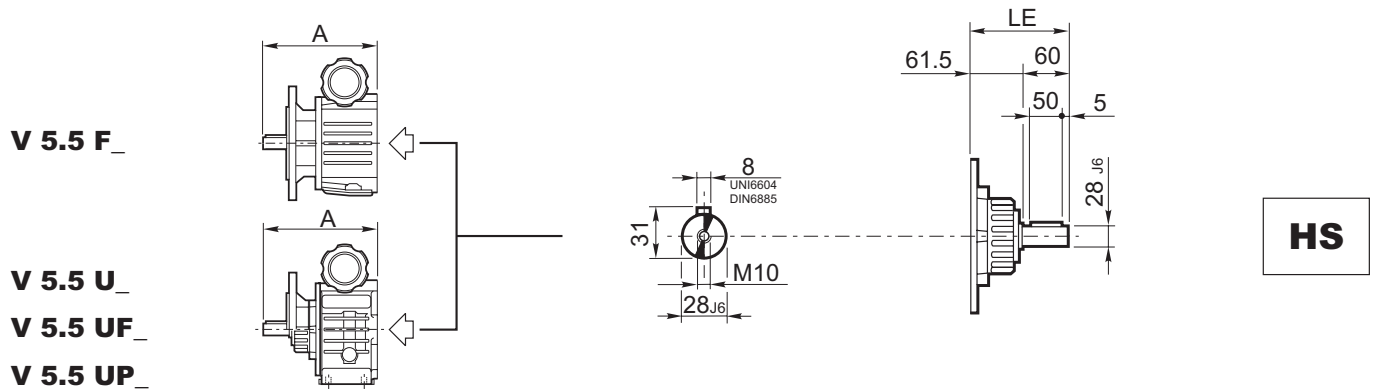
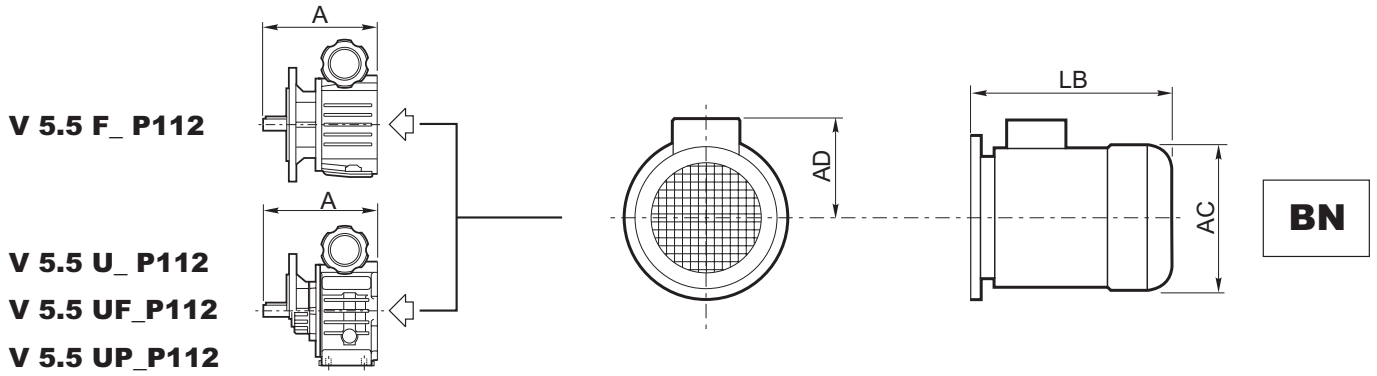
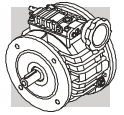

		AC	AD	LB	A+LB		Kg			
					D28	D38	F	U	UF	UP
V 5.5_P112	BN112_	219	157	325	598	618	70	71	76	76

	LE	A+LE		LM	A+LM		Kg			
		D28	D38		D28	D38	F	U	UF	UP
V 5.5_HS	121.5	394.5	414.5	—	—	—	47	48	52	53
V 5.5_HSF	121.5	394.5	414.5	—	—	—	51	52	57	57

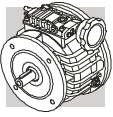

# VR 5.5

**VR 5.5 U\_P112**

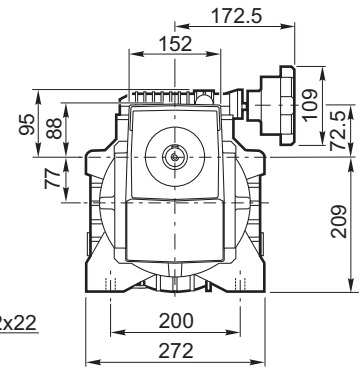
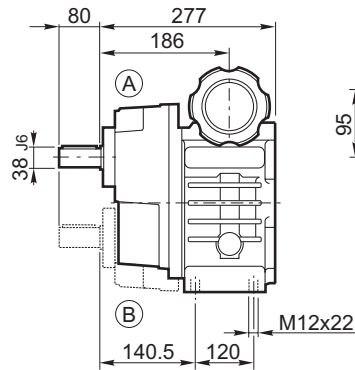
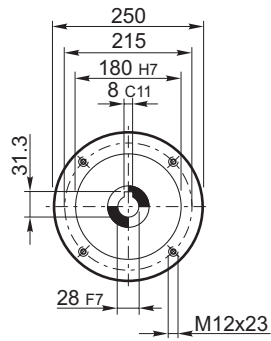

**VR 5.5 P\_P112**

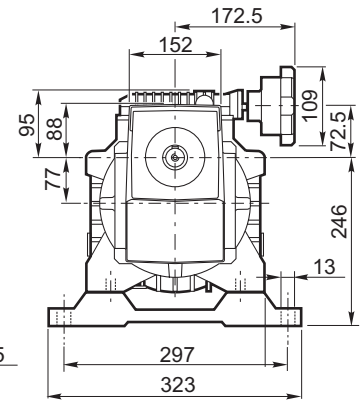
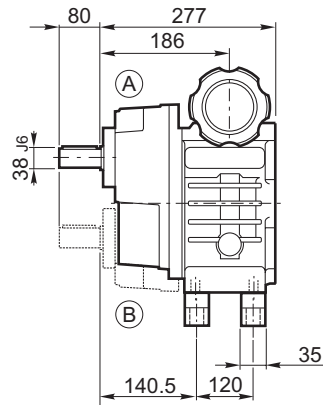
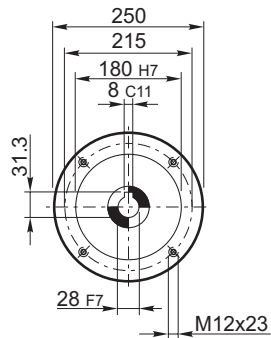

**VR 5.5 F\_P112**

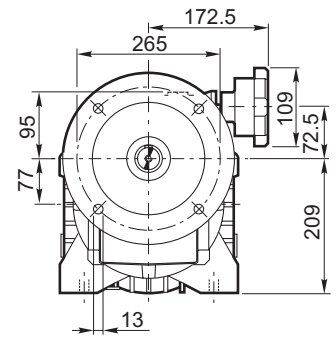
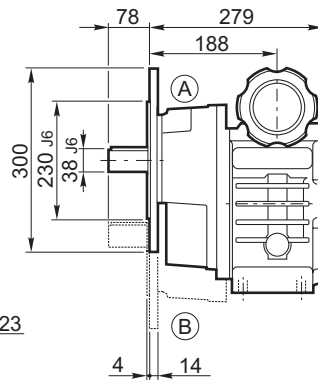
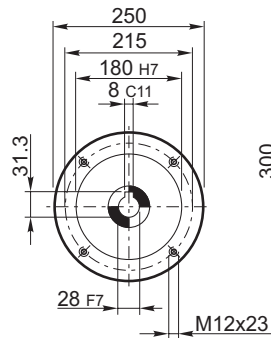

U-P-F	B j6	B1	B2	B3	B4	C	U
VR 5.5	38	41	10	5	70	80 (P) 78 (F)	M12

	Kg		
	U	P	F
VR 5.5_P112	58	63	58

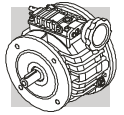

**VR 5.5 F\_P112**

**VR 5.5 U\_P112**  
**VR 5.5 P\_P112**

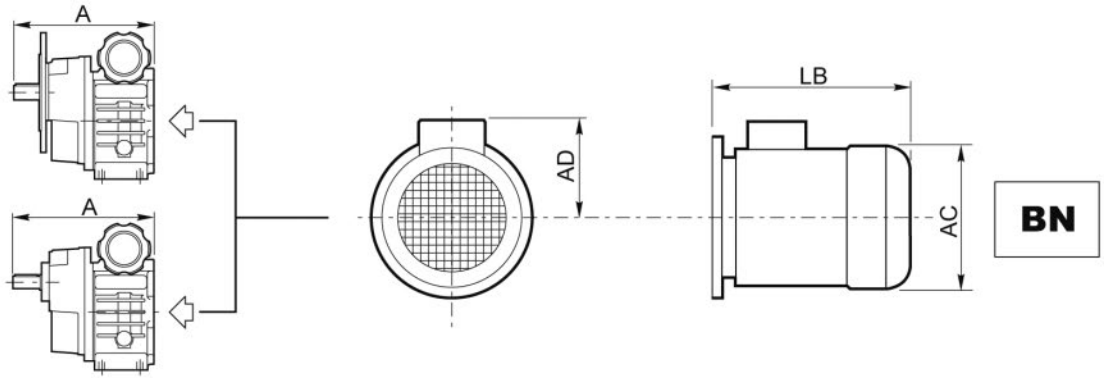

**VR 5.5 F\_**

**VR 5.5 U\_**  
**VR 5.5 P\_**

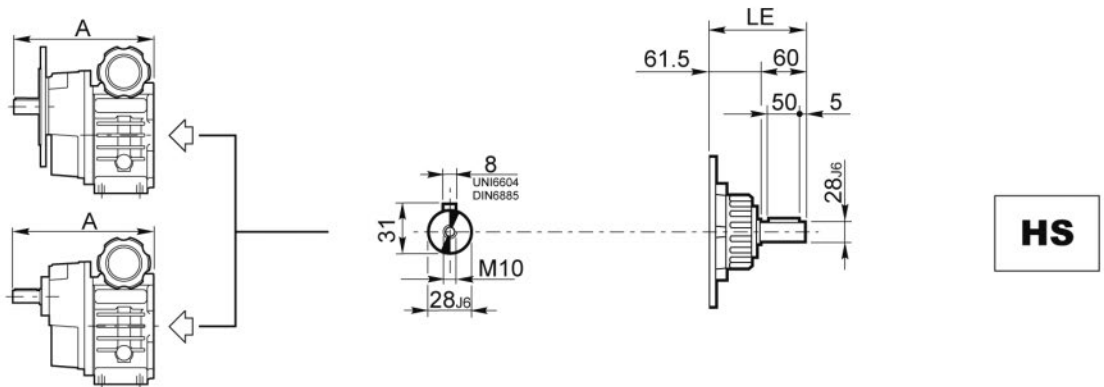

**VR 5.5 F\_**

**VR 5.5 U\_**  
**VR 5.5 P\_**

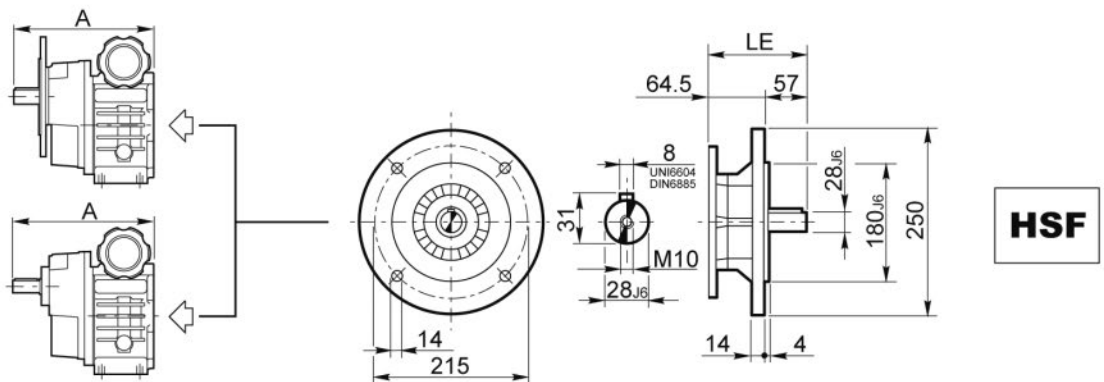

		AC	AD	LB	A+LB	Kg		
					D28	U	P	F
VR 5.5_P112	BN112_	219	157	325	682	88	93	88

	LE	A+LE	LM	A+LM	Kg		
		D38		D38	U	P	F
VR 5.5_HS	121.5	478.5	—	—	65	70	65
VR 5.5_HSF	121.5	478.5	—	—	69	74	69

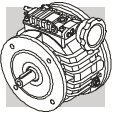

# V 10

**V 10 F\_P132**

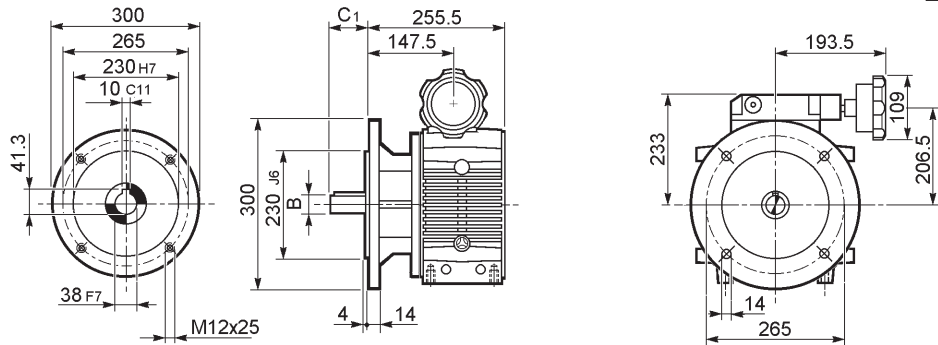

**V 10 U\_P132**

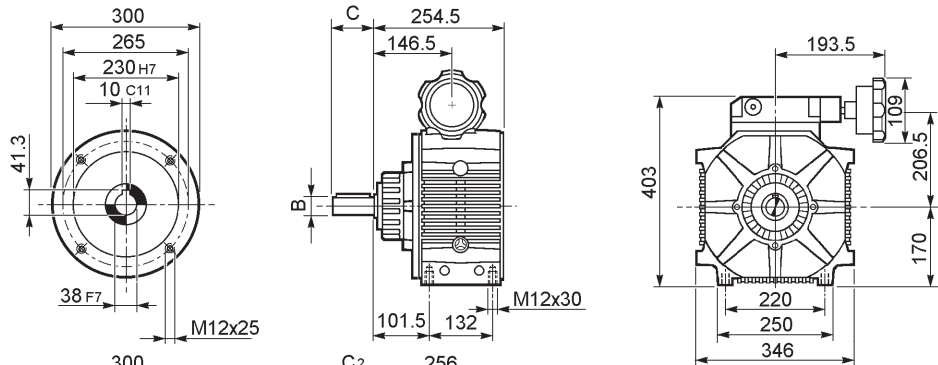

**V 10 UF\_P132**

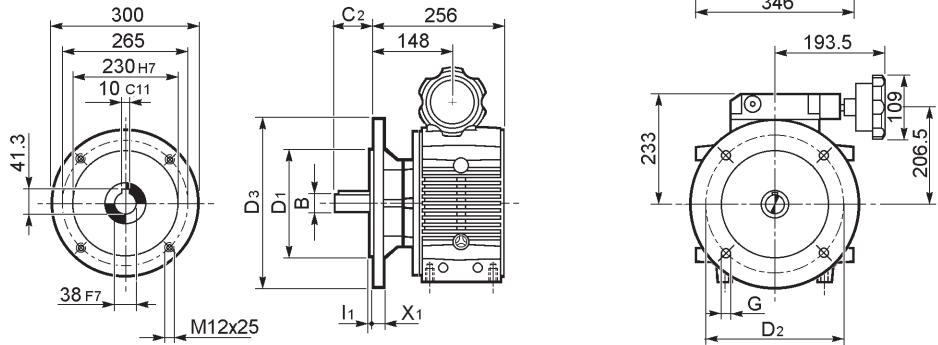

**V 10 UP\_P132**

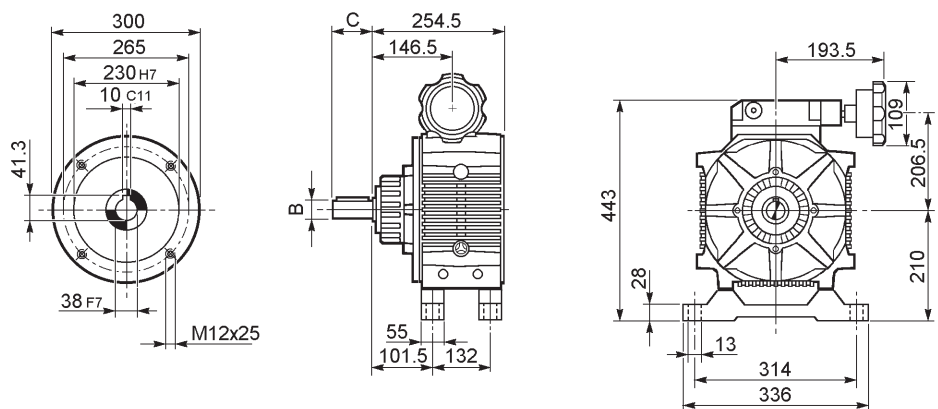

F-U-UF-UP	B j6	B1	B2	B3	B4	C	C1	C2	U
V 10_D38	38	41	10	5	70	80	79	78.5	M12
V 10_D42 *	42	45	12	10	90	110	109	108.5	M16

\* Non previsto nella esecuzione con differenziale; se richiesto, consultare il ns. Servizio tecnico commerciale.

\* Not available on versions featuring the differential unit. If required, please contact our Technical Service Dept.

\* Nicht in der Ausführung mit Differential vorgesehen. Wenn diese Einbaulage benötigt wird, informieren Sie sich bitte bei unserem technischen Kundendienst.

\* Non prévu sur la version avec différentiel; pour toute demande, consulter notre Service Après-Vente.

UF	D1 j6	D2	D3	G	I1	X1	Kg				
V 10 UF132_	230	265	300	14	4	16	V 10_P132	F	U	UF	UP
V 10 UF160_	250	300	350	18	5	15		97	88	97	96

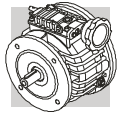

**V 10 F\_P132**

**V 10 U\_P132**

**V 10 UF\_P132**

**V 10 UP\_P132**

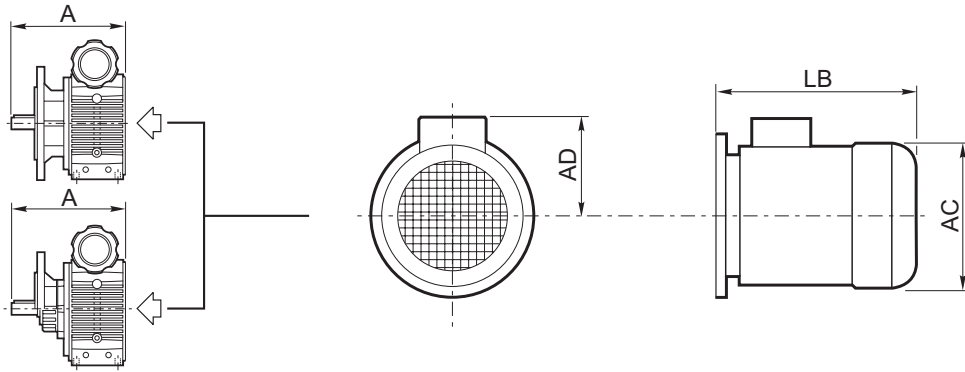

**BN**

**V 10 F\_**

**V 10 U\_**

**V 10 UF\_**

**V 10 UP\_**

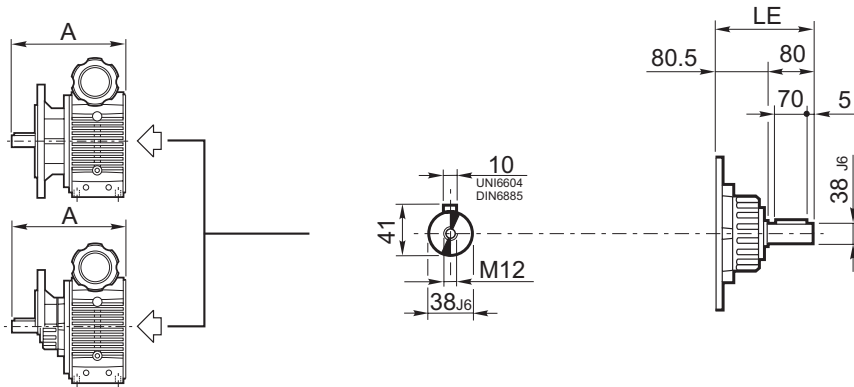

**HS**

**V 10 F\_**

**V 10 U\_**

**V 10 UF\_**

**V 10 UP\_**

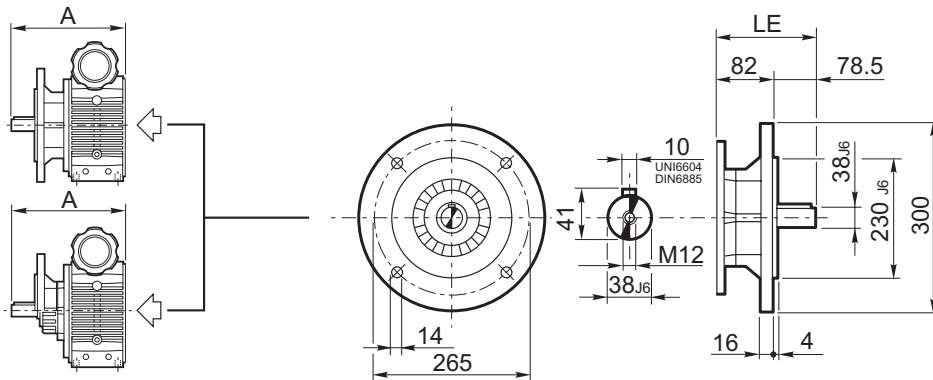

**HSF**

		AC	AD	LB	A+LB		Kg			
					D38	D42	F	U	UF	UP
V 10_P132	BN132S_	258	193	375	709.5	739.5	140	131	140	139
	BN132M_	258	193	413	747.5	777.5	155	146	155	154

	LE	A+LE		LM	A+LM		Kg			
		D38	D42		D38	D42	F	U	UF	UP
V 10_HS	160.5	495	525	—	—	—	108	99	108	107
V 10_HSF	160.5	495	525	—	—	—	117	108	117	116

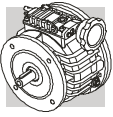

# VR 10

**VR 10 U\_P132**

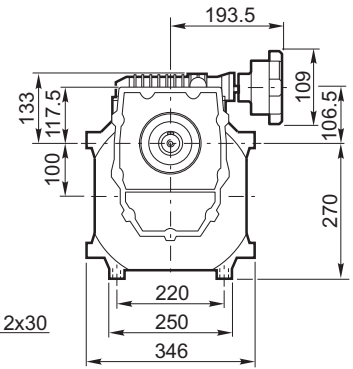
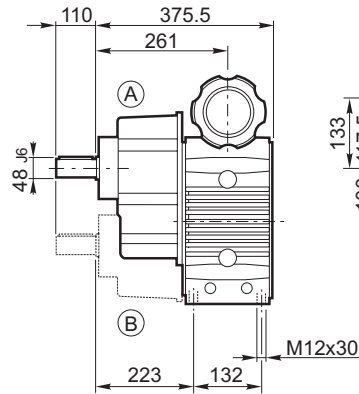
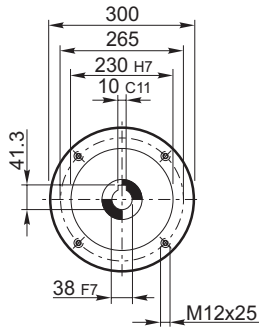

**VR 10 P\_P132**

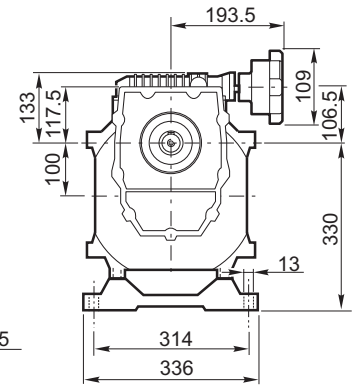
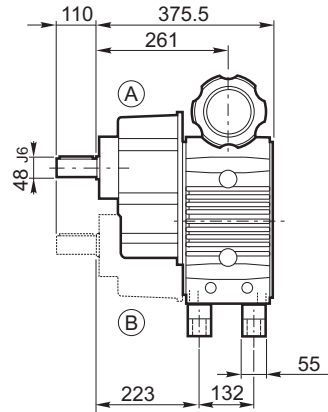
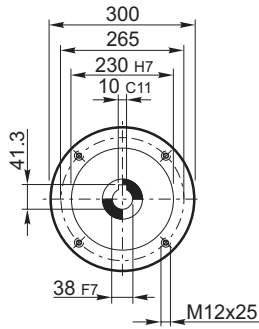

**VR 10 F\_P132**

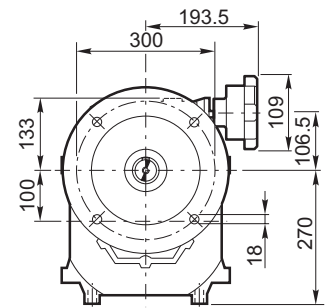
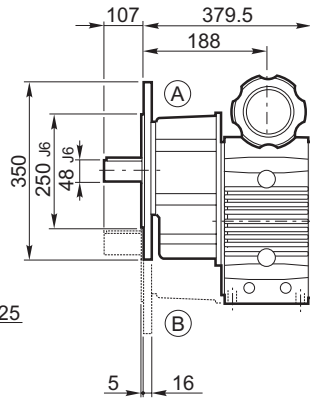
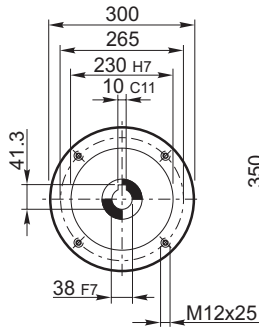

U-P-F	B j6	B1	B2	B3	B4	C	U
VR 10	48	52.5	14	10	90	110 (P) 107 (F)	M16

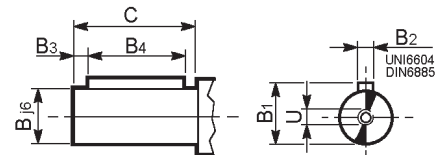

	Kg		
	U	P	F
VR 10_P132	117	125	117

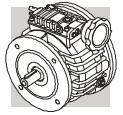

**VR 10 U\_P132**  
**VR 10 P\_P132**  
**VR 10 F\_P132**

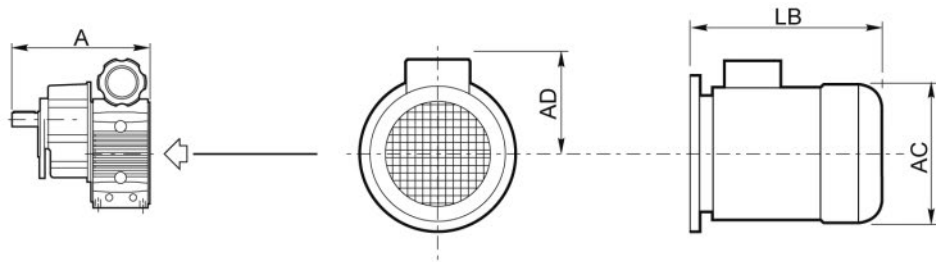

**BN**

**VR 10 U\_**  
**VR 10 P\_**  
**VR 10 F\_**

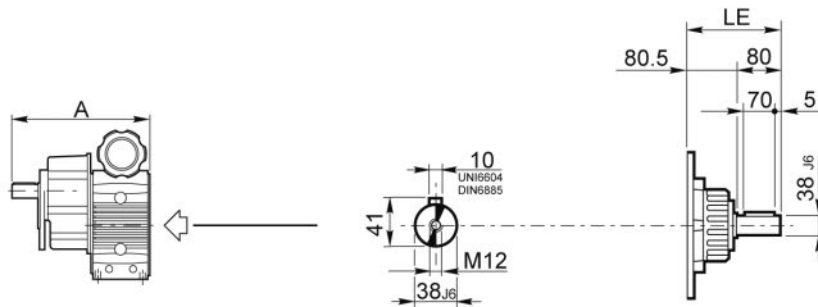

**HS**

**VR 10 U\_**  
**VR 10 P\_**  
**VR 10 F\_**

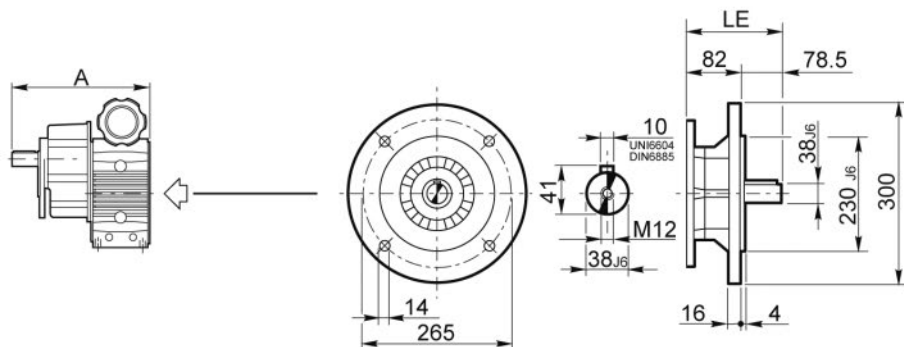

**HSF**

		AC	AD	LB	A+LB	Kg		
					D48	U	P	F
VR 10_P132	BN132S_	258	193	375	861	160	168	160
	BN132M_	258	193	413	899	175	183	175

	LE	A+LE	LM	A+LM	Kg		
		D48		D48	U	P	F
VR 10_HS	160.5	646.5	—	—	128	136	128
VR 10_HSF	160.5	646.5			137	145	137

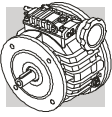

# VD

**VD\_F\_P (IEC)**

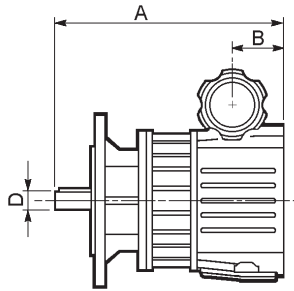

**VD\_U\_P (IEC)**  
**VD\_UF\_P (IEC)**  
**VD\_UP\_P (IEC)**

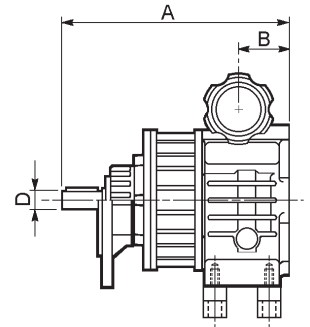

N.B. Le dimensioni mancanti sono riportate nelle pagine 50-81.

Note: missing dimensions are indicated on pages 50-81.

ACHTUNG: Die fehlenden Maße werden auf den Seiten 50-81 angegeben.

N.B. : Les dimensions manquantes sont indiquées pages 50-81.

	D	B	F		UP		UF		UPF	
			A	Kg	A	Kg	A	Kg	A	Kg
VD 0.5_P71	14	47.5	—	—	210	10.5	210	10.6	210	10.8
	19		—	—	220		220			
VD 1_P80	19	62	—	—	257.5	18.6	257.5	18.8	257.5	19.1
	24		—	—	267.5		267.5			
VD 2_P90	24	74.1	—	—	300.5	26	300.5	27	300.5	30
	28		—	—	310.5		310.5			
	D	B	F		U		UF		UP	
	D	B	A	Kg	A	Kg	A	Kg	A	Kg
VD 3_P100/112	28	91	373.4	55.	373.4	57	373.4	61	373.4	62
VD 5.5_P112	28	91	373.4	56	373.4	58	373.4	62	373.4	63
VD 10_P132	38	108	453.7	125	453.7	116	453.7	125	453.7	124

**VD\_F\_P(IEC)**

**VD\_U\_P(IEC)**

**VD\_UF\_P(IEC)**

**VD\_UP\_P(IEC)**

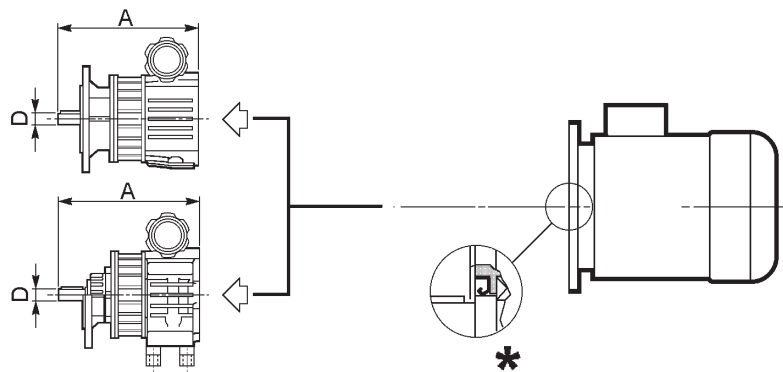

\* Nei variatori con differenziale, quando il motore elettrico è installato dall'utente, è necessario verificare che esso sia dotato di un anello di tenuta olio sull'albero montato secondo lo schema e che la flangia sia stagna.

La tenuta olio fra la flangia motore e la flangia variatore è assicurata da una guarnizione fornita di serie sul variatore stesso.

N.B. Le dimensioni e i pesi dei motori elettrici sono riportati nelle pag. 338-356.

\* Ou fitting the electric motor onto variators featuring the differential unit make sure that the electric motor itself is oiltight and an oil seal is provided on drive end shaft.

Sealing between flange of motor and variator is ensured by a gasket provided with the variator unit.

N.B. Dims and weights of electric motors are shown at page 338-356.

\* Wenn der Elektromotor vom Kunden angebaut wird, ist es bei den Verstellgetrieben mit Differential erforderlich, die Motorwelle mit einem öldichten Wellendichtring auszustatten.

Die Abdichtung zwischen Motor- und Verstelltriebeflansch wird durch eine Dichtung gewährleistet, die beim Verstellgetriebe serienmäßig mitgeliefert wird.

ACHTUNG: Die Maße und Gewichte der Elektromotoren werden auf den Seiten 338-356 aufgeführt.

\* Sur les variateurs avec différentiel, lorsque le moteur électrique est installé par l'utilisateur, il est nécessaire de vérifier qu'il soit doté d'une bague d'étanchéité sur l'arbre monté selon le schéma.

L'étanchéité à l'huile entre la bride moteur et la bride variateur est assurée par un joint fourni de série et présent sur le variateur.

N.B. : Les dimensions et les poids des moteurs électriques sont indiqués pages 338-356.



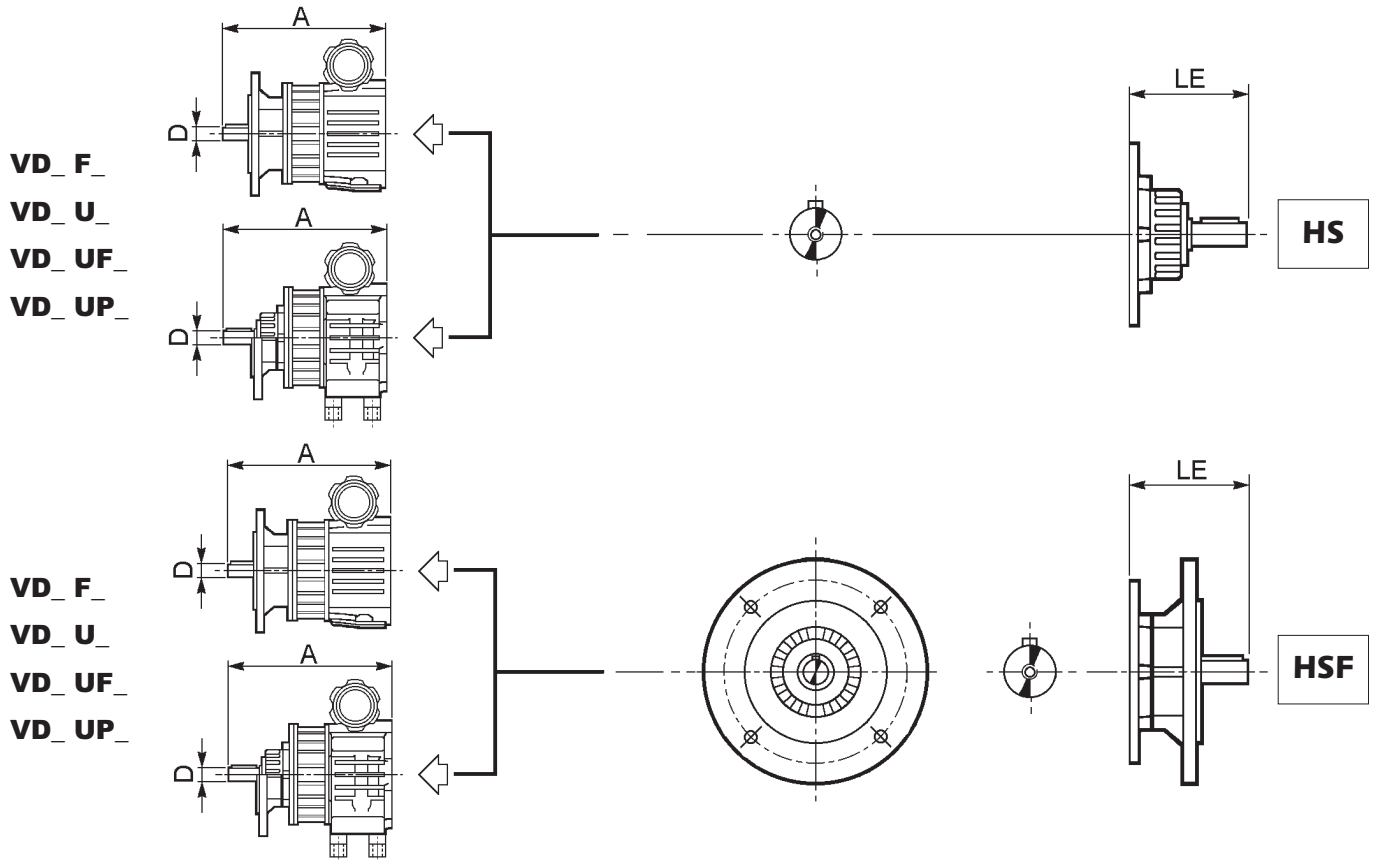
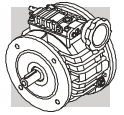

		D	LE	A+LE	LM	A+LM	Kg			
							F	UP	UF	UPF
VD 0.5_	HS/HSF	14	67	277	—	—	—	12.1 / 13.0	12.2 / 13.1	12.4 / 13.3
		19		287						
VD 1_		19	88.5	346	—	—	—	21.4 / 23.1	21.6 / 23.3	21.9 / 23.6
		24		356						
VD 2_		24	103.5	404	—	—	—	30 / 32	31 / 33	31 / 33
		28		414						
		D	LE	A+LE	LM	A+LM	Kg			
							F	U	UF	UP
VD 3_	HS/HSF	28	121.5	494.9	—	—	62 / 66	64 / 68	68 / 72	69 / 73
VD 5.5_		28	121.5	494.9	—	—	63 / 67	65 / 69	69 / 73	70 / 74
VD 10_		38	160.5	614.2	—	—	135 / 145	126 / 136	138 / 145	135 / 144

N.B. Le dimensioni mancanti sono riportate nelle pagine 50-81.

Note: missing dims are indicated on pages 50-81.

ACHTUNG: Die fehlenden Maße werden auf den Seiten 50-81 angegeben.

N.B. : Les dimensions manquantes sont indiquées pages 50-81.

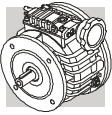

# VRD

**VRD\_F\_P (IEC)**  
**VRD\_U\_P (IEC)**

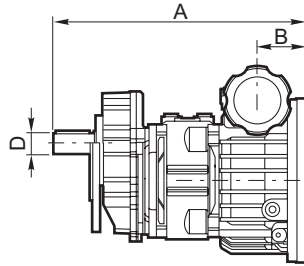

**VRD\_P\_P (IEC)**

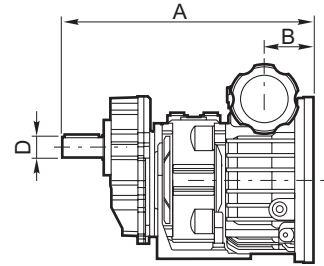

N.B. Le dimensioni mancanti sono riportate nelle pagine 50-81.

*Note: missing dimensions are indicated on pages 50-81.*

ACHTUNG: Die fehlenden Maße werden auf den Seiten 50-81 angegeben.

*N.B. : Les dimensions manquantes sont indiquées pages 50-81.*

	D	B	F		U		P	
			A	Kg	A	Kg	A	Kg
<b>VRD 0.5_P71</b>	19	47.5	277	13.4	277	12.6	277	13.3
<b>VRD 1_P80</b>	24	62	313.5	22	313.5	21	313.5	22
<b>VRD 2_P90</b>	28	74.1	373.5	33	373.5	31	373.5	33
<b>VRD 3_P100/112</b>	38	91	457.4	71	457.4	71	457.4	—
<b>VRD 5.5_P112</b>	38	91	457.4	74	457.4	74	457.4	—
<b>VRD 10_P132</b>	48	108	605.2	145	605.2	145	605.2	—

**VRD\_P\_P (IEC)**

**VRD\_F\_P (IEC)**

**VRD\_U\_P (IEC)**

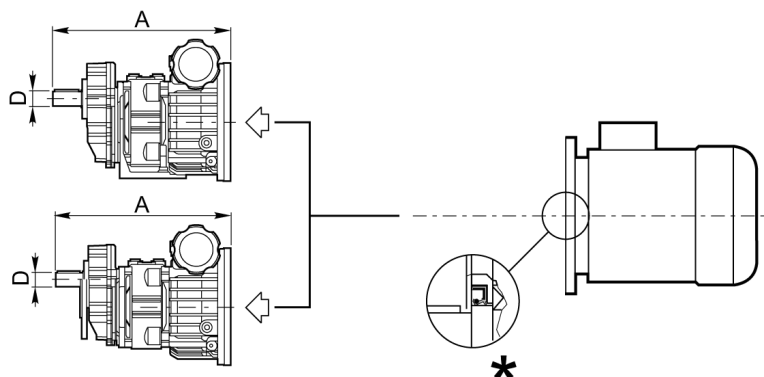

\* Nei variatori con differenziale, quando il motore elettrico è installato dall'utente, è necessario verificare che esso sia dotato di un anello di tenuta olio sull'albero montato secondo lo schema e che la flangia sia stagna.

La tenuta olio fra la flangia motore e la flangia variatore è assicurata da una guarnizione fornita di serie sul variatore stesso.

N.B. Le dimensioni e i pesi dei motori elettrici sono riportati nelle pag. 338-356.

*\* Ou fitting the electric motor onto variators featuring the differential unit make sure that the electric motor itself is oiltight and an oil seal is provided on drive end shaft.*

*Sealing between flange of motor and variator is ensured by a gasket provided with the variator unit.*

*N.B. Dimensions and weights of electric motors are listed at page 338-356.*

\* Wenn der Elektromotor vom Kunden angebaut wird, ist es bei den Verstellgetrieben mit Differential erforderlich, die Motorwelle mit einem öldichten Wellendichtring auszustatten.

Die Abdichtung zwischen Motor- und Verstelltriebflansch wird durch eine Dichtung gewährleistet, die beim Verstellgetriebe serienmäßig mitgeliefert wird.

ACHTUNG: Die Maße und Gewichte der Elektromotoren werden auf den Seiten 338-356 aufgeführt.

*\* Sur les variateurs avec différentiel, lorsque le moteur électrique est installé par l'utilisateur, il est nécessaire de vérifier qu'il soit doté d'une bague d'étanchéité sur l'arbre monté selon le schéma.*

*L'étanchéité à l'huile entre la bride moteur et la bride variateur est assurée par un joint fourni de série et présent sur le variateur.*

*N.B. : Les dimensions et les poids des moteurs électriques sont indiqués pages 338-356.*

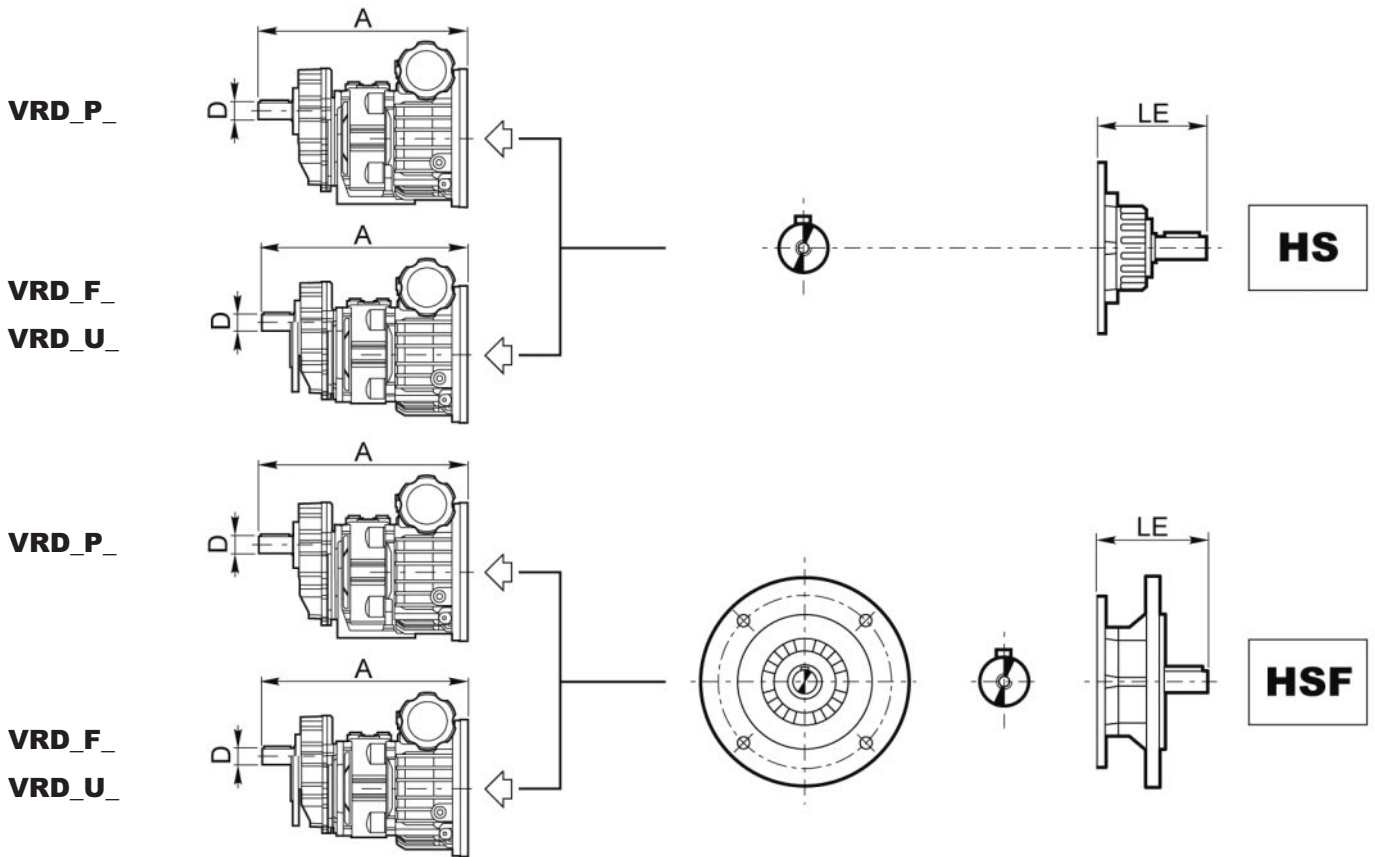
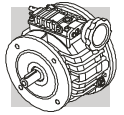

	D	LE	A+LE	LM	A+LM	Kg			
						F	U	P	
VRD 0.5_	HS/HSF	19	67	344	—	—	15.0/16.9	14.2/15.1	14.9/15.8
VRD 1_		24	88.5	402	—	—	25/27	24/26	25/27
VRD 2_		28	103.5	477	—	—	37/39	35/37	37/39
VRD 3_		38	121.5	578.9	—	—	78/82	—	78/82
VRD 5.5_		38	121.5	578.9	—	—	81/85	—	81/85
VRD 10_		48	160.5	765.7	—	—	156/165	—	156/165

N.B. Le dimensioni mancanti sono riportate nelle pagine 50-81.

Note: missing dimensions are indicated on pages 50-81.

ACHTUNG: Die fehlenden Maße werden auf den Seiten 50-81 angegeben.

N.B. : Les dimensions manquantes sont indiquées pages 50-81.

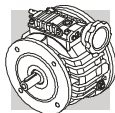

## 19.0 - VARIATORI V CON MOTORE A STANDARD NEMA

### Designazione

Vedi pag. 24.

### Tipi di comando

Ai variatori V tipo Nema possono essere applicati i seguenti comandi:

- Volantino di comando
- VG
- A - VA - VAG
- ECT (solo nella versione a 60Hz)

Ulteriori informazioni relative ai comandi indicati sono riportate a pag. 30.

### Opzioni

I variatori V tipo Nema dispongono delle stesse opzioni dei variatori standard:

- CU - FL
- PDN - PDP
- PV
- SO

Ulteriori informazioni relative alle opzioni sono riportate a pag. 28.

### Lubrificazione

Vedi pag. 36.

### Posizioni di montaggio

Vedi pag. 39.

### Accessori

I variatori V tipo Nema dispongono delle stesse opzioni dei variatori standard:

- CGY
- KIT CGY
- PIEDI
- INDGRAV
- FLANGE  
(flange disponibili solo con misure metriche)

Ulteriori informazioni relative agli accessori sono riportate a pag. 88.

## 19.0 - V VARIATORS WITH NEMA MOTORS

### Designation

See page 24.

### Speed control types

*Nema-specs V variators can be fitted with these controls:*

- *Speed control knob*
- *VG*
- *A - VA - VAG*
- *ECT (for 60 Hz supply only)*

*For more detailed information on speed controls, see page 30.*

### Options

*Available options for Nema-specs V variators are same as standard variators:*

- *CU - FL*
- *PDN - PDP*
- *PV*
- *SO*

*For more detailed information on options, see page 28.*

### Lubrication

See page 36.

### Mounting positions

See page 39.

### Accessories

*Available accessories for Nema-specs V variators are same as standard variators:*

- *CGY*
- *CGY KIT*
- *FEET*
- *INDGRAV*
- *FLANGED OUTPUTS*  
(available in metric sizes only)

*For more detailed information on accessories, see page 88.*

## 19.0 - VERSTELLGETRIEBE V GEMÄSS NEMA-NORMEN

### Bezeichnung

Siehe Seite 24.

### Verstelleinrichtungen

An den Verstellgetrieben V des Typs Nema können folgende Verstelleinrichtungen appliziert werden:

- Handstüerrad
- VG
- A - VA - VAG
- ECT (nur in der 60 Hz-Version)

Weitere Informationen bezüglich der angegebenen Verstelleinrichtungen finden Sie auf Seite 30.

### Optionen

Die Verstellgetriebe V des Typs Nema können mit den gleichen Optionen, die auch für die Standard-Verstellgetriebe verfügbar sind, ausgestattet werden.

- CU - FL
- PDN - PDP
- PV
- SO

Weitere Informationen bezüglich der angegebenen Verstelleinrichtungen finden Sie auf Seite 28.

### Schmierung

Siehe Seite 36.

### Montagelagen

Siehe Seite 39.

### Zubehör

Die Verstellgetriebe V des Typs Nema können mit dem gleichen Zubehör, das auch für die Standard-Verstellgetriebe verfügbar ist, ausgestattet werden.

- CGY
- KIT CGY
- FÜSSE
- INDGRAV
- FLANSCHEN  
(Flanschen nur in metrischen Maßen verfügbar)

Weitere Informationen bezüglich der angegebenen Verstelleinrichtungen finden Sie auf Seite 88.

## 19.0 - VARIATEURS V AVEC MOTEURS A NORMES NEMA

### Désignation

Voir page 24.

### Types de commande

*Sur les variateurs V type NEMA on peut monter les commandes suivantes:*

- *Volant de commande à main*
- *VG*
- *A - VA - VAG*
- *ECT (uniquement dans la version à 60 Hz)*

*Des informations complémentaires à l'égard de ces commandes se trouvent à page 30.*

### Options

*Les variateurs V type Nema ont les mêmes options que les variateurs V standard:*

- *CU - FL*
- *PDN - PDP*
- *PV*
- *SO*

*Des informations complémentaires à l'égard des options se trouvent à page 28.*

### Lubrification

Voir page 36.

### Positions de montage

Voir page 39.

### Accessoires

*Les variateurs V type Nema ont les mêmes options que les variateurs standard.*

- *CGY*
- *KIT CGY*
- *PATTES*
- *INDGRAV*
- *BRIDES*  
(brides disponibles uniquement avec mesures métriques)

*Des informations complémentaires à l'égard des accessoires se trouvent à page 88.*

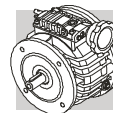



19.1 - Tabelle dati tecnici  
V Nema

19.1 Rating chart

19.1 - Tabellen technische  
daten

19.1 - Tableaux caractéristi-  
ques techniques

**V\_NEMA**

P <sub>1</sub> (kW/hp)	n <sub>2</sub>	n <sub>2</sub> '	n <sub>1</sub>	M <sub>2</sub>	M <sub>2</sub> '	Rn <sub>2</sub>	Rn <sub>2</sub> '		Flangia Nema Nema flange		
	rpm	rpm	rpm	in-lbs	in-lbs	Lbs	Lbs				
<b>0.18/0.25</b>	1100	230	1700	11.5	35.4	160	260	<b>V 025_</b>	<b>N56</b>	C	84-87
<b>0.25/0.33</b>	810	153	1100	23	71	230	400	<b>V 0.5_</b>	<b>N56</b>	C	84-87
	1100	230	1700	14.2	44	160	260	<b>V 0.25_</b>	<b>N56</b>	C	84-87
	2200	460	3400	8.0	23	130	215	<b>V 0.25_</b>	<b>N56</b>	C	84-87
<b>0.37/0.5</b>	810	153	1100	36	71	230	400	<b>V 0.5_</b>	<b>N56</b>	C	84-87
	1210	230	1700	22	71	200	350	<b>V 0.5_</b>	<b>N56</b>	C	84-87
	2200	460	3400	11.5	35	130	215	<b>V 0.25_</b>	<b>N56</b>	C	84-87
<b>0.55/0.75</b>	810	153	1100	50	142	320	500	<b>V 1_</b>	<b>N143T</b>	C	84-87
	1210	230	1700	36	106	200	340	<b>V 0.5_</b>	<b>N56</b>	C	84-87
	2420	460	3400	17.7	44	160	270	<b>V 0.5_</b>	<b>N56</b>	C	84-87
<b>0.75/1.1</b>	810	153	1100	68	142	320	550	<b>V 1_</b>	<b>N143T</b>	C	84-87
	1210	230	1700	45	142	280	480	<b>V 1_</b>	<b>N56</b>	C	84-87
	2420	460	3400	24	71	160	270	<b>V 0.5_</b>	<b>N56</b>	C	84-87
<b>1.1/1.5</b>	1210	230	1700	68	212	280	480	<b>V 1_</b>	<b>N143T</b>	C	84-87
	2420	460	3400	35	106	220	380	<b>V 1_</b>	<b>N143T</b>	C	84-87
<b>1.5/2</b>	1210	230	1700	89	283	370	635	<b>V 2_</b>	<b>N145T</b>	C	84-87
	2420	460	3400	45	142	220	380	<b>V 1_</b>	<b>N143T</b>	C	84-87
<b>2.2/3</b>	1210	230	1700	135	354	580	1000	<b>V 3_</b>	<b>N182T</b>	C	84-87
<b>4.0/5.5</b>	1210	230	1700	219	637	580	1000	<b>V 5.5_</b>	<b>N184T</b>	C	84-87
<b>5.5/7.5</b>	1210	230	1700	327	761	720	1260	<b>V 10_</b>	<b>N213T</b>	C	84-87
<b>7.5/10</b>	1210	230	1700	434	1026	720	1260	<b>V 10_</b>	<b>N213T</b>	C	84-87

Fattore di conversione:  
1 in-lbs = 0.11301 Nm

Conversion factor :  
1 in-lbs = 0.11301 Nm

Umrechnungsfaktor:  
1 in-lbs = 0,11301 Nm

Facteur de conversion:  
1 in-lbs = 0,11301 Nm

NB. :  
I carichi in uscita Rn<sub>2</sub> indicati in tabella sono da considerare applicati sulla mezzzeria dell'albero. Per carichi la cui linea d'azione non coincide con la mezzzeria dell'albero in esame, effettuare le verifiche riportate a pag. 8.

NOTE:  
Admissible overhung loads Rn<sub>2</sub> indicated in the table refer to mid-point of shaft. Where loads are applied at any other position of shaft, follow procedure detailed on page 8 to verify compatibility.

HINWEIS:  
Die in der Tabelle angegebenen Kräfte am Abtrieb Rn<sub>2</sub> sind als auf die Wellenmitte applizierte Kräfte zu kalkulieren. Für Kräfte, deren Wirkungslinie nicht mit der Mitte der zur Frage stehenden Welle übereinstimmt, sind die auf Seite 8 angeführten Kontrollen vorzunehmen. Hinweis.

N.B. :  
Il faut considérer les charges radiales en sortie Rn<sub>2</sub>, indiquées sur le tableau, comme appliquées au milieu de l'arbre. Pour les charges dont la ligne d'action ne coïncide pas avec le milieu de l'arbre concerné, effectuer les vérifications indiquées à page 8.

AVVERTENZA: Si sconsiglia l'utilizzo del variatore con velocità in ingresso inferiori a 300 min<sup>-1</sup>.

WARNING: Use of the variator with an input speed lower than 300 min<sup>-1</sup> is NOT recommended.

ACHTUNG: Wenn die Eingangsdrehzahl des Antriebs unter 300 min<sup>-1</sup> liegt, wird von der Verwendung des Verstellgetriebes abgeraten.

N.B. : Il n'est pas conseillé d'utiliser le variateur avec une vitesse en entrée inférieure à 300 min<sup>-1</sup>.

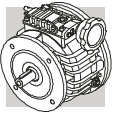

# V\_N

19.2 - Dimensioni V Nema

19.2 - Dimensions of Nema-specs V

19.2 - Maße - V Nema

19.2 - Dimensions V Nema

## V\_UP IMP\_N (V 0.25 - V 2)

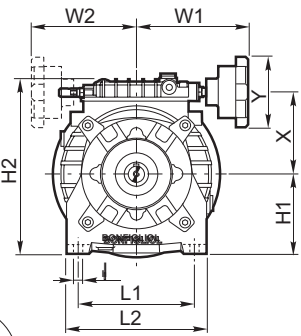
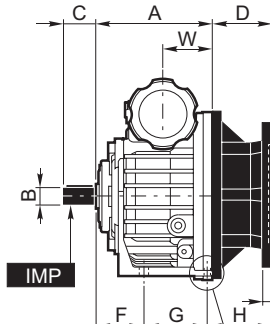
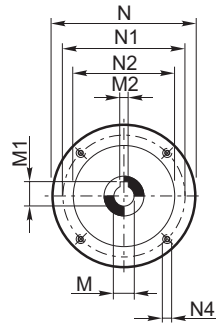

## V\_UF(Nema) IMP\_N (V 0.25 - V 2)

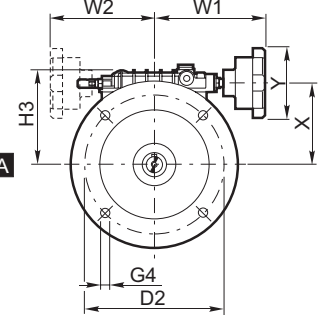
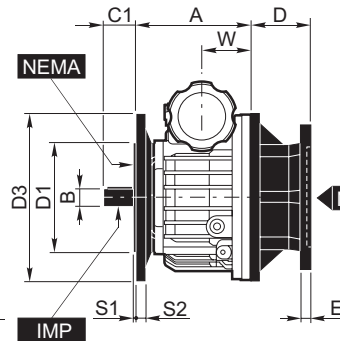
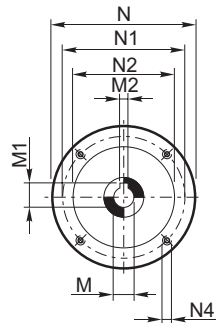

## V\_U IMP\_N (V 3 - V 10)

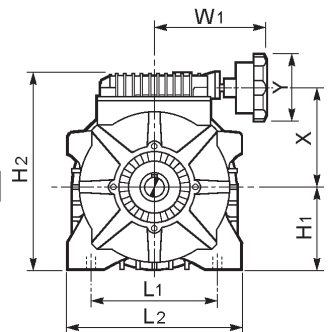
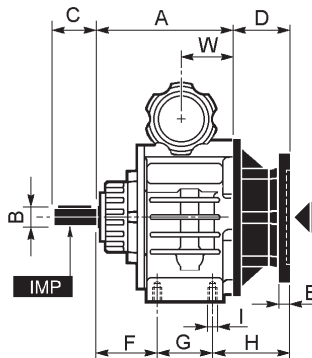
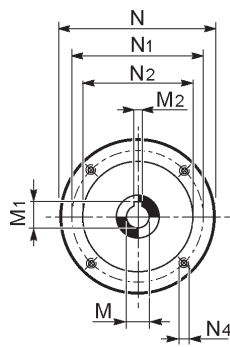

## V\_UF(Nema) IMP\_N (V 3 - V 10)

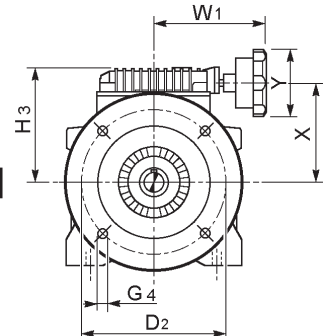
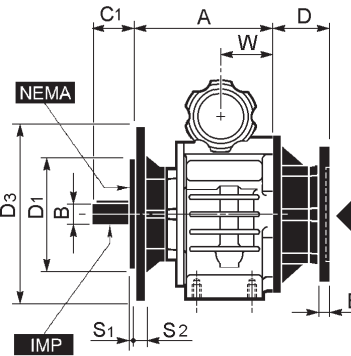
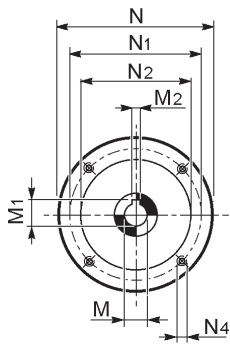

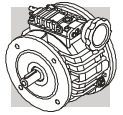

## V\_U IMP\_N - V\_UF(Nema) IMP\_N - V\_U\_N - V\_UF\_N

	N	N1	N2	N4	M	M1	M2	E
V 0.25_N56	6.496"	5.875"	4.5"	0.413"	0.625"	0.707"	0.19"	0.472"
V 0.5_N56	6.496"	5.875"	4.5"	0.413"	0.625"	0.707"	0.19"	0.512"
V 1_N56	6.496"	5.875"	4.5"	0.413"	0.625"	0.707"	0.19"	0.472"
V 1_N143T	6.496"	5.875"	4.5"	0.413"	0.875"	0.961"	0.19"	0.512"
V 2_N145T	6.496"	5.875"	4.5"	0.413"	0.875"	0.961"	0.19"	0.512"
V 3_N182T	8.898"	7.25"	8.5"	0.531"	1.125"	1.276"	0.252"	0.630"
V 5.5_N184T	8.898"	7.25"	8.5"	0.531"	1.125"	1.276"	0.252"	0.630"
V 10_N213T	8.898"	7.25"	8.5"	0.531"	1.375"	1.512"	0.314"	0.827"

## V U IMP - UF(Nema)\_IMP

	B j6	B1	B2	B4
V 0.25	0.625"	0.689"	0.187"	1.378"
V 0.5	0.625"	0.689"	0.187"	1.378"
V 1	0.625"	0.689"	0.187"	1.378"
V 2	0.875"	0.943"	0.187"	1.378"
V 3	1.125"	1.220"	0.25"	1.752"
V 5.5	1.125"	1.220"	0.25"	1.752"
V 10	1.375"	1.449"	0.312"	2.382"

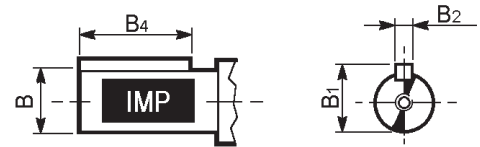

## V\_U

	A	C	D	F	G	H	H1	H2	I	L1	L2	P	Q	X	Y	W	W1	W2
V 0.25	4.272"	1.875"	2.322"	1.890"	2.028"	2.676"	2.756"	6.378"	0.354"	4.803"	5.787"	—	0.354"	2.756"	3.268"	1.772"	4.528"	4.331"
V 0.5	4.370"	1.875"	2.204"	1.850"	2.244"	2.480"	2.913"	6.850"	0.354"	4.331"	5.315"	0.197"	0.354"	3.071"	3.268"	1.870"	4.528"	4.331"
V 1	5.394"	1.875"	2.244"	2.146"	2.795"	2.697"	3.740"	8.425"	0.433"	5.433"	6.535"	0.276"	0.433"	3.819"	3.268"	2.441"	5.236"	4.882"
V 2	6.339"	2.25"	2.268"	2.461"	3.780"	2.366"	4.291"	9.606"	0.433"	6.457"	7.874"	0.315"	0.433"	4.449"	3.268"	2.917"	5.394"	4.724"
V 3	8.386"	2.75"	3.090"	3.031"	4.725"	3.720"	5.197"	12.008"	M12	7.874"	10.709"	—	—	5.925"	4.291"	3.582"	6.791"	—
V 5.5	8.386"	2.75"	3.090"	3.031"	4.725"	3.720"	5.197"	12.008"	M12	7.874"	10.709"	—	—	5.925"	4.291"	3.582"	6.791"	—
V 10	10.02"	3.375"	3.819"	3.996"	5.197"	4.646"	6.693"	15.866"	M12	8.661"	9.842"	—	—	8.13"	4.291"	4.252"	7.618"	—

## V\_UF(Nema)

	A	C1	D	D1	D2	D3	G4*	H3	S1	S2	X	Y	W	W1	W2
V 0.25 UF56C_	4.118"	2.029"	2.322"	4.5"	5.875"	6.496"	3/8"-16	3.622"	0.137"	0.512"	2.756"	3.268"	1.772"	4.528"	4.331"
V 0.5 UF56C_	4.177"	2.068"	2.204"	4.5"	5.875"	6.496"	3/8"-16	3.937"	0.137"	0.512"	3.071"	3.268"	1.870"	4.528"	4.331"
V 1 UF56C_	5.201"	2.068"	2.244"	4.5"	5.875"	6.496"	3/8"-16	4.685"	0.137"	0.512"	3.819"	3.268"	2.441"	5.236"	4.882"
V 2 UF145T_	6.458"	2.13"	2.268"	4.5"	5.875"	6.496"	3/8"-16	5.315"	0.137"	0.512"	4.449"	3.268"	2.917"	5.394"	4.724"
V 3 UF182T_	8.496"	2.64"	3.090"	8.5"	7.25"	8.898"	1/2"-13	6.811"	0.255"	0.531"	5.925"	4.291"	3.582"	6.791"	—
V 5.5 UF184T_	8.496"	2.64"	3.090"	8.5"	7.25"	8.898"	1/2"-13	6.811"	0.255"	0.531"	5.925"	4.291"	3.582"	6.791"	—
V 10 UF213T_	10.012"	3.383"	3.819"	8.5"	7.25"	8.898"	1/2"-13	9.179"	0.255"	0.787"	8.13"	4.291"	4.252"	7.618"	—

\* Filettatura serie "UNC" / Thread "UNC" series / Serienmäßiges Gewinde "UNC" / Filetage série "UNC"

\* Filettatura metrica "ISO" / "ISO" Metric thread / Metrisches Gewinde "ISO" / Filetage métrique "ISO"

Fattore di conversione / Conversion factor / Umrechnungsfaktor / Facteur de conversion: 1" = 25.4 mm

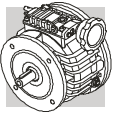

**V\_N**

**V\_UP\_N**  
(V 0.25 - V 2)

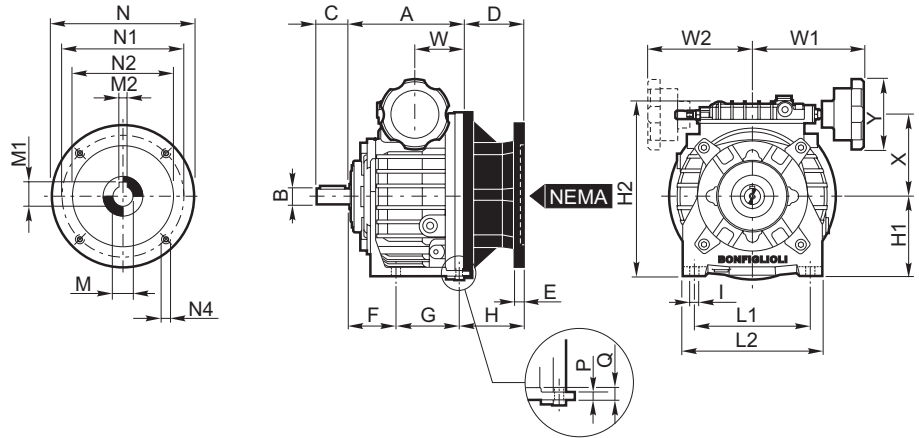

**V\_UF\_N**  
(V 0.25 - V 2)

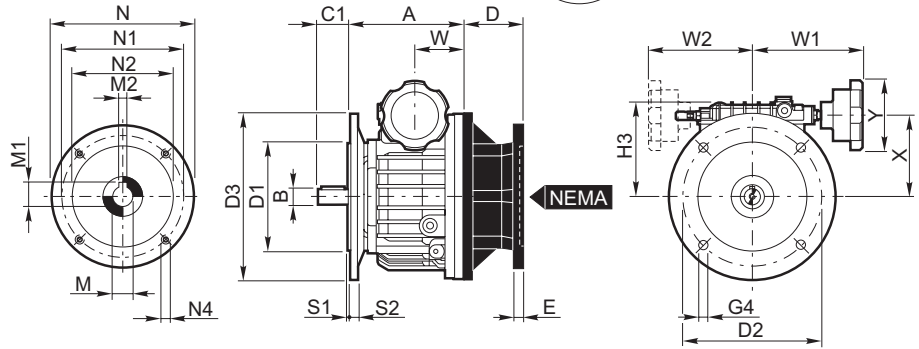

**V\_U\_N**  
(V 3 - V10)

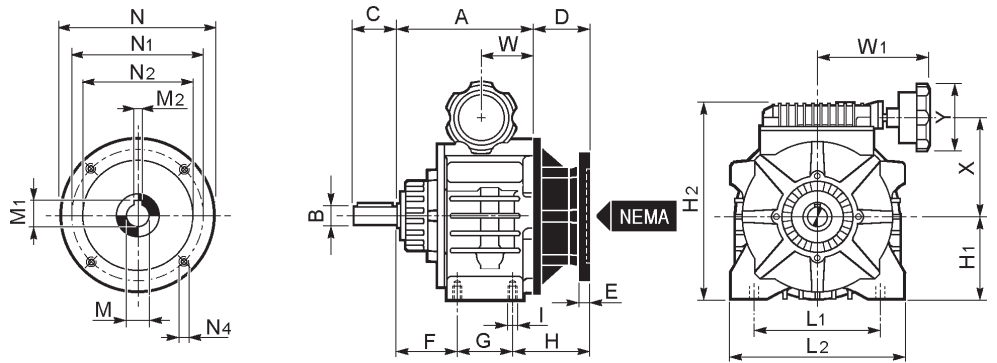

**V\_UF\_N**  
(V 3 - V10)

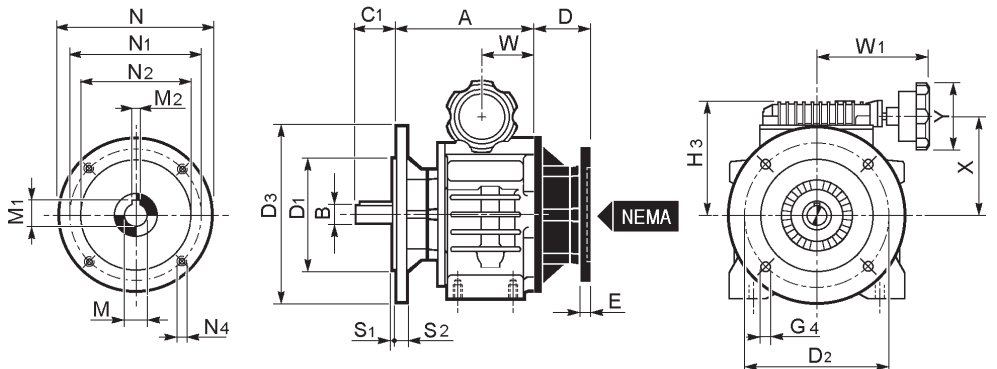



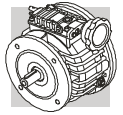

## V\_U IMP\_N - V\_UF(Nema) IMP\_N - V\_U\_N - V\_UF\_N

	N	N1	N2	N4	M	M1	M2	E
V 0.25_N56	6.496"	5.875"	4.5"	0.413"	0.625"	0.707"	0.19"	0.472"
V 0.5_N56	6.496"	5.875"	4.5"	0.413"	0.625"	0.707"	0.19"	0.512"
V 1_N56	6.496"	5.875"	4.5"	0.413"	0.625"	0.707"	0.19"	0.472"
V 1_N143T	6.496"	5.875"	4.5"	0.413"	0.875"	0.961"	0.19"	0.512"
V 2_N145T	6.496"	5.875"	4.5"	0.413"	0.875"	0.961"	0.19"	0.512"
V 3_N182T	8.898"	7.25"	8.5"	0.531"	1.125"	1.276"	0.252"	0.630"
V 5.5_N184T	8.898"	7.25"	8.5"	0.531"	1.125"	1.276"	0.252"	0.630"
V 10_N213T	8.898"	7.25"	8.5"	0.531"	1.375"	1.512"	0.314"	0.827"

## V\_U - UF

	B j6	B1	B2	B3	B4	C	C1	U
V 0.25_D11(D14)	11(14)	12.5(16)	4(5)	2.5(2.5)	18(25)	23(30)	—	M4(M5)
V 0.5_D14(D19)	14(19)	16(21.5)	5(6)	2.5(5)	25(30)	30(40)	—	M5(M6)
V 1_D19(D24)	19(24)	21.5(27)	6(8)	5(5)	30(40)	40(50)	—	M6(M8)
V 2_D24(D28)	24(28)	27(31)	8(8)	5(5)	40(50)	50(60)	—	M8(M10)
V 3_D28(D38)	28(38)	31(41)	8(10)	5(5)	50(70)	60(80)	58(78)	M10(M12)
V 5.5_D28(D38)	28(38)	31(41)	8(10)	5(5)	50(70)	60(80)	58(78)	M10(M12)
V 10_D38(D42)	38(42)	41(45)	10(12)	5(10)	70(90)	80(110)	78.5(108.5)	M12(M16)

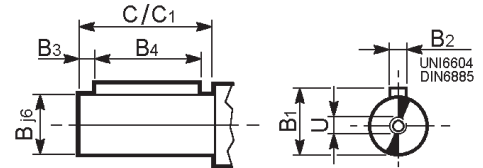

## V\_U

	A	D	F	G	H	H1	H2	I	L1	L2	P	Q	X	Y	W	W1	W2
V 0.25	108.5	60	48	51.5	68	70	162	9	122	147	—	9	70	83	45	115	110
V 0.5	111	56	47	57	63	74	174	9	110	135	5	9	78	83	47.5	115	110
V 1	137	57	54.5	71	68.5	95	214	11	138	166	7	11	97	83	62	133	124
V 2	161	57.6	62.5	96	60.1	109	244	11	164	200	8	11	113	83	74.1	137	120
V 3	213	78.5	77	120	94.5	132	305	M12x22	200	272	—	—	150.5	109	91	172.5	—
V 5.5	213	78.5	77	120	94.5	132	305	M12x22	200	272	—	—	150.5	109	91	172.5	—
V 10	254.5	97	101.5	132	118	170	403	M12x30	220	250	—	—	206.5	109	108	193.5	—

## V\_UF

	A	D1j6	D	D2	D3	G4	H3	S1	S2	X	Y	W	W1	W2
V 0.25 UF63_	108.5	95	60	115	140	9	92	3	8	70	83	45	115	110
V 0.25 UF71_	108.5	110	60	130	160	9	92	3.5	8	70	83	45	115	110
V 0.5 UF71_	111	110	56	130	160	9	100	3.5	8	78	83	47.5	115	110
V 0.5 UF80_	111	130	56	165	200	11.5	100	3.5	10	78	83	47.5	115	110
V 1 UF80_	137	130	57	165	200	11.5	119	3.5	10	97	83	62	133	124
V 1 UF90_	137	130	57	165	200	11.5	119	3.5	10	97	83	62	133	124
V 2 UF90_	161	130	57.6	165	200	11.5	135	3.5	12	113	83	74.1	137	120
V 2 UF100_	161	180	57.6	215	250	14	135	4	14	113	83	74.1	137	120
V 3 UF100_	215	180	78.5	215	250	14	173	4	14	150.5	109	91	172.5	—
V 3 UF132_	215	230	78.5	265	300	14	173	4	14	150.5	109	91	172.5	—
V 5.5 UF112	215	180	78.5	215	250	14	173	4	14	150.5	109	91	172.5	—
V 5.5 UF132_	215	230	78.5	265	300	14	173	4	14	150.5	109	91	172.5	—
V 10 UF132_	256	230	97	265	300	14	233	4	16	206.5	109	108	193.5	—
V 10 UF160_	256	250	97	300	350	18	233	5	15	206.5	109	108	193.5	—

Fattore di conversione / Conversion factor / Umrechnungsfaktor / Facteur de conversion: 1 mm = 0.0394"

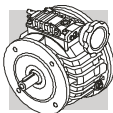

## 20.0 - ACCESSORI

### Indicatore di giri digitale CGY

È un indicatore programmabile (a microcontrollore) che rileva segnali provenienti da sonde amplificate NPN, PNP, NAMUR e se collegato al variatore configurato con opzione PDN o PNP (par. 18.4) consente la visualizzazione diretta del numero di giri in uscita al variatore o ne permette eventuali trasformazioni.

#### Caratteristiche tecniche:

- contenitore da pannello 96x48x100
- morsettiere estraibili
- dima di foratura 92.3X44.5 mm
- scatola in pvc nero DIN43700
- display a 6 cifre ad alta efficienza
- tastiera interna di programmazione
- menù di programmazione guidato
- scale e risoluzioni programmabili
- protezione dei programmi
- alimentazione (da specificare in fase di ordine):  
110V-50/60 Hz  
220V-50/60 Hz

#### Funzionamento:

Tramite un menù di programmazione guidato (tastiera di programmazione interna al pannello frontale) è possibile ottenere:

- visualizzazione diretta del numero di giri in uscita al variatore;
- visualizzazione della velocità in uscita ad un riduttore posto a valle del variatore
- visualizzazione di valori derivanti da conversioni in varie unità di misura (Kg/min, litri/min, metri/min)

#### Esempi di programmazione:

##### 1) Visualizzazione dei giri in uscita al variatore.

Numero fori della ruota fonica  $nf=10$ .  
Impostare nel menù di programmazione i seguenti valori:  
 $n=10, U=1, S=1, r=4, d=1, t=1, F=0, a=0, u=0, E=0$ .

##### 2) Visualizzazione dei giri in uscita a un riduttore accoppiato al variatore.

Numero fori della ruota fonica  $nf=10$ .  
Rapporto di riduzione del riduttore  $i=36.82$ .  
Impostare nel menù di programmazione i seguenti valori:  
 $n=10 \times 36.82 = 368.2 = 368$  (introdurre solo numeri interi),  
 $U=1, S=1, r=4, d=1, t=1, F=0, a=0, u=0, E=0$ .

## 20.0 - ACCESSORIES

### Indicatore di giri digitale CGY

*It is a programmable indicator (on microprocessor) which detects signals from amplified probes NPN, PNP and NAMUR and, if connected to the variator preset for PDN or PNP option (par. 18.4), it allows the variator output rpms to be directly displayed or allows possible conversions.*

#### Technical features:

- panel container 96x48x100
- removable terminal boards
- template 92.3X44.5 mm
- black PVC box according to DIN43700
- hi-efficiency 6-digit display
- inner programming keypad
- guided programming menu
- programmable scales and resolutions
- program protections
- power supply (specify when placing the order):  
110V-50/60 Hz  
220V-50/60 Hz

#### Operation:

*The following can be displayed through a guided programming menu (front panel inner programming keypad):*

- direct display of the variator output rpms;
- display of output rpms of a gearbox downstream the variator
- display of values after conversion into different measurement units (Kg/min, liters/min. and meters/min).

#### Programming examples:

##### 1) Display of variator output rpms

*Number of holes in the phonic wheel  $nf=10$ .  
Set the following values in the programming menu:  
 $n=10, U=1, S=1, r=4, d=1, t=1, F=0, a=0, u=0, E=0$ .*

##### 2) Display of output rpms of a gearbox downstream the variator.

*Number of holes in the phonic wheel  $nf=10$ .  
Gearbox reduction ratio  $i=36.82$ .  
Set the following values in the programming menu:  
 $n=10 \times 36.82 = 368.2 = 368$  (enter only integers),  
 $U=1, S=1, r=4, d=1, t=1, F=0, a=0, u=0, E=0$ .*

## 20.0 - ZUBEHÖR

### Digitale Drehzahlanzeige CGY

Hierbei handelt es sich um eine programmierbare Anzeigevorrichtung (mit Mikrosteuerbaustein), die die von den NPN- PNP- oder NAMUR-Sonden ausgehenden Signale erfaßt. Wenn sie an einem Verstellgetriebe, dessen Konfiguration die Option PDN oder PNP (Par. 18.4) aufweist, angeschlossen wird, ermöglicht sie die direkte Anzeige der Umdrehungszahl am Abtrieb des Verstellgetriebes und erlaubt eventuelle Umformungen.

#### Technische Eigenschaften:

- Behälter für Platte 96 x 48x100
- Ausziehbare Klemmenleisten
- Bohrungsschablone 92.3X44.5 mm
- Gehäuse aus schwarzem PVC DIN43700
- Hochleistungsfähiges sechsstelliges Display
- Interne Programmierastatur
- Geführtes Programmiermenü
- Programmierbare Skalen und Auflösungen
- Programmschutz
- Anschluß (muß im Auftrag spez. fiziert werden):  
110V-50/60 Hz  
220V-50/60 Hz

#### Betrieb:

Mittels eines geführten Programmiermenüs (die Programmierastatur befindet sich in der Fronttafel) sind die Angabe folgender Anzeigen möglich:

- Abtriebsdrehzahl des Verstellgetriebes;
- Geschwindigkeit am Abtrieb eines Getriebes, das dem Verstellgetriebe nachgeschaltet ist;
- Werte, die sich aus Umrechnungen in verschiedene Maßeinheiten (kg/Min, Liter/Min, Meter/Min) ergeben.

#### Programmierbeispiele:

##### 1) Anzeige der Drehzahl am Abtrieb des Verstellgetriebes.

Anzahl der Bohrungen des Impulsgebers  $nf=10$ .  
Im Programmiermenü folgende Werte einstellen:  
 $n=10, U=1, S=1, r=4, d=1, t=1, F=0, a=0, u=0, E=0$ .

##### 2) Anzeige der Drehzahl am Abtrieb eines dem Verstellgetriebe

nachgeschalteten Untersetzungsgetriebes.  
Anzahl der Bohrungen des Impulsgebers  $nf=10$ .  
Untersetzung des nachfolgenden Getriebe  $i=36.82$ .  
Im Programmiermenü folgende Werte einstellen:  
 $n=10 \times 36.82 = 368.2 = 368$  (nur ganze Zahlen eingeben),  
 $U=1, S=1, r=4, d=1, t=1, F=0, a=0, u=0, E=0$ .

## 20.0 - ACCESSOIRES

### Indicateur de tours digital CGY

*Il s'agit d'un indicateur programmable (à microcontrôleur) qui détecte les signaux provenant de sondes amplifiées NPN, PNP, NAMUR et, lorsqu'il est relié au variateur configuré avec l'option PDN ou PNP (par.18.4), il permet l'affichage direct du nombre de tours en sortie du variateur ou en permet d'éventuelles transformations.*

#### Caractéristiques techniques :

- Boîtier de panneau 96x48x100
- Borniers amovibles
- Gabarit de perçage 92.3X44.5 mm
- Boîte en PVC noir DIN43700
- Afficheur à 6 chiffres à performance élevée
- Clavier de programmation interne
- Menu de programmation guidé
- Echelles et résolutions programmables
- Protection des programmes
- Alimentation (à spécifier au moment de la commande) :  
110V-50/60 Hz  
220V-50/60 Hz

#### Fonctionnement :

*A l'aide d'un menu de programmation guidé (clavier de programmation à l'intérieur du panneau frontal), il est possible d'obtenir :*

- l'affichage direct du nombre de tours en sortie du variateur;
- l'affichage de la vitesse en sortie d'un réducteur situé à aval du variateur;
- l'affichage des valeurs dérivant de conversions dans différentes unités de mesure (Kg/min, litres/min, mètre/min).

#### Exemples de programmation :

##### 1) Affichage des tours en sortie du variateur.

*Nombre d'encoches de la roue phonique  $nf=10$ .  
Dans le menu de programmation, programmer les valeurs suivantes :  
 $n=10, U=1, S=1, r=4, d=1, t=1, F=0, a=0, u=0, E=0$ .*

##### 2) Affichage des tours en sortie d'un réducteur en aval du variateur.

*Nombre d'encoches de la roue phonique  $nf=10$ .  
Rapport de réduction du réducteur  $i=36.82$ .  
Dans le menu de programmation, programmer les valeurs suivantes :  
 $n=10 \times 36.82 = 368.2 = 368$  (introduire uniquement des nombres entiers),  
 $U=1, S=1, r=4, d=1, t=1, F=0, a=0, u=0, E=0$ .*

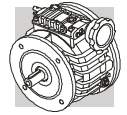

(C12)

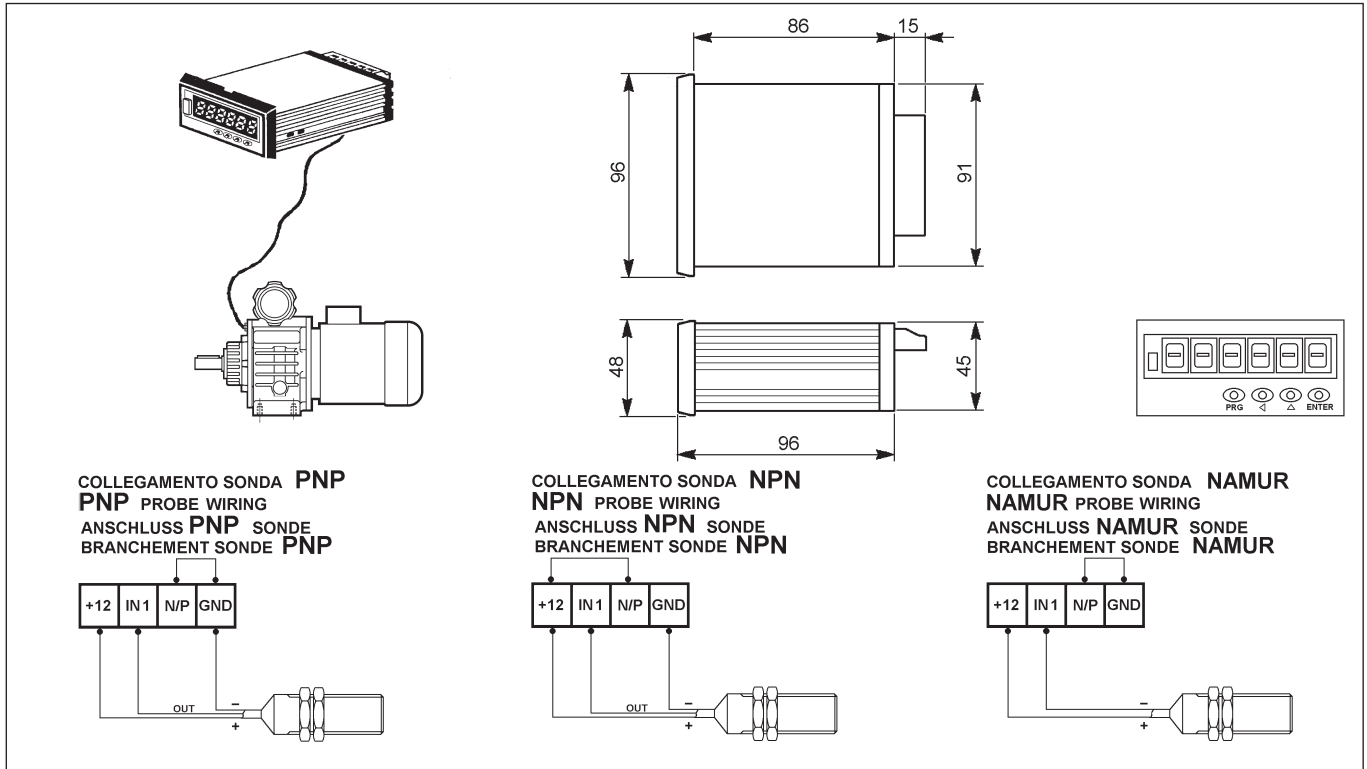

**Kit per rilevamento di giri  
KITCGY**

È un kit di montaggio per il rilevamento di giri applicabile su alberi esterni al variatore o su catene cinematiche generiche.

Il kit è composto da:

- A - un indicatore di giri digitale CGY (per le caratteristiche ed il funzionamento dell'indicatore vedi pag. 88)
- B - una sonda rilevatrice a forcella tipo NAMUR con cavo di connessione,
- C - una ruota fonica a 30 impulsi/giro.

Nella tabella (C13) sono riportati un esempio di applicazione, le dimensioni della sonda e della ruota fonica e lo schema di collegamento.

**KITCGY rpm detection kit**

*Speed detector kit. Can get the signal from a separate shaft or from a connected drive.*

*The kit consists of:*

- A - a digital rpm indicator of the CGY type (refer to page 88 for technical features and operation of the indicator).
- B - a fork probe of the NAMUR type with its proper connecting cable
- C - a phonic wheel with 30 impulses/rotation.

*The table (C13) shows an application example, probe and phonic wheel size and wiring diagram.*

**Anbausatz zur  
Drehzahlmittlung KITCGY**

Hierbei handelt es sich um einen Anbausatz zur Drehzahlmittlung, der z.B. außen an der Welle des Verstellgetriebes oder der Maschine angebracht werden kann.

Der Anbausatz besteht aus:

- A - einer digitalen Drehzahlanzeige CGY (für Eigenschaften und Betrieb des Anzeigers siehe Seite 88),
- B - eine Gabelermittlungssonde vom Typ NAMUR mit Anschlußkabel,
- C - ein Impulsgeber mit 30 Impulsen/Drehung.

In der Tabelle (C13) sind ein Anwendungsbeispiel, die Abmessungen der Sonde und des Impulsgebers, sowie der Anschlußplan aufgeführt.

**Kit pour détection de tours  
KITCGY**

*Il s'agit d'un kit de montage pour la détection de tours, applicable sur les arbres à l'extérieur du variateur ou sur des chaînes cinématiques en général.*

*Le kit se compose des éléments suivants :*

- A - un indicateur de tours digital CGY (en ce qui concerne les caractéristiques et le fonctionnement de l'indicateur, voir page 88).
- B - une sonde de détection à fourche type NAMUR avec câble de branchement.
- C - une roue phonique à 30 impulsions/tours.

*Le tableau (C13) présente un exemple d'application, les dimensions de la sonde et de la roue phonique ainsi que le schéma de branchement.*

(C13)

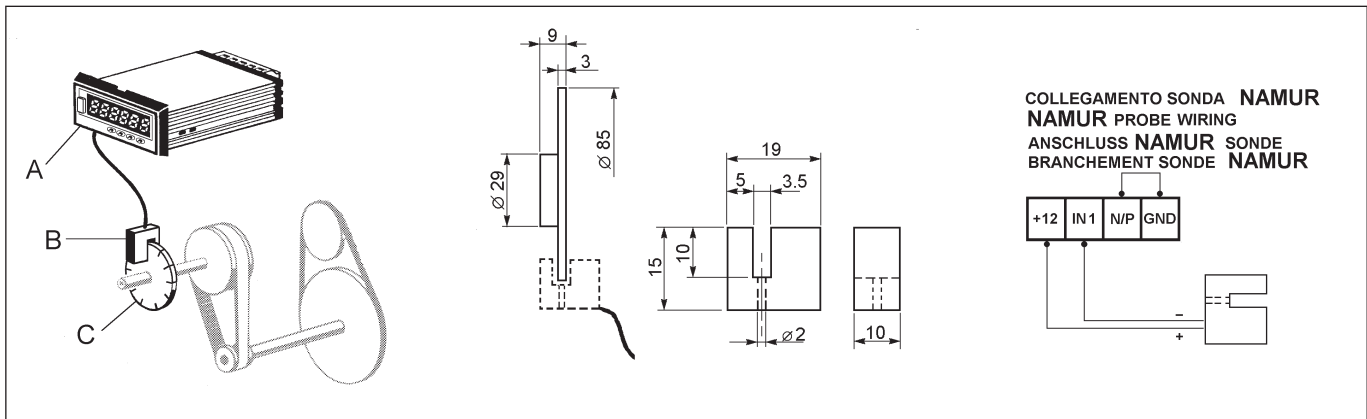

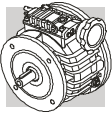

**Ingresso con albero veloce sporgente ENTHS**

Questo accessorio, costituito da un albero supportato da cuscinetti in costruzione chiusa, è applicabile all'ingresso dei variatori V 0.25...V 10 in tutte le forme costruttive nella configurazione P... (IEC) e permette di disporre di un albero sporgente utilizzabile per l'azionamento del variatore.

**Input with ENTHS input solid shaft**

The add-on ENTHS kit consists of a solid shaft supported by bearings and a connecting flange. It interfaces the variator's motor adapter, in the P(IEC) style. The solid input shaft can then be used to drive the variator.

**Antrieb mit freier Eingangswelle ENTHS**

Dieses Zubehörteil, das aus einer gelagerten Welle besteht, kann an den Antrieb der Verstellgetriebe V 0.25...V 10 in allen Bauformen in der Konfiguration P ... (IEC) angebracht werden. Dadurch erhält man eine freie Antriebswelle, die für die Installation von Anbauteilen an das Verstellgetriebe verwendet werden kann.

**Entrée avec arbre rapide sortant ENTHS**

Cet accessoire, constitué d'un arbre supporté par des roulements en construction fermée, est applicable à l'entrée des variateurs V 0.25...V 10, quelle que soit la forme de construction dans la configuration P.. (IEC), il permet de disposer d'un arbre sortant utilisable pour l'actionnement du variateur.

**AVVERTENZA**

Il kit **ENTHS** non è lubrificato autonomamente. Prima di assemblare il kit adattatore sulla flangia P(IEC) del variatore rimuovere l'anello di tenuta presente su quest'ultima, al fine di consentire la lubrificazione degli organi interni del kit.

**WARNING**

The kit **ENTHS** is not lubed independently. Prior to installing the adapter kit onto the P(IEC) input flange remove the oil seal that is present on the latter, so that inner parts of the adapter kit get lubricated.

**ACHTUNG**

Das Kit **ENTHS** wird nicht unabhängig geschmiert. Vor der Montage des Adapterkits an den P(IEC)-Eingangsflansch den vorderen Dichtring entfernen, damit die innenliegenden Teile des Adapterkits geschmiert werden.

**ATTENTION**

Le **ENTHS** n'est pas lubrifié autonomement. Avant d'assembler le kit adaptateur sur la bride P(IEC) du variateur, ôter la bague d'étanchéité présent sur cette dernière, au fin de permettre la lubrification des organes internes du kit.

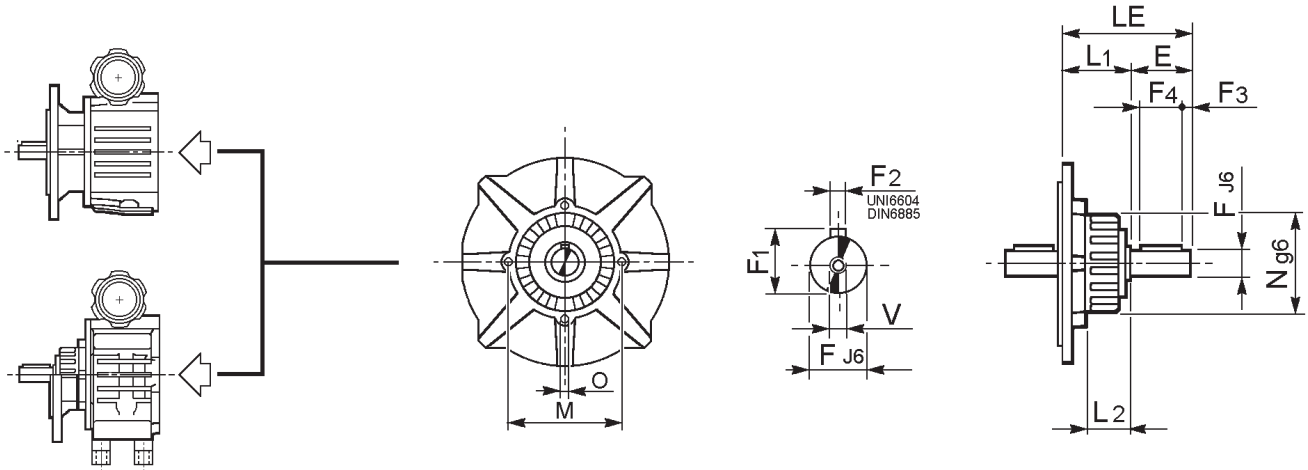

	E	F	F1	F2	F3	F4	LE	L1	L2	M	N	O	V
<b>ENTHS V 0.25</b>	23	11	12.5	4	2	20	58.5	35.5	26	68	55	M6	M4
<b>ENTHS V 0.5</b>	30	14	16	5	2.5	25	67	37	20	85	65	M6	M5
<b>ENTHS V 1</b>	40	19	21.5	6	5	30	88.5	48.5	25.5	95	80	M8	M6
<b>ENTHS V 2</b>	50	24	27	8	5	40	103.5	53.5	32	118	100	M8	M8
<b>ENTHS V 3</b>	60	28	31	8	5	50	121.5	61.5	37	150	110	M10	M10
<b>ENTHS V 5.5</b>	60	28	31	8	5	50	121.5	61.5	37	150	110	M10	M10
<b>ENTHS V 10</b>	80	38	41	10	5	70	160.5	80.5	64.5	200	135	M12	M12

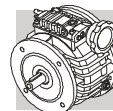

**Ingresso con modulo predisposto NEMA ENTN\_**

**Input with NEMA ENTN\_ adaptor**

**Anbausatz für NEMA-Motore Baueinheit ENTN\_**

**Entrée avec module prédisposé NEMA ENTN\_**

Questo accessorio è applicabile all'ingresso dei variatori V 0.25...V 10 in tutte le forme costruttive nella configurazione P...(IEC) e consente di disporre di una predisposizione Nema "C" Flange per il collegamento a motori elettrici rispondenti a tale normativa.

*The add-on ENTN\_ kit interfaces the variator's input flange, in the P(IEC) style, and allows a motor adapter to NEMA standard, to be used.*

Dieses Zubehörteil kann an den Antrieb der Verstellgetriebe V 0.25...V 10 in allen Bauformen in der Konfiguration P ... (IEC) angebracht werden. Hierdurch erhält man eine Anbaumöglichkeit für die nach der NEMA "C" Richtlinie genormten Elektromotoren.

*Cet accessoire est applicable à l'entrée des variateurs V 0.25...V 10 quelle que soit la forme de construction dans la configuration P... (IEC), il permet de disposer d'une prédisposition Nema "C"-Brides pour l'accouplement aux moteurs électriques conformes à cette norme.*

**AVVERTENZA**

Il kit **ENTN\_** non è lubrificato autonomamente. Prima di assemblare il kit adattatore sulla flangia P(IEC) del variatore rimuovere l'anello di tenuta presente su quest'ultima, al fine di consentire la lubrificazione degli organi interni del kit.

**WARNING**

*The kit ENTN\_ is not lubed independently. Prior to installing the adapter kit onto the P(IEC) input flange remove the oil seal that is present on the latter, so that inner parts of the adapter kit get lubricated.*

**ACHTUNG**

Das Kit **ENTN\_** wird nicht unabhängig geschmiert. Vor der Montage des Adapterkits an den P(IEC)-Eingangsfansch den vorderen Dichtring entfernen, damit die innenliegenden Teile des Adapterkits geschmiert werden.

**ATTENTION**

*Le ENTN\_ n'est pas lubrifié autonomement. Avant d'assembler l'kit adaptateur sur la bride P(IEC) du variateur, ôter la bague d'étanchéité présent sur cette dernière, au fin de permettre la lubrification des organes internes du kit.*

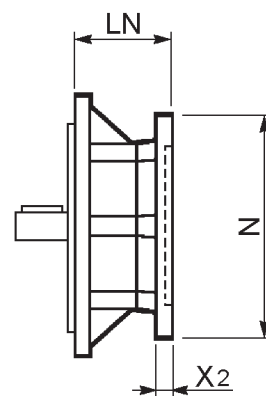
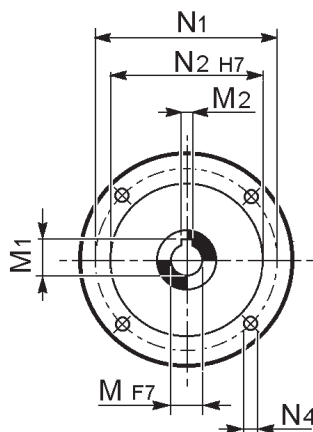
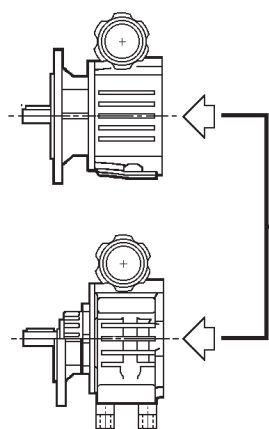

	LN	N	N1	N2	N4	M	M1	M2	X2
<b>ENTN56 V 0.25</b>	59	165	149.225	114.3	10.5	15.875	17.958	4.826	12
<b>ENTN56 V 0.5</b>	58	165	149.225	114.3	10.5	15.875	17.958	4.826	13
<b>ENTN56 V 1</b>	60	165	149.225	114.3	10.5	15.875	17.958	4.826	12
<b>ENTN143T V 1</b>	60	165	149.225	114.3	10.5	22.225	24.409	4.826	13
<b>ENTN145T V 2</b>	60	165	149.225	114.3	10.5	22.225	24.409	4.826	13
<b>ENTN182T V 3</b>	78.5	226	184.15	215.9	13.5	28.575	32.4	6.4	16
<b>ENTN184T V 5.5</b>	78.5	226	184.15	215.9	13.5	28.575	32.4	6.4	16
<b>ENTN213T V 10</b>	97	226	184.15	215.9	13.5	34.925	38.4	7.976	21

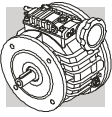

Questo accessorio è ulteriormente disponibile in esecuzione con cuscinetti autolubrificati per l'installazione in applicazioni generiche dove vi sia l'esigenza di trasformare una predisposizione IEC in una predisposizione NEMA "C" Flange.

*This accessory is also available with self-lubricating bearings for standard applications in which a IEC adaptor must be converted into a NEMA "C" Flange adaptor.*

Dieses Zubehör steht darüber hinaus auch in einer Ausführung mit geschlossenen Lagern zur Verfügung, falls man einen IEC-Anbausatz in einen NEMA "C"-Anbausatz umwandeln möchte.

*Cet accessoire est aussi disponible avec roulements autolubrifiants pour l'installation sur des applications nécessitant la transformation d'une prédisposition IEC en une prédisposition NEMA "C"-Brides.*

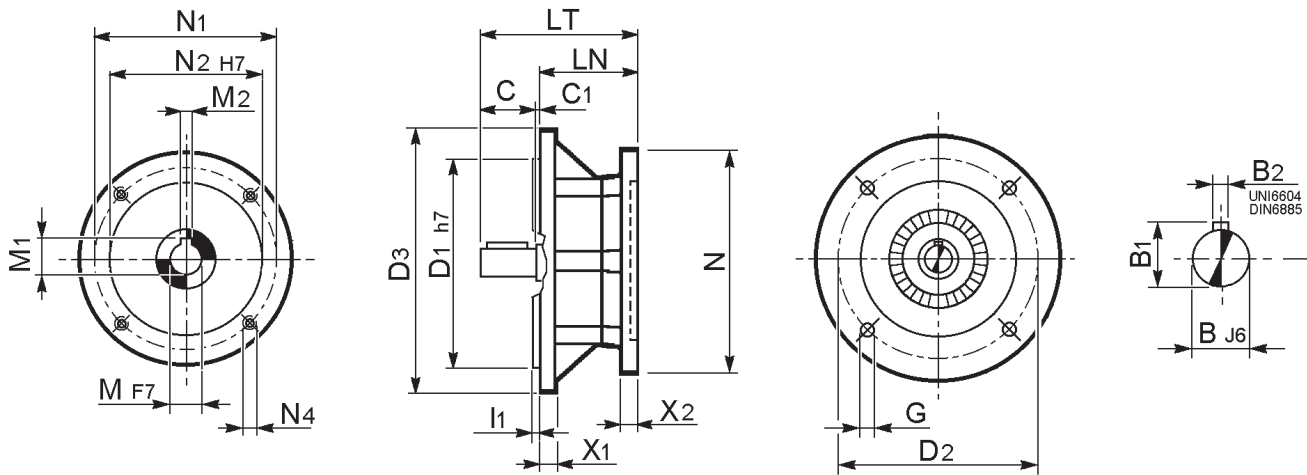

	IEC	B	B1	B2	C	C1	D1	D2	D3	G	I1	LN	LT	N	N1	N2	N4	M	M1	M2	X1	X2
<b>ENTN56 P63</b>	63	11	12.5	4	23	—	95	115	140	8.5	3	58.5	81.5	165	149.225	114.3	10.5	15.875	17.958	4.826	7.5	12
<b>ENTN56 P71</b>	71	14	16	5	30	—	110	130	160	9	3.5	57.5	87.5	165	149.225	114.3	10.5	15.875	17.958	4.826	7	13
<b>ENTN56 P80</b>	80	19	21.5	6	40	—	130	165	200	11	3.5	59.5	99.5	165	149.225	114.3	10.5	15.875	17.958	4.826	7	12
<b>ENTN143T P80</b>	80	19	21.5	6	40	—	130	165	200	11	3.5	59.5	99.5	165	149.225	114.3	10.5	22.225	24.409	4.826	7	13
<b>ENTN145T P90</b>	90	24	27	8	50	—	130	165	200	11	3.5	59.5	109.5	165	149.225	114.3	10.5	22.225	24.409	4.826	7	13
<b>ENTN182T P100</b>	100	28	31	8	60	2.5	180	215	250	14	4	78	140.5	226	184.15	215.9	13.5	28.575	32.4	6.4	7	16
<b>ENTN184T P112</b>	112	28	31	8	60	2.5	180	215	250	14	4	78	140.5	226	184.15	215.9	13.5	28.575	32.4	6.4	7	16
<b>ENTN213T P132</b>	132	38	41	10	80	-1	230	265	300	13	4	96.5	175.5	226	184.15	215.9	13.5	34.925	38.4	7.976	14	21

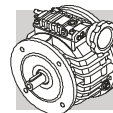





Flange di fissaggio

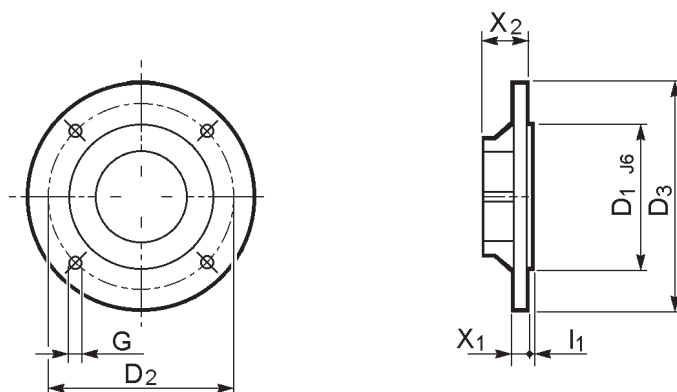

Mounting flange kit



Abtriebsflansch-Kit



Kit bride de fixation



			D1	D2	D3	G	I1	X1	X2
V 0.25_UP	—	FLANGIA F63	95	115	140	8.5	3	8	13.5
		FLANGIA F71	110	130	160	8.5	3.5	8	13.5
V 0.5_UP	VD 0.5_UP	FLANGIA F71	110	130	160	8.5	3.5	8	13.5
		FLANGIA F80/90	130	165	200	11.5	3.5	10	13.5
V 1_UP	VD 1_UP	FLANGIA F80/90	130	165	200	11.5	3.5	10	16
V 2_UP	VD 2_UP	FLANGIA F80/90	130	165	200	11.5	3.5	12	20.5
		FLANGIA F100/112	180	215	250	14	4	14	20.5

			D1	D2	D3	G	I1	X1	X2
V 3_U	VD 3_U	FLANGIA F100/112	180	215	250	14	4	14	40
		FLANGIA F132	230	265	300	14	4	14	40
V 5.5_U	VD 5.5_U	FLANGIA F100/112	180	215	250	14	4	14	40
		FLANGIA F132	230	265	300	14	4	14	40
V 10_U	VD 10_U	FLANGIA F132	230	265	300	14	4	16	66
		FLANGIA F160/180	250	300	350	18	5	15	66

			D1	D2	D3	G	I1	X1	X2
VR 0.25_U_	—	FLANGIA F71	110	130	160	9	3	8	16
VR 0.5_U_	VDR 0.5_U_	FLANGIA F71	110	130	160	9	3	8	16
VR 1_U_	VDR 1_U_	FLANGIA F80/90	130	165	200	11.5	3.5	10	12
VR 2_U_	VDR 2_U_	FLANGIA F100/112	180	215	250	13	4	12	20

			D1	D2	D3	G	I1	X1	X2
VR 3_U_	VDR 3_U_	FLANGIA F132	230	265	300	14	4	16	14
VR 5.5_U_	VDR 5.5_U_	FLANGIA F132	230	265	300	14	4	16	14
VR 10_U_	VDR 10_U_	FLANGIA F160/180	250	300	350	18	5	15	16

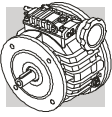

### Piedi di fissaggio

Questo accessorio è costituito da due basi applicabili ai variatori V 0.25...V 10 nella forma costruttiva U e permette di disporre di fori di ancoraggio passanti e collocati all'esterno dell'ingombro del variatore stesso.

### Fastening feet

The add-on foot kit bolts underneath V variators, in the U version, and carries through holes for the connection of the variator to the base plate.

### Fußplatte

Dieses Zubehörteil besteht aus zwei Platten, die an den Verstellgetrieben V 0.25...V 10 in der Bauform U angebracht werden können. Es ermöglicht die Montage des Getriebes durch Bohrungen, die seitlich vom Gehäuse des Getriebes liegen.

### Pieds de fixation

Cet accessoire est constitué de deux bases applicables aux variateurs V 0.25...V 10 dans la forme de construction U et permet de disposer d'orifice de fixation passants et situés à l'extérieur de l'encombrement du variateur.

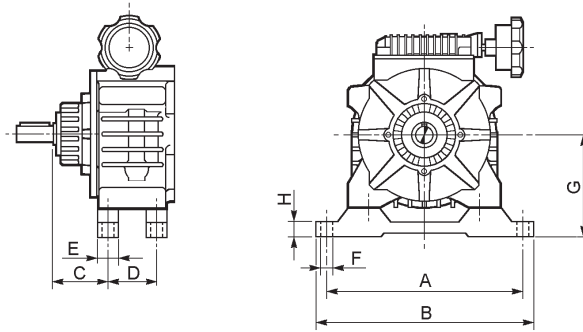

	A	B	C	D	E	F	G	H
<b>PIEDI V 0.25</b>	164	183	48	51.5	20	9	83	10
<b>PIEDI V 0.5</b>	172	191	47.5	57	20	9	89	9
<b>PIEDI V 1</b>	220	242	59.5	71	26	11	115	12
<b>PIEDI V 2</b>	245	267	62.5	96	30	11	140	23
<b>PIEDI V 3</b>	297	323	76.5	120	35	13	169	27
<b>PIEDI V 5.5</b>	297	323	76.5	120	35	13	169	27
<b>PIEDI V 10</b>	314	336	101.5	160	55	13	210	28

### Indicatore gravitazionale INDGRAV

È un indicatore di posizione a reazione gravitazionale applicabile sul volantino di comando dei variatori e indica, su una doppia scala graduata, i giri e frazioni di giro compiuti dal volantino stesso durante il movimento di rotazione e deve operare con l'asse orizzontale o avente piccoli angoli di inclinazione (Max. 15°).

### INDGRAV gravitational indicator

The device is a gravitational turns indicator which can be fitted onto the variator control handwheel for indicating rpms and turn fractions on a double graduated scale during the rotation. This indicator works only with horizontal axis or small angles of inclination (Max. 15°).

### Lageanzeige INDGRAV

Hierbei handelt es sich um eine nach dem Schwerkraftsgesetz arbeitende Lageanzeige, die auf dem Handrad der Verstellgetriebe angebracht werden kann. Sie gibt auf einer doppelten Gradskala die vom Handrad ausgeführten Umdrehungen an. Die Achse der Anzeige muß möglichst waagrecht sein, da die Anzeige sonst nicht einwandfrei arbeiten kann (Max. 15°).

### Indicateur gravitationnel INDGRAV

Il s'agit d'un indicateur de position à réaction gravitationnelle applicable sur le volant de commande des variateurs, il indique, sur une double échelle graduée, les tours et fractions de tours accomplis par le volant durant le mouvement de rotation, il doit opérer avec l'axe horizontal ou ayant de faibles angles d'inclinaison (Max. 15°).

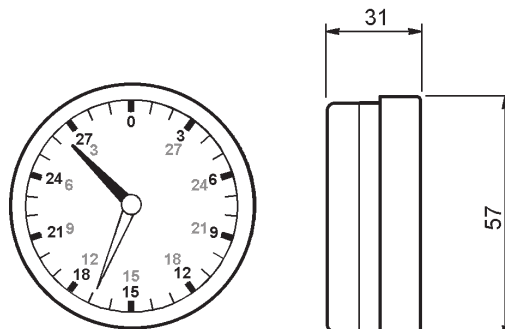



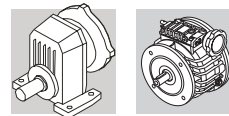

**21.0 - MOTOVARIARIDUTTORI**  
***MOTORIZED GEARED VARIATOR***  
***VERSTELLGETRIEBEMOTOREN***  
***MOTOVARIAREDUCTEURS***

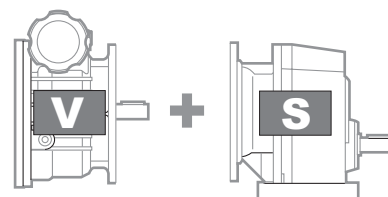

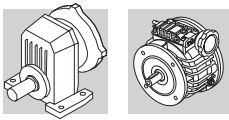

21.1 - Designazione riduttore

21.1 - Gearbox designation

21.1 - Getriebebezeichnung

21.1 - Désignation réducteur

**S 10 1 P 1.4 V05 B3 .....**

OPZIONI / OPTIONS  
OPTIONEN / OPTIONS

POS. DI MONTAGGIO / MOUNTING POSITIONS  
EINBAULAGEN / POS. DE MONTAGE

S...P : **B3** (Standard), **B6, B7, B8, V5, V6**  
S...F : **B5** (Standard), **B51, B52, B53, V1, V3**

DESIGNAZIONE INGRESSO / INPUT DESIGNATION  
BEZEICHNUNG DER ANTRIEBSSEITE / DESIGNATION ENTREE

**V** + grandezza variatore = Predisposto per variatore compatto  
**V** + variator size = suitable to match compact variator  
**V** + Verstellgetriebegröße = für kompaktes Verstellgetriebe geeignet  
**V** + grandeur variateur = prédisposé pour variateur compact

V025	V05	V1	V2	V3	V55	V10
V 0.25	V 0.5	V 1	V 2	V 3	V 5.5	V 10

**P** + grandezza motore = Predisposto per variatore flangiato  
**P** + motor size = suitable to match a flanged variator  
**P** + Motorgröße = für geflanshtes Verstellgetriebe geeignet  
**P** + taille moteur = prédisposé pour variateur avec bride

P63	P71	P80	P90	P100	P112	P132
V 0.25	V 0.5	V 0.5 V 1	V 1 V 2	V 3	V 5.5	V 10

RAPPORTO DI RIDUZIONE / GEAR RATIO  
ÜBERSETZUNG / RAPPORT DE REDUCTION

FORMA COSTRUTTIVA / VERSION / BAUFORM / FORME DE CONSTRUCTION

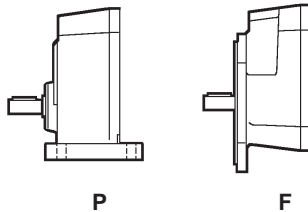

N° STADI DI RIDUZIONE / REDUCTIONS  
ANZAHL DER GETRIEBESTUFEN / N.bre ETAGES DE REDUCTION

1

GRANDEZZA RIDUTTORE / GEARBOX SIZE  
GETRIEBEBAUGRÖSSE / TAILLE REDUCTEUR

10, 20, 30, 40, 50

TIPO RIDUTTORE: **S** = monostadio  
GETRIEBETYP: **S** = Stirradgetriebemotore-Einstufig

GEARBOX TYPE: **S** = single stage  
TYP DU REDUCTEUR: **S** = à un étage de réduction

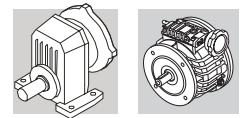

21.2 - Designazione variatore

21.2 - Designation of variator

21.2 - Bezeichnung für Drehzahlwandler

21.2 - Désignation variateur

**V**  **0.5** **C**   **P71** **B3** **1** **PDN** **SCT** ....

OPZIONI / OPTIONS  
OPTIONEN / OPTIONS

TIPO DI COMANDO / REMOTE CONTROL TYPE  
VERSTELLEINRICHTUNG / TYPE DE COMMANDE  
**A, VG, VA, VAG, SCT (3Ø), TC (1Ø)**

SONDA RILEVATRICE / SPEED SENSOR  
MEßSONDE / SONDE DE DETECTION  
**PDN, PDNA, PDP**

POSIZIONE DISPOSITIVO DI COMANDO / SPEED KNOB POSITION  
EINBAULAGE DER VERSTELLEINRICHTUNG / POSITION COMMANDE  
**1 (default), 2 (V 3...V 10)**

POSIZIONE DI MONTAGGIO / MOUNTING POSITION  
MOTOR BAUFORM / FORME DE CONSTRUCTION DU MOTEUR  
**B3 (default), B6, B7, B8, V5, V51, V52, V53, V6, V61, V62, V63**

104

CONFIGURAZIONE INGRESSO / INPUT CONFIGURATION  
BEZEICHNUNG DER ANTRIEBSSEITE / DESIGNATION ENTREE

- P (IEC)** - predisposizione IEC / Provided with IEC motor adaptor  
vorbereitet für den Anbau eines IEC-Motors / prédisposé IEC
- HS** - albero cilindrico / solid input shaft / freier Antriebswelle / arbre rapide sortant
- HSF** - albero cilindrico e flangia riportata / solid input shaft and bolt-on flange  
freier Antriebswelle und Flansch / arbre rapide sortant et adjonction de bride
- N (NEMA)** - predisposizione motore NEMA / provided with Nema motor adaptor  
vorbereitet für den Anschluß eines NEMA-Motors / prédisposé moteur NEMA
- G (IEC)** - flangia IEC maggiorata / provided with IEC extended adaptor  
mit zusätzlicher Baueinheit für IEC-Motore / avec module supplémentaire prédisposé IEC

DIAMETRO ALBERO LENTO / OUTPUT SHAFT BORE  
ABTRIEBSWELLE DURCHMESSER / DIAMETRE ARBRE LENT

**D +** diametro in mm / diameter in mm  
Durchmesser in mm / diamètre en mm **(11,14,...)**

<b>D11</b>	<b>D14</b>	<b>D19</b>	<b>D24</b>	<b>D28</b>	<b>D28</b>	<b>D38</b>
(V 0.25)	(V 0.5)	(V 1)	(V 2)	(V 3)	(V 5.5)	(V 10)

**IMP** albero in pollici / inch series shaft / Nema-Welle / arbre NEMA

TIPO DI FISSAGGIO (per gruppi tipo U) / OUTPUT CONFIGURATION (only for U version)  
MONTAGEMÖGLICHKEIT (ausschließlich für die Bauform U) / TIPE DE FIXATION (pour forme de construction U)

- F (IEC)** - flangia IEC riportata / bolt-on IEC flange / Flansch IEC / adjonction de bride IEC
- F (NEMA)** - flangia NEMA / NEMA flange mounted / NEMA Flansch / bride Nema

FORMA COSTRUTTIVA / VERSION / BAUFORM / VERSION



**C**

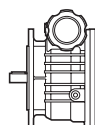

**F**

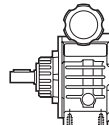

**U**

GRANDEZZA VARIATORE / VARIATOR SIZE / BAUGRÖSSE / TAILLE VARIATEUR  
**0.25, 0.5, 1, 2, 3, 5.5, 10**

DIFFERENZIALE / DIFFERENTIAL / DIFFERENTIAL / DIFFERENTIEL  
**D**

VARIATORE / VARIATOR TYPE / VERSTELLGETRIEBETYP / TYPE VARIATEUR  
**V**

21.3 - Designazione motore

21.3 - Motor designation

21.3 - Motor bezeichnung

21.3 - Désignation moteur

25

25

25

25

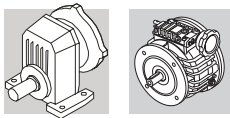

## 21.4 - Opzioni riduttori

### SO

I riduttori S10, S20, S30, S40, solitamente forniti con lubrificante da BONFIGLIOLI RIDUTTORI, sono forniti privi di lubrificante.

### LO

Il riduttore S50 solitamente sprovvisto di lubrificante, è richiesto con olio sintetico del tipo correntemente utilizzato da BONFIGLIOLI RIDUTTORI e riempito in accordo alla posizione di montaggio richiesta.

### VV

Anello di tenuta in fluoro-elastomero sull'albero veloce.

### PV

Tutti gli anelli di tenuta in fluoro-elastomero.

## 21.5 - Opzioni variatori

### CU

Cassa universale con piano di appoggio spianato e relativi fori di fissaggio (pag. 28).

### FL

Cassa universale con fianchi laterali spianati e relativi fori di fissaggio (pag. 28).

### PDN

Predisposizione al rilevamento di giri digitale incorporato all'interno del variatore con sonda rilevatrice di tipo NPN.

### PDP

Predisposizione al rilevamento di giri digitale incorporato all'interno del variatore con sonda rilevatrice di tipo PNP.

La tabella (D01) riporta le possibilità di applicazione e le dimensioni delle sonde NPN e PNP utilizzate.

(D01)

Riduttore Gearbox Getriebe Réducteur	Sonda Plug thread Sonde (NPN/PNP)	Variatore Variator Verstellgetriebe Variateur	Forme costruttive / Versions Bauformen / Formes de construction		
			V		V_D
			C	F-UF	UF
<b>S 101</b>	M8x1	V 0.25	#		
	M8x1	V 0.5	#		
<b>S 201</b>	M8x1	V 0.25	#		
	M8x1	V 0.5	#		
	M10x1	V 1	#		
<b>S 301</b>	M8x1	V 0.25	#		
	M8x1	V 0.5	#		
	M10x1	V 1	#		
		V 2	#		

Applicazioni disponibili

Option availability

# Applicazione disponibile per le posizioni di montaggio B3, a richiesta (come esecuzione speciale) per le altre posizioni di montaggio.

# The option is available for units in the B3 mounting position. For other positions, please enquire with Bonfiglioli.

### PV

Anelli di tenuta in fluoro-elastomero.

### SO

I variatori V 0.25...V 10 solitamente forniti con lubrificante da Bonfiglioli Riduttori sono forniti privi di lubrificante. Questa opzione non è prevista per i variatori con differenziale VD 0.5...VD 10 con ingresso P.. in quanto normalmente forniti privi di lubrificante.

### PV

Fluoro elastomer seals.

### SO

The V 0.25...V 10 variators – normally factory-filled with oil – are supplied dry. This option is not available on the VD 0.5...VD 10 variators with differential unit and P.. input, that are normally supplied dry.

## 21.4 - Getriebe Optionen

### SO

Bei Lieferung ohne Schmierstoff (nur bei S10, S20, S30 und S40).

### LO

Für Getriebe S50, die gewöhnlich ohne Schmiermittel geliefert werden, in Übereinstimmung mit der Einbaulage gefüllt mit dem normalerweise von BONFIGLIOLI RIDUTTORI verwendeten synthetischen Schmierstoff.

### VV

Wellendichtringe aus Fluor-Elastomer auf der eintreibenden Welle.

### PV

Alle Wellendichtringe aus Fluor-Elastomer.

## 21.5 - Optionen – Verstelltriebemotor

### CU

Universalgehäuse mit plangeschliffener Auflagefläche und entsprechenden Befestigungsbohrungen (Seite 28).

### FL

Universalgehäuse mit plangeschliffenen Seitenflanken und entsprechenden Befestigungsbohrungen (Seite 28).

### PDN

Vorbereitet für im Verstellgetriebe eingebaute digitale Vorrichtung für die Drehzahlerhebung über eine PNP-Sonde.

### PDP

Vorbereitet für im Verstellgetriebe eingebaute digitale Vorrichtung für die Drehzahlerhebung über eine PNP-Sonde.

In der Tabelle (D01) werden die möglichen Applikationsmöglichkeiten der verwendeten NPN- und PNP-Sonden aufgeführt.

## 21.4 - Options réducteurs

### SO

Les réducteurs S10, S20, S30, S40, habituellement fournis avec lubrifiant par la société BONFIGLIOLI RIDUTTORI, sont demandés sans lubrifiant.

### LO

Le réducteur S50, habituellement dépourvu de lubrifiants, sont demandés avec huile synthétique du type couramment utilisé par BONFIGLIOLI RIDUTTORI et remplis conformément à la position de montage demandée.

### VV

Bague d'étanchéité en Elastomère fluoré sur l'arbre rapide.

### PV

Toutes les bagues d'étanchéité en Elastomère fluoré.

## 21.5 - Options variateurs

### CU

Caisse universelle avec plan d'appui aplati et orifices de fixation correspondants (page 28).

### FL

Caisse universelle avec flancs latéraux aplatis et orifices de fixation correspondants (page 28).

### PDN

Prédisposition pour le dispositif de mesure du nombre de tours digital incorporé à l'intérieur du variateur avec sonde de détection de type NPN.

### PDP

Prédisposition pour le dispositif de mesure du nombre de tours digital incorporé à l'intérieur du variateur avec sonde de détection de type PNP.

Le tableau (D01) indique les différentes possibilités d'application ainsi que les dimensions des sondes NPN et PNP utilisées.

Riduttore Gearbox Getriebe Réducteur	Sonda Plug thread Sonde (NPN/PNP)	Variatore Variator Verstellgetriebe Variateur	Forme costruttive / Versions Bauformen / Formes de construction		
			V		V_D
			C	F-UF	UF
<b>S 401</b>	M8x1	V 0.5	#		
	M10x1	V 1	#		
		V 2	#		
<b>S 501</b>	M12x1	V 3/5.5	—		
		V 1	#		
	M10x1	V 2	#		
		V 3/5.5			
		V 10	—		

Zur Verfügung stehende Anwendungen

Applications disponibles

# Anwendung auch für die Montagepositionen B3 erhältlich; auf Anfrage (als Sonderausführung) auch für die anderen Montagepositionen.

# Application disponible pour les positions de montage B3, sur demande (exécution spéciale) pour les autres positions de montage.

### PV

Dichtringe in Fluor-Elastomer.

### SO

Die üblicherweise von der Bonfiglioli Riduttori mit Schmiermittel gelieferten Verstellgetriebe V 0.25...VBG 10 werden bei dieser Ausführungsart ohne Schmiermittel geliefert. Diese Option ist bei den Verstellgetrieben mit Antrieb P.. VD 0.5...VD 10 mit Differential nicht gegeben, da diese normalerweise ohne Schmiermittel geliefert werden.

### PV

Bagues d'étanchéité en Elastomère fluoré.

### SO

Les variateurs V 0.25...V 10 généralement fournis avec du lubrifiant par Bonfiglioli Riduttori sont fournis sans lubrifiant. Cette option n'est pas prévue pour les variateurs avec différentiel VD 0.5...VD 10 avec entrée P.. dans la mesure où il sont normalement fournis sans lubrifiant.

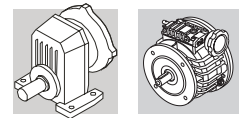

## 21.6 - Lubrificazione

### Lubrificazione riduttori serie S

Gli organi interni dei riduttori Bonfiglioli sono lubrificati con un sistema misto di immersione e sbattimento dell'olio.

I gruppi S10, S20, S30 e S40 sono normalmente consegnati con carica di lubrificante dalla fabbrica, o dalla rete di vendita ufficiale. I gruppi di grandezza S50 sono normalmente forniti privi di lubrificante, e sarà cura dell'utilizzatore riempirli di olio prima della messa in servizio.

In entrambi i casi, a seconda delle versioni, prima della messa in esercizio del riduttore potrebbe essere necessario sostituire il tappo chiuso usato per il trasporto con il tappo di sfianto fornito a corredo.

Le tavole che seguono sono da riferimento nell'interpretazione delle posizioni di montaggio, della collocazione dei tappi di servizio e delle quantità di lubrificante. **Queste ultime sono indicative; per il corretto riempimento si dovrà fare riferimento tassativamente alla mezziera del tappo di livello trasparente o all'astina (tacca di riferimento) o allo sfioramento del foro del tappo, quando presenti. Rispetto a questa condizione la quantità di lubrificante riportata in tabella può presentare scostamenti, occasionalmente anche rilevanti.**

Il lubrificante "long life" fornito di serie è di natura sintetica e, a meno di contaminazione dall'esterno, non richiede sostituzioni periodiche per tutto l'arco di vita del riduttore.

Il funzionamento dei riduttori è ammesso per temperature ambiente comprese fra -20°C e +40°C. Per temperature ambiente comprese fra -20°C e -10°C l'avviamento del riduttore potrà avvenire solo dopo aver effettuato un pre-riscaldamento progressivo ed omogeneo del gruppo, oppure con funzionamento "a vuoto", senza carico collegato. Il carico potrà poi essere applicato all'albero del riduttore quando la temperatura dello stesso avrà raggiunto la temperatura di -10°C, o superiore.

## 21.6 - Lubrication

### Lubrication of S gearboxes

*The inner parts of Bonfiglioli gear units are oil-bath and splash lubricated.*

*Frame sizes S10, S20, S30 and S40 are supplied by the factory, or by the authorized dealers, already filled with oil.*

*Unless otherwise specified, units size S50 are usually supplied unlubricated at it will be the customer care to fill them with oil prior to putting them into operation.*

*In both cases, depending on the version, prior to putting the gear unit into operation may need to replace the closed plug used for transportation purposes with breather plug supplied with.*

*The charts here after must be referred to as for the mounting position pattern and the corresponding oil plugs, if applicable, and related lubricant quantity.*

*These figures are only indicative; to ensure correct filling, always refer to the centreline of the sight glass, the notch on the dipstick, or the spill level of the filler plug hole, whichever is present.*

*In some cases, discrepancies, occasionally also substantial, versus the oil quantities listed in the chart may be noticed.*

*The "long life" polyglycol-based lubricant supplied by the factory, in the absence of contamination, does not require periodical oil changes throughout the life of the gear unit.*

*Operation of gear units is permitted at ambient temperatures between -20°C and +40°C. However, for temperatures between -20°C and -10°C unit may only start up after it has been progressively and evenly pre-heated, or otherwise initially operated unloaded.*

*Load may then be connected to the output shaft when the gear unit has reached the temperature of -10°C, or higher.*

## 21.6 - Schmierung

### Schmierung der Getriebe der Serie S

Die Schmierung der Getriebe von Bonfiglioli erfolgt durch eine Kombination aus Ölbad- und Tauchschmierung.

Die Getriebegrößen S10, S20, S30 und S40 sind ab Werk mit einer Lebensdauerschmierung versehen. Die Getriebe ab der Größe S50 werden ohne Ölfüllung ausgeliefert. Vor der Inbetriebnahme muss deshalb auf das Einfüllen der richtigen Ölfüllmenge geachtet werden!

In beiden Fällen, nach den Ausführungen, vor des Getriebe Inbetriebnahme, könnte notwendig sein, den geschlossenen Pfropfen mit dem Entlüftungspfropfen, der zusammen mit dem Getriebe geliefert ist, zu wechseln.

Bitte beachten Sie dazu auch die nachfolgenden Kapitel über die Positionen der Stopfen und Ölschaugläser und den entsprechenden Ölfüllmengen.

**Die Letztgenannten sind Richtwerte; zur korrekten Befüllung ist obligatorisch auf die Mittellinie des durchschnittlichen Öleinfüllstopfens, den Messstab (Markierung) oder den Überlaufschutz des Stopfens, sofern vorhanden, Bezug zu nehmen. Auf Abweichungen gegenüber den in der Tabelle angegebenen Ölmengen, gelegentlich nicht unwesentliche, wird hingewiesen.**

Die mit Lebensdauerschmierung gelieferten Serien sind mit synthetischem Öl auf Polyglykolbasis gefüllt. Falls dieses Öl nicht verunreinigt wird, ist während der Lebensdauer des Getriebes kein Ölwechsel nötig.

Die Getriebe dürfen bei einer Umgebungstemperatur von -20°C bis +40°C betrieben werden. Allerdings darf ein Start unter Last bei -20°C bis -10°C erst nach stufenweiser und gleichmäßiger Vorwärmung erfolgen. Anderfalls muss das Anfahren ohne Last erfolgen. Die Last darf erst zugeschaltet werden, wenn die Getriebeeinheit eine Temperatur von mindestens -10° oder höher erreicht hat.

## 21.6 - Lubrification

### Lubrification réducteurs Série S

*Les organes internes des réducteurs Bonfiglioli sont lubrifiés avec un système mixte d'immersion et de battement de l'huile.*

*Les groupes S10, S20, S30 et S40 sont normalement livrés avec charge de lubrifiant de l'usine, ou du réseau de vente officielle. Les groupes de grandeur S50 sont normalement fournis sans lubrifiant, et sera par l'utilisateur le remplissage d'huile avant la mise en service.*

*Dans les deux cas, selon les versions, avant la mise en service du réducteur, pourrait être nécessaire de remplacer le bouchon fermé utilisé pour le transport par le bouchon d'évent fourni.*

*Les tables suivantes sont de référence dans l'interprétation des positions de montage, du placement des bouchons de service et de la quantité de lubrifiant.*

**Ces dernières sont indicatives; pour un remplissage correct, il faut se référer obligatoirement au milieu du bouchon de niveau transparent ou à la jauge (encoche de repère) ou à l'effleurement du trou du bouchon, quand ils existent.**

**Par rapport à cette condition la quantité de lubrifiant indiquée dans le tableau peut présenter des écarts, occasionnellement considérables.**

*Le lubrifiant "long life"; fourni de série est de nature synthétique et, à moins de contamination par l'extérieur, il ne demande pas des remplacements périodiques pour tout l'arc de vie du réducteur.*

*Le fonctionnement des réducteurs est admis pour des températures ambiantes comprises entre -20°C et +40°C. Pour des températures ambiantes comprises entre -20°C et -10°C le démarrage du réducteur est admis seulement après un préchauffage progressif et homogène, ou avec un fonctionnement « à vide », sans charge appliquée. La charge pourra être ensuite appliquée à l'arbre du réducteur quand celui-ci aura atteint une température de -10°C, ou supérieure.*

	Viscosità olio ISO VG / Oil viscosity ISO VG / Öl-Viskosität ISO VG / Viscosité de l'huile ISO VG				
	T <sub>a</sub> ≤ -20°	-20° < T <sub>a</sub> ≤ 10°	0° ≤ T <sub>a</sub> ≤ 30°	20° ≤ T <sub>a</sub> ≤ 40°	T <sub>a</sub> > 40°
<b>Mineral EP</b>	(*)	150	320	460	460 (*)
<b>PAO EP</b>	(*)	150	220	320	460 (*)
<b>PAG</b>	(*)	150	220	320	460 (*)

**PAO** Oli sintetici polialfaolefine

**PAO** Polyalphaolefin synthetic oils

**PAO** Synthetische Poly-Alpha-Olefin-Öle

**PAO** Huiles synthétiques polyalphaoléfinés

**PAG** Oli sintetici a base poliglicolica

**PAG** Polyglycol-based synthetic oils

**PAG** Synthetische Öl auf Polyglycol basierend

**PAG** Huiles synthétiques à base de polyglycol

(\*) consultare il Servizio Tecnico Commerciale.

(\*) consult Bonfiglioli Technical Service.

(\*) Bitte wenden Sie sich an die technische Abteilung von

(\*) Consulter le service technique Bonfiglioli.

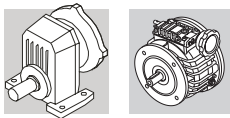

Quantità di lubrificante [ l ]

Oil quantity [ l ]

Schmiermittelmenge [ l ]

Quantité de lubrifiant [ l ]

(D02)

	P						F					
	B3	B6	B7	B8	V5	V6	B5	B51	B53	B52	V1	V3
<b>S 10 1</b>	0.45	0.45	0.45	0.45	0.45	0.45	0.45	0.45	0.45	0.45	0.45	0.45
<b>S 20 1</b>	0.65	0.65	0.65	0.65	0.65	0.65	0.65	0.65	0.65	0.65	0.65	0.65
<b>S 30 1</b>	0.85	0.85	0.85	0.85	0.85	0.85	0.85	0.85	0.85	0.85	0.85	0.85
<b>S 40 1</b>	2.1	2.1	2.1	2.1	2.1	2.3	2.1	2.1	2.1	2.1	2.1	2.3
<b>S 50 1</b>	1.6	3.1	2.3	3.6	3.1	2.7	1.7	3.5	3.0	1.9	3.4	2.6

Lubrificazione a vita

Life lubricated

Dauerschmierung

Lubrification permanente

● SHELL OMALA S4 WE 320 (for life)

**Dimensioni e collocazione dei tappi di carico, scarico e livello olio.**

**Positions of oil filling, level and drain plugs.**

**Anordnung des Einfüll, Ölstands- und Ölablaßschrauben.**

**Position des bouchons de remplissage, niveau et vidange d'huile.**

(D03)

**Legenda:**

**C** Tappo di carico/sfiato  
**L** Tappo di livello  
**S** Tappo di scarico  
**T** Tappo chiuso

**Zeichenerklärung:**

**C** Einfüll- und Ablassschrauber  
**L** Ölstandsschraube  
**S** Ölablaßschraube  
**T** geschlossene Schraube

**Key:**

**C** Filling/breather plug  
**L** Level plug  
**S** Drain plug  
**T** Closed plug

**Légende:**

**C** Bouchon de remplissage/évent  
**L** Bouchon de niveau  
**S** Bouchon de vidange  
**T** Bouchon fermé

Posizioni di montaggio / Mounting positions / Einbaulagen / Positions de montage												
	P						F					
	B3	B6	B7	B8	V5	V6	B5	B51	B52	B53	V1	V3
<b>S101</b>	3 T (1/4")	3 T (1/4")	3 T (1/4")	3 T (1/4")	3 T (1/4")	3 T (1/4")	3 T (1/4")	3 T (1/4")	3 T (1/4")	3 T (1/4")	3 T (1/4")	3 T (1/4")
<b>S201</b>	3 T (1/4")	3 T (1/4")	3 T (1/4")	3 T (1/4")	3 T (1/4")	3 T (1/4")	3 T (1/4")	3 T (1/4")	3 T (1/4")	3 T (1/4")	3 T (1/4")	3 T (1/4")
<b>S301</b>	3 T (1/4")	3 T (1/4")	3 T (1/4")	3 T (1/4")	3 T (1/4")	3 T (1/4")	3 T (1/4")	3 T (1/4")	3 T (1/4")	3 T (1/4")	3 T (1/4")	3 T (1/4")
<b>S401</b>	3 T (1/4")	3 T (1/4")	3 T (1/4")	3 T (1/4")	3 T (1/4")	3 T (1/4")	3 T (1/4")	3 T (1/4")	3 T (1/4")	3 T (1/4")	3 T (1/4")	3 T (1/4")
<b>S501</b>	1 C (3/8")	2 S (3/8")	2 C (3/8")	1 S (3/8")	1 C (3/8")	1 S (3/8")	1 C (3/8")	2 S (3/8")	1 C (3/8")	2 S (3/8")	1 C (3/8")	1 S (3/8")
	3 S (3/8")	3 L (3/8")	3 L (3/8")	5 L (3/8")	4 L (3/8")	4 L (3/8")	3 S (3/8")	3 L (3/8")	5 L (3/8")	3 L (3/8")	4 L (3/8")	4 L (3/8")
	2 L (3/8")	4 C (3/8")	4 S (3/8")	3 C (3/8")	5 S (3/8")	5 C (3/8")	2 L (3/8")	4 C (3/8")	3 S (3/8")	4 C (3/8")	5 S (3/8")	5 C (3/8")

• Numero di riferimento delle posizioni dei tappi di carico, scarico e livello olio.

• Reference number for positions of oil filling, level and drain plugs.

• Bezugsnummer der Positionen des Einfüll Ölstands- und Ölablaßschrauben.

• Numéro de référence des positions des bouchons de remplissage, vidange et niveau.

**21.7 - Lubrificazione variatori**

**21.7 - Lubrication of variators**

**21.7 - Schmierung der Verstellgetriebe**

**21.7 - Lubrification variateurs**

**V, VD**

La lubrificazione dei variatori V e VD avviene per sbattimento dell'olio. Prima della messa in funzione dei variatori accertarsi della presenza di olio al loro interno assicurandosi che esso compaia nella spia di livello.

**V and VD**

Variators V and VD are splash-lubricated. Before putting the variator into operation make sure the oil is up to the sight glass level.

**V, VD**

Die Schmierung der Verstellgetriebe V und VD erfolgt durch Tauchschmierung im Ölbad. Vor der Inbetriebnahme der Verstellgetriebe muß geprüft werden, ob sie bis zur Ölstandskontrolle mit Öl gefüllt sind.

**V, VD**

La lubrification des variateurs V et VD s'effectue par barbotage de l'huile. Avant la mise en service des variateurs/motovariateurs, vérifier la présence d'huile à l'intérieur en contrôlant que celle-ci apparaisse dans le témoin de niveau.

**VD**

Tutti i variatori con differenziale VD completi di motore vengono forniti con carico di olio. Tutti i variatori con differenziale VD in configurazione P... (IEC), vengono forniti privi di olio. In questo caso l'utente dovrà provvedere al riempimento im-

**VD**

Motorized VD variators featuring the differential unit are factory filled with oil unlike VD variators with the IEC motor adapter (P...) which are supplied unlubricated and must be filled with oil prior to be put into operation.

**VD**

Alle Verstellgetriebe mit Differential VD und Motor, sind bei Lieferung mit Öl gefüllt. Alle Verstellgetriebe mit Differential V-D für den Anbau eines IEC-Motors werden ohne Öl geliefert. Wenn der Kunde die Getriebe selbst mit Öl füllt, müssen die in

**VD**

Tous les variateurs avec différentiel VD avec moteur sont fournis avec le plein d'huile. Tous les variateurs avec différentiel VD en configuration P... (IEC) sont fournis sans huile. Dans ce cas, l'utilisateur doit effectuer le remplissage en versant

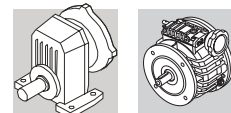

mettendo le quantità di olio indicate nelle tabelle (D04-D05) e dovrà utilizzare motori elettrici con l'anello di tenuta lato albero e la flangia di accoppiamento al variatore a tenuta di olio.

*Proper oil quantity is shown in table (D04-D05) and relates to actual mounting position.*

Tabelle (D04-D05) angegebenen Ölmengen verwenden werden. Die zu verwendenden Motoren müssen einen Dichtring auf der Seite der Welle haben und der Flansch zur Kopplung an das Verstellgetriebe muß öldicht sein.

*la quantité d'huile indiquée dans le tableau (D04-D05) et doit utiliser des moteurs électriques avec bague d'étanchéité côté arbre et bride d'accouplement au variateur étanche à l'huile.*

**Benchè i variatori siano abbinabili a qualsiasi motore normalizzato IEC, BONFIGLIOLI raccomanda che siano utilizzati solo motori originali, provvisti di anelli di tenuta per l'olio.**

*Although speed variators can match any IEC motors, BONFIGLIOLI recommends the use of genuine motors only, complete with shaft oil seals.*

**Es wird empfohlen, die Verstellgetriebe mit Differential mit öldichten BONFIGLIOLI RIDUTTORI Motoren zu kaufen.**

**Dans tous les cas, il est conseillé d'acquérir des variateurs avec différentiel avec moteurs avec étanchéité à l'huile BONFIGLIOLI RIDUTTORI.**

I variatori V 0.25 e V 0.5 vengono forniti completi di olio lubrificante "long life" sintetico **SHELL SPIRAX S4 ATF HDX**. Eventuali sostituzioni o rabbocchi dovranno essere effettuati utilizzando lo stesso tipo di prodotto.

*Variator units V 0.25 and V 0.5 are factory filled with "long life" synthetic oil **SHELL SPIRAX S4 ATF HDX**. Use same oil when topping up or refilling.*

Die Verstellgetriebe V 0.25 und V 0.5 werden mit Schmieröl **SHELL SPIRAX S4 ATF HDX** geliefert. Eventuelle Ölwechsel oder Nachfüllungen müssen unter Anwendung des gleichen Produkttyps erfolgen.

*Les variateurs V 0.25 et V 0.5 sont fournis avec de l'huile lubrificante "long life" **SHELL SPIRAX S4 ATF HDX**. Utiliser le même type d'huile pour les éventuels vidanges ou remplissages.*

I variatori V 1...V 10 vengono forniti completi di olio lubrificante minerale **SHELL SPIRAX S2 ATF AX**. Eventuali sostituzioni o rabbocchi potranno essere effettuati utilizzando lubrificanti compatibili.

*Variator units V 1 through V 10 are factory filled with mineral oil **SHELL SPIRAX S2 ATF AX**. Use same type of oil when topping up or refilling.*

Die Verstellgetriebe V 1...V 10 werden mit dem Schmieröl **SHELL SPIRAX S2 ATF AX** geliefert. Ein eventueller Wechsel oder ein etwaiges Auffüllen sollte unter Verwendung der Schmiermittel erfolgen.

*Les variateurs V 1...V 10 sont fournis avec de l'huile lubrificante **SHELL SPIRAX S2 ATF AX**. Utiliser le même type d'huiles pour les éventuels vidanges ou remplissages.*

Riduzione **R** lubrificata "a vita" con grasso **SHELL GADUS S5 V142W 00**.

*Helical reduction **R** is grease lubed "for life" with **SHELL GADUS S5 V142W 00**.*

Die Vorstufe **R** ist mit Fett Typ **SHELL GADUS S5 V142W 00** gefüllt.

*Réduction **R** avec lubrification permanente au moyen de graisse **SHELL GADUS S5 V142W 00**.*

Tutti i variatori sono forniti con carica di lubrificante, ad eccezione dei tipi **VD\_P(IEC)**.

*All speed variators are factory filled with lubricant, with the only exception of units type **VD\_P(IEC)**.*

Alle Verstellgetriebe sind ab Werk mit Öl gefüllt, außer dem Typ **VD\_P(IEC)**.

*Tous les variateurs sont fournis avec le lubrifiant, à l'exception des les models **VD\_P (IEC)**.*

Il tappo di sfiato, fornito a corredo, va posizionato come indicato nelle tabelle (D04 - D05).

*The breather plug, supplied along with every unit, shall be located as per the schemes (D04) and (D05).*

Der Entlüftungsstopfen, der jedem Getriebe beiligt, muss entsprechend der obige Skizze montiert werden.

*Le bouchon d'évent, fourni avec chaque variateur, doit être positionné comme indiqué dans les schémas (D04 - D05).*

 Non mescolare oli di natura diversa.

 Do not mix synthetic oil with mineral oil.

 Auf keinen Fall darf synthetisches Öl mit mineralischem gemischt werden!

 Ne pas mélanger huiles de nature différente.

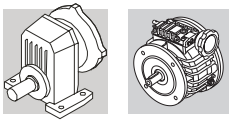

Collocazione dei tappi di carico, scarico e livello olio.

Positions of oil fill, level and drain plugs.

Anordnung des Einfüll-, Ölstands- und Ölablaßschrauben.

Position des bouchons de remplissage, niveau et vidange d'huile.

(D04)

V 0.25 - V 0.5

V 1 - V 2

B3

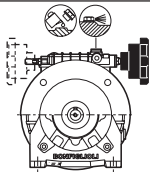

V 0.25 F	0.14	
V 0.5 F	0.18	
V 0.25 U_ / VR 0.25_	0.12	
V 0.5 U_ / VR 0.5_	0.15	
VD 0.5 U_ / VRD 0.5	0.30	

Oil SPIRAX S4 ATF HDX (for life)

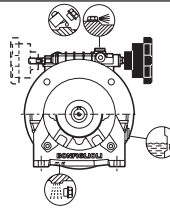

V 1 F	0.30	
V 2 F	0.40	
V 1 U_ / VR 1_	0.25	
V 2 U_ / VR 2_	0.32	
VD 1 U_ / VRD 1	0.35	
VD 2 U_ / VRD 2	0.46	

Oil SPIRAX S2 ATF AX (2000-3000 hrs.)

B6

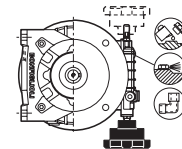

V 0.25 F	0.14	
V 0.5 F	0.18	
V 0.25 U_ / VR 0.25_	0.12	
V 0.5 U_ / VR 0.5_	0.15	
VD 0.5 U_ / VRD 0.5	0.30	

Oil SPIRAX S4 ATF HDX (for life)

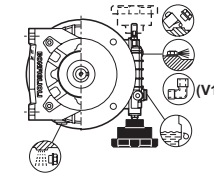

V 1 F	0.30	
V 2 F	0.40	
V 1 U_ / VR 1_	0.25	
V 2 U_ / VR 2_	0.32	
VD 1 U_ / VRD 1	0.35	
VD 2 U_ / VRD 2	0.46	

Oil SPIRAX S2 ATF AX (2000-3000 hrs.)

B7

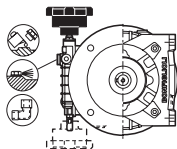

V 0.25 F	0.14	
V 0.5 F	0.18	
V 0.25 U_ / VR 0.25_	0.12	
V 0.5 U_ / VR 0.5_	0.15	
VD 0.5 U_ / VRD 0.5	0.30	

Oil SPIRAX S4 ATF HDX (for life)

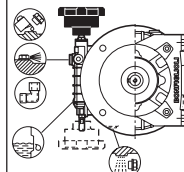

V 1 F	0.30	
V 2 F	0.40	
V 1 U_ / VR 1_	0.25	
V 2 U_ / VR 2_	0.32	
VD 1 U_ / VRD 1	0.35	
VD 2 U_ / VRD 2	0.46	

Oil SPIRAX S2 ATF AX (2000-3000 hrs.)

B8

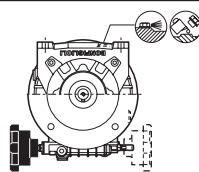

V 0.25 F	0.14	
V 0.5 F	0.18	
V 0.25 U_ / VR 0.25_	0.12	
V 0.5 U_ / VR 0.5_	0.15	
VD 0.5 U_ / VRD 0.5	0.30	

Oil SPIRAX S4 ATF HDX (for life)

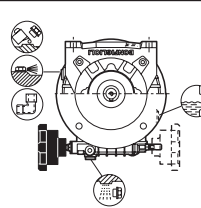

V 1 F	0.30	
V 2 F	0.40	
V 1 U_ / VR 1_	0.25	
V 2 U_ / VR 2_	0.32	
VD 1 U_ / VRD 1	0.35	
VD 2 U_ / VRD 2	0.46	

Oil SPIRAX S2 ATF AX (2000-3000 hrs.)

V5

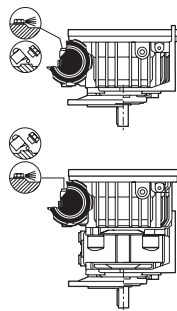

V 0.25 F	0.28	
V 0.5 F	0.30	
V 0.25 U_ / VR 0.25_	0.22	
V 0.5 U_ / VR 0.5_	0.27	

Oil SPIRAX S4 ATF HDX (for life)

VD 0.5 U_ / VRD 0.5	0.70	
---------------------	------	--

Oil SPIRAX S4 ATF HDX (for life)

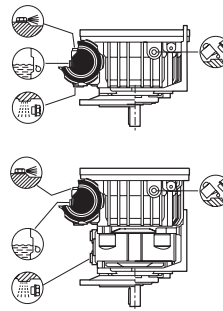

V 1 F	0.58	
V 2 F	0.78	
V 1 U_ / VR 1_	0.40	
V 2 U_ / VR 2_	0.54	

Oil SPIRAX S2 ATF AX (2000-3000 hrs.)

VD 1 U_ / VRD 1	1.00	
VD 2 U_ / VRD 2	1.5	

Oil SPIRAX S2 ATF AX (2000-3000 hrs.)

V6

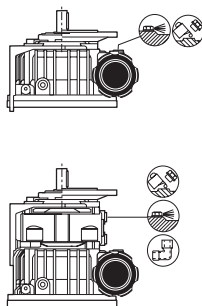

V 0.25 F	0.14	
V 0.5 F	0.18	
V 0.25 U_ / VR 0.25_	0.12	
V 0.5 U_ / VR 0.5_	0.15	

Oil SPIRAX S4 ATF HDX (for life)

VD 0.5 U_ / VRD 0.5	0.40	
---------------------	------	--

Oil SPIRAX S4 ATF HDX (for life)

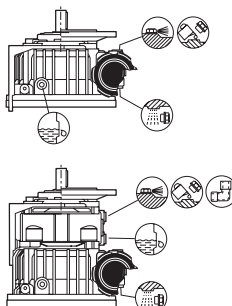

V 1 F	0.30	
V 2 F	0.40	
V 1 U_ / VR 1_	0.25	
V 2 U_ / VR 2_	0.32	

Oil SPIRAX S2 ATF AX (2000-3000 hrs.)

VD 1 U_ / VRD 1	0.50	
VD 2 U_ / VRD 2	0.70	

Oil SPIRAX S2 ATF AX (2000-3000 hrs.)

Tappo di sfiato  
Breather plug  
Entlüftungsstopfen  
Bouchon d'évent

Tappo di carico  
Filler plug  
Einfüllstopfen  
Bouchon de remplissage

Tappo di scarico  
Drain plug  
Ablasstopfen  
Bouchon de vidange

Tappo di livello  
Level plug  
Ölstandsstopfen  
Bouchon de niveau

Raccordo orientabile  
90° elbow  
90° Winkel  
Raccord coudé



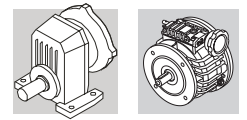

Collocazione dei tappi di carico, scarico e livello olio.

Positions of oil fill, level and drain plugs.

Anordnung des Einfüll-, Ölstands- und Ölablaßschrauben.

Position des bouchons de remplissage, niveau et vidange d'huile.

(D05)

### V 3 - V 5.5

### V 10

B3

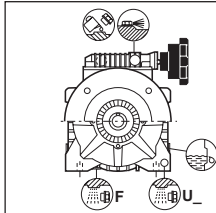

V 3 F - V 5.5 F_	0.70	
V 3 U_ / VR 3	1.0	
V 5.5 U_ / VR 5.5	1.0	
VD 3 F	1.3	
VD 5.5 F	1.3	

VD 3 U\_ / VRD 3 U  
VD 5.5 U\_ / VRD 5.5 U\_

Oil SPIRAX S2 ATF AX (2000-3000 hrs.)

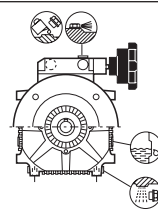

V 10 F	1.8	
V 10 U_ / VR 10		
VD 10 F	2.0	
VD 10 U_ / VRD 10 U_		

Oil SPIRAX S2 ATF AX (2000-3000 hrs.)

B6

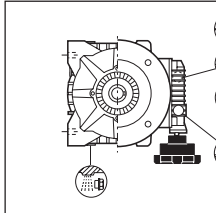

V 3 F - V 5.5 F_	0.90	
V 3 U_ / VR 3	1.0	
V 5.5 U_ / VR 5.5	1.0	
VD 3 F	1.3	
VD 5.5 F	1.3	

VD 3 U\_ / VRD 3 U  
VD 5.5 U\_ / VRD 5.5 U\_

Oil SPIRAX S2 ATF AX (2000-3000 hrs.)

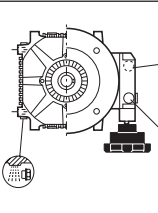

V 10 F	1.8	
V 10 U_ / VR 10		
VD 10 F	2.0	
VD 10 U_ / VRD 10 U_		

Oil SPIRAX S2 ATF AX (2000-3000 hrs.)

B7

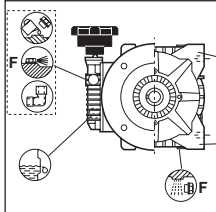

V 3 F - V 5.5 F_	0.90	
V 3 U_ / VR 3	1.0	
V 5.5 U_ / VR 5.5	1.0	
VD 3 F	1.3	
VD 5.5 F	1.3	

VD 3 U\_ / VRD 3 U  
VD 5.5 U\_ / VRD 5.5 U\_

Oil SPIRAX S2 ATF AX (2000-3000 hrs.)

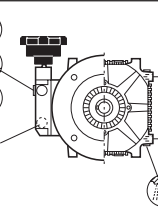

V 10 F	1.8	
V 10 U_ / VR 10		
VD 10 F	2.0	
VD 10 U_ / VRD 10 U_		

Oil SPIRAX S2 ATF AX (2000-3000 hrs.)

B8

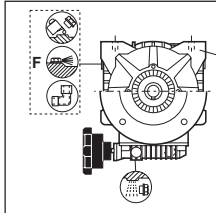

V 3 F - V 5.5 F_	1.0	
V 3 U_ / VR 3	1.3	
V 5.5 U_ / VR 5.5	1.3	
VD 3 F	1.6	
VD 5.5 F	1.6	

VD 3 U\_ / VRD 3 U  
VD 5.5 U\_ / VRD 5.5 U\_

Oil SPIRAX S2 ATF AX (2000-3000 hrs.)

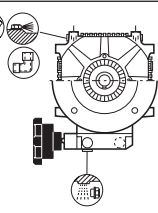

V 10 F	2.1	
V 10 U_ / VR 10		
VD 10 F	2.1	
VD 10 U_ / VRD 10 U_		

Oil SPIRAX S2 ATF AX (2000-3000 hrs.)

V5

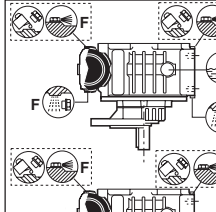

V 3 F - V 5.5 F_	2.1	
V 3 U_ / VR 3	2.0	
V 5.5 U_ / VR 5.5		

Oil SPIRAX S2 ATF AX (2000-3000 hrs.)

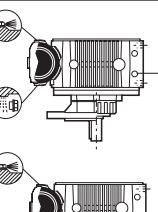

V 10 F	3.2	
V 10 U_ / VR 10		

Oil SPIRAX S2 ATF AX (2000-3000 hrs.)

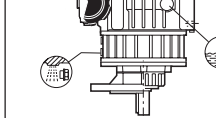

VD 3 F	4.5	
VD 5.5 F		
VD 3 U_ / VRD 3 U	4.8	
VD 5.5 U_ / VRD 5.5 U_		

Oil SPIRAX S2 ATF AX (2000-3000 hrs.)

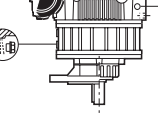

VD 10 F	8.5	
VD 10 U_ / VRD 10		

Oil SPIRAX S2 ATF AX (2000-3000 hrs.)

V6

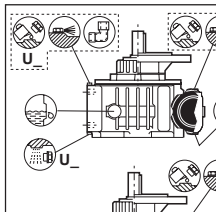

V 3 F - V 5.5 F_	1.0	
V 3 U_ / VR 3	1.3	
V 5.5 U_ / VR 5.5		

Oil SPIRAX S2 ATF AX (2000-3000 hrs.)

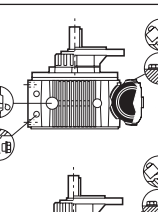

V 10 F	2.8	
V 10 U_ / VR 10		

Oil SPIRAX S2 ATF AX (2000-3000 hrs.)

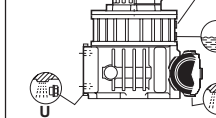

VD 3 F	2.8	
VD 5.5 F		
VD 3 U_ / VRD 3 U	3.0	
VD 5.5 U_ / VRD 5.5 U_		

Oil SPIRAX S2 ATF AX (2000-3000 hrs.)

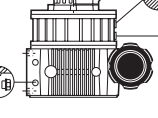

VD 10 F	7.0	
VD 10 U_ / VRD 10		

Oil SPIRAX S2 ATF AX (2000-3000 hrs.)

Tappo di sfiato  
Breather plug  
Entlüftungsstopfen  
Bouchon d'évent

Tappo di carico  
Filler plug  
Einfüllstopfen  
Bouchon de remplissage

Tappo di scarico  
Drain plug  
Ablasstopfen  
Bouchon de vidange

Tappo di livello  
Level plug  
Ölstandsstopfen  
Bouchon de niveau

Raccordo orientabile  
90° elbow  
90° Winkel  
Raccord coudé

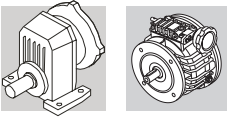

**21.8 - Posizioni di montaggio, orientamento morsetteria motore e comando variatore**

Le tabelle (D07...D09) evidenziano le posizioni che può assumere il variatore rispetto alla posizione di montaggio del riduttore.

In fase di ordine è necessario specificare oltre alla posizione di montaggio del riduttore anche la posizione del variatore, l'orientamento della morsetteria (W, N, E, S) e del comando (1, 2) scegliendo fra le alternative illustrate nelle tabelle.

La tabella (D06) facilita l'interpretazione delle varie posizioni di montaggio riportate.

**21.8 - Mounting position, motor terminal box angular position and variator control**

Tables (D07...D09) show the mounting positions of the variator depending on reducer mounting position.

Reducer mounting position and variator arrangement must be specified on order, as well as terminal board arrangement (W, N, E, S) and control position (1, 2). Choose from the options shown in the tables.

Table (D06) provides examples of the various mounting positions for better understanding.

**21.8 - Einbautagen, lage des Motorklemmenkastens und position der Steuerung des Verstellgetriebe**

Die Tabellen (D07...D09) stellen die Positionen dar, die das Verstellgetriebe den Einbautagen des Getriebes gegenüber einnehmen kann.

In der Auftragsphase muß daher über die Montageposition des Getriebes hinaus, auch die Lage des Verstellgetriebes, die Ausrichtung der Klemmenleiste (W, N, E, S) und position der Steuerung angegeben werden, die unter den in der Tabelle angegebenen Möglichkeiten ausgewählt werden können.

Die Tabelle (D06) erleichtert die Auslegung der verschiedenen, dargestellten Einbautagen.

**21.8 - Positions de montage, orientation boîte a borne du moteur et dispositif de commande variateur**

Les tableaux (D07...D09) indiquent les positions possibles du variateur par rapport à la position de montage du réducteur. Au moment de la commande, il est nécessaire de préciser la position de montage du réducteur ainsi que la position du variateur, l'orientation de la boîte à bornes (W, N, E, S) et la position du dispositif de commande (1, 2), en choisissant parmi les alternatives indiquées dans les tableaux.



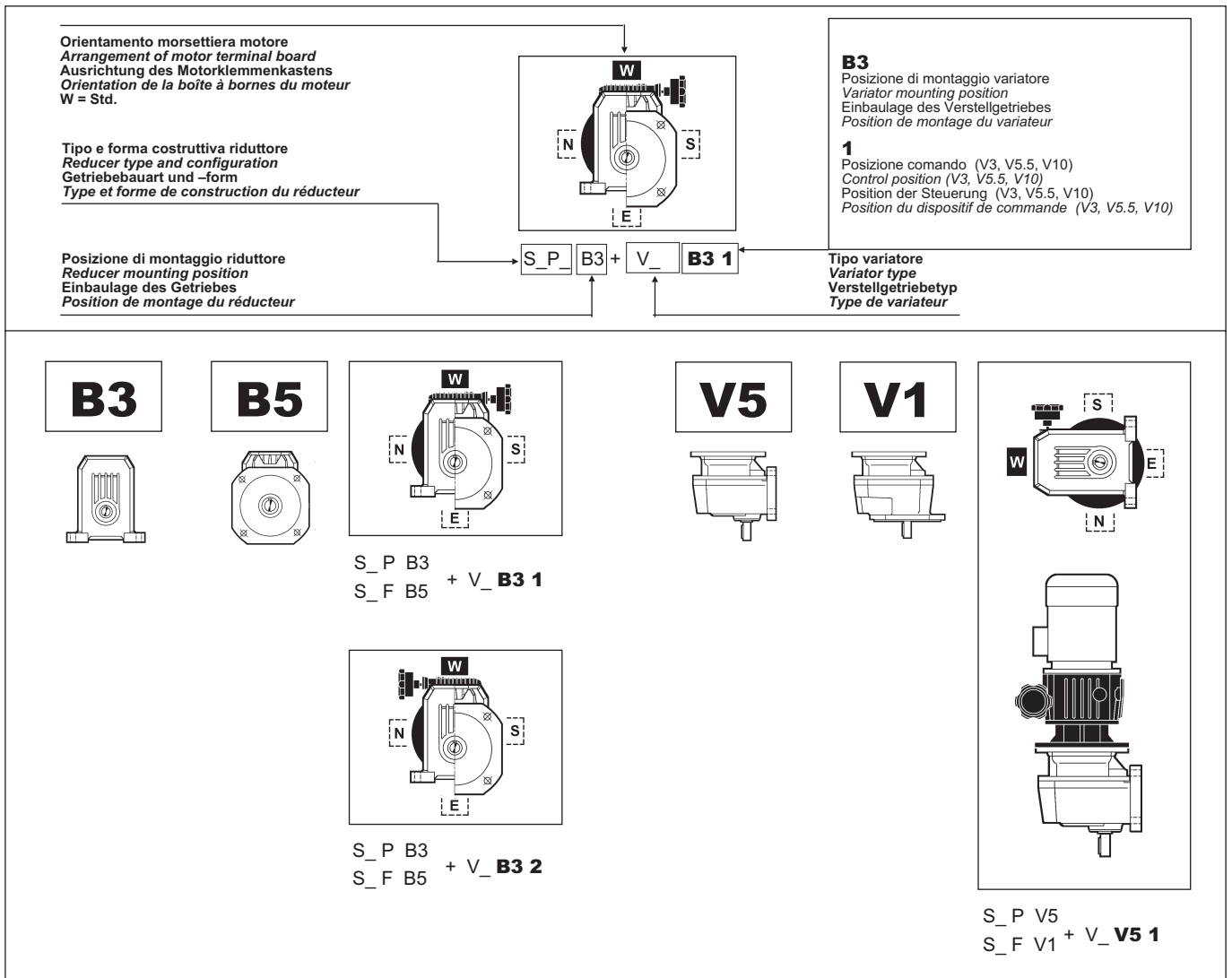

Le tableau (D06) facilite l'interprétation des différentes positions de montage indiquées.

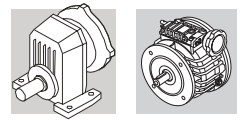
(D06)



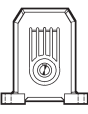
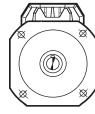
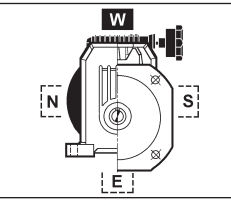
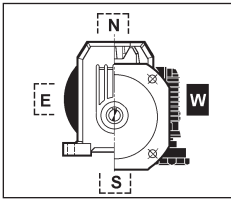
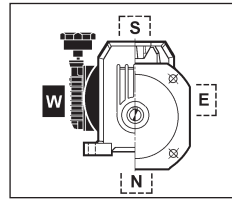
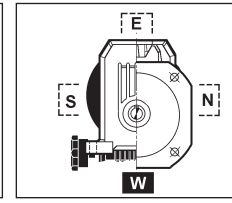
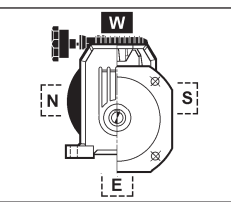
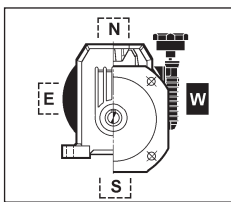
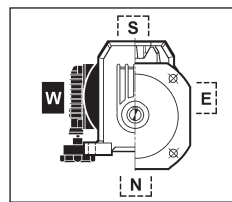
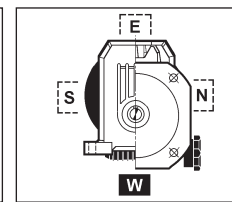

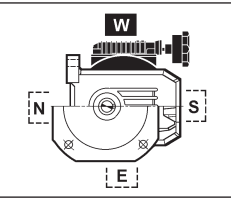
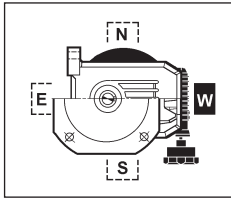
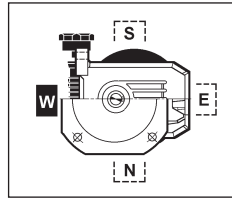
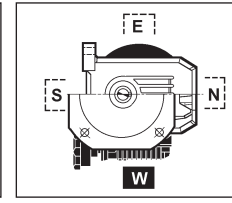
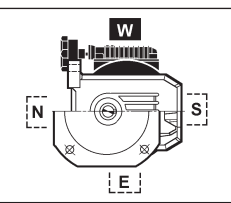
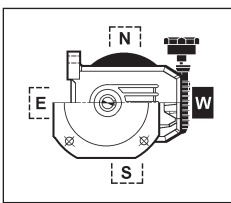
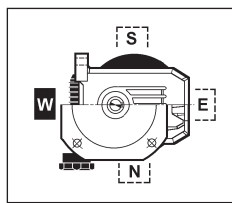
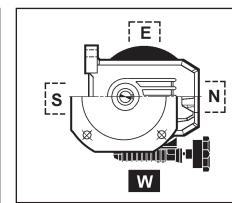
(D07)

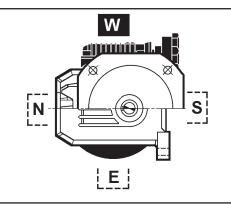
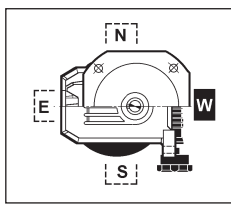
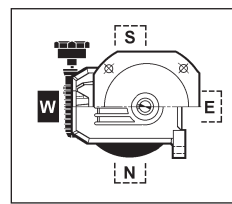
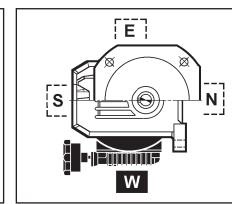
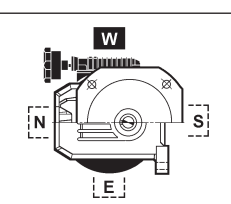
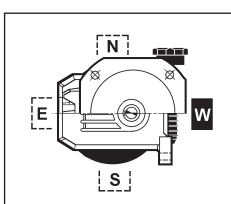
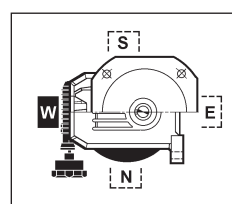
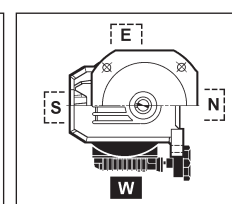
<div data-bbox="127 235 255 313" data-label="Section-Header"> <h3>B3</h3> </div> 	<div data-bbox="311 235 438 313" data-label="Section-Header"> <h3>B5</h3> </div> 	 <p>S_P B3 S_F B5 + V_ <b>B3 1</b></p>	 <p>S_P B3 S_F B5 + V_ <b>B6 1</b></p>	 <p>S_P B3 S_F B5 + V_ <b>B7 1</b></p>	 <p>S_P B3 S_F B5 + V_ <b>B8 1</b></p>
		 <p>S_P B3 S_F B5 + V_ <b>B3 2</b></p>	 <p>S_P B3 S_F B5 + V_ <b>B6 2</b></p>	 <p>S_P B3 S_F B5 + V_ <b>B7 2</b></p>	 <p>S_P B3 S_F B5 + V_ <b>B8 2</b></p>
<div data-bbox="127 862 255 940" data-label="Section-Header"> <h3>B6</h3> </div> 	<div data-bbox="311 862 438 940" data-label="Section-Header"> <h3>B51</h3> </div> 	 <p>S_P B6 S_F B51 + V_ <b>B3 1</b></p>	 <p>S_P B6 S_F B51 + V_ <b>B6 1</b></p>	 <p>S_P B6 S_F B51 + V_ <b>B7 1</b></p>	 <p>S_P B6 S_F B51 + V_ <b>B8 1</b></p>
		 <p>S_P B6 S_F B51 + V_ <b>B3 2</b></p>	 <p>S_P B6 S_F B51 + V_ <b>B6 2</b></p>	 <p>S_P B6 S_F B51 + V_ <b>B7 2</b></p>	 <p>S_P B6 S_F B51 + V_ <b>B8 2</b></p>
<div data-bbox="127 1489 255 1568" data-label="Section-Header"> <h3>B7</h3> </div> 	<div data-bbox="311 1489 438 1568" data-label="Section-Header"> <h3>B53</h3> </div> 	 <p>S_P B7 S_F B53 + V_ <b>B3 1</b></p>	 <p>S_P B7 S_F B53 + V_ <b>B6 1</b></p>	 <p>S_P B7 S_F B53 + V_ <b>B7 1</b></p>	 <p>S_P B7 S_F B53 + V_ <b>B8 1</b></p>
		 <p>S_P B7 S_F B53 + V_ <b>B3 2</b></p>	 <p>S_P B7 S_F B53 + V_ <b>B6 2</b></p>	 <p>S_P B7 S_F B53 + V_ <b>B7 2</b></p>	 <p>S_P B7 S_F B53 + V_ <b>B8 2</b></p>

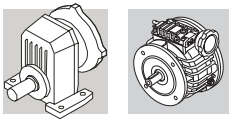

(D08)

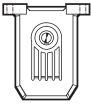
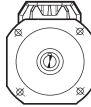
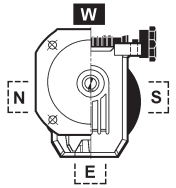
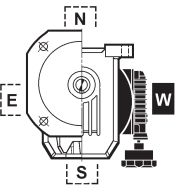
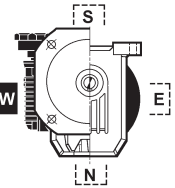
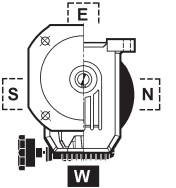
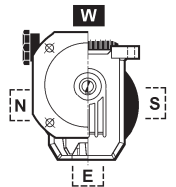
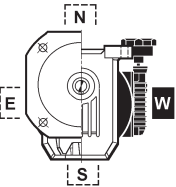
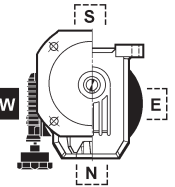
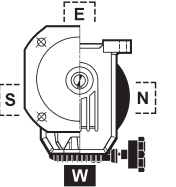
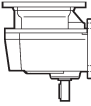
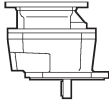
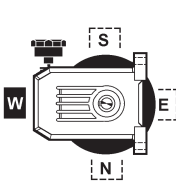
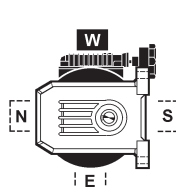
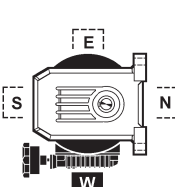
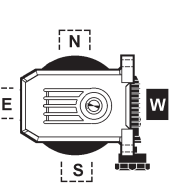
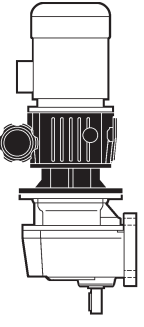
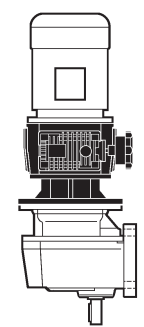
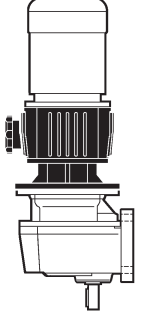
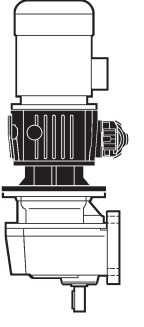
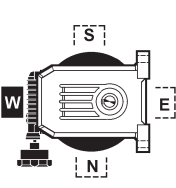
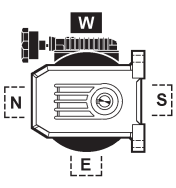
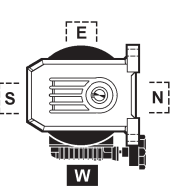
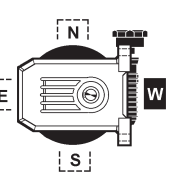
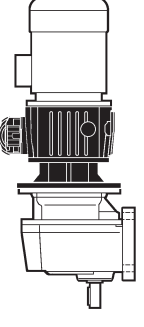
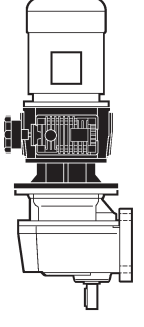
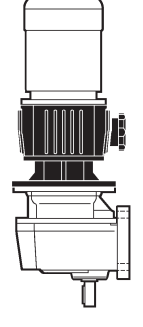
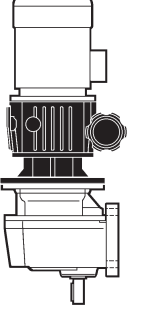
<p><b>B8</b></p> 	<p><b>B52</b></p> 				
		<p>S_P B8 S_F B52 + V_ <b>B3 1</b></p>	<p>S_P B8 S_F B52 + V_ <b>B6 1</b></p>	<p>S_P B8 S_F B52 + V_ <b>B7 1</b></p>	<p>S_P B8 S_F B52 + V_ <b>B8 1</b></p>
					
		<p>S_P B8 S_F B52 + V_ <b>B3 2</b></p>	<p>S_P B8 S_F B52 + V_ <b>B6 2</b></p>	<p>S_P B8 S_F B52 + V_ <b>B7 2</b></p>	<p>S_P B8 S_F B52 + V_ <b>B8 2</b></p>
<p><b>V5</b></p> 	<p><b>V1</b></p> 				
					
		<p>S_P V5 S_F V1 + V_ <b>V5 1</b></p>	<p>S_P V5 S_F V1 + V_ <b>V51 1</b></p>	<p>S_P V5 S_F V1 + V_ <b>V53 1</b></p>	<p>S_P V5 S_F V1 + V_ <b>V52 1</b></p>
					
					
		<p>S_P V5 S_F V1 + V_ <b>V5 2</b></p>	<p>S_P V5 S_F V1 + V_ <b>V51 2</b></p>	<p>S_P V5 S_F V1 + V_ <b>V53 2</b></p>	<p>S_P V5 S_F V1 + V_ <b>V52 2</b></p>

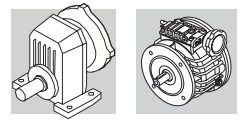

(D09)

**V6**

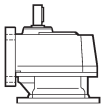

**V3**

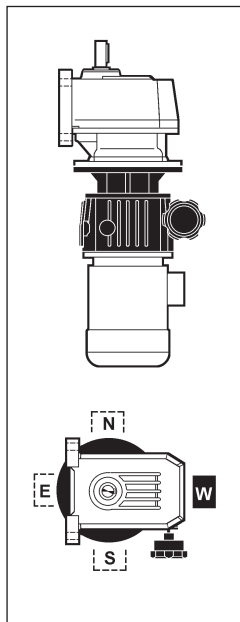
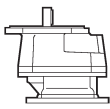

S\_P V6  
S\_F V3 + V\_ **V6 1**

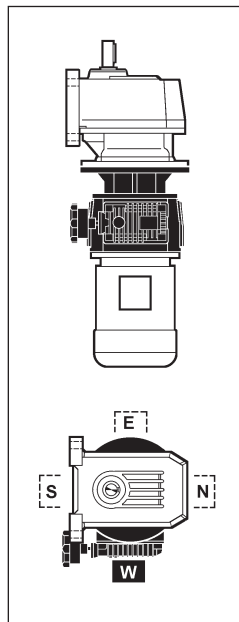

S\_P V6  
S\_F V3 + V\_ **V611**

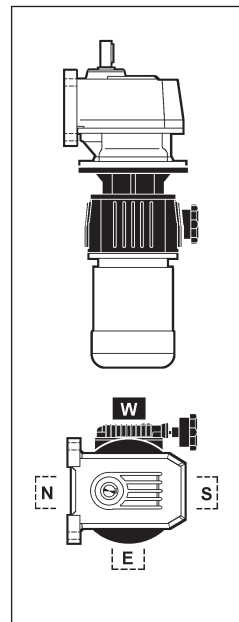

S\_P V6  
S\_F V3 + V\_ **V631**

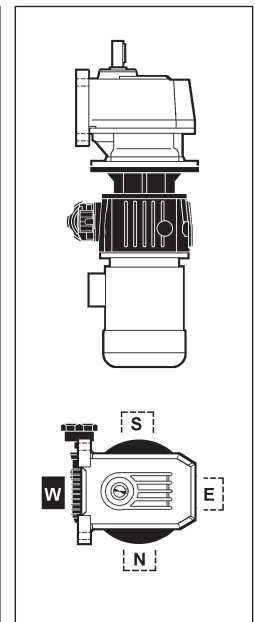

S\_P V6  
S\_F B5 + V\_ **V621**

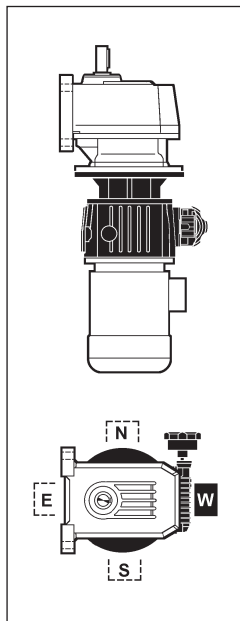

S\_P V6  
S\_F V3 + V\_ **V6 2**

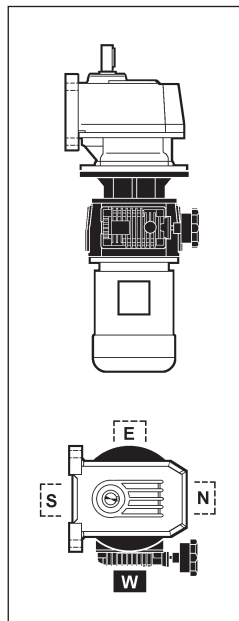

S\_P V6  
S\_F V3 + V\_ **V612**

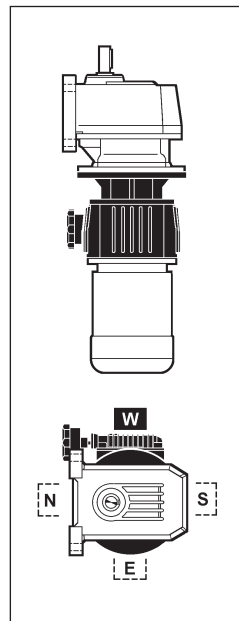

S\_P V6  
S\_F V3 + V\_ **V632**

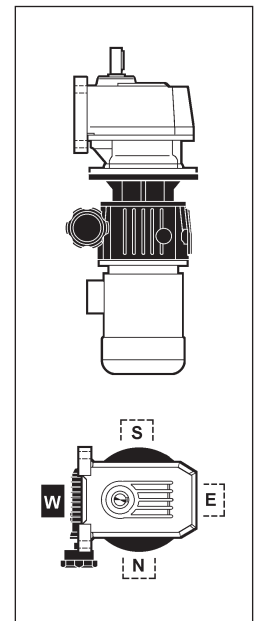

S\_P V6  
S\_F V3 + V\_ **V622**

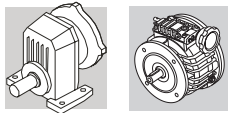







21.9 - Tabelle dati tecnici

21.9 - Selection charts

21.9 - Auswahltabellen

21.9 - Tableaux données techniques

**0.12 kW**





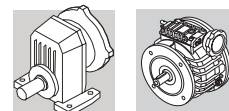

$n_2$ min <sup>-1</sup>	$n_2'$ min <sup>-1</sup>	M <sub>2</sub> Nm	M <sub>2'</sub> Nm	S	S'	i	R <sub>n2</sub> N					IEC 	
59	12.1	14.1	37	2.5	1.1	10.3	2400	S301_10.3	— P63	— V 0.25 F	P63	BN63B6	124-125
68	14.0	12.2	32	2.9	1.3	8.9	2400	S301_8.9	— P63	— V 0.25 F	P63	BN63B6	124-125
71	14.7	11.7	31	1.7	0.8	8.5	1500	S201_8.5	V025 P63	V 0.25 C V 0.25 F	P63	BN63B6	122-123
84	17.4	9.9	26	3.0	1.4	7.2	1500	S201_7.2	V025 P63	V 0.25 C V 0.25 F	P63	BN63B6	122-123
88	18.1	9.5	25	1.8	0.8	6.9	1110	S101_6.9	V025 P63	V 0.25 C V 0.25 F	P63	BN63B6	120-121
99	20.5	8.4	22	2.0	0.9	6.1	1080	S101_6.1	V025 P63	V 0.25 C V 0.25 F	P63	BN63B6	120-121
104	21.6	8.0	21	3.8	1.8	5.8	1500	S201_5.8	V025 P63	V 0.25 C V 0.25 F	P63	BN63B6	122-123
126	26.0	6.6	17.4	4.6	2.1	4.8	1500	S201_4.8	V025 P63	V 0.25 C V 0.25 F	P63	BN63B6	122-123
129	26.6	6.4	17.0	2.2	1.0	4.7	1000	S101_4.7	V025 P63	V 0.25 C V 0.25 F	P63	BN63B6	120-121
159	33	5.2	13.8	2.7	1.2	3.8	940	S101_3.8	V025 P63	V 0.25 C V 0.25 F	P63	BN63B6	120-121
189	39	4.4	11.6	3.2	1.5	3.2	890	S101_3.2	V025 P63	V 0.25 C V 0.25 F	P63	BN63B6	120-121
242	50	3.4	9.1	3.5	1.5	2.5	830	S101_2.5	V025 P63	V 0.25 C V 0.25 F	P63	BN63B6	120-121
318	66	2.6	6.9	4.6	2.0	1.9	760	S101_1.9	V025 P63	V 0.25 C V 0.25 F	P63	BN63B6	120-121
431	89	1.9	5.1	6.2	2.8	1.4	690	S101_1.4	V025 P63	V 0.25 C V 0.25 F	P63	BN63B6	120-121

**0.18 kW**

59	12.1	20	40	1.7	1.0	10.3	2400	S301_10.3	— P63	— V 0.25 F	P63	BN71A6R	124-125
68	14.0	17.4	35	2.0	1.2	8.9	2400	S301_8.9	— P63	— V 0.25 F	P63	BN71A6R	124-125
84	17.4	14.1	28	2.1	1.3	7.2	1500	S201_7.2	V025 P63	V 0.25 C V 0.25 F	P63	BN71A6R	122-123
88	18.1	13.5	27	1.3	0.8	6.9	1060	S101_6.9	V025 P63	V 0.25 C V 0.25 F	P63	BN71A6R	120-121
88	18.4	15.1	40	2.3	1.0	10.3	2400	S301_10.3	— P63	— V 0.25 F	P63	BN63B4	124-125
99	20.5	12.0	24	1.4	0.9	6.1	1030	S101_6.1	V025 P63	V 0.25 C V 0.25 F	P63	BN71A6R	120-121
102	21.3	13.1	35	2.7	1.2	8.9	2400	S301_8.9	— P63	— V 0.25 F	P63	BN63B4	124-125
126	26.4	10.6	28	2.8	1.3	7.2	1500	S201_7.2	V025 P63	V 0.25 C V 0.25 F	P63	BN63B4	122-123
129	26.6	9.2	18	1.5	0.9	4.7	960	S101_4.7	V025 P63	V 0.25 C V 0.25 F	P63	BN71A6R	120-121
132	27.5	10.0	27	1.7	0.8	6.9	940	S101_6.9	V025 P63	V 0.25 C V 0.25 F	P63	BN63B4	100-101
149	31	9.0	24	1.9	0.9	6.1	920	S101_6.1	V025 P63	V 0.25 C V 0.25 F	P63	BN63B4	120-121
157	33	8.5	23	3.5	1.6	5.8	1500	S201_5.8	V025 P63	V 0.25 C V 0.25 F	P63	BN63B4	122-123
190	40	7.1	18.8	4.3	2.0	4.8	1500	S201_4.8	V025 P63	V 0.25 C V 0.25 F	P63	BN63B4	122-123
194	40	6.9	18.4	2.0	0.9	4.7	850	S101_4.7	V025 P63	V 0.25 C V 0.25 F	P63	BN63B4	120-121



## 0.18 kW

$n_2$ min <sup>-1</sup>	$n_2'$ min <sup>-1</sup>	$M_2$ Nm	$M_2'$ Nm	S	S'	i	R <sub>n2</sub> N					IEC 	
233	49	5.7	15.3	5.2	2.4	3.9	1480	S201_3.9	V025 P63	V 0.25 C V 0.25 F	P63	BN63B4	122-123
239	50	5.6	14.9	2.5	1.1	3.8	810	S101_3.8	V025 P63	V 0.25 C V 0.25 F	P63	BN63B4	120-121
242	50	4.9	9.8	2.4	1.4	2.5	810	S101_2.5	V025 P63	V 0.25 C V 0.25 F	P63	BN71A6R	120-121
284	59	4.7	12.5	3.0	1.4	3.2	770	S101_3.2	V025 P63	V 0.25 C V 0.25 F	P63	BN63B4	120-121
318	66	3.7	7.4	3.2	1.9	1.9	740	S101_1.9	V025 P63	V 0.25 C V 0.25 F	P63	BN71A6R	120-121
364	76	3.7	9.8	3.3	1.4	2.5	710	S101_2.5	V025 P63	V 0.25 C V 0.25 F	P63	BN63B4	120-121
431	89	2.7	5.5	4.4	2.6	1.4	680	S101_1.4	V025 P63	V 0.25 C V 0.25 F	P63	BN71A6R	120-121
479	100	2.8	7.4	4.3	1.9	1.9	650	S101_1.9	V025 P63	V 0.25 C V 0.25 F	P63	BN63B4	120-121
650	136	2.1	5.5	5.8	2.6	1.4	600	S101_1.4	V025 P63	V 0.25 C V 0.25 F	P63	BN63B4	120-121

## 0.25 kW

62	11.7	31	84	1.8	0.8	10.7	3800	S401_10.7	V05 P71	V 0.5 C V 0.5 F	P71	BN71B6	126-127
77	14.5	25	67	2.8	1.3	8.6	3800	S401_8.6	V05 P71	V 0.5 C V 0.5 F	P71	BN71B6	126-127
88	18.4	18	40	1.9	1.0	10.3	2400	S301_10.3	— P63	— V 0.25 F	P63	BN63C4	124-125
92	17.4	21	56	1.4	0.7	7.2	1500	S201_7.2	V05 P71	V 0.5 C V 0.5 F	P71	BN71B6	122-123
93	17.6	21	56	2.8	1.1	7.1	2400	S301_7.1	V05 P71	V 0.5 C V 0.5 F	P71	BN71B6	124-125
93	17.8	21	52	2.8	1.3	10.7	3800	S401_10.7	V05 P71	V 0.5 C V 0.5 F	P71	BN71A4	126-127
102	21.3	15.7	35	2.2	1.2	8.9	2400	S301_8.9	— P63	— V 0.25 F	P63	BN63C4	124-125
112	21.3	17.4	44	2.0	1.0	8.9	2400	S301_8.9	V05 P71	V 0.5 C V 0.5 F	P71	BN71A4	124-125
114	21.6	17.1	45	1.8	0.8	5.8	1500	S201_5.8	V05 P71	V 0.5 C V 0.5 F	P71	BN71B6	122-123
116	22.1	16.9	42	4.2	2.0	8.6	3800	S401_8.6	V05 P71	V 0.5 C V 0.5 F	P71	BN71A4	126-127
126	26.4	12.7	28	2.4	1.3	7.2	1500	S201_7.2	V025 P63	V 0.25 C V 0.25 F	P63	BN63C4	122-123
132	27.5	12.2	27	1.4	0.8	6.9	920	S101_6.9	V025 P63	V 0.25 C V 0.25 F	P63	BN63C4	120-121
139	26.4	14.1	35	2.1	1.0	7.2	1500	S201_7.2	V05 P71	V 0.5 C V 0.5 F	P71	BN71A4	122-123
141	26.8	13.9	35	4.2	1.8	7.1	2290	S301_7.1	V05 P71	V 0.5 C V 0.5 F	P71	BN71A4	124-125
147	31	12.2	32	1.1	0.8	12.4	1500	S201_12.4	V025 P63	V 0.25 C V 0.25 F	P63	BN63B2	122-123
149	31	10.8	24	1.6	0.9	6.1	900	S101_6.1	V025 P63	V 0.25 C V 0.25 F	P63	BN63C4	120-121
157	33	10.2	23	2.9	1.6	5.8	1500	S201_5.8	V025 P63	V 0.25 C V 0.25 F	P63	BN63C4	122-123
169	35	10.8	28	1.2	0.9	10.8	1500	S201_10.8	V025 P63	V 0.25 C V 0.25 F	P63	BN63B2	122-123
170	32	11.5	31	2.6	1.2	3.9	1500	S201_3.9	V05 P71	V 0.5 C V 0.5 F	P71	BN71B6	122-123
172	33	11.4	28	2.6	1.3	5.8	1500	S201_5.8	V05 P71	V 0.5 C V 0.5 F	P71	BN71A4	122-123

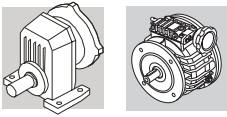





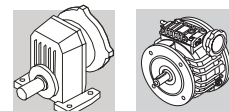

## 0.25 kW

$n_2$ min <sup>-1</sup>	$n_2'$ min <sup>-1</sup>	M <sub>2</sub> Nm	M <sub>2</sub> ' Nm	S	S'	i	R <sub>n2</sub> N					IEC	
172	33	11.4	28	5.1	2.5	5.8	2160	S301_5.8	V05 P71	V 0.5 C V 0.5 F	P71	BN71A4	124-125
190	40	8.5	19	3.5	2.0	4.8	1500	S201_4.8	V025 P63	V 0.25 C V 0.25 F	P63	BN63C4	122-123
194	40	8.3	18	1.7	0.9	4.7	840	S101_4.7	V025 P63	V 0.25 C V 0.25 F	P63	BN63C4	120-121
204	43	8.7	23	0.9	0.6	8.9	810	S101_8.9	V025 P63	V 0.25 C V 0.25 F	P63	BN63B2	120-121
208	40	9.4	24	3.2	1.6	4.8	1500	S201_4.8	V05 P71	V 0.5 C V 0.5 F	P71	BN71A4	122-123
214	45	8.3	22	1.6	1.1	8.5	1500	S201_8.5	V025 P63	V 0.25 C V 0.25 F	P63	BN63B2	122-123
233	49	6.9	15.3	4.4	2.4	3.9	1470	S201_3.9	V025 P63	V 0.25 C V 0.25 F	P63	BN63C4	122-123
239	50	6.7	14.9	2.1	1.1	3.8	790	S101_3.8	V025 P63	V 0.25 C V 0.25 F	P63	BN63C4	120-121
256	49	7.6	19.1	3.9	1.9	3.9	1410	S201_3.9	V05 P71	V 0.5 C V 0.5 F	P71	BN71A4	122-123
264	55	6.8	17.6	1.8	1.2	6.9	760	S101_6.9	V025 P63	V 0.25 C V 0.25 F	P63	BN63B2	120-121
276	52	7.1	18.8	4.3	2.0	2.4	1380	S201_2.4	V05 P71	V 0.5 C V 0.5 F	P71	BN71B6	122-123
284	59	5.6	12.5	2.5	1.4	3.2	750	S101_3.2	V025 P63	V 0.25 C V 0.25 F	P63	BN63C4	120-121
298	62	6.0	15.5	2.0	1.4	6.1	740	S101_6.1	V025 P63	V 0.25 C V 0.25 F	P63	BN63B2	120-121
323	61	6.1	15.2	4.9	2.4	3.1	1320	S201_3.1	V05 P71	V 0.5 C V 0.5 F	P71	BN71A4	122-123
349	66	5.6	14.9	3.6	1.6	1.9	1280	S201_1.9	V05 P71	V 0.5 C V 0.5 F	P71	BN71B6	122-123
364	76	4.4	9.8	2.7	1.4	2.5	700	S101_2.5	V025 P63	V 0.25 C V 0.25 F	P63	BN63C4	120-121
387	81	4.6	12.0	2.2	1.4	4.7	690	S101_4.7	V025 P63	V 0.25 C V 0.25 F	P63	BN63B2	120-121
400	76	4.9	12.3	2.4	1.1	2.5	670	S101_2.5	V05 P71	V 0.5 C V 0.5 F	P71	BN71A4	120-121
417	79	4.7	11.8	6.4	3.1	2.4	1220	S201_2.4	V05 P71	V 0.5 C V 0.5 F	P71	BN71A4	122-123
474	89	4.1	11.0	2.9	1.3	1.4	640	S101_1.4	V05 P71	V 0.5 C V 0.5 F	P71	BN71B6	120-121
479	100	3.7	9.7	2.7	1.8	3.8	650	S101_3.8	V025 P63	V 0.25 C V 0.25 F	P63	BN63B2	120-121
479	100	3.4	7.4	3.6	1.9	1.9	650	S101_1.9	V025 P63	V 0.25 C V 0.25 F	P63	BN63C4	120-121
526	100	3.7	9.3	5.4	2.6	1.9	1130	S201_1.9	V05 P71	V 0.5 C V 0.5 F	P71	BN71A4	122-123
569	119	3.1	8.2	3.2	2.1	3.2	620	S101_3.2	V025 P63	V 0.25 C V 0.25 F	P63	BN63B2	120-121
650	136	2.5	5.5	4.9	2.6	1.4	590	S101_1.4	V025 P63	V 0.25 C V 0.25 F	P63	BN63C4	120-121
714	136	2.7	6.9	4.4	2.0	1.4	600	S101_1.4	V05 P71	V 0.5 C V 0.5 F	P71	BN71A4	120-121
728	152	2.5	6.4	3.3	2.2	2.5	570	S101_2.5	V025 P63	V 0.25 C V 0.25 F	P63	BN63B2	120-121
958	200	1.9	4.8	4.3	2.9	1.9	520	S101_1.9	V025 P63	V 0.25 C V 0.25 F	P63	BN63B2	120-121
1300	271	1.4	3.8	5.8	3.9	1.4	480	S101_1.4	V025 P63	V 0.25 C V 0.25 F	P63	BN63B2	120-121









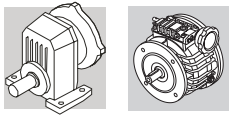

## 0.37 kW

$n_2$ min <sup>-1</sup>	$n_2'$ min <sup>-1</sup>	$M_2$ Nm	$M_2'$ Nm	S	S'	i	R <sub>n2</sub> N					IEC 	
62	11.7	42	84	1.4	0.8	10.7	3800	S401_10.7	V05 P71	V 0.5 C V 0.5 F	P71	BN71C6	126-127
77	14.5	34	67	2.1	1.3	8.6	3800	S401_8.6	V05 P71	V 0.5 C V 0.5 F	P71	BN71C6	126-127
92	17.4	28	56	1.1	0.7	7.2	1500	S201_7.2	V05 P71	V 0.5 C V 0.5 F	P71	BN71C6	122-123
93	17.6	28	56	2.1	1.1	7.1	2400	S301_7.1	V05 P71	V 0.5 C V 0.5 F	P71	BN71C6	124-125
93	17.8	31	84	1.8	0.8	10.7	3800	S401_10.7	V05 P71	V 0.5 C V 0.5 F	P71	BN71B4	126-127
114	21.6	23	45	1.3	0.8	5.8	1500	S201_5.8	V05 P71	V 0.5 C V 0.5 F	P71	BN71C6	122-123
114	21.6	23	45	2.6	1.5	5.8	2390	S301_5.8	V05 P71	V 0.5 C V 0.5 F	P71	BN71C6	124-125
116	22.1	25	67	2.8	1.3	8.6	3800	S401_8.6	V05 P71	V 0.5 C V 0.5 F	P71	BN71B4	126-127
139	26.4	21	56	1.4	0.7	7.2	1500	S201_7.2	V05 P71	V 0.5 C V 0.5 F	P71	BN71B4	122-123
139	26.4	21	56	4.3	1.6	7.2	3770	S401_7.2	V05 P71	V 0.5 C V 0.5 F	P71	BN71B4	126-127
141	26.8	21	56	2.8	1.1	7.1	2230	S301_7.1	V05 P71	V 0.5 C V 0.5 F	P71	BN71B4	124-125
164	31	17.9	48	5.9	2.3	6.1	3600	S401_6.1	V05 P71	V 0.5 C V 0.5 F	P71	BN71B4	126-127
172	33	17.1	45	1.8	0.8	5.8	1500	S201_5.8	V05 P71	V 0.5 C V 0.5 F	P71	BN71B4	122-123
172	33	17.1	45	3.4	1.5	5.8	2110	S301_5.8	V05 P71	V 0.5 C V 0.5 F	P71	BN71B4	124-125
177	37	15.1	40	1.6	1.0	10.3	2110	S301_10.3	— P63	— V 0.25 F	P63	BN63C2	124-125
204	39	14.4	38	4.0	1.8	4.9	2010	S301_4.9	V05 P71	V 0.5 C V 0.5 F	P71	BN71B4	124-125
208	40	14.1	38	2.1	1.0	4.8	1450	S201_4.8	V05 P71	V 0.5 C V 0.5 F	P71	BN71B4	122-123
253	53	10.6	28	2.0	1.3	7.2	1390	S201_7.2	V025 P63	V 0.25 C V 0.25 F	P63	BN63C2	122-123
256	49	11.5	31	2.6	1.2	3.9	1370	S201_3.9	V05 P71	V 0.5 C V 0.5 F	P71	BN71B4	122-123
264	55	10.1	27	1.2	0.8	6.9	720	S101_6.9	V025 P63	V 0.25 C V 0.25 F	P63	BN63C2	120-121
298	62	9.0	24	1.3	0.9	6.1	710	S101_6.1	V025 P63	V 0.25 C V 0.25 F	P63	BN63C2	120-121
323	61	9.1	24	3.3	1.5	3.1	1280	S201_3.1	V05 P71	V 0.5 C V 0.5 F	P71	BN71B4	122-123
387	81	6.9	18.4	1.4	0.9	4.7	660	S101_4.7	V025 P63	V 0.25 C V 0.25 F	P63	BN63C2	120-121
417	79	7.1	18.8	4.3	2.0	2.4	1200	S201_2.4	V05 P71	V 0.5 C V 0.5 F	P71	BN71B4	122-123
467	97	5.7	15.3	3.7	2.4	3.9	1160	S201_3.9	V025 P63	V 0.25 C V 0.25 F	P63	BN63C2	122-123
479	100	5.6	14.9	1.8	1.1	3.8	630	S101_3.8	V025 P63	V 0.25 C V 0.25 F	P63	BN63C2	120-121
526	100	5.6	14.9	3.6	1.6	1.9	1110	S201_1.9	V05 P71	V 0.5 C V 0.5 F	P71	BN71B4	122-123
569	119	4.7	12.5	2.1	1.4	3.2	600	S101_3.2	V025 P63	V 0.25 C V 0.25 F	P63	BN63C2	120-121
714	136	4.1	11.0	2.9	1.3	1.4	550	S101_1.4	V05 P71	V 0.5 C V 0.5 F	P71	BN71B4	120-121
728	152	3.7	9.8	2.2	1.4	2.5	560	S101_2.5	V025 P63	V 0.25 C V 0.25 F	P63	BN63C2	120-121
958	200	2.8	7.4	2.9	1.9	1.9	510	S101_1.9	V025 P63	V 0.25 C V 0.25 F	P63	BN63C2	120-121
1300	271	2.1	5.5	3.9	2.6	1.4	470	S101_1.4	V025 P63	V 0.25 C V 0.25 F	P63	BN63C2	120-121







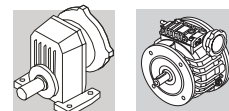

## 0.55 kW

$n_2$ min <sup>-1</sup>	$n_2'$ min <sup>-1</sup>	M <sub>2</sub> Nm	M <sub>2'</sub> Nm	S	S'	i	R <sub>n2</sub> N					IEC 	
75	14.2	52	138	2.4	0.9	8.8	6260	S501_8.8	—	—	P80	BN80B6	128-129
77	14.5	51	67	1.4	1.3	8.6	3800	S401_8.6	V05 P71	V 0.5 C V 0.5 F	P80	BN80B6	126-127
77	14.5	51	135	1.4	0.6	8.6	3800	S401_8.6	V1 P80	V 1 C V 1 F	P80	BN80B6	126-127
92	17.4	42	56	2.1	1.6	7.2	3800	S401_7.2	V05 P71	V 0.5 C V 0.5 F	P80	BN80B6	126-127
92	17.4	42	113	2.1	0.8	7.2	3800	S401_7.2	V1 P80	V 1 C V 1 F	P80	BN80B6	126-127
93	17.6	42	56	1.4	1.1	7.1	2400	S301_7.1	V05 P71	V 0.5 C V 0.5 F	P80	BN80B6	124-125
93	17.6	42	111	1.4	0.6	7.1	2400	S301_7.1	V1 P80	V 1 C V 1 F	P80	BN80B6	124-125
109	20.5	36	48	2.9	2.3	6.1	3800	S401_6.1	V05 P71	V 0.5 C V 0.5 F	P80	BN80B6	126-127
109	20.5	36	96	2.9	1.2	6.1	3800	S401_6.1	V1 P80	V 1 C V 1 F	P80	BN80B6	126-127
114	21.6	34	45	1.7	1.5	5.8	2300	S301_5.8	V05 P71	V 0.5 C V 0.5 F	P80	BN80B6	124-125
114	21.6	34	91	1.7	0.8	5.8	2300	S301_5.8	V1 P80	V 1 C V 1 F	P80	BN80B6	124-125
116	22.1	38	67	1.8	1.3	8.6	3800	S401_8.6	V05 P71	V 0.5 C V 0.5 F	P80	BN80A4	126-127
116	22.1	38	101	1.8	0.8	8.6	3800	S401_8.6	V1 P80	V 1 C V 1 F	P80	BN80A4	126-127
135	25.5	29	38	2.0	1.8	4.9	2200	S301_4.9	V05 P71	V 0.5 C V 0.5 F	P80	BN80B6	124-125
135	25.5	29	77	2.0	0.9	4.9	2200	S301_4.9	V1 P80	V 1 C V 1 F	P80	BN80B6	124-125
139	26.4	32	56	2.8	1.6	7.2	3720	S401_7.2	V05 P71	V 0.5 C V 0.5 F	P80	BN80A4	126-127
139	26.4	32	85	2.8	1.1	7.2	3720	S401_7.2	V1 P80	V 1 C V 1 F	P80	BN80A4	126-127
141	26.8	31	56	1.9	1.1	7.1	2400	S301_7.1	V05 P71	V 0.5 C V 0.5 F	P80	BN80A4	124-125
164	31	27	48	3.9	2.3	6.1	3530	S401_6.1	V05 P71	V 0.5 C V 0.5 F	P80	BN80A4	126-127
164	31	27	72	3.9	1.5	6.1	3530	S401_6.1	V1 P80	V 1 C V 1 F	P80	BN80A4	126-127
172	33	26	45	2.3	1.5	5.8	2040	S301_5.8	V05 P71	V 0.5 C V 0.5 F	P80	BN80A4	124-125
172	33	26	68	2.3	1.0	5.8	2040	S301_5.8	V1 P80	V 1 C V 1 F	P80	BN80A4	124-125
187	36	21	52	1.9	1.3	10.7	3410	S401_10.7	V05 P71	V 0.5 C V 0.5 F	P71	BN71B2	126-127
194	37	20	50	1.2	0.8	10.3	2000	S301_10.3	V05 P71	V 0.5 C V 0.5 F	P71	BN71B2	124-125
204	39	22	38	2.7	1.8	4.9	1950	S301_4.9	V05 P71	V 0.5 C V 0.5 F	P80	BN80A4	124-125
204	39	22	58	2.7	1.2	4.9	1950	S301_4.9	V1 P80	V 1 C V 1 F	P80	BN80A4	124-125
225	43	17.4	44	1.4	1.0	8.9	1910	S301_8.9	V05 P71	V 0.5 C V 0.5 F	P71	BN71B2	124-125
256	49	17.2	46	3.4	1.5	3.9	1830	S301_3.9	V1 P80	V 1 C V 1 F	P80	BN80A4	124-125
278	53	14.1	35	1.5	1.0	7.2	1310	S201_7.2	V05 P71	V 0.5 C V 0.5 F	P71	BN71B2	122-123
282	54	13.9	35	2.9	1.8	7.1	1790	S301_7.1	V05 P71	V 0.5 C V 0.5 F	P71	BN71B2	124-125
323	61	13.7	36	4.2	1.9	3.1	1170	S301_3.1	V1 P80	V 1 C V 1 F	P80	BN80A4	124-125
345	66	11.4	28	1.8	1.3	5.8	1240	S201_5.8	V05 P71	V 0.5 C V 0.5 F	P71	BN71B2	122-123
417	79	10.6	19	2.8	2.0	2.4	1160	S201_2.4	V05 P71	V 0.5 C V 0.5 F	P80	BN80A4	122-123
417	79	10.6	28	5.5	2.5	2.4	1580	S301_2.4	V1 P80	V 1 C V 1 F	P80	BN80A4	124-125
474	89	8.2	11.0	1.5	1.3	1.4	570	S101_1.4	V05 P71	V 0.5 C V 0.5 F	P80	BN80B6	120-121
474	89	8.2	22	4.3	1.9	1.4	1520	S301_1.4	V1 P80	V 1 C V 1 F	P80	BN80B6	124-125
513	97	7.6	19.1	2.7	1.9	3.9	1110	S201_3.9	V05 P71	V 0.5 C V 0.5 F	P71	BN71B2	122-123
526	100	8.4	14.9	1.4	0.9	1.9	550	S101_1.9	V05 P71	V 0.5 C V 0.5 F	P80	BN80A4	120-121



## 0.55 kW

$n_2$ min <sup>-1</sup>	$n_2'$ min <sup>-1</sup>	M <sub>2</sub> Nm	M <sub>2'</sub> Nm	S	S'	i	R <sub>n2</sub> N					IEC 	
556	106	7.9	21	4.4	2.0	1.8	1450	S301_1.8	V1 P80	V 1 C V 1 F	P80	BN80A4	124-125
625	119	6.3	15.7	1.6	1.1	3.2	550	S101_3.2	V05 P71	V 0.5 C V 0.5 F	P71	BN71B2	120-121
645	123	6.1	15.2	3.5	2.4	3.1	1030	S201_3.1	V05 P71	V 0.5 C V 0.5 F	P71	BN71B2	122-123
714	136	6.2	11.0	1.9	1.3	1.4	520	S101_1.4	V05 P71	V 0.5 C V 0.5 F	P80	BN80A4	120-121
714	136	6.2	16.5	3.2	1.5	1.4	980	S201_1.4	— P80	— V 1 F	P80	BN80A4	122-123
714	136	6.2	16.5	5.7	2.6	1.4	1340	S301_1.4	V1 P80	V 1 C V 1 F	P80	BN80A4	124-125
800	152	4.9	12.3	1.6	1.1	2.5	520	S101_2.5	V05 P71	V 0.5 C V 0.5 F	P71	BN71B2	120-121
833	158	4.7	11.8	4.5	3.1	2.4	960	S201_2.4	V05 P71	V 0.5 C V 0.5 F	P71	BN71B2	122-123
1053	200	3.7	9.3	2.1	1.5	1.9	480	S101_1.9	V05 P71	V 0.5 C V 0.5 F	P71	BN71B2	120-121
1053	200	3.7	9.3	3.5	2.6	1.9	890	S201_1.9	V05 P71	V 0.5 C V 0.5 F	P71	BN71B2	122-123
1429	271	2.7	6.9	2.9	2.0	1.4	440	S101_1.4	V05 P71	V 0.5 C V 0.5 F	P71	BN71B2	120-121

## 0.75 kW

63	11.9	82	165	1.4	0.7	10.5	6520	S501_10.5	— P80	— V 1 F	P80	BN80C6	128-129
75	14.2	69	138	1.8	0.9	8.8	6190	S501_8.8	— P80	— V 1 F	P80	BN80C6	128-129
92	17.4	56	113	1.6	0.8	7.2	3800	S401_7.2	V1 P80	V 1 C V 1 F	P80	BN80C6	126-127
93	17.6	56	111	1.0	0.6	7.1	2310	S301_7.1	V1 P80	V 1 C V 1 F	P80	BN80C6	124-125
95	18.1	62	165	1.9	0.7	10.5	5730	S501_10.5	— P80	— V 1 F	P80	BN80B4	128-129
109	20.5	48	96	2.2	1.2	6.1	3800	S401_6.1	V1 P80	V 1 C V 1 F	P80	BN80C6	126-127
114	21.6	45	91	1.3	0.8	5.8	2210	S301_5.8	V1 P80	V 1 C V 1 F	P80	BN80C6	124-125
135	25.5	38	77	1.5	0.9	4.9	2130	S301_4.9	V1 P80	V 1 C V 1 F	P80	BN80C6	124-125
139	26.4	42	113	2.1	0.8	7.2	3660	S401_7.2	V1 P80	V 1 C V 1 F	P80	BN80B4	126-127
141	26.8	42	111	1.4	0.6	7.1	2070	S301_7.1	V1 P80	V 1 C V 1 F	P80	BN80B4	124-125
164	31	36	96	2.9	1.2	6.1	3480	S401_6.1	V1 P80	V 1 C V 1 F	P80	BN80B4	126-127
170	32	31	61	1.9	1.1	3.9	2010	S301_3.9	V1 P80	V 1 C V 1 F	P80	BN80C6	124-125
172	33	34	91	1.7	0.8	5.8	1980	S301_5.8	V1 P80	V 1 C V 1 F	P80	BN80B4	124-125
187	36	31	84	1.3	0.8	10.7	3350	S401_10.7	V05 P71	V 0.5 C V 0.5 F	P71	BN71C2	126-127
204	39	29	77	2.0	0.9	4.9	1890	S301_4.9	V1 P80	V 1 C V 1 F	P80	BN80B4	124-125
208	40	28	38	1.1	1.0	4.8	1310	S201_4.8	V05 P71	V 0.5 C V 0.5 F	P80	BN80B4	122-123
208	40	28	75	3.7	1.7	4.8	3250	S401_4.8	V1 P80	V 1 C V 1 F	P80	BN80B4	126-127
214	40	24	49	2.4	1.4	3.1	1880	S301_3.1	V1 P80	V 1 C V 1 F	P80	BN80C6	124-125
256	49	23	31	1.3	1.2	3.9	1250	S201_3.9	V05 P71	V 0.5 C V 0.5 F	P80	BN80B4	122-123
256	49	23	61	2.5	1.1	3.9	1780	S301_3.9	V1 P80	V 1 C V 1 F	P80	BN80B4	124-125

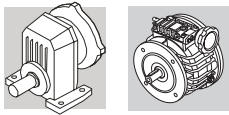

## 0.75 kW





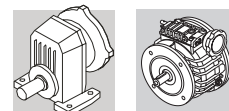

$n_2$ min <sup>-1</sup>	$n_2'$ min <sup>-1</sup>	M <sub>2</sub> Nm	M <sub>2'</sub> Nm	S	S'	i	R <sub>n2</sub> N						
263	50	22	60	4.7	2.1	3.8	3020	S401_3.8	V1 P80	V 1 C V 1 F	P80	BN80B4	126-127
278	53	21	56	3.0	1.6	7.2	2970	S401_7.2	V05 P71	V 0.5 C V 0.5 F	P71	BN71C2	126-127
282	54	21	56	1.9	1.1	7.1	1740	S301_7.1	V05 P71	V 0.5 C V 0.5 F	P71	BN71C2	124-125
323	61	18.2	24	1.6	1.5	3.1	1180	S201_3.1	V05 P71	V 0.5 C V 0.5 F	P80	BN80B4	122-123
323	61	18.2	49	3.2	1.4	3.1	1660	S301_3.1	V1 P80	V 1 C V 1 F	P80	BN80B4	124-125
345	66	17.1	45	1.2	0.8	5.8	1180	S201_5.8	V05 P71	V 0.5 C V 0.5 F	P71	BN71C2	122-123
368	69	14.1	28	2.5	1.5	1.8	1620	S301_1.8	V1 P80	V 1 C V 1 F	P80	BN80C6	124-125
417	79	14.1	38	1.5	1.0	4.8	1120	S201_4.8	V05 P71	V 0.5 C V 0.5 F	P71	BN71C2	122-123
417	79	14.1	18.8	2.1	2.0	2.4	1120	S201_2.4	V05 P71	V 0.5 C V 0.5 F	P80	BN80B4	122-123
417	79	14.1	38	4.1	1.9	2.4	1550	S301_2.4	V1 P80	V 1 C V 1 F	P80	BN80B4	124-125
474	89	11.0	22	3.2	1.9	1.4	1500	S301_1.4	V1 P80	V 1 C V 1 F	P80	BN80C6	124-125
513	97	11.5	31	1.8	1.2	3.9	1060	S201_3.9	V05 P71	V 0.5 C V 0.5 F	P71	BN71C2	122-123
513	97	11.5	31	3.5	2.3	3.9	1470	S301_3.9	V05 P71	V 0.5 C V 0.5 F	P71	BN71C2	124-125
526	100	11.2	14.9	1.8	1.6	1.9	1050	S201_1.9	V05 P71	V 0.5 C V 0.5 F	P80	BN80B4	122-123
556	106	10.6	28	3.3	1.5	1.8	1430	S301_1.8	V1 P80	V 1 C V 1 F	P80	BN80B4	124-125
645	123	9.1	24	2.3	1.5	3.1	1000	S201_3.1	V05 P71	V 0.5 C V 0.5 F	P71	BN71C2	122-123
714	136	8.2	11.0	2.4	2.2	1.4	960	S201_1.4	V05 —	V 0.5 C —	P80	BN80B4	122-123
714	136	8.2	22	4.3	1.9	1.4	1320	S301_1.4	V1 P80	V 1 C V 1 F	P80	BN80B4	124-125
833	158	7.1	18.8	3.0	2.0	2.4	930	S201_2.4	V05 P71	V 0.5 C V 0.5 F	P71	BN71C2	122-123
1053	200	5.6	14.9	2.3	1.6	1.9	870	S201_1.9	V05 P71	V 0.5 C V 0.5 F	P71	BN71C2	122-123
1429	271	4.1	11.0	1.9	1.3	1.4	420	S101_1.4	V05 P71	V 0.5 C V 0.5 F	P71	BN71C2	120-121

## 1.1 kW

57	11.9	123	165	0.9	0.7	10.5	6330	S501_10.5	— P80	— V 1 F	P90	BN90L6	128-129
68	14.2	103	138	1.2	0.9	8.8	6030	S501_8.8	— P80	— V 1 F	P90	BN90L6	128-129
81	16.9	87	116	1.6	1.2	7.4	5740	S501_7.4	— P80	— V 1 F	P90	BN90L6	128-129
90	16.9	87	232	1.6	0.6	7.4	5740	S501_7.4	V2 P90	V 2 C V 2 F	P90	BN90L6	128-129
102	21.6	78	138	1.6	0.9	8.8	5320	S501_8.8	— P80	— V 1 F	P90	BN90S4	128-129
109	20.5	72	191	1.5	0.6	6.1	3800	S401_6.1	V2 P90	V 2 C V 2 F	P90	BN90L6	126-127
109	20.5	72	191	2.1	0.8	6.1	5420	S501_6.1	V2 P90	V 2 C V 2 F	P90	BN90L6	128-129
135	25.7	65	174	2.1	0.8	7.4	5050	S501_7.4	V2 P90	V 2 C V 2 F	P90	BN90S4	128-129







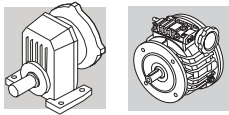

# 1.1 kW

$n_2$ min <sup>-1</sup>	$n_2'$ min <sup>-1</sup>	M <sub>2</sub> Nm	M <sub>2'</sub> Nm	S	S'	i	R <sub>n2</sub> N					IEC 	
138	26.0	56	151	1.9	0.8	4.8	2590	S401_4.8	V2 P90	V 2 C V 2 F	P90	BN90L6	126-127
164	31	54	143	2.0	0.8	6.1	3380	S401_6.1	V2 P90	V 2 C V 2 F	P90	BN90S4	126-127
164	31	54	143	2.8	1.0	6.1	4760	S501_6.1	V2 P90	V 2 C V 2 F	P90	BN90S4	128-129
184	39	44	77	1.3	0.9	4.9	1780	S301_4.9	V1 P80	V 1 C V 1 F	P90	BN90S4	124-125
190	36	46	123	1.8	0.9	10.5	4560	S501_10.5	— P80	— V 1 F	P80	BN80B2	128-129
208	40	42	113	2.5	1.1	4.8	3170	S401_4.8	V2 P90	V 2 C V 2 F	P90	BN90S4	126-127
208	40	42	113	4.1	1.6	4.8	4420	S501_4.8	V2 P90	V 2 C V 2 F	P90	BN90S4	128-129
227	43	39	103	2.2	1.2	8.8	4320	S501_8.8	— P80	— V 1 F	P80	BN80B2	128-129
233	44	38	101	1.3	0.8	8.6	3080	S401_8.6	V1 P80	V 1 C V 1 F	P80	BN80B2	126-127
263	50	34	89	3.1	1.4	3.8	2960	S401_3.8	V2 P90	V 2 C V 2 F	P90	BN90S4	126-127
263	50	34	89	5.2	2.2	3.8	4140	S501_3.8	V2 P90	V 2 C V 2 F	P90	BN90S4	128-129
282	54	31	83	1.3	0.7	7.1	1660	S301_7.1	V1 P80	V 1 C V 1 F	P80	BN80B2	124-125
323	61	27	73	3.8	1.7	3.1	2770	S401_3.1	V2 P90	V 2 C V 2 F	P90	BN90S4	126-127
328	62	27	72	2.6	1.5	6.1	2770	S401_6.1	V1 P80	V 1 C V 1 F	P80	BN80B2	126-127
345	66	26	68	1.6	1.0	5.8	1580	S301_5.8	V1 P80	V 1 C V 1 F	P80	BN80B2	124-125
349	66	22	60	3.1	1.4	1.9	2700	S401_1.9	V2 P90	V 2 C V 2 F	P90	BN90L6	126-127
408	78	22	58	1.9	1.2	4.9	1510	S301_4.9	V1 P80	V 1 C V 1 F	P80	BN80B2	124-125
474	89	16.5	44	2.1	1.0	1.4	1450	S301_1.4	— P90	— V 2 F	P90	BN90L6	124-125
474	89	16.5	44	4.3	1.9	1.4	2440	S401_1.4	V2 P90	V 2 C V 2 F	P90	BN90L6	126-127
513	97	17.2	46	2.3	1.5	3.9	1420	S301_3.9	V1 P80	V 1 C V 1 F	P80	BN80B2	124-125
526	100	16.8	45	4.2	1.9	1.9	2370	S401_1.9	V2 P90	V 2 C V 2 F	P90	BN90S4	126-127
645	123	13.7	36	1.5	1.0	3.1	950	S201_3.1	— P80	— V 1 F	P80	BN80B2	122-123
645	123	13.7	24	1.5	1.5	3.1	950	S201_3.1	V05 P71	V 0.5 C V 0.5 F	P80	BN80B2	122-123
645	123	13.7	36	2.9	1.9	3.1	1320	S301_3.1	V1 P80	V 1 C V 1 F	P80	BN80B2	124-125
714	136	12.3	33	5.7	2.6	1.4	2160	S401_1.4	V2 P90	V 2 C V 2 F	P90	BN90S4	126-127
833	158	10.6	28	2.0	1.3	2.4	890	S201_2.4	— P80	— V 1 F	P80	BN80B2	122-123
833	158	10.6	28	3.8	2.5	2.4	1240	S301_2.4	V1 P80	V 1 C V 1 F	P80	BN80B2	124-125
1053	200	8.4	22	1.6	1.1	1.9	840	S201_1.9	— P80	— V 1 F	P80	BN80B2	122-123
1111	211	7.9	21	3.0	2.0	1.8	1140	S301_1.8	V1 P80	V 1 C V 1 F	P80	BN80B2	124-125
1429	271	6.2	16.5	2.1	1.5	1.4	770	S201_1.4	— P80	— V 1 F	P80	BN80B2	122-123







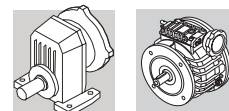

# 1.5 kW

$n_2$ min <sup>-1</sup>	$n_2'$ min <sup>-1</sup>	M <sub>2</sub> Nm	M <sub>2</sub> ' Nm	S	S'	i	R <sub>N2</sub> N					IEC 	
90	16.9	116	254	1.2	0.6	7.4	5610	S501_7.4	V2 P90	V 2 C V 2 F	P90	BN100LA6R	128-129
109	20.5	96	209	1.1	0.5	6.1	3630	S401_6.1	V2 P90	V 2 C V 2 F	P90	BN100LA6R	126-127
109	20.5	96	209	1.6	0.7	6.1	5310	S501_6.1	V2 P90	V 2 C V 2 F	P90	BN100LA6R	128-129
138	26.0	75	165	1.4	0.8	4.8	3480	S401_4.8	V2 P90	V 2 C V 2 F	P90	BN100LA6R	126-127
138	26.0	75	165	2.3	1.1	4.8	4940	S501_4.8	V2 P90	V 2 C V 2 F	P90	BN100LA6R	128-129
164	31	72	191	1.5	0.6	6.1	3280	S401_6.1	V2 P90	V 2 C V 2 F	P90	BN90LA4	126-127
164	31	72	191	2.1	0.8	6.1	4680	S501_6.1	V2 P90	V 2 C V 2 F	P90	BN90LA4	128-129
174	33	60	130	1.8	1.0	3.8	3270	S401_3.8	V2 P90	V 2 C V 2 F	P90	BN100LA6R	126-127
208	40	56	151	1.9	0.8	4.8	3090	S401_4.8	V2 P90	V 2 C V 2 F	P90	BN90LA4	126-127
208	40	56	151	3.1	1.2	4.8	4350	S501_4.8	V2 P90	V 2 C V 2 F	P90	BN90LA4	128-129
227	43	52	138	1.6	0.9	8.8	4260	S501_8.8	— P80	— V 1 F	P80	BN80C2	128-129
231	49	46	61	1.3	1.1	3.9	1590	S301_3.9	V1 P80	V 1 C V 1 F	P90	BN90LA4	124-125
237	50	45	60	2.3	2.1	3.8	2890	S401_3.8	V1 P80	V 1 C V 1 F	P90	BN90LA4	126-127
263	50	45	119	2.3	1.0	3.8	2890	S401_3.8	V2 P90	V 2 C V 2 F	P90	BN90LA4	126-127
263	50	45	119	3.9	1.7	3.8	4090	S501_3.8	V2 P90	V 2 C V 2 F	P90	BN90LA4	128-129
276	52	38	82	2.8	1.5	2.4	2870	S401_2.4	V2 P90	V 2 C V 2 F	P90	BN100LA6R	126-127
282	54	42	56	1.0	1.1	7.1	1580	S301_7.1	V05 P71	V 0.5 C V 0.5 F	P80	BN80C2	124-125
323	61	36	97	2.9	1.3	3.1	2710	S401_3.1	V2 P90	V 2 C V 2 F	P90	BN90LA4	126-127
345	66	34	45	1.2	1.5	5.8	1510	S301_5.8	V05 P71	V 0.5 C V 0.5 F	P80	BN80C2	124-125
349	66	30	65	2.3	1.3	1.9	2660	S401_1.9	V2 P90	V 2 C V 2 F	P90	BN100LA6R	126-127
408	78	29	77	1.4	0.9	4.9	1450	S301_4.9	V1 P80	V 1 C V 1 F	P80	BN80C2	124-125
408	78	29	38	1.4	1.8	4.9	1450	S301_4.9	V05 P71	V 0.5 C V 0.5 F	P80	BN80C2	124-125
417	79	28	75	3.7	1.7	2.4	2530	S401_2.4	V2 P90	V 2 C V 2 F	P90	BN90LA4	126-127
474	89	22	48	1.6	0.9	1.4	1390	S301_1.4	— P90	— V 2 F	P90	BN100LA6R	124-125
474	89	22	48	3.2	1.8	1.4	2430	S401_1.4	V2 P90	V 2 C V 2 F	P90	BN100LA6R	126-127
513	97	23	61	1.7	1.1	3.9	1380	S301_3.9	V1 P80	V 1 C V 1 F	P80	BN80C2	124-125
526	100	22	60	3.1	1.4	1.9	2340	S401_1.9	V2 P90	V 2 C V 2 F	P90	BN90LA4	126-127
645	123	18.2	49	2.2	1.4	3.1	1290	S301_3.1	V1 P80	V 1 C V 1 F	P80	BN80C2	124-125
714	136	16.5	44	2.1	1.0	1.4	1240	S301_1.4	— P90	— V 2 F	P90	BN90LA4	124-125
714	136	16.5	44	4.3	1.9	1.4	2130	S401_1.4	V2 P90	V 2 C V 2 F	P90	BN90LA4	126-127



## 1.5 kW

$n_2$ min <sup>-1</sup>	$n_2'$ min <sup>-1</sup>	$M_2$ Nm	$M_2'$ Nm	S	S'	i	R <sub>n2</sub> N					IEC 	
833	158	14.1	38	2.8	1.9	2.4	1210	S301_2.4	V1 P80	V 1 C V 1 F	P80	BN80C2	124-125
1111	211	10.6	28	2.3	1.5	1.8	1110	S301_1.8	V1 P80	V 1 C V 1 F	P80	BN80C2	124-125
1429	271	8.2	22	2.9	1.9	1.4	1030	S301_1.4	V1 P80	V 1 C V 1 F	P80	BN80C2	124-125

## 1.85 kW

135	25.7	102	254	1.4	0.6	7.4	4890	S501_7.4	V2 P90	V 2 C V 2 F	P90	BN90LB4	128-129
164	31	84	209	1.3	0.5	6.1	3220	S401_6.1	V2 P90	V 2 C V 2 F	P90	BN90LB4	126-127
164	31	84	209	1.8	0.7	6.1	4630	S501_6.1	V2 P90	V 2 C V 2 F	P90	BN90LB4	128-129
208	40	66	165	1.6	0.8	4.8	3030	S401_4.8	V2 P90	V 2 C V 2 F	P90	BN90LB4	126-127
208	40	66	165	2.7	1.1	4.8	4310	S501_4.8	V2 P90	V 2 C V 2 F	P90	BN90LB4	128-129
263	50	52	130	2.0	1.0	3.8	2850	S401_3.8	V2 P90	V 2 C V 2 F	P90	BN90LB4	126-127
263	50	52	130	3.4	1.5	3.8	4050	S501_3.8	V2 P90	V 2 C V 2 F	P90	BN90LB4	128-129
323	61	43	106	2.5	1.2	3.1	2680	S401_3.1	V2 P90	V 2 C V 2 F	P90	BN90LB4	126-127
333	63	41	103	3.9	1.9	3.0	3780	S501_3	V2 P90	V 2 C V 2 F	P90	BN90LB4	128-129
417	79	33	82	3.2	1.5	2.4	2500	S401_2.4	V2 P90	V 2 C V 2 F	P90	BN90LB4	126-127
526	100	26	65	2.7	1.3	1.9	2320	S401_1.9	V2 P90	V 2 C V 2 F	P90	BN90LB4	126-127
714	136	19.2	48	1.8	0.9	1.4	1220	S301_1.4	— P90	— V 2 F	P90	BN90LB4	124-125
714	136	19.2	48	3.6	1.8	1.4	2110	S401_1.4	V2 P90	V 2 C V 2 F	P90	BN90LB4	126-127

## 2.2 kW

109	20.5	143	335	1.0	0.4	6.1	5090	S501_6.1	V3 P100	V 3 C V 3 F	P112	BN112M6	128-129
135	25.7	116	290	1.2	0.5	7.4	4820	S501_7.4	V3 P100	V 3 C V 3 F	P100	BN100LA4	128-129
164	31	96	239	1.6	0.6	6.1	4570	S501_6.1	V3 P100	V 3 C V 3 F	P100	BN100LA4	128-129
174	33	89	209	2.0	1.0	3.8	4500	S501_3.8	V3 P100	V 3 C V 3 F	P112	BN112M6	128-129
208	40	75	188	1.4	0.7	4.8	2975	S401_4.8	— P100	— V 3 F	P100	BN100LA4	126-127
208	40	75	188	2.3	1.0	4.8	4270	S501_4.8	V3 P100	V 3 C V 3 F	P100	BN100LA4	128-129
221	42	71	165	2.3	1.2	3.0	4220	S501_3	V3 P100	V 3 C V 3 F	P112	BN112M6	128-129
263	50	60	149	2.9	1.3	3.8	4010	S501_3.8	V3 P100	V 3 C V 3 F	P100	BN100LA4	128-129
323	61	49	122	2.2	1.0	3.1	2640	S401_3.1	— P100	— V 3 F	P100	BN100LA4	126-127
333	63	47	118	3.4	1.7	3.0	3750	S501_3	V3 P100	V 3 C V 3 F	P100	BN100LA4	128-129

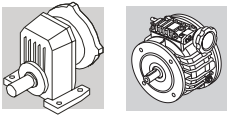

## 2.2 kW

$n_2$ min <sup>-1</sup>	$n_2'$ min <sup>-1</sup>	$M_2$ Nm	$M_2'$ Nm	S	S'	i	R <sub>n2</sub> N					IEC	
368	69	42	99	3.0	1.6	1.8	3600	S501_1.8	V3 P100	V 3 C V 3 F	P112	BN112M6	128-129
417	79	38	94	4.0	1.9	2.4	3490	S501_2.4	V3 P100	V 3 C V 3 F	P100	BN100LA4	128-129
474	89	33	77	3.8	2.0	1.4	3360	S501_1.4	V3 P100	V 3 C V 3 F	P112	BN112M6	128-129
526	100	30	74	2.3	1.1	1.9	2290	S401_1.9	— P100	— V 3 F	P100	BN100LA4	126-127
556	106	28	71	4.4	2.2	1.8	3190	S501_1.8	V3 P100	V 3 C V 3 F	P100	BN100LA4	128-129
714	136	22	55	1.6	0.8	1.4	1190	S301_1.4	— P100	— V 3 F	P100	BN100LA4	124-125
714	136	22	55	3.2	1.5	1.4	2090	S401_1.4	— P100	— V 3 F	P100	BN100LA4	126-127
714	136	22	55	5.7	2.8	1.4	2970	S501_1.4	V3 P100	V 3 C V 3 F	P100	BN100LA4	128-129

## 3 kW

164	31	143	335	1.0	0.4	6.1	4360	S501_6.1	V3 P100	V 3 C V 3 F	P100	BN100LB4	128-129
208	40	113	263	1.6	0.7	4.8	4090	S501_4.8	V3 P100	V 3 C V 3 F	P100	BN100LB4	128-129
263	50	89	209	2.0	1.0	3.8	3870	S501_3.8	V3 P100	V 3 C V 3 F	P100	BN100LB4	128-129
323	61	73	170	1.4	0.7	3.1	2500	S401_3.1	— P100	— V 3 F	P100	BN100LB4	126-127
333	63	71	165	2.3	1.2	3.0	3640	S501_3	V3 P100	V 3 C V 3 F	P100	BN100LB4	128-129
417	79	56	132	2.7	1.4	2.4	3400	S501_2.4	V3 P100	V 3 C V 3 F	P100	BN100LB4	128-129
526	100	45	104	1.6	0.8	1.9	2200	S401_1.9	— P100	— V 3 F	P100	BN100LB4	126-127
556	106	42	99	3.0	1.6	1.8	3110	S501_1.8	V3 P100	V 3 C V 3 F	P100	BN100LB4	128-129
714	136	33	77	2.1	1.1	1.4	2100	S401_1.4	— P100	— V 3 F	P100	BN100LB4	126-127
714	136	33	77	3.8	2.0	1.4	2900	S501_1.4	V3 P100	V 3 C V 3 F	P100	BN100LB4	128-129





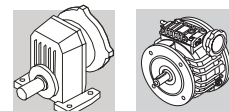

## 4 kW

164	31	191	430	0.8	0.3	6.1	4160	S501_6.1	V55 P112	V 5.5 C V 5.5 F	P112	BN112M4	128-129
208	40	151	339	1.2	0.5	4.8	3910	S501_4.8	V55 P112	V 5.5 C V 5.5 F	P112	BN112M4	128-129
263	50	119	268	1.5	0.7	3.8	3720	S501_3.8	V55 P112	V 5.5 C V 5.5 F	P112	BN112M4	128-129
276	52	148	273	1.0	0.7	2.4	3710	S501_2.4	— P132	— V 10 F	P132	BN132MA6	128-129
333	63	94	212	1.7	0.9	3.0	3520	S501_3	V55 P112	V 5.5 C V 5.5 F	P112	BN112M4	128-129
368	69	111	205	1.1	0.8	1.8	3430	S501_1.8	— P132	— V 10 F	P132	BN132MA6	128-129
417	79	75	169	2.0	1.1	2.4	3300	S501_2.4	V55 P112	V 5.5 C V 5.5 F	P112	BN112M4	128-129
474	89	86	159	1.4	1.0	1.4	3210	S501_1.4	— P132	— V 10 F	P132	BN132MA6	128-129





## 4 kW

$n_2$ min <sup>-1</sup>	$n_2'$ min <sup>-1</sup>	M <sub>2</sub> Nm	M <sub>2'</sub> Nm	S	S'	i	R <sub>n2</sub> N					IEC 	
556	106	56	127	2.2	1.2	1.8	3040	S501_1.8	V55 P112	V 5.5 C V 5.5 F	P112	BN112M4	128-129
714	136	44	99	1.6	0.9	1.4	1950	S401_1.4	— P112	— V 5.5 F	P112	BN112M4	126-127
714	136	44	99	2.8	1.6	1.4	2840	S501_1.4	V55 P112	V 5.5 C V 5.5 F	P112	BN112M4	128-129

## 5.5 kW

263	50	160	320	1.1	0.6	3.8	3520	S501_3.8	— P132	— V 10 F	P132	BN132S4	128-129
333	63	126	253	1.3	0.8	3.0	3360	S501_3	— P132	— V 10 F	P132	BN132S4	128-129
417	79	101	202	1.5	0.9	2.4	3170	S501_2.4	— P132	— V 10 F	P132	BN132S4	128-129
474	89	86	159	1.4	1.0	1.4	3060	S501_1.4	— P132	— V 10 F	P132	BN132MB6	128-129
556	106	76	152	1.6	1.0	1.8	2940	S501_1.8	— P132	— V 10 F	P132	BN132S4	128-129
714	136	59	118	1.2	0.7	1.4	1850	S401_1.4	— P132	— V 10 F	P132	BN132S4	126-127
714	136	59	118	2.1	1.3	1.4	2760	S501_1.4	— P132	— V 10 F	P132	BN132S4	128-129

## 7.5 kW

417	79	136	273	1.1	0.7	2.4	2990	S501_2.4	— P132	— V 10 F	P132	BN132MA4	128-129
556	106	102	205	1.2	0.8	1.8	2800	S501_1.8	— P132	— V 10 F	P132	BN132MA4	128-129
714	136	80	159	1.6	1.0	1.4	2640	S501_1.4	— P132	— V 10 F	P132	BN132MA4	128-129

## 9.2 kW

556	106	127	254	1.0	0.6	1.8	2660	S501_1.8	— P132	— V 10 F	P132	BN132MB4	128-129
714	136	99	198	1.3	0.8	1.4	2530	S501_1.4	— P132	— V 10 F	P132	BN132MB4	128-129

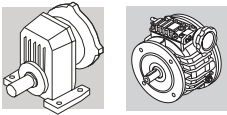

# S 10

## 21.10 - Dimensioni serie S+V

## 21.10 - Dimensions series S+V

## 21.10 - Abmessungen - serie S+V

## 21.10 - Dimensions series S+V

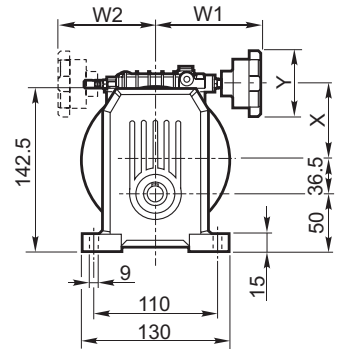
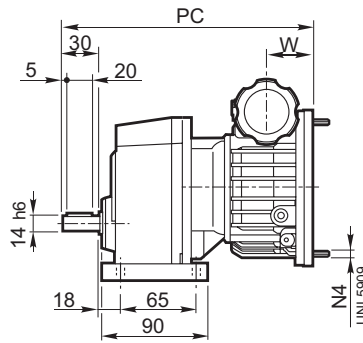
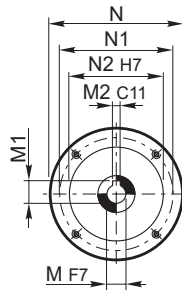

## S 101 P + V\_P (IEC)

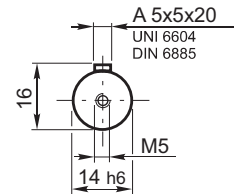
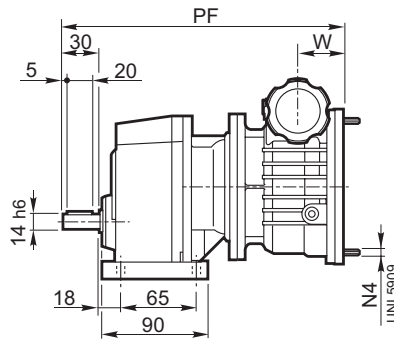

	IEC	V_C - V_F												S 101P + V_C		S 101P + V_F		
		N	N1	N2	N4	M	M1	M2	W	W1	W2	X	Y	PC	Kg	PF	Kg	
S 101P	V 0.25	P63	140	115	95	M8x20	11	12.8	4	45	115	110	70	83	216	7.1	298	9.5
	V 0.5	P71	160	130	110	M8x20	14	16.3	5	47.5	115	110	78	83	218	10.2	300	12.6
	V 0.5	P80	200	165	130	M10x20	19	20.8*	6	51.5	115	110	78	83	222	10.2	304	12.6

\* Utilizzare linguetta ribassata di ns. fornitura 6x5x30 "A"

\* Use thin parallel key 6x5x30 "A" supplied by Bonfiglioli

\* Den bei uns verfügbaren flachen Federkeil "A" 6x5x30 verwenden

\* Utiliser une languette abaissée de notre fabrication 6x5x30 "A"

## S 101 P + V\_P + BN

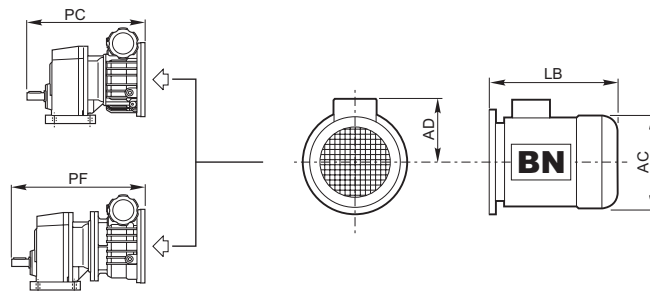

	IEC	BN			S 101P + V_C		S 101P + V_F		
		AC	AD	LB	PC+LB	Kg	PF+LB	Kg	
S 101P	V 0.25	63	121	95	184	400	11.0	481.5	13.4
	V 0.25	71R	138	108	219	435	12.5	516.5	14.9
	V 0.5	71	138	108	219	437	16.1	519	18.5
	V 0.5	80	156	119	234	456	20.1	538	22.5

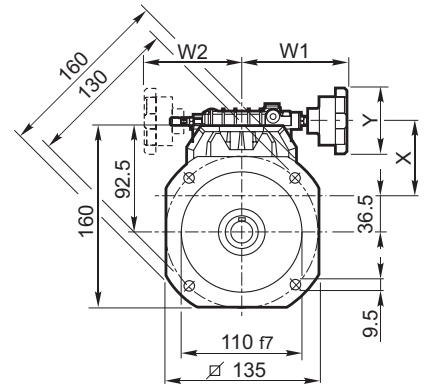
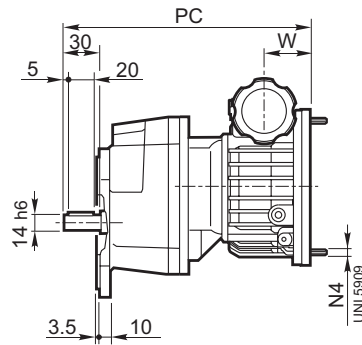
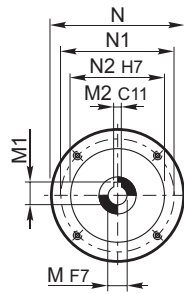
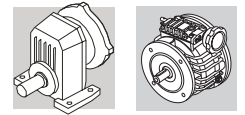

## S 101 F\_ + V\_P (IEC)

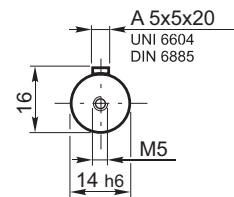
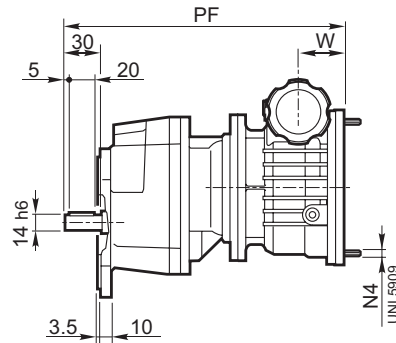

	IEC	V_C - V_F												S 101F + V_C		S 101F + V_F		
		N	N1	N2	N4	M	M1	M2	W	W1	W2	X	Y	PC		PF		
S 101F	V 0.25	P63	140	115	95	M8x20	11	12.8	4	45	115	110	70	83	216	7.2	298	9.6
	V 0.5	P71	160	130	110	M8x20	14	16.3	5	47.5	115	110	78	83	218	10.3	300	12.7
	V 0.5	P80	200	165	130	M10x20	19	20.8*	6	51.5	115	110	78	83	222	10.3	304	12.7

\* Utilizzare linguetta ribassata di ns. fornitura 6x5x30 "A"

\* Use thin parallel key 6x5x30 "A" supplied by Bonfiglioli

\* Den bei uns verfügbaren flachen Federkeil "A" 6x5x30 verwenden

\* Utiliser une languette abaissée de notre fabrication 6x5x30 "A"

## S 101 F + V\_P + BN

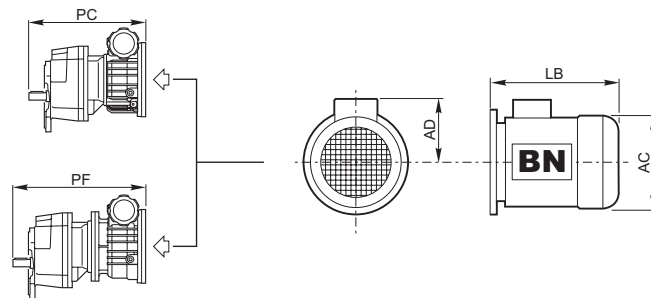

	IEC	BN			S 101F + V_C		S 101F + V_F		
		AC	AD	LB	PC+LB		PF+LB		
S 101F	V 0.25	63	121	95	184	400	11.1	482	13.5
	V 0.25	71R	138	108	219	435	12.6	517	15.0
	V 0.5	71	138	108	219	437	16.2	519	18.6
	V 0.5	80	156	119	234	456	20.2	538	22.6

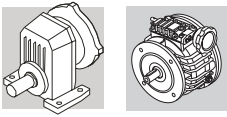

# S 20

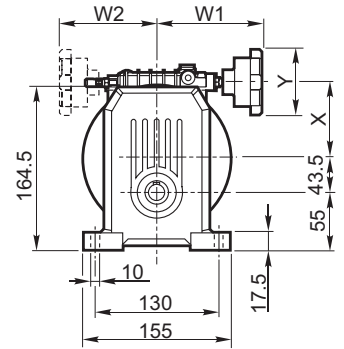
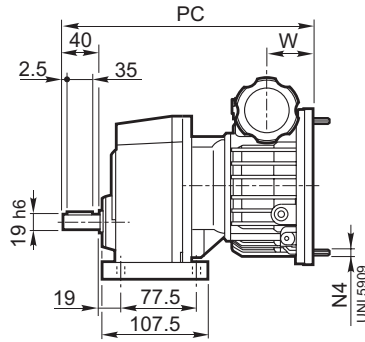
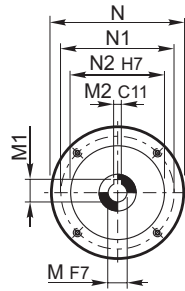

## S 201 P\_ + V\_P (IEC)

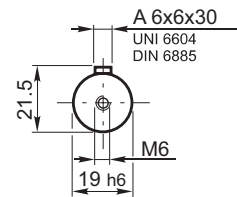
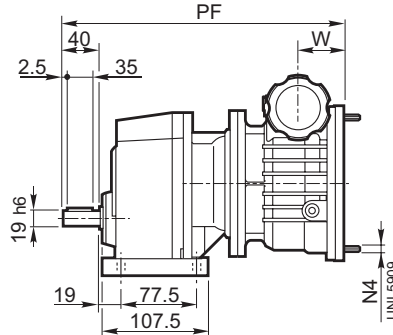

	IEC	V_C - V_F												S 201P+ V_C		S 201P+ V_F		
		N	N1	N2	N4	M	M1	M2	W	W1	W2	X	Y	PC	Kg	PF	Kg	
S 201P	V 0.25	P63	140	115	95	M8x20	11	12.8	4	45	115	110	70	83	241	8.3	316	10.5
	V 0.5	P71	160	130	110	M8x20	14	16.3	5	47.5	115	110	78	83	244	10.9	318	13.7
	V 0.5	P80	200	165	130	M10x20	19	20.8*	6	51.5	115	110	78	83	248	10.9	322	13.7
	V 1	P80	200	165	130	M10x20	19	21.8	6	59	133	124	97	83	—	—	364	21.1
	V 1	P90	200	165	130	M10x20	24	26.3**	8	59	133	124	97	83	—	—	364	21.1

\* Utilizzare linguetta ribassata di ns. fornitura 6x5x30 "A"

\* Use thin parallel key 6x5x30 "A" supplied by Bonfiglioli

\* Den bei uns verfügbaren flachen Federkeil "A" 6x5x30 verwenden

\* Utiliser une languette abaissée de notre fabrication 6x5x30 "A"

\*\* Utilizzare linguetta ribassata di ns. fornitura 8x6x35 "A"

\*\* Use thin parallel key 8x6x35 "A" supplied by Bonfiglioli

\*\* Den bei uns verfügbaren flachen Federkeil "A" 8x6x35 verwenden

\*\* Utiliser une languette abaissée de notre fabrication 8x6x35 "A"

## S 201 P + V\_P + BN

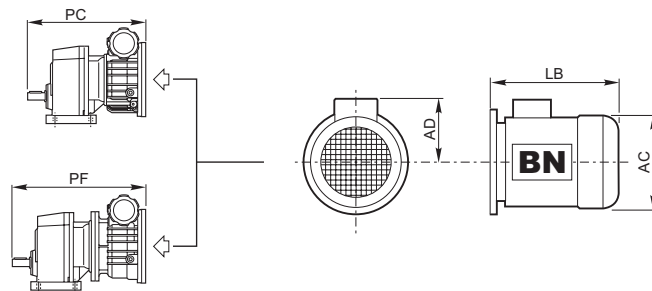

	IEC	BN			S 201P + V_C		S 201P + V_F		
		AC	AD	LB	PC+LB	Kg	PF+LB	Kg	
S 201P	V 0.25	63	121	95	184	425	12.2	500	14.4
	V 0.25	71R	138	108	219	460	13.7	535	15.9
	V 0.5	71	138	108	219	463	16.8	537	19.6
	V 0.5	80	156	119	234	482	20.8	556	23.6
	V 1	80	156	119	234	—	—	598	31
	V 1	90S	176	133	276	—	—	640	33.4
	V 1	90L	176	133	276	—	—	640	35.4

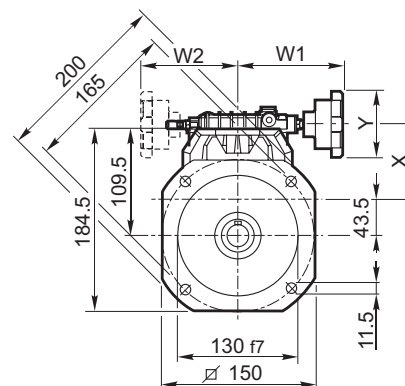
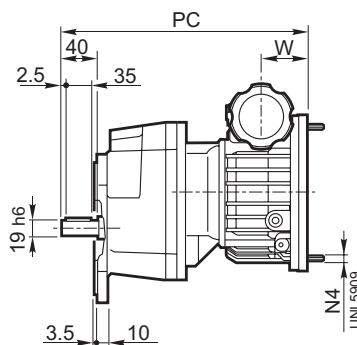
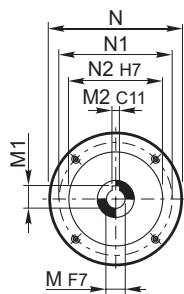
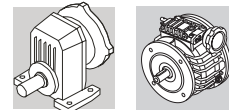

## S 201 F\_ + V\_P (IEC)

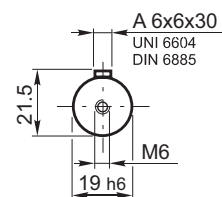
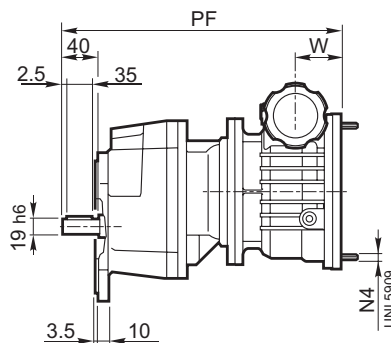

	IEC	V_C - V_F												S 201F+ V_C		S 201F + V_F		
		N	N1	N2	N4	M	M1	M2	W	W1	W2	X	Y	PC	Kg	PF	Kg	
S 201F	V 0.25	P63	140	115	95	M8X20	11	12.8	4	45	115	110	70	83	241	8.5	316	10.7
	V 0.5	P71	160	130	110	M8X20	14	16.3	5	47.5	115	110	78	83	244	11	318	13.8
	V 0.5	P80	200	165	130	M10X20	19	20.8*	6	51.5	115	110	78	83	248	11	322	13.8
	V 1	P80	200	165	130	M10X20	19	21.8	6	59	133	124	97	83	—	—	364	21.3
	V 1	P90	200	165	130	M10X20	24	26.3**	8	59	133	124	97	83	—	—	364	21.3

\* Utilizzare linguetta ribassata di ns. fornitura 6x5x30 "A"

\* Use thin parallel key 6x5x30 "A" supplied by Bonfiglioli

\* Den bei uns verfügbaren flachen Federkeil "A" 6x5x30 verwenden

\* Utiliser une languette abaissée de notre fabrication 6x5x30 "A"

\*\* Utilizzare linguetta ribassata di ns. fornitura 8x6x35 "A"

\*\* Use thin parallel key 8x6x35 "A" supplied by Bonfiglioli

\*\* Den bei uns verfügbaren flachen Federkeil "A" 8x6x35 verwenden

\*\* Utiliser une languette abaissée de notre fabrication 8x6x35 "A"

## S 201 F + V\_P + BN

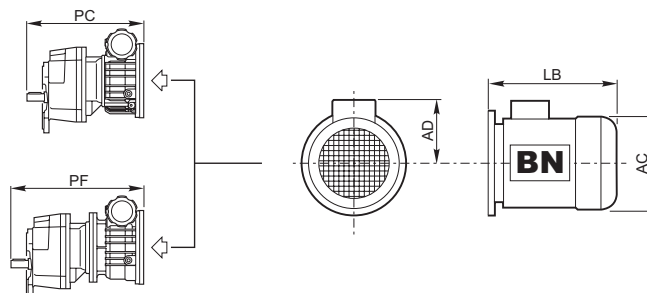

	IEC	BN			S 201F + V_C		S 201F + V_F	
		AC	AD	LB	PC+LB	Kg	PF+LB	Kg
S 201F	V 0.25	63	121	95	425	12.4	500	14.6
	V 0.25	71R	138	108	460	13.9	535	16.1
	V 0.5	71	138	108	463	16.9	537	19.7
	V 0.5	80	156	119	482	20.9	556	23.7
	V 1	80	156	119	—	—	598	31
	V 1	90S	176	133	—	—	640	34
	V 1	90L	176	133	—	—	640	36

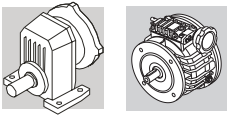

# S 30

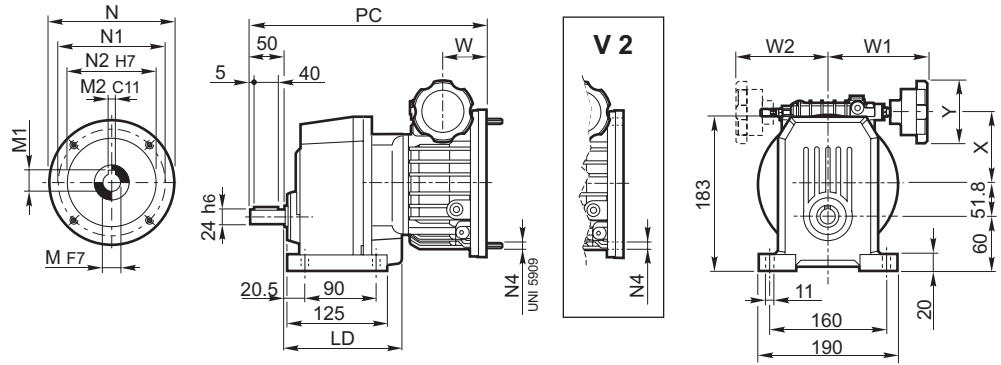

## S 301 P + V\_P (IEC)

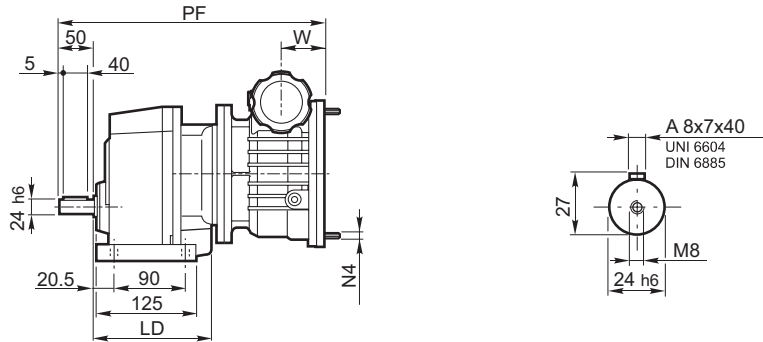

	IEC	V_C - V_F														S 301P+ V_C		S 301P+ V_F	
		LD	N	N1	N2	N4	M	M1	M2	W	W1	W2	X	Y	PC		PF		
S 301P	V 0.25	P 63	152.5	140	115	95	M8X20	11	12.8	4	45	115	110	70	83	—	—	341	12.4
	V 0.5	P 71	152.5	160	130	110	M8X20	14	16.3	5	47.5	115	110	78	83	269	13.1	343	15.6
	V 0.5	P 80	162.5	200	165	130	M10X20	19	20.8*	6	51.5	115	110	78	83	273	13.1	347	15.6
	V 1	P 80	162.5	200	165	130	M10X20	19	21.8	6	59	133	124	97	83	305	19.1	389	23.1
	V 1	P 90	162.5	200	165	130	M10X20	24	26.3**	8	59	133	124	97	83	305	19.1	389	23.1
	V 2	P 90	162.5	200	165	130	M10X15	24	27.3	8	74.1	137	120	113	83	—	—	413	27.8

\* Utilizzare linguetta ribassata di ns. fornitura 6x5x30 "A"

\* Use thin parallel key 6x5x30 "A" supplied by Bonfiglioli

\* Den bei uns verfügbaren flachen Federkeil "A" 6x5x30 verwenden

\* Utiliser une languette abaissée de notre fabrication 6x5x30 "A"

\*\* Utilizzare linguetta ribassata di ns. fornitura 8x6x35 "A"

\*\* Use thin parallel key 8x6x35 "A" supplied by Bonfiglioli

\*\* Den bei uns verfügbaren flachen Federkeil "A" 8x6x35 verwenden

\*\* Utiliser une languette abaissée de notre fabrication 8x6x35 "A"

## S 301 P + V\_P + BN

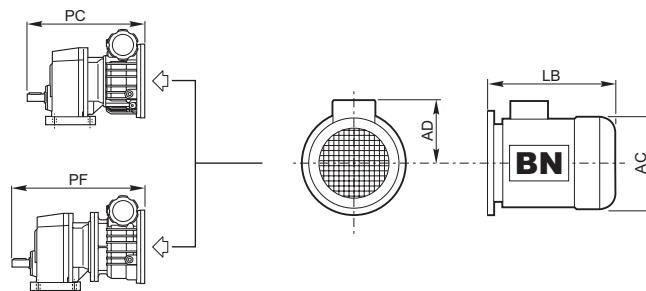

	IEC	BN			S 301P + V_C		S 301P + V_F		
		AC	AD	LB	PC+LB		PF+LB		
S 301P	V 0.25	63	121	95	184	—	—	525	16.3
	V 0.25	71R	138	108	219	—	—	560	17.8
	V 0.5	71	138	108	219	488	19.0	562	21.5
	V 0.5	80	156	119	234	507	23.0	581	25.5
	V 1	80	156	119	234	539	29.0	623	33
	V 1	90S	176	133	276	581	31	665	35
	V 1	90L	176	133	276	581	33	665	37
	V 2	90S	176	133	276	—	—	689	40
	V 2	90L	176	133	276	—	—	689	42
	V 2	100R	195	142	307	—	—	720	50

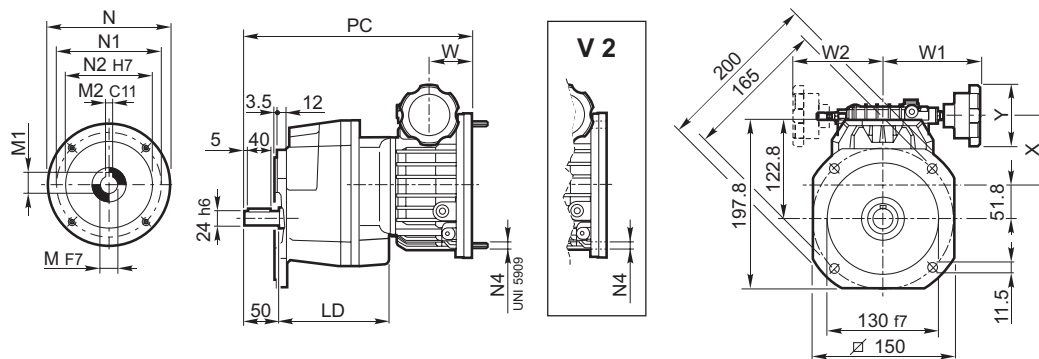
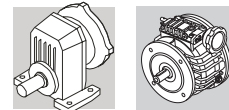

## S 301 F + V\_P (IEC)

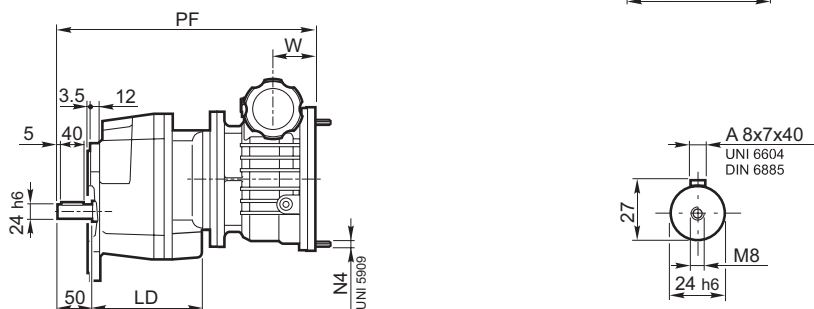

	IEC	V_C - V_F													S 301F+ V_C		S 301F+ V_F		
		LD	N	N1	N2	N4	M	M1	M2	W	W1	W2	X	Y	PC		PF		
S 301F	V 0.25	P63	152.5	140	115	95	M8X20	11	12.8	4	45	115	110	70	83	—	—	341	12.7
	V 0.5	P71	152.5	160	130	110	M8X20	14	16.3	5	47.5	115	110	78	83	269	13.4	343	15.9
	V 0.5	P80	162.5	200	165	130	M10X20	19	20.8*	6	51.5	115	110	78	83	273	13.4	347	15.9
	V 1	P80	162.5	200	165	130	M10X20	19	21.8	6	59	133	124	97	83	305	19.4	389	23.4
	V 1	P90	162.5	200	165	130	M10X20	24	26.3**	8	59	133	124	97	83	305	19.4	389	23.4
	V 2	P90	162.5	200	165	130	M10X15	24	27.3	8	74.1	137	120	113	83	—	—	413	28.1

\* Utilizzare linguetta ribassata di ns. fornitura 6x5x30 "A"

\* Use thin parallel key 6x5x30 "A" supplied by Bonfiglioli

\* Den bei uns verfügbaren flachen Federkeil "A" 6x5x30 verwenden

\* Utiliser une languette abaissée de notre fabrication 6x5x30 "A"

\*\* Utilizzare linguetta ribassata di ns. fornitura 8x6x35 "A"

\*\* Use thin parallel key 8x6x35 "A" supplied by Bonfiglioli

\*\* Den bei uns verfügbaren flachen Federkeil "A" 8x6x35 verwenden

\*\* Utiliser une languette abaissée de notre fabrication 8x6x35 "A"

## S 301 F + V\_P + BN

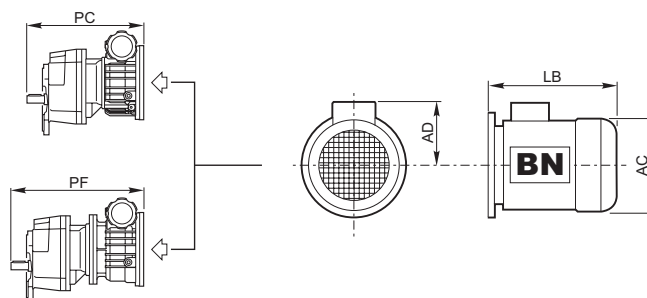

	IEC	BN			S 301F+ V_C		S 301F+ V_F		
		AC	AD	LB	PC+LB		PF+LB		
S 301F	V 0.25	63	121	95	184	—	—	525	16.6
	V 0.25	71R	138	108	219	—	—	560	18.1
	V 0.5	71	138	108	219	488	19.3	562	21.8
	V 0.5	80	156	119	234	507	23.3	581	25.8
	V 1	80	156	119	234	539	29.3	523	33
	V 1	90S	176	133	276	581	32	665	36
	V 1	90L	176	133	276	581	34	665	38
	V 2	90S	176	133	276	—	—	689	40
	V 2	90L	176	133	276	—	—	689	42
	V 2	100R	195	142	307	—	—	720	50

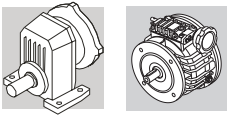

# S 40

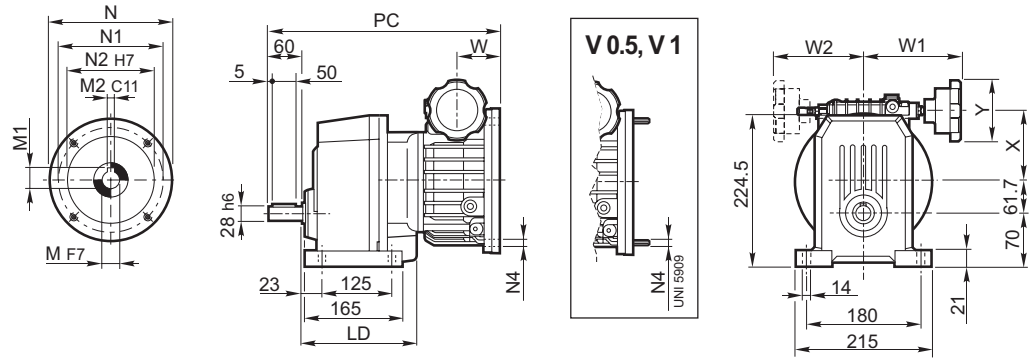

## S 401 P + V\_P (IEC)

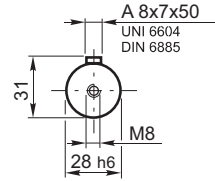
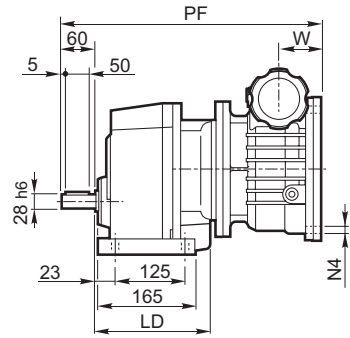

	IEC	V_C - V_F													S 401P+ V_C		S 401P+ V_F		
		LD	N	N1	N2	N4	M	M1	M2	W	W1	W2	X	Y	PC	Kg	PF	Kg	
S 401P	V 0.5	P71	183.5	160	130	110	M8X20	14	16.3	5	47.5	115	110	78	83	318	25.6	385	30
	V 0.5	P80	199.5	200	165	130	M10X20	19	20.8*	6	51.5	115	110	78	83	322	25.6	389	30
	V 1	P80	199.5	200	165	130	M10X20	19	21.8	6	59	133	124	97	83	347	32	431	38
	V 1	P90	199.5	200	165	130	M10X20	24	26.3**	8	59	133	124	97	83	347	32	431	38
	V 2	P90	199.5	200	165	130	M10X15	24	27.3	8	74.1	137	120	113	83	370	37	455	43
	V 3	P100	—	250	215	180	M12x23	28	31.3	8	91	172.5	—	150.5	109	—	—	519	67
V 5.5	P112	—	250	215	180	M12x23	28	31.3	8	108	172.5	—	150.5	109	—	—	519	67	

\* Utilizzare linguetta ribassata di ns. fornitura 6x5x30 "A"

\* Use thin parallel key 6x5x30 "A" supplied by Bonfiglioli

\* Den bei uns verfügbaren flachen Federkeil "A" 6x5x30 verwenden

\* Utiliser une languette abaissée de notre fabrication 6x5x30 "A"

\*\* Utilizzare linguetta ribassata di ns. fornitura 8x6x35 "A"

\*\* Use thin parallel key 8x6x35 "A" supplied by Bonfiglioli

\*\* Den bei uns verfügbaren flachen Federkeil "A" 8x6x35 verwenden

\*\* Utiliser une languette abaissée de notre fabrication 8x6x35 "A"

## S 401 P + V\_P + BN

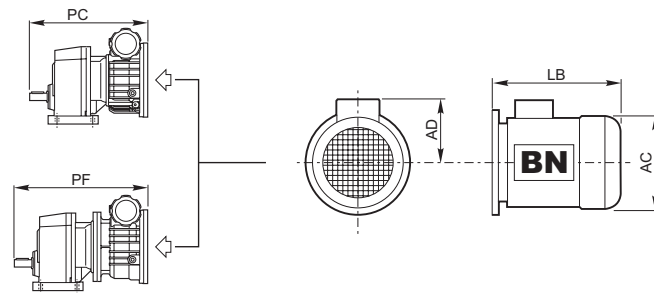

	IEC	BN			S 401P + V_C		S 401P + V_F		
		AC	AD	LB	PC+LB	Kg	PF+LB	Kg	
S 401P	V 0.5	71	138	108	219	537	32	604	36
	V 0.5	80	156	119	234	556	36	623	40
	V 1	80	156	119	234	581	42	665	48
	V 1	90S	176	133	276	623	44	707	51
	V 1	90L	176	133	276	623	46	707	53
	V 2	90S	176	133	276	646	49	731	55
	V 2	90L	176	133	276	646	51	731	57
	V 2	100R	195	142	307	677	59	762	65
	V 3	100	195	142	307	—	—	826	89
	V 3	112	219	157	325	—	—	844	97
	V 5.5	112	219	157	325	—	—	844	97



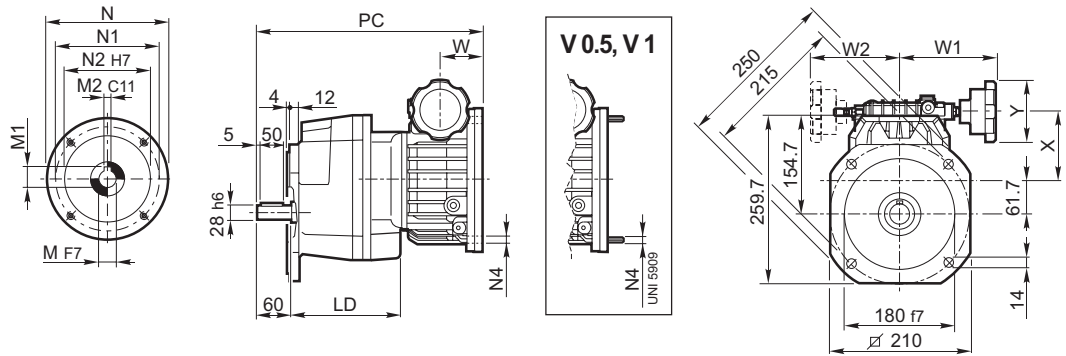
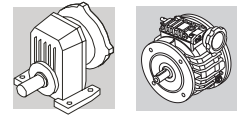

## S 401 F + V\_P (IEC)

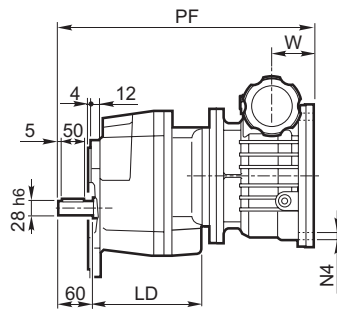

	IEC	V_C - V_F														S 401F+ V_C		S 401F+ V_F	
		LD	N	N1	N2	N4	M	M1	M2	W	W1	W2	X	Y	PC		PF		
S 401F	V 0.5	P71	183.5	160	130	110	M8X20	14	16.3	5	47.5	115	110	78	83	318	27.4	385	32
	V 0.5	P80	199.5	200	165	130	M10X20	19	20.8*	6	51.5	115	110	78	83	322	27.4	389	32
	V 1	P80	199.5	200	165	130	M10X20	19	21.8	6	59	133	124	97	83	347	34	431	40
	V 1	P90	199.5	200	165	130	M10X20	24	26.3**	8	59	133	124	97	83	347	34	431	40
	V 2	P90	199.5	200	165	130	M10X15	24	27.3	8	74.1	137	120	113	83	370	38	455	45
	V 3	P100	—	250	215	180	M12x23	28	31.3	8	—	172.5	—	150.5	109	—	—	519	69
V 5.5	P112	—	250	215	180	M12x23	28	31.3	8	—	172	—	150.5	109	—	—	519	69	

\* Utilizzare linguetta ribassata di ns. fornitura 6x5x30 "A"

\* Use thin parallel key 6x5x30 "A" supplied by Bonfiglioli

\* Den bei uns verfügbaren flachen Federkeil "A" 6x5x30 verwenden

\* Utiliser une languette abaissée de notre fabrication 6x5x30 "A"

\*\* Utilizzare linguetta ribassata di ns. fornitura 8x6x35 "A"

\*\* Use thin parallel key 8x6x35 "A" supplied by Bonfiglioli

\*\* Den bei uns verfügbaren flachen Federkeil "A" 8x6x35 verwenden

\*\* Utiliser une languette abaissée de notre fabrication 8x6x35 "A"

## S 401 F + V\_P + BN

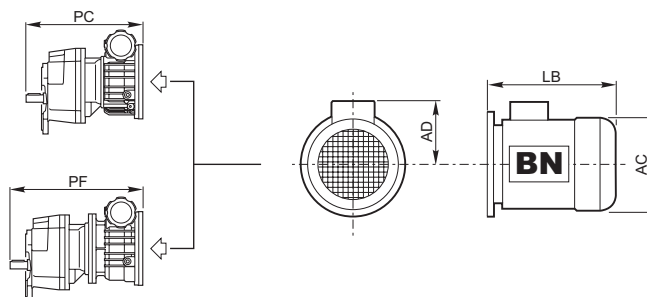

	IEC	BN			S 401F + V_C		S 401F + V_F		
		AC	AD	LB	PC+LB		PF+LB		
S 401F	V 0.5	71	138	108	219	537	33	604	38
	V 0.5	80	156	119	234	556	37	623	42
	V 1	80	156	119	234	581	44	665	50
	V 1	90S	176	133	276	623	46	707	52
	V 1	90L	176	133	276	623	48	707	54
	V 2	90S	176	133	276	646	51	731	57
	V 2	90L	176	133	276	646	53	731	59
	V 2	100R	195	142	307	677	61	762	67
	V 3	100	195	142	307	—	—	826	91
	V 3	112	219	157	325	—	—	844	99
	V 5.5	112	219	157	325	—	—	844	99

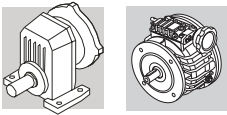

# S 50

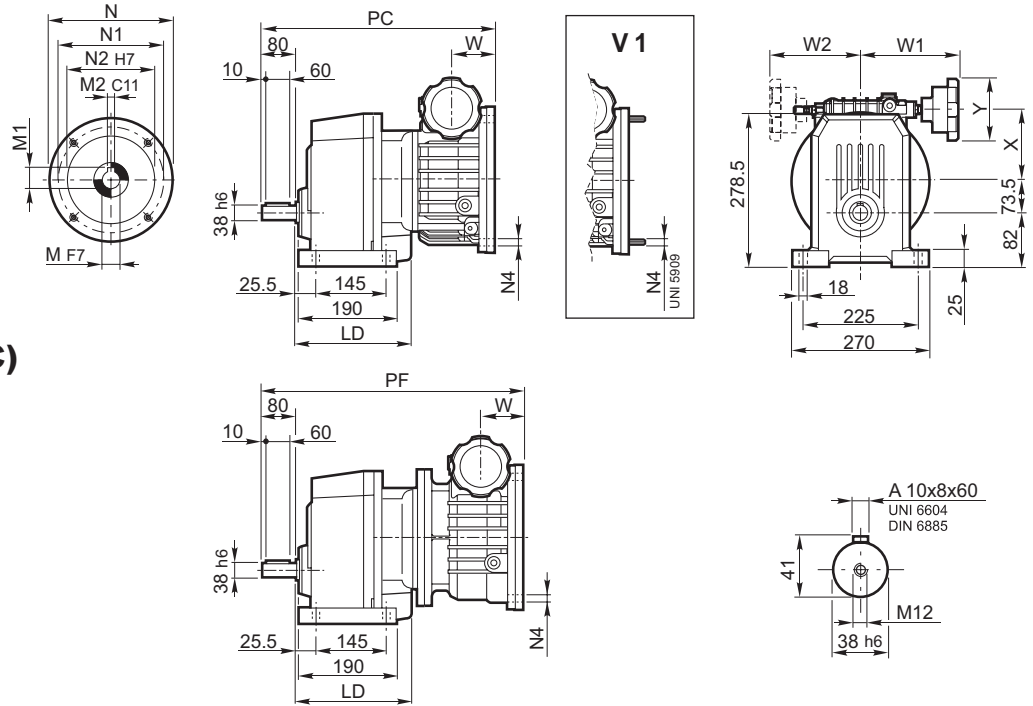

## S 501 P + V\_P (IEC)

	IEC	V_C - V_F														S 501P+ V_C		S 501P+ V_F	
		LD	N	N1	N2	N4	M	M1	M2	W	W1	W2	X	Y	PC		PF		
S 501P	V 1	P80	219.5	200	165	130	M10X20	19	21.8	6	59	133	124	97	83	—	—	451	49
	V 1	P90	219.5	200	165	130	M10X20	24	26.3*	8	59	133	124	97	83	—	—	451	49
	V 2	P90	219.5	200	165	130	M10X15	24	27.3	8	74.1	137	120	113	83	410	46	495	54
	V 3	P100	204.5	250	215	180	M12x23	28	31.3	8	91	172.5	—	150.5	109	452	66	559	78
	V 5.5	P112	204.5	250	215	180	M12x23	28	31.3	8	91	172.5	—	150.5	109	452	67	559	80
	V 10	P132	204.5	300	265	230	M12x25	38	41.3	10	108	193.5	—	206.5	109	—	—	636	138

\* Utilizzare linguetta ribassata di ns. fornitura 8x6x35 "A"

\* Use thin parallel key 8x6x35 "A" supplied by Bonfiglioli

\* Den bei uns verfügbaren flachen Federkeil "A" 8x6x35 verwenden

\* Utiliser une languette abaissée de notre fabrication 8x6x35 "A"

## S 501 P + V\_P + BN

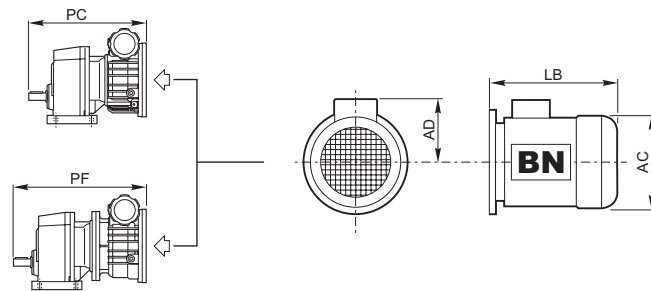

	IEC	BN			S 501P + V_C		S 501P + V_F		
		AC	AD	LB	PC+LB		PF+LB		
S 501P	V 1	80	156	119	234	—	—	685	59
	V 1	90S	176	133	276	—	—	727	61
	V 1	90L	176	133	276	—	—	727	63
	V 2	90S	176	133	276	686	58	771	66
	V 2	90L	176	133	276	686	60	771	68
	V 2	100R	195	142	307	717	68	802	76
	V 3	100	195	142	307	759	88	866	100
	V 3	112	219	157	325	777	96	884	108
	V 5.5	112	219	157	325	777	97	884	110
	V 10	132S	258	193	375	—	—	1011	181
	V 10	132M	258	193	413	—	—	1049	196

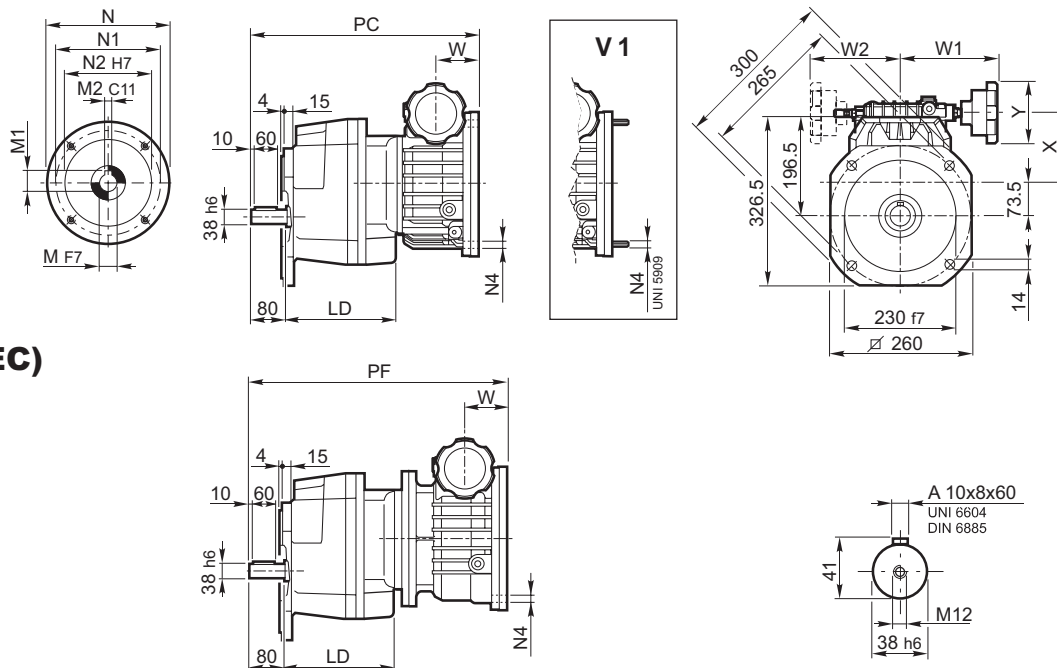
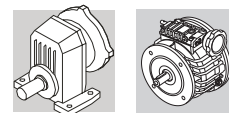

## S 501 F + V\_P (IEC)

	IEC	V_C - V_F														S 501F+ V_C		S 501F+ V_F	
		LD	N	N1	N2	N4	M	M1	M2	W	W1	W2	X	Y	PC		PF		
S 501F	V 1	P80	219.5	200	165	130	M10X20	19	21.8	6	59	133	124	97	83	—	—	451	51
	V 1	P90	219.5	200	165	130	M10X20	24	26.3*	8	59	133	124	97	83	—	—	451	51
	V 2	P90	219.5	200	165	130	M10X15	24	27.3	8	74.1	137	120	113	83	410	48	495	56
	V 3	P100	204.5	250	215	180	M12x23	28	31.3	8	91	172.5	—	150.5	109	451.5	69	559	81
	V 5.5	P112	204.5	250	215	180	M12x23	28	31.3	8	91	172.5	—	150.5	109	451.5	70	559	83
	V 10	P132	204.5	300	265	230	M12x25	38	41.3	10	108	193.5	—	206.5	109	—	—	636	141

\* Utilizzare linguetta ribassata di ns. fornitura 8x6x35 "A"

\* Use thin parallel key 8x6x35 "A" supplied by Bonfiglioli

\* Den bei uns verfügbaren flachen Federkeil "A" 8x6x35 verwenden

\* Utiliser une languette abaissée de notre fabrication 8x6x35 "A"

## S 501 F + V\_P + BN

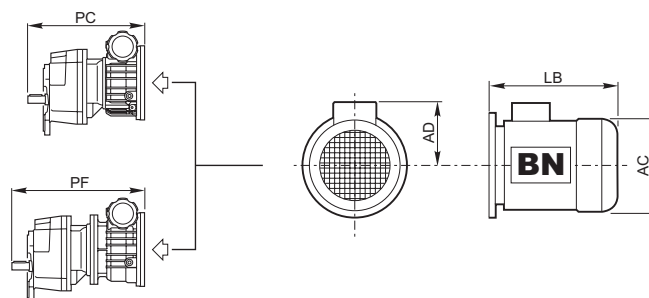

	IEC	BN			S 501F + V_C		S 501F + V_F		
		AC	AD	LB	PC+LB		PF+LB		
S 501F	V 1	80	156	119	234	—	—	685	61
	V 1	90S	176	133	276	—	—	727	63
	V 1	90L	176	133	276	—	—	727	65
	V 2	90S	176	133	276	686	60	771	68
	V 2	90L	176	133	276	686	62	771	70
	V 2	100R	195	142	307	717	70	802	78
	V 3	100	195	142	307	759	91	866	103
	V 3	112	219	157	325	777	99	884	111
	V 5.5	112	219	157	325	777	100	884	113
	V 10	132S	258	193	375	—	—	1011	184
	V 10	132M	258	193	413	—	—	1049	199

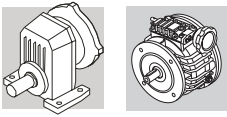

**S\_ + V\_**

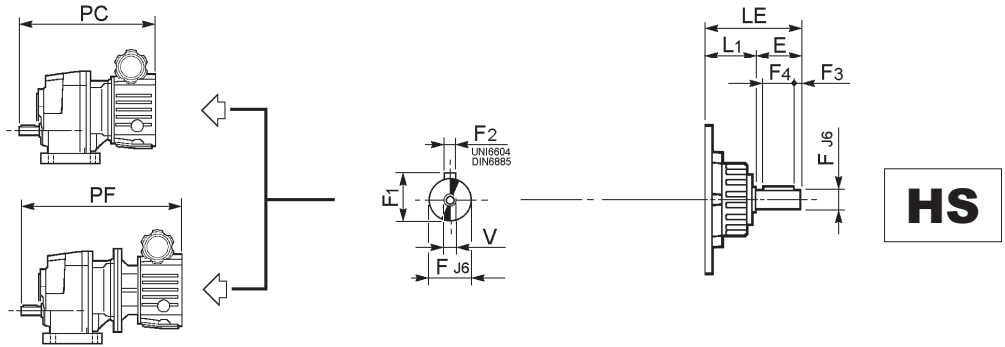

	E	F	F1	F2	F3	F4	LE	L1	V	
<b>V 0.25</b>	23	11	12.5	4	2	20	58.5	35.5	M4	1.1
<b>V 0.5</b>	30	14	16	5	2.5	25	67	37	M5	1.6
<b>V 1</b>	40	19	21.5	6	5	30	88.5	48.5	M6	2.8
<b>V 2</b>	50	24	27	8	5	40	103.5	53.5	M8	4.0
<b>V 3</b>	60	28	31	8	5	50	121.5	61.5	M10	7.0
<b>V 5.5</b>	60	28	31	8	5	50	121.5	61.5	M10	7.0
<b>V 10</b>	80	38	41	10	5	70	160.5	80.5	M12	11.0

**S\_ + V\_**

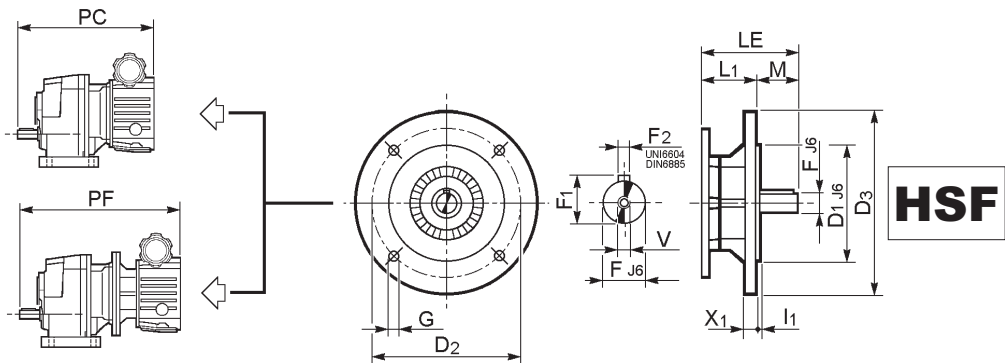

	D1	D2	D3	F	F1	F2	G	I1	LE	L1	M	V	X1	
<b>V 0.25</b>	95	115	140	11	12.5	4	8.5	3	58.5	37.5	21	M4	8	1.6
<b>V 0.5</b>	110	130	160	14	16	5	8.5	3.5	67	37	30	M5	8	2.5
<b>V 1</b>	130	165	200	19	21.5	6	11.5	3.5	88.5	48.5	40	M6	12	4.5
<b>V 2</b>	130	165	200	24	27	8	11.5	3.5	103.5	53.5	50	M8	12	5.9
<b>V 3</b>	180	215	250	28	31	8	14	4	121.5	61.5	60	M10	14	11.0
<b>V 5.5</b>	180	215	250	28	31	8	14	4	121.5	61.5	60	M10	14	11.0
<b>V 10</b>	230	265	300	38	41	10	14	5	160.5	80.5	80	M12	16	20

**S\_ + V\_**

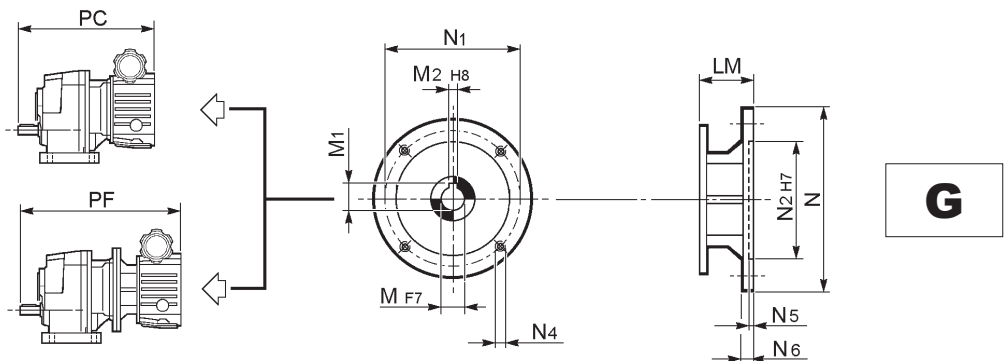

	LM	M	M1	M2	N	N1	N2	N4	N5	N6	
<b>V 0.25 G71</b>	42	14	16.3	5	160	130	110	M8	4.5	11	1.8
<b>V 0.5 G80</b>	54	19	21.8	6	200	165	130	M10	4.5	11.5	2.8
<b>V 1 G90</b>	59	24	27.3	8	200	165	130	M10	4.5	11.5	5.0
<b>V 2 G112</b>	67	28	31.3	8	250	215	180	M12	5	14	6.8
<b>V 3 G132</b>	88.5	38	41.3	10	300	265	230	M12	5	15	12.0
<b>V 5.5 G132</b>	88.5	38	41.3	10	300	265	230	M12	5	15	12.0
<b>V 10 G160</b>	120	42	45.3	12	350	300	250	M16	6	18	22

N.B. I pesi riportati in questa pagina si riferiscono alle sole entrate.

NOTE: Weights charted in this page apply to the additional input parts only.

HINWEIS: Die in dieser Tabelle angegebenen Gewichte beziehen sich nur auf den Antrieb.

N.B. : Les poids indiqués à cette page se réfèrent uniquement aux entrées.

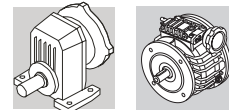

**VD\_P (IEC)**

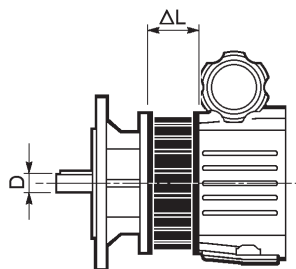

N.B. Le dimensioni mancanti sono riportate nelle pagine 120-129.

*N.B.: missing dimensions are listed on pages 120-129.*

ACHTUNG: Die fehlenden Maße werden auf den Seiten 120-129 angegeben.

*N.B. : Les dimensions manquantes sont indiquées pages 120-129.*

	D	ΔL	Kg
VD 0.5_P_	14	69	3.1
VD 1_P_	19	80.5	4.7
VD 2_P_	24	89.5	7.7
VD 3_P_	28	100.4	16.3
VD 5.5_P_	28	100.4	16.3
VD 10_P_	38	119.2	27.7

N.B. Il differenziale è applicabile esclusivamente ai variatori nella forma costruttiva UF. I pesi riportati in tabella si riferiscono al solo differenziale.

*N.B.: Differential will only fit UF type variators. Weight refer to differential only.*

HINWEIS: Das Differential kann ausschließlich nur an den Verstellgetrieben der Bauform UF appliziert werden. Die in dieser Tabelle angegebenen Gewichte beziehen sich nur auf das Differential.

*N.B. : Le différentiel est applicable uniquement aux variateurs dans la forme de construction UF. Les poids indiqués à cette page se réfèrent uniquement au différentiel.*

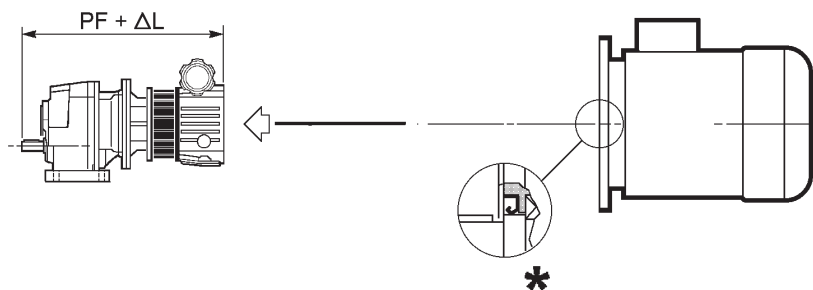

\* Nei variatori con differenziale, quando il motore elettrico è installato dall'utente, è necessario verificare che esso sia dotato di un anello di tenuta olio sull'albero montato secondo lo schema e che la flangia sia stagna. La tenuta olio fra la flangia motore e la flangia variatore è assicurata da una guarnizione fornita di serie sul variatore stesso.

*\* On fitting the electric motor onto variators featuring the differential unit make sure that the electric motor itself is oiltight and an oil seal is provided on drive end shaft. Sealing between flange of motor and variator is ensured by a gasket provided with the variator unit.*

\* Wenn der Elektromotor vom Kunden angebaut wird, ist es bei den Verstellgetrieben mit Differential erforderlich, die Motorwelle mit einem öldichten Wellendichtring auszustatten. Die Abdichtung zwischen Motor- und Verstellgetriebeflansch wird durch eine Dichtung gewährleistet, die beim Verstellgetriebe serienmäßig mitgeliefert wird.

*\* Sur les variateurs avec différentiel, lorsque le moteur électrique est installé par l'utilisateur, il est nécessaire de vérifier qu'il soit doté d'une bague d'étanchéité sur l'arbre monté selon le schéma. L'étanchéité à l'huile entre la bride moteur et la bride variateur est assurée par un joint fourni de série et présent sur le variateur.*

N.B. Le dimensioni e i pesi dei motori elettrici sono riportati nelle pag. 338-356.

*N.B. Dimensions and weights of electric motors are listed at page 338-356.*

ACHTUNG: Die Maße und Gewichte der Elektromotoren werden auf den Seiten 338-356 aufgeführt.

*N.B. : Les dimensions et les poids des moteurs électriques sont indiqués à pages 338-356.*

**Accessori:**

- CGY
- KITCGY
- ENTHS
- ENTG
- ENTN
- INDGRAV

Vedi pag. 88-94

**Accessories:**

- CGY
- KITCGY
- ENTHS
- ENTG
- ENTN
- INDGRAV

See page 88-94

**Zubehör:**

- CGY
- KITCGY
- ENTHS
- ENTG
- ENTN
- INDGRAV

Siehe Seite 88-94

**Accessoires:**

- CGY
- KITCGY
- ENTHS
- ENTG
- ENTN
- INDGRAV

Voir page 88-94

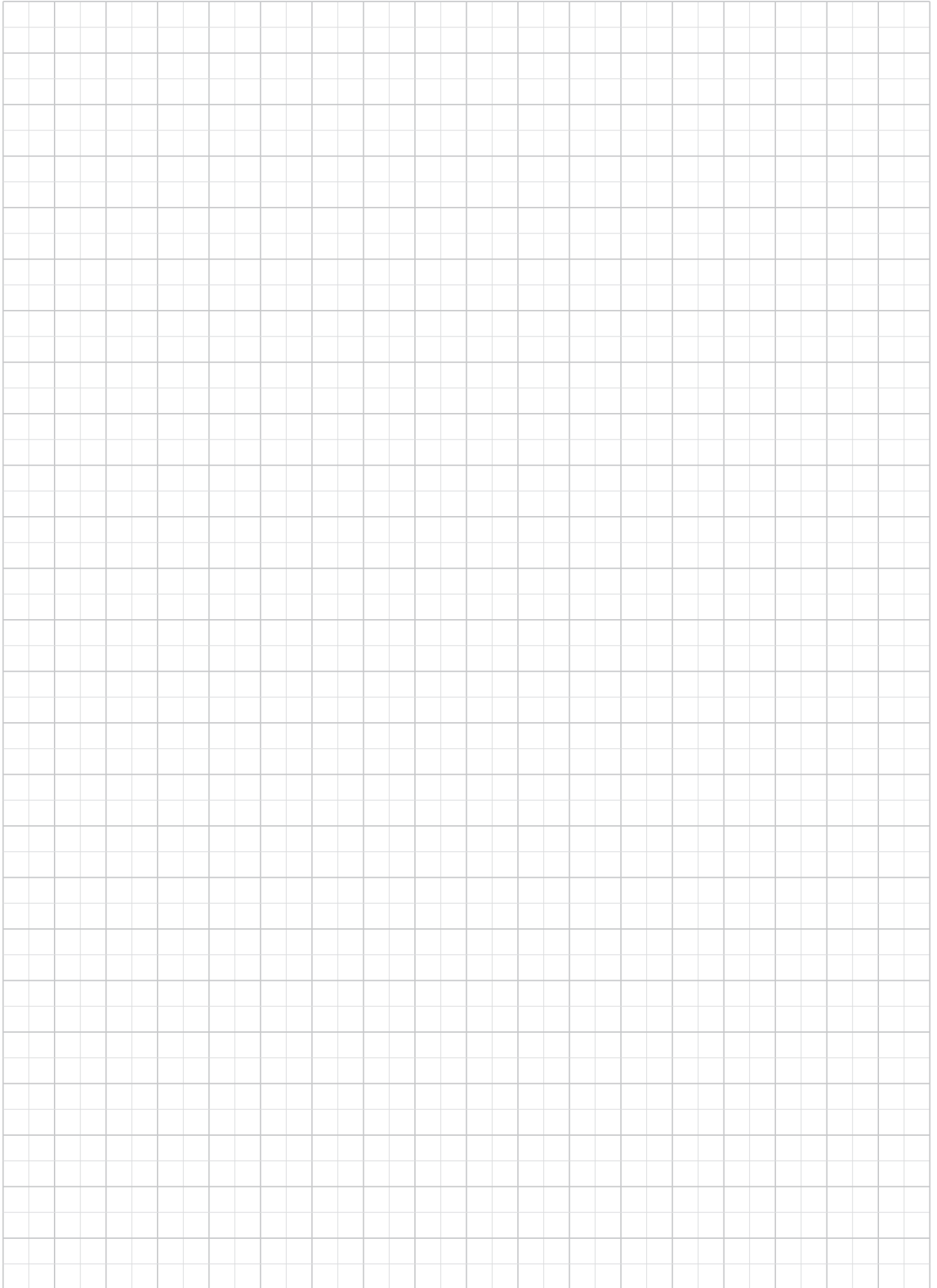
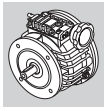
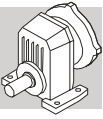

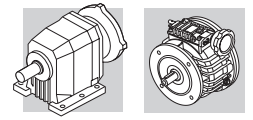

**22.0 - MOTOVARIARIDUTTORI**  
***MOTOVARIATOR-GEARBOX UNITS***  
**VERSTELLGETRIEBEMOTOREN**  
***MOTOVARIAREDUCTEURS***

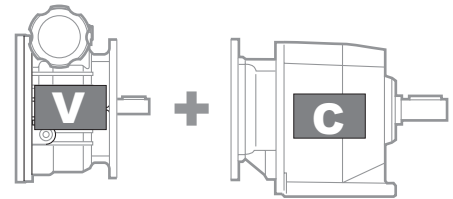

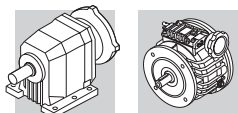

22.1 - Designazione riduttore

22.1 - Gearbox designation

22.1 - Getriebebezeichnung

22.1 - Désignation réducteur

**C 11 2 P 55.2 V05 B3 .....**

OPZIONI / OPTIONS  
OPTIONEN / OPTIONS

POS. DI MONTAGGIO / MOUNTING POSITION  
EINBAULAGEN / POS. DE MONTAGE

C...P : **B3** (Standard), **B6, B7, B8, V5, V6**  
C...F/U/UF : **B5** (Standard), **B51, B52, B53, V1, V3**

149

DESIGNAZIONE INGRESSO / INPUT DESIGNATION  
BEZEICHNUNG DER ANTRIEBSSEITE / DESIGNATION ENTREE

**V** + grandezza variatore = Predisposto per variatore compatto  
**V** + variator size = suitable to fit compact variator  
**V** + Verstellgetriebegröße = für kompaktes Verstellgetriebe geeignet  
**V** + grandeur variateur = prédisposé pour variateur compact

V025	V05	V1	V2	V3	V55	V10
V 0.25	V 0.5	V 1	V 2	V 3	V 5.5	V 10

**P** + grandezza motore = Predisposto per variatore flangiato  
**P** + motor size = suitable to fit flanged output variator  
**P** + Motorgröße = für geflanshtes Verstellgetriebe geeignet  
**P** + taille moteur = prédisposé pour variateur avec bride

P63	P71	P80	P90	P100	P112	P132
V 0.25	V 0.5	V 0.5 V 1	V 1 V 2	V 3	V 5.5	V 10

RAPPORTO DI RIDUZIONE / GEAR RATIO  
ÜBERSETZUNG / RAPPORT DE REDUCTION

FORMA COSTRUTTIVA / VERSION / BAUFORM / FORME DE CONSTRUCTION

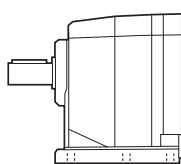

**P**  
(C11...C100)

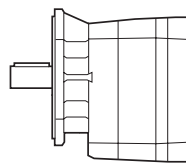

**F**  
(C11...C31)  
(C70...C100)

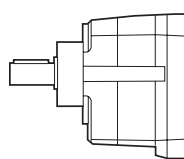

**U**  
(C11...C61)

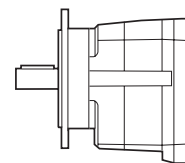

**UFA**  
**UFB**  
**UFC**  
(C11...C61)

N° STADI DI RIDUZIONE / N° OF REDUCTION STAGES  
ANZAHL DER GETRIEBESTUFEN / N.bre ETAGES DE REDUCTION

**2, 3, 4**

GRANDEZZA RIDUTTORE / GEARBOX SIZE / GETRIEBEBAUGRÖSSE / TAILLE REDUCTEUR

**11, 21, 31, 35, 41, 51, 61, 70, 80, 90, 100**

TIPO RIDUTTORE: **C** = coassiale      GEARBOX TYPE: **C** = helical in-line  
GETRIEBETYP: **C** = Stirnradgetriebe      TYP DU REDUCTEUR: **C** = coaxial



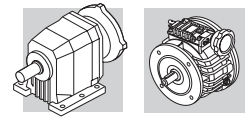

22.2 - Designazione variatore

22.2 - Designation of variator

22.2 - Bezeichnung für Drehzahlwandler

22.2 - Désignation variateur

**V**  **0.5** **C**   **P71** **B3** **1** **PDN** **SCT** ....

OPZIONI / OPTIONS  
OPTIONEN / OPTIONS

TIPO DI COMANDO / REMOTE CONTROL TYPE  
VERSTELLEINRICHTUNG / TYPE DE COMMANDE  
**A, VG, VA, VAG, SCT (3Ø), TC (1Ø)**

SONDA RILEVATRICE / SPEED SENSOR  
MEßSONDE / SONDE DE DETECTION  
**PDN, PDNA, PDP**

POSIZIONE DISPOSITIVO DI COMANDO / SPEED KNOB POSITION  
EINBAULAGE DER VERSTELLEINRICHTUNG / POSITION COMMANDE  
**1 (default), 2 (V 3...V 10)**

POSIZIONE DI MONTAGGIO / MOUNTING POSITION  
MOTOR BAUFORM / FORME DE CONSTRUCTION DU MOTEUR  
**B3 (default), B6, B7, B8, V5, V51, V52, V53, V6, V61, V62, V63**

149

CONFIGURAZIONE INGRESSO / INPUT CONFIGURATION  
BEZEICHNUNG DER ANTRIEBSSEITE / DESIGNATION ENTREE

- P (IEC)** - predisposizione IEC / Provided with IEC motor adaptor  
vorbereitet für den Anbau eines IEC-Motors / prédisposé IEC
- HS** - albero cilindrico / solid input shaft / freier Antriebswelle / arbre rapide sortant
- HSF** - albero cilindrico e flangia riportata / solid input shaft and bolt-on flange  
freier Antriebswelle und Flansch / arbre rapide sortant et adjonction de bride
- N (NEMA)** - predisposizione motore NEMA / provided with Nema motor adaptor  
vorbereitet für den Anschluß eines NEMA-Motors / prédisposé moteur NEMA
- G (IEC)** - flangia IEC maggiorata / provided with IEC extended adaptor  
mit zusätzlicher Baueinheit für IEC-Motore / avec module supplémentaire prédisposé IEC

DIAMETRO ALBERO LENTO / OUTPUT SHAFT BORE  
ABTRIEBSWELLE DURCHMESSER / DIAMETRE ARBRE LENT

**D +** diametro in mm / diameter in mm  
Durchmesser in mm / diamètre en mm **(11,14,...)**

<b>D11</b>	<b>D14</b>	<b>D19</b>	<b>D24</b>	<b>D28</b>	<b>D28</b>	<b>D38</b>
(V 0.25)	(V 0.5)	(V 1)	(V 2)	(V 3)	(V 5.5)	(V 10)

**IMP** albero in pollici / inch series shaft / Nema-Welle / arbre NEMA

TIPO DI FISSAGGIO (per gruppi tipo U) / OUTPUT CONFIGURATION (only for U version)  
MONTAGEMÖGLICHKEIT (ausschließlich für die Bauform U) / TIPE DE FIXATION (pour forme de construction U)

- F (IEC)** - flangia IEC riportata / bolt-on IEC flange / Flansch IEC / adjonction de bride IEC
- F (NEMA)** - flangia NEMA / NEMA flange mounted / NEMA Flansch / bride Nema

FORMA COSTRUTTIVA / VERSION / BAUFORM / VERSION

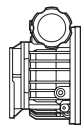

**C**

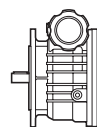

**F**

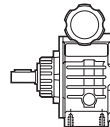

**U**

GRANDEZZA VARIATORE / VARIATOR SIZE / BAUGRÖSSE / TAILLE VARIATEUR  
**0.25, 0.5, 1, 2, 3, 5.5, 10**

DIFFERENZIALE / DIFFERENTIAL / DIFFERENTIAL / DIFFERENTIEL  
**D**

VARIATORE / VARIATOR TYPE / VERSTELLGETRIEBETYP / TYPE VARIATEUR  
**V**

22.3 - Designazione motore

22.3 - Motor designation

22.3 - Motor bezeichnung

22.3 - Désignation moteur

25

25

25

25

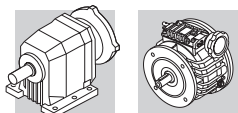

## 22.4 - Opzioni riduttori

### SO

I riduttori C11, C21, C31, C35, C41, solitamente forniti con lubrificante dalla BONFIGLIOLI RIDUTTORI, sono forniti privi di lubrificante.

### LO

I riduttori C51, C61, C70, C80, C90, C100 solitamente sprovvisti di lubrificante, sono richiesti con olio sintetico del tipo correntemente utilizzato dalla BONFIGLIOLI RIDUTTORI e riempiti in accordo alla posizione di montaggio richiesta.

### DL

L'albero lento è dotato di doppio anello di tenuta.

### VV

Anello di tenuta in fluoro-elastomero sull'albero veloce.

### PV

Tutti gli anelli di tenuta in fluoro-elastomero.

## 22.5 - Opzioni variatori

### CU

Cassa universale con piano di appoggio spianato e relativi fori di fissaggio (pag. 28).

### FL

Cassa universale con fianchi laterali spianati e relativi fori di fissaggio (pag. 28).

### PDN

Predisposizione al rilevamento di giri digitale incorporato all'interno del variatore con sonda rilevatrice di tipo NPN.

### PDP

Predisposizione al rilevamento di giri digitale incorporato all'interno del variatore con sonda rilevatrice di tipo PNP.

La tabella (E01) riporta le possibilità di applicazione e le dimensioni delle sonde NPN e PNP utilizzate.

## 22.4 - Gearbox options

### SO

*Gearboxes C11, C21, C31, C35, C41, supplied without oil.*

### LO

*Gearboxes C51, C61, C70, C80, C90, C100 usually supplied without oil, to be supplied with synthetic oil currently used by BONFIGLIOLI RIDUTTORI and filled according to requested mounting position.*

### DL

*The low speed shaft accommodates a dual oil seal.*

### VV

*Fluoro elastomer oil seal on input shaft.*

### PV

*All oil seals in Fluoro elastomer.*

## 22.5 - Variator options

### CU

*Universal casing featuring machined supporting surface with drilled and tapped holes (page 28).*

### FL

*Universal casing featuring machined sides with drilled and tapped holes (page 28).*

### PDN

*Configured for digital speed detection by NPN sensor incorporated into variator.*

### PDP

*Configured for digital speed detection by PNP sensor incorporated into variator.*

*Table (E01) shows which units support which options and provides the (plug thread) dimensions of the various NPN and PNP sensors used.*

## 22.4 - Getriebe Optionen

### SO

Bei Lieferung ohne Schmierstoff (nur bei C11, C21, C31, C35 und C41).

### LO

Für Getriebe C51, C61, C70, C80, C90, C100 die gewöhnlich ohne Schmiermittel geliefert werden, in Übereinstimmung mit der Einbaulage gefüllt mit dem normalerweise von BONFIGLIOLI RIDUTTORI verwendeten synthetischen Schmierstoff.

### DL

Die Abtriebswelle ist mit Doppeldichtung geliefert.

### VV

Wellendichtringe aus Fluor-Elastomer auf der eintreibenden Welle.

### PV

Alle Wellendichtringe aus Fluor-Elastomer.

## 22.5 - Optionen – Verstellgetriebemotor

### CU

Universalgehäuse mit plangeschliffener Auflagefläche und entsprechenden Befestigungsbohrungen (Seite 28).

### FL

Universalgehäuse mit plangeschliffenen Seitenflanken und entsprechenden Befestigungsbohrungen (Seite 28).

### PDN

Vorbereitet für im Verstellgetriebe eingebaute digitale Vorrichtung für die Drehzahlerhebung über eine NPN-Sonde.

### PDP

Vorbereitet für im Verstellgetriebe eingebaute digitale Vorrichtung für die Drehzahlerhebung über eine PNP-Sonde.

In der Tabelle (E01) werden die möglichen Applikationsmöglichkeiten der verwendeten NPN- und PNP-Sonden aufgeführt.

## 22.4 - Options réducteurs

### SO

*Les réducteurs C11, C21, C31, C35, C41, habituellement fournis avec lubrifiant par la société BONFIGLIOLI RIDUTTORI, sont demandés sans lubrifiant.*

### LO

*Les réducteurs C51, C61, C70, C80, C90, C100 habituellement dépourvus de lubrifiants, sont demandés avec huile synthétique du type couramment utilisé par BONFIGLIOLI RIDUTTORI et remplis conformément à la position de montage demandée.*

### DL

*L'arbre lent est équipé avec double joint d'étanchéité.*

### VV

*Bague d'étanchéité en Elastomère fluoré sur l'arbre rapide.*

### PV

*Toutes les bagues d'étanchéité en Elastomère fluoré.*

## 22.5 - Options variateurs

### CU

*Caisse universelle avec plan d'appui aplati et orifices de fixation correspondants (page 28).*

### FL

*Caisse universelle avec flancs latéraux aplatis et orifices de fixation correspondants (page 28)*

### PDN

*Prédisposition pour le dispositif de mesure du nombre de tours digital incorporé à l'intérieur du variateur avec sonde de détection de type NPN.*

### PDP

*Prédisposition pour le dispositif de mesure du nombre de tours digital incorporé à l'intérieur du variateur avec sonde de détection de type PNP.*

*Le tableau (E01) indique les différentes possibilités d'application ainsi que les dimensions des sondes NPN et PNP utilisées.*

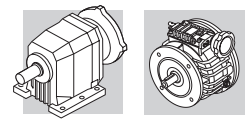

(E01)

Riduttore Gearbox Getriebe Réducteur	Sonda Plug thread Sonde Sonde (NPN/PNP)	Variatore Variator Verstellgetriebe Variateur	Forme costruttive / Versions Bauformen / Formes de construction		
			C	V	
				F-UF	V_D UF
C 112	M8x1	V 0.25	#		
	M8x1	V 0.5	#		
C 212	M8x1	V 0.25	#		
	M8x1	V 0.5	#		
	M10x1	V 1	#		
C 312	M8x1	V 0.25	#		
	M8x1	V 0.5	#		
	M10x1	V 1	#		
C 313	M8x1	V 0.25	#		
C 352 C 353	M8x1	V 0.25	#		
	M8x1	V 0.5	#		
	M10x1	V 1	#		
	M10x1	V 2	#		
	M12x1	V 3	#		
C 354	M8x1	V 0.25	#		
	M8x1	V 0.5	#		
	M10x1	V 1	#		
C 412 C 413	M8x1	V 0.5	#		
	M10x1	V 1	#		
	M12x1	V 3	#		
C 414	M8x1	V 0.25	#		
	M8x1	V 0.5	#		
	M10x1	V 1	#		
C 512 C 513	M10x1	V 1	#		
	M12x1	V 3/5.5	#		

Riduttore Gearbox Getriebe Réducteur	Sonda Plug thread Sonde Sonde (NPN/PNP)	Variatore Variator Verstellgetriebe Variateur	Forme costruttive / Versions Bauformen / Formes de construction		
			C	V	
				F-UF	V_D UF
C 514	M8x1	V 0.5	#		
	M10x1	V 1	#		
C 612 C 613	M10x1	V 1	#		
		V 2	#		
	M12x1	V 3/5.5			
C 614	M8x1	V 10			
		V 0.5	#		
	M10x1	V 1	#		
C 702	M12x1	V 2	#		
		V 3/5.5			
	V 10	—			
C 703	M10x1	V 1	#		
		V 2	#		
	M12x1	V 3/5.5			
C 802	M12x1	V 10	—		
		V 5.5	—		
	V 10	—			
C 803	M10x1	V 2	#		
	M12x1	V 3/5.5	—		
V 10		—			
C 902	M12x1	V 10	—		
C 903	M12x1	V 3/5.5	—		
		V 10	—		
C 1003	M12x1	V 10	—		

■ Applicazioni disponibili

■ Option availability

■ Zur Verfügung stehende  
Anwendungen

■ Applications disponibles

# Applicazione disponibile per le posizioni di montaggio B3, a richiesta (come esecuzione speciale) per le altre posizioni di montaggio.

# The option is available for units in the B3 mounting position. For other positions, please enquire with Bonfiglioli.

# Anwendung auch für die Montagepositionen B3 erhältlich; auf Anfrage (als Sonderausführung) auch für die anderen Montagepositionen.

# Application disponible pour les positions de montage B3, sur demande (exécution spéciale) pour les autres positions de montage.

#### PV

Anelli di tenuta in fluoro-elastomero.

#### PV

Fluoro elastomer seals.

#### PV

Dichtringe in Fluor-Elastomer.

#### PV

Bagues d'étanchéité en Elastomère fluoré.

#### SO

I variatori V 0.25 - V 10 solitamente forniti con lubrificante dalla Bonfiglioli Riduttori sono forniti privi di lubrificante. Questa opzione non è prevista per i variatori con differenziale V 0.5D - V 10D con ingresso P.. in quanto normalmente forniti privi di lubrificante.

#### SO

The V 0.25 - V 10 variators - normally factory-filled with oil - are supplied dry. This option is not available on the V 0.5D - V 10D variators with differential unit and P input, that are normally supplied dry.

#### SO

Die üblicherweise von der Bonfiglioli Riduttori mit Schmiermittel gelieferten Verstellgetriebe V 0.25 - V 10 werden bei dieser Ausführungsart ohne Schmiermittel geliefert. Diese Option ist bei den Verstellgetrieben mit Antrieb P.. VBG 0.5D - VBG 10D mit Differential nicht gegeben, da diese normalerweise ohne Schmiermittel geliefert werden.

#### SO

Les variateurs V 0.25-V 10 généralement fournis avec du lubrifiant par Bonfiglioli Riduttori sont fournis sans lubrifiant. Cette option n'est pas prévue pour les variateurs avec différentiel V 0.5D - V 10D avec entrée P.. dans la mesure où ils sont normalement fournis sans lubrifiant.

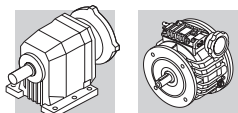

## 22.6 - Lubrificazione

### Lubrificazione riduttori serie C

Gli organi interni dei riduttori Bonfiglioli sono lubrificati con un sistema misto di immersione e sbattimento dell'olio.

I gruppi C11, C21, C31, C35 e C41 sono normalmente consegnati con carica di lubrificante dalla fabbrica, o dalla rete di vendita ufficiale.

I gruppi di grandezza C51 e superiori sono normalmente forniti privi di lubrificante, e sarà cura dell'utilizzatore riempirli di olio prima della messa in servizio.

In entrambi i casi, a seconda delle versioni, prima della messa in esercizio del riduttore potrebbe essere necessario sostituire il tappo chiuso usato per il trasporto con il tappo di sfiato fornito a corredo.

Le tavole che seguono sono da riferimento nell'interpretazione delle posizioni di montaggio, della collocazione dei tappi di servizio e delle quantità di lubrificante.

**Queste ultime sono indicative; per il corretto riempimento si dovrà fare riferimento tassativamente alla mezzeria del tappo di livello trasparente o all'astina (tacca di riferimento) o allo sfioramento del foro del tappo, quando presenti. Rispetto a questa condizione la quantità di lubrificante riportata in tabella può presentare scostamenti, occasionalmente anche rilevanti.**

Il lubrificante "long life" fornito di serie è di natura sintetica e, a meno di contaminazione dall'esterno, non richiede sostituzioni periodiche per tutto l'arco di vita del riduttore.

Il funzionamento dei riduttori è ammesso per temperature ambiente comprese fra  $-20^{\circ}\text{C}$  e  $+40^{\circ}\text{C}$ .

Per temperature ambiente comprese fra  $-20^{\circ}\text{C}$  e  $-10^{\circ}\text{C}$  l'avviamento del riduttore potrà avvenire solo dopo aver effettuato un pre-riscaldamento progressivo ed omogeneo del gruppo, oppure con funzionamento "a vuoto", senza carico collegato.

Il carico potrà poi essere applicato all'albero del riduttore quando la temperatura dello stesso avrà raggiunto la temperatura di  $-10^{\circ}\text{C}$ , o superiore.

## 22.6 - Lubrication

### Lubrication of C gearboxes

*The inner parts of Bonfiglioli gear units are oil-bath and splash lubricated.*

*Frame sizes C11, C21, C31, C35 and C41 are supplied by the factory, or by the authorized dealers, already filled with oil.*

*Unless otherwise specified, units size C51 and larger are usually supplied unlubricated at it will be the customer care to fill them with oil prior to putting them into operation.*

*In both cases, depending on the version, prior to putting the gear unit into operation may need to replace the closed plug used for transportation purposes with breather plug supplied with.*

*The charts here after must be referred to as for the mounting position pattern and the corresponding oil plugs, if applicable, and related lubricant quantity.*

***These figures are only indicative; to ensure correct filling, always refer to the centreline of the sight glass, the notch on the dipstick, or the spill level of the filler plug hole, whichever is present.***

***In some cases, discrepancies, occasionally also substantial, versus the oil quantities listed in the chart may be noticed.***

*The "long life" polyglycol-based lubricant supplied by the factory, in the absence of contamination, does not require periodic oil changes throughout the lifetime of the gear unit.*

*Operation of gear units is permitted at ambient temperatures between  $-20^{\circ}\text{C}$  and  $+40^{\circ}\text{C}$ .*

*However, for temperatures between  $-20^{\circ}\text{C}$  and  $-10^{\circ}\text{C}$  unit may only start up after it has been progressively and evenly pre-heated, or otherwise initially operated unloaded.*

*Load may then be connected to the output shaft when the gear unit has reached the temperature of  $-10^{\circ}\text{C}$ , or higher.*

## 22.6 - Schmierung

### Schmierung der Getriebe der Serie C

Die Schmierung der Getriebe von Bonfiglioli erfolgt durch eine Kombination aus Ölbad- und Tauchschiemung.

Die Getriebegrößen C11, C21, C31, C35 und C41 sind ab Werk mit einer Lebensdauerschmierung versehen.

Die Getriebe ab der Größe C51 werden ohne Ölfüllung ausgeliefert. Vor der Inbetriebnahme muss deshalb auf das Einfüllen der richtigen Ölfüllmenge geachtet werden!

In beiden Fällen, nach den Ausführungen, vor des Getriebe Inbetriebnahme, könnte notwendig sein, den geschlossenen Pfropfen mit dem Entlüftungspfropfen, der zusammen mit dem Getriebe geliefert ist, zu wechseln.

Bitte beachten Sie dazu auch die nachfolgenden Kapitel über die Positionen der Stopfen und Ölschaugläser und den entsprechenden Ölfüllmengen.

**Die Letztgenannten sind Richtwerte; zur korrekten Befüllung ist obligatorisch auf die Mittellinie des durchsichtigen Öleinfüllstopfens, den Messstab (Markierung) oder den Überlaufschutz des Stopfens, sofern vorhanden, Bezug zu nehmen. Auf Abweichungen gegenüber den in der Tabelle angegebenen Ölmengen, gelegentlich nicht unwesentliche, wird hingewiesen.**

Die mit Lebensdauerschmierung gelieferten Serien sind mit synthetischem Öl auf Polyglykolbasis gefüllt.

Falls dieses Öl nicht verunreinigt wird, ist während der Lebensdauer des Getriebes kein Ölwechsel nötig.

Die Getriebe dürfen bei einer Umgebungstemperatur von  $-20^{\circ}\text{C}$  bis  $+40^{\circ}\text{C}$  betrieben werden. Allerdings darf ein Start unter Last bei  $-20^{\circ}\text{C}$  bis  $-10^{\circ}\text{C}$  erst nach stufenweiser und gleichmäßiger Vorwärmung erfolgen. Anderfalls muss das Anfahren ohne Last erfolgen.

Die Last darf erst zugeschaltet werden, wenn die Getriebeeinheit eine Temperatur von mindestens  $-10^{\circ}\text{C}$  oder höher erreicht hat.

## 22.6 - Lubrification

### Lubrification réducteurs Série C

*Les organes internes des réducteurs Bonfiglioli sont lubrifiés avec un système mixte d'immersion et de battement de l'huile.*

*Les groupes C11, C21, C31, C35 et C41 sont normalement livrés avec charge de lubrifiant de l'usine, ou du réseau de vente officielle.*

*Les groupes de grandeur C51 et supérieur sont normalement fournis sans lubrifiant, et sera par l'utilisateur le remplissage d'huile avant la mise en service.*

*Dans les deux cas, selon les versions, avant la mise en service du réducteur, pourrait être nécessaire de remplacer le bouchon fermé utilisé pour le transport par le bouchon d'évent fourni.*

*Les tables suivantes sont de référence dans l'interprétation des positions de montage, du placement des bouchons de service et de la quantité de lubrifiant.*

***Ces dernières sont indicatives; pour un remplissage correct, il faut se référer obligatoirement au milieu du bouchon de niveau transparent ou à la jauge (encoche de repère) ou à l'effleurement du trou du bouchon, quand ils existent.***

***Par rapport à cette condition la quantité de lubrifiant indiqué dans le tableau peut présenter des écartements, occasionnellement considérables.***

*Le lubrifiant "long life"; fourni de série est de nature synthétique et, à moins de contamination par l'extérieur, il ne demande pas des remplacements périodiques pour tout l'arc de vie du réducteur.*

*Le fonctionnement des réducteurs est admis pour des températures ambiantes comprises entre  $-20^{\circ}\text{C}$  et  $+40^{\circ}\text{C}$ .*

*Pour des températures ambiantes comprises entre  $-20^{\circ}\text{C}$  et  $-10^{\circ}\text{C}$  le démarrage du réducteur est admis seulement après un préchauffage progressif et homogène, ou avec un fonctionnement « à vide », sans charge appliquée.*

*La charge pourra être ensuite appliquée à l'arbre du réducteur quand celui-ci aura atteint une température de  $-10^{\circ}\text{C}$ , ou supérieure.*

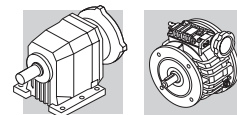

	Viscosità olio ISO VG / Oil viscosity ISO VG / Öl-Viskosität ISO VG / Viscosité de l'huile ISO VG				
	$T_a \leq -20^\circ$	$-20^\circ < T_a \leq 10^\circ$	$0^\circ \leq T_a \leq 30^\circ$	$20^\circ \leq T_a \leq 40^\circ$	$T_a > 40^\circ$
<b>Mineral EP</b>	(*)	150	320	460	460 (*)
<b>PAO EP</b>	(*)	150	220	320	460 (*)
<b>PAG</b>	(*)	150	220	320	460 (*)

**PAO** Oli sintetici polialfaolefine **PAO** Polyalphaolefin synthetic oils **PAO** Synthetische Poly-Alpha-Olefin-Öle **PAO** Huiles synthétiques polyalphaoléfinées

**PAG** Oli sintetici a base poliglicolica **PAG** Polyglycol-based synthetic oils **PAG** Synthetische Öl auf Polyglycol basierend **PAG** Huiles synthétiques à base de polyglycol

(\*) consultare il Servizio Tecnico Commerciale. (\*) consult Bonfiglioli Technical Service. (\*) Bitte wenden Sie sich an die technische Abteilung von Bonfiglioli. (\*) Consulter le service technique Bonfiglioli.





Quantità di lubrificante [ l ] Oil quantity [ l ] Schmiermittelmenge [ l ] Quantité de lubrifiant [ l ]

	oil [ l ]																	
	P						F						U - UF					
	B3	B6	B7	B8	V5	V6	B5	B51	B53	B52	V1	V3	B5	B51	B53	B52	V1	V3
<b>C 11 2</b>	0.50	0.45	0.40	0.60	0.50	0.70	0.45	0.40	0.35	0.55	0.45	0.60	0.45	0.40	0.35	0.55	0.40	0.60
<b>C 21 2</b>	0.70	0.65	0.70	0.80	0.85	1.2	0.65	0.65	0.65	0.75	0.80	1.1	0.65	0.60	0.65	0.75	0.75	0.95
<b>C 21 3</b>	1.0	1.0	1.2	1.2	1.3	1.5	1.0	1.0	1.2	1.2	1.2	1.4	0.95	0.95	1.1	1.1	1.1	1.3
<b>C 31 2</b>	1.0	1.0	1.0	1.2	1.5	1.5	1.0	1.0	1.0	1.2	1.4	1.4	0.95	0.95	0.95	1.2	1.3	1.3
<b>C 31 3</b>	1.0	1.0	1.2	1.2	1.3	1.5	1.0	1.0	1.2	1.2	1.2	1.4	0.95	0.95	1.1	1.1	1.1	1.3
<b>C 35 2</b>	1.6	1.5	1.5	1.3	2.1	2.4	—	—	—	—	—	—	1.6	1.5	1.5	1.3	2.1	2.4
<b>C 35 3</b>	1.5	1.4	1.5	1.3	2.0	2.3	—	—	—	—	—	—	1.5	1.4	1.5	1.3	2.0	2.3
<b>C 35 4</b>	2.3	2.1	2.3	2.1	2.7	3.1	—	—	—	—	—	—	2.3	2.1	2.3	2.1	2.7	3.1
<b>C 41 2</b>	2.2	2.0	2.1	1.9	2.7	3.4	—	—	—	—	—	—	2.2	2.0	2.1	1.9	2.7	3.4
<b>C 41 3</b>	2.1	1.9	2.1	1.9	2.6	3.2	—	—	—	—	—	—	2.1	1.9	2.1	1.9	2.6	3.2
<b>C 41 4</b>	2.8	2.6	2.8	2.6	3.5	3.9	—	—	—	—	—	—	2.8	2.6	2.8	2.6	3.5	3.9
<b>C 51 2</b>	3.1	3.0	3.1	3.0	4.3	5.0	—	—	—	—	—	—	3.1	3.0	3.1	3.0	4.3	5.0
<b>C 51 3</b>	3.0	2.8	3.1	3.0	4.1	4.9	—	—	—	—	—	—	3.0	2.8	3.1	3.0	4.1	4.9
<b>C 51 4</b>	4.3	4.1	4.4	4.2	5.4	6.1	—	—	—	—	—	—	4.3	4.1	4.4	4.2	5.4	6.1
<b>C 61 2</b>	4.2	4.0	4.2	4.1	6.0	6.7	—	—	—	—	—	—	4.2	4.0	4.2	4.1	6.0	6.7
<b>C 61 3</b>	4.2	4.0	4.2	4.1	6.0	6.7	—	—	—	—	—	—	4.2	4.0	4.2	4.1	6.0	6.7
<b>C 61 4</b>	6.1	5.9	6.1	6.0	7.9	8.6	—	—	—	—	—	—	6.1	5.9	6.1	6.0	7.9	8.6
<b>C 70 2</b>	6.5	8.5	8.5	7.5	11	7.5	6.5	8.5	8.5	7.5	11	7.5	—	—	—	—	—	—
<b>C 70 3</b>	6.5	8.5	8.5	7.5	11	7.5	6.5	8.5	8.5	7.5	11	7.5	—	—	—	—	—	—
<b>C 70 4</b>	6.5	8.5	8.5	7.5	11	8.0	6.5	8.5	8.5	7.5	11	7.5	—	—	—	—	—	—
<b>C 80 2</b>	11	14	14	13	18	13	11	14	14	13	18	13	—	—	—	—	—	—
<b>C 80 3</b>	11	14	14	13	18	13	11	14	14	13	18	13	—	—	—	—	—	—
<b>C 80 4</b>	11	14	14	13	18	13	11	14	14	13	18	13	—	—	—	—	—	—
<b>C 90 2</b>	19	25	25	22	31	22	19	25	25	22	31	22	—	—	—	—	—	—
<b>C 90 3</b>	19	25	25	22	31	22	19	25	25	22	31	22	—	—	—	—	—	—
<b>C 90 4</b>	19	25	25	22	31	22	19	25	25	22	31	22	—	—	—	—	—	—
<b>C 100 2</b>	27	37	37	33	45	33	27	37	37	33	45	33	—	—	—	—	—	—
<b>C 100 3</b>	27	37	37	33	45	33	27	37	37	33	45	33	—	—	—	—	—	—
<b>C 100 4</b>	27	37	37	33	45	33	27	37	37	33	45	33	—	—	—	—	—	—

 Lubrificazione a vita
  Life lubricated
  Dauerschmierung
  Lubrification permanente

 SHELL OMALA S4 WE 320 (for life)

**Collocazione dei tappi di carico, scarico e livello olio.** **Positions of oil fill, level and drain plugs.** **Anordnung des Einfüll-, Ölstands- und Ölablaßschrauben.** **Position des bouchons de remplissage, niveau et vidange d'huile.**

Legenda:	Key:	Zeichenerklärung:	Légende:
 Tappo di sfiato / carico	Filling / breather plug	Einfüll / Ablaßschraube	Bouchon de event / remplissage
 Tappo di livello	Level plug	Ölstandsschraube	Bouchon de niveau
 Tappo di scarico	Drain plug	Ölablaßschraube	Bouchon de vidange
 Tappo in vista	Plug in sight	Sichtbarer Deckel	Bouchon visible
 Tappo non in vista	Plug not in sight	Nicht sichtbarer Deckel	Bouchon non visible

Le pagine che seguono sono da riferimento per la collocazione dei tappi in relazione alla posizione di montaggio e ad altre variabili.

The following pages refer to plug position depending on reducer mounting position and other variables.

Die nachstehenden Seiten geben einen Hinweis in Bezug auf die Anordnung der jeweiligen Service-schrauben und die von der Einbaulage und anderen Variablen abhängige Schmiermittelmenge.

Les pages suivantes servent de référence pour le positionnement des bouchons de service en fonction de la position de montage et d'autres variables.

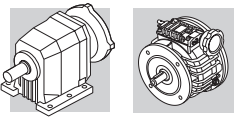

(E04)

# C 11 P ... C 41 P

P (IEC)		V		P (IEC)		V	
<b>B3</b>				<b>B8</b>			
(C35,C41)	(C11) (C35,C41) (C21,C31)					C11-C21-C31	2x
							3x
						C35-C41	
(C35,C41)	(C35,C41)					C21-C31	3x
							4x
						C35-C41	
<b>B6</b>				<b>V5</b>			
(C35,C41)	(C35,C41)	(C35,C41)	(C35,C41)	(C35,C41)	(C21, C31) (C35,C41)	(C11)	C11-C21-C31
(C11)	(C11)						2x
							2x
							3x
							C35-C41
(C35,C41)	(C35,C41)	(C35,C41)	(C35,C41)	(C35,C41)			C21-C31
							3x
							4x
							C35-C41
<b>B7</b>				<b>V6</b>			
(C11) (C35,C41)	(C11) (C35,C41)	(C11) (C35,C41)	(C11) (C35,C41)				C11-C21-C31
(C21, C31)	(C21, C31)	(C21, C31)	(C21, C31)				2x
							2x
							3x
							C35-C41
(C35,C41)	(C35,C41)	(C35,C41)	(C35,C41)				C21-C31
(C21,C31)	(C21,C31)	(C21,C31)	(C21,C31)				3x
							4x
							C35-C41

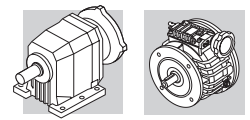

(E05)

# C 11 F/U ... C 41 F/U

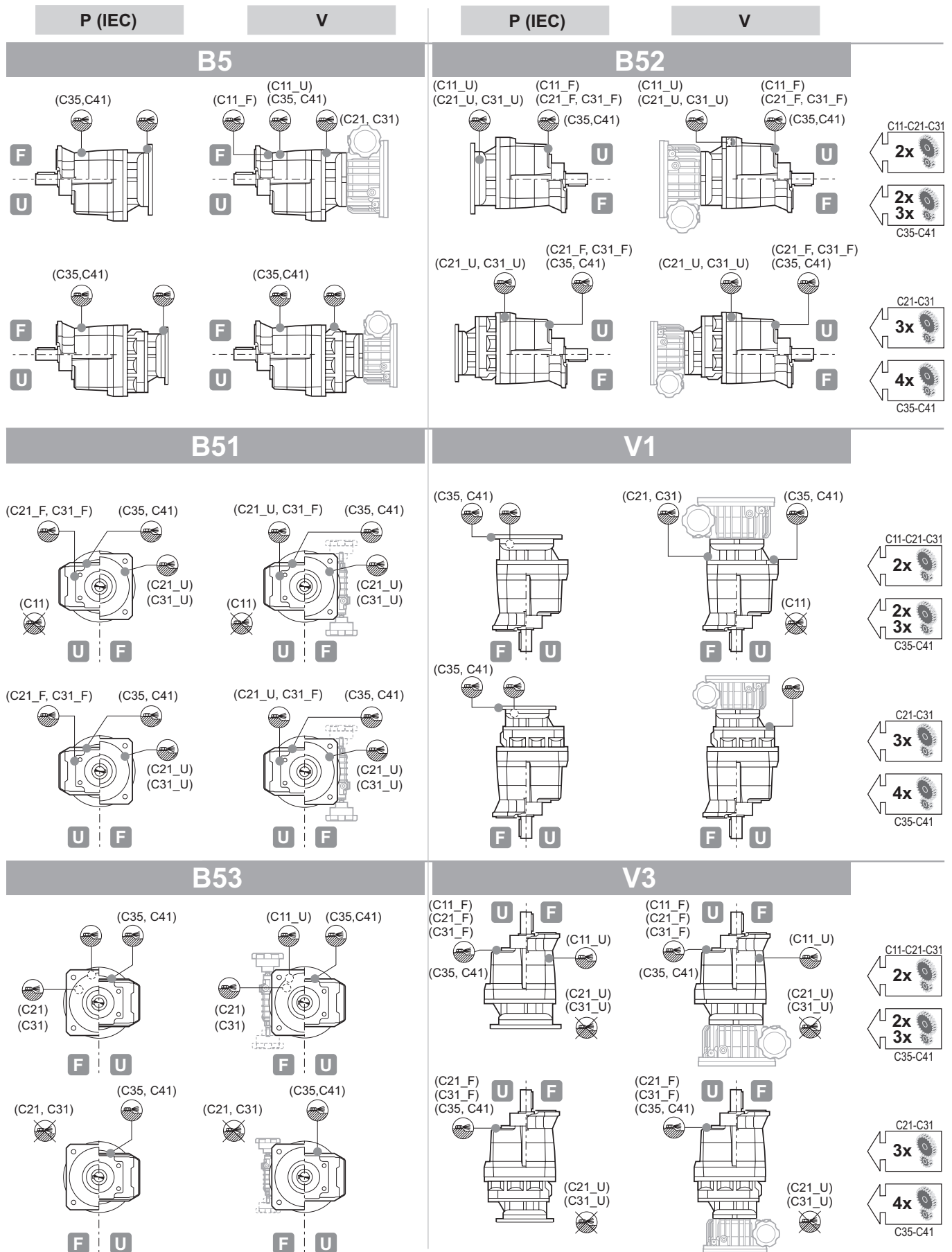

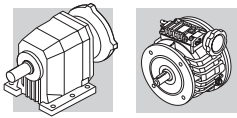

(E06)

# C 51 P ; C 61 P

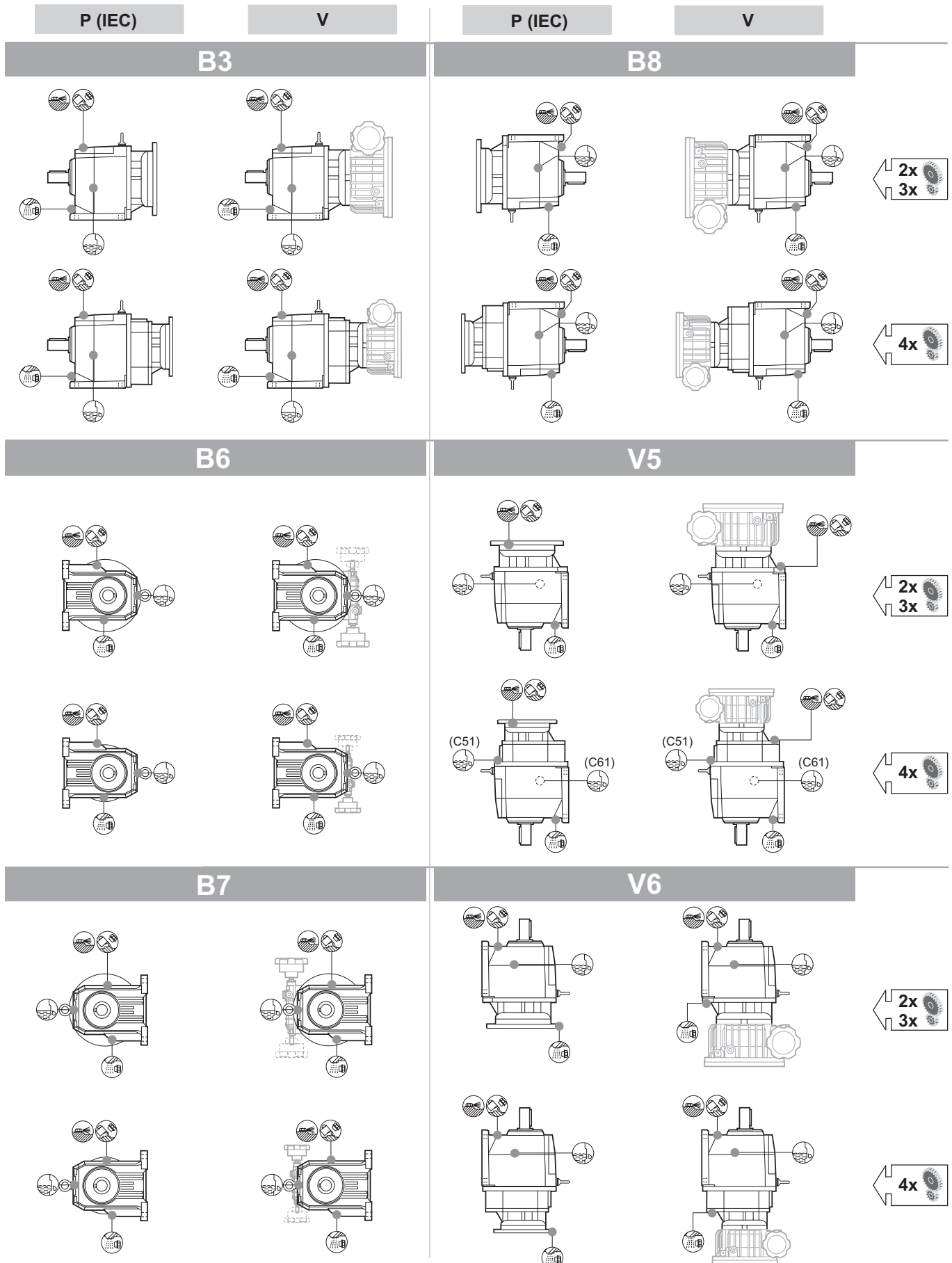



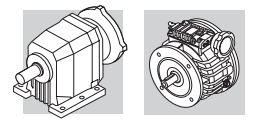

(E07)

# C 51 F/U ; C 61 F/U

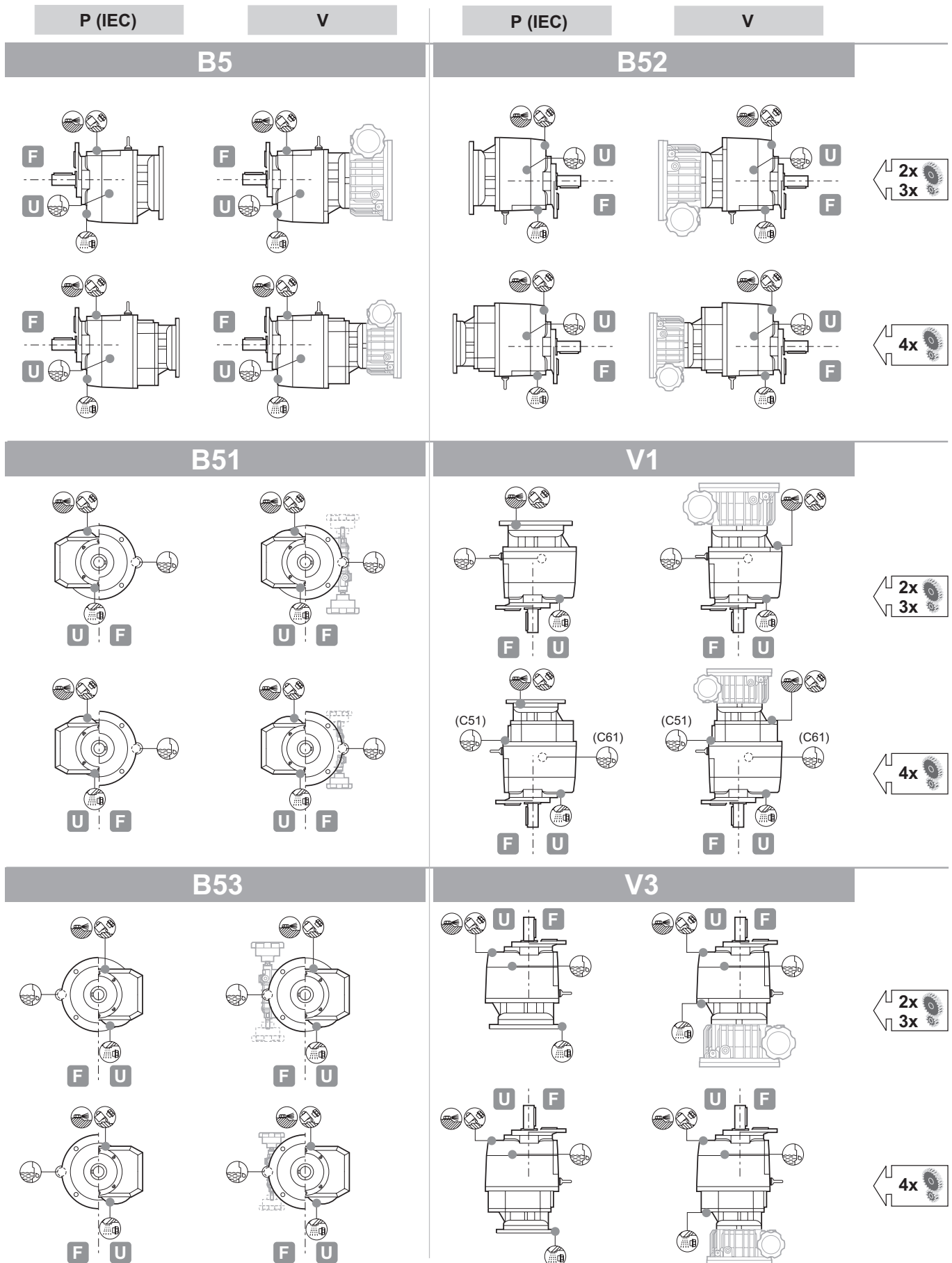

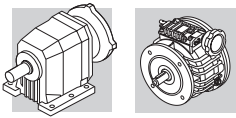

(E08)

# C 70 P ... C 100 P

P (IEC)		V		P (IEC)		V	
<b>B3</b>				<b>B8</b>			
<b>B6</b>				<b>V5</b>			
<b>B7</b>				<b>V6</b>			

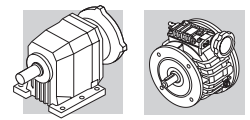

(E09)

# C 70 F ... C 100 F

P (IEC)		V		P (IEC)		V	
<b>B5</b>				<b>B52</b>			
<b>B51</b>				<b>V1</b>			
<b>B53</b>				<b>V3</b>			

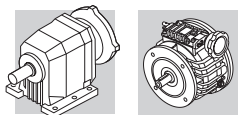

## Lubrificazione variatori

### V, VD

La lubrificazione dei variatori V e VD avviene per sbattimento dell'olio. Prima della messa in funzione dei variatori accertarsi della presenza di olio al loro interno assicurandosi che esso compaia nella spia di livello.

### VD

Tutti i variatori con differenziale VD completi di motore vengono forniti con carico di olio. Tutti i variatori con differenziale VD in configurazione P... (IEC), vengono forniti privi di olio. In questo caso l'utente dovrà provvedere al riempimento immettendo le quantità di olio indicate nelle tabelle (E10 - E11) e dovrà utilizzare motori elettrici con l'anello di tenuta lato albero e la flangia di accoppiamento al variatore a tenuta di olio.

**Benché i variatori siano abbinabili a qualsiasi motore normalizzato IEC, BONFIGLIOLI raccomanda che siano utilizzati solo motori originali, provvisti di anelli di tenuta per l'olio.**

I variatori V 0.25 e V 0.5 vengono forniti completi di olio lubrificante "long life" sintetico **SHELL SPIRAX S4 ATF HDX**. Eventuali sostituzioni o rabbocchi dovranno essere effettuati utilizzando lo stesso tipo di prodotto.

I variatori V 1...V 10 vengono forniti completi di olio lubrificante minerale **SHELL SPIRAX S2 ATF AX**. Eventuali sostituzioni o rabbocchi potranno essere effettuati utilizzando lubrificanti compatibili.

Riduzione **R** lubrificata "a vita" con grasso **SHELL GADUS S5 V142W 00**.

Tutti i variatori sono forniti con carica di lubrificante, ad eccezione dei tipi **VD\_P (IEC)**.

Il tappo di sfiato, fornito a corredo, va posizionato come indicato nelle tabelle (E10 - E11).

## Lubrication of variators

### V and VD

*Variators V and VD are splash-lubricated. Before putting the variator into operation make sure there is oil inside up to the sight glass level.*

### VD

*Motorized VD variators featuring the differential unit are factory filled with oil unlike VD variators with the IEC motor adapter (P...) which are supplied unlubricated and must be filled with oil prior to be put into operation. Proper oil quantity is shown in table (E10 - E11) for each mounting position.*

**Although speed variators can match any IEC motors, BONFIGLIOLI recommends the use of genuine motors only, complete with oil seals.**

*Variator units V 0.25 and V 0.5 are factory filled with "long life" synthetic oil **SHELL SPIRAX S4 ATF HDX**. Use same oil when topping up or refilling.*

*Variator units V 1 through V 10 are factory filled with mineral oil **SHELL SPIRAX S2 ATF AX**. Use same type of oil when topping up or refilling.*

*Helical reduction **R** is grease lubed "for life" with **SHELL GADUS S5 V142W 00**.*

*All speed variators are factory filled with lubricant, with the only exception of units type **VD\_P (IEC)**.*

*The breather plug, supplied along with every unit, shall be located as per the schemes (E10 - E11).*

## Schmierung der Verstellgetriebe

### V, VD

Die Schmierung der Verstellgetriebe V und VD erfolgt durch Tauchschmierung im Ölbad. Vor der Inbetriebnahme der Verstellgetriebe muß geprüft werden, ob sie bis zur Ölstandskontrolle mit Öl gefüllt sind.

### VD

Alle Verstellgetriebe mit Differential VD und Motor, sind bei Lieferung mit Öl gefüllt. Alle Verstellgetriebe mit Differential V-D für den Anbau eines IEC-Motors werden ohne Öl geliefert. Wenn der Kunde die Getriebe selbst mit Öl füllt, müssen die in Tabelle (E10 - E11) angegebenen Ölmengen verwendet werden. Die zu verwendenden Motoren müssen einen Dichtring auf der Seite der Welle haben und der Flansch zur Kopplung an das Verstellgetriebe muß öldicht sein.

**Es wird empfohlen, die Verstellgetriebe mit Differential mit öldichten BONFIGLIOLI RIDUTTORI Motoren zu kaufen.**

Die Verstellgetriebe V 0.25 und V 0.5 werden mit Schmieröl **SHELL SPIRAX S4 ATF HDX** geliefert. Eventuelle Ölwechsel oder Nachfüllungen müssen unter Anwendung des gleichen Produkttyps erfolgen.

Die Verstellgetriebe V 1...V 10 werden mit dem Schmieröl **SHELL SPIRAX S2 ATF AX** geliefert. Ein eventueller Wechsel oder ein etwaiges Auffüllen sollte unter Verwendung der Schmiermittel erfolgen.

Die Vorstufe **R** ist mit Fett Typ **SHELL GADUS S5 V142W 00** gefüllt.

Alle Verstellgetriebe sind ab Werk mit Öl gefüllt, außer dem Typ **VD\_P (IEC)**.

Der Entlüftungsstopfen, der jedem Getriebe beiliegt, muss entsprechend der obigen Skizze montiert werden.

## Lubrification variateurs

### V, VD

*La lubrification des variateurs V et VD s'effectue par barbotage de l'huile. Avant la mise en service des variateurs/motovariateurs, vérifier la présence d'huile à l'intérieur en contrôlant que celle-ci apparaisse dans le témoin de niveau.*

### VD

*Tous les variateurs avec différentiel VD avec moteur sont fournis avec le plein d'huile. Tous les variateurs avec différentiel VD en configuration P... (IEC) sont fournis sans huile. Dans ce cas, l'utilisateur doit effectuer le remplissage en versant la quantité d'huile indiquée dans le tableau (E10 - E11) et doit utiliser des moteurs électriques avec bague d'étanchéité côté arbre et bride d'accouplement au variateur étanche à l'huile.*

**Dans tous les cas, il est conseillé d'acquérir des variateurs avec différentiel avec moteurs avec étanchéité à l'huile BONFIGLIOLI RIDUTTORI.**

*Les variateurs V 0.25 et V 0.5 sont fournis avec de l'huile lubrifiante "long life" **SHELL SPIRAX S4 ATF HDX**. Utiliser le même type d'huile pour les éventuels vidanges ou remplissages.*

*Les variateurs V 1...V 10 sont fournis avec de l'huile lubrifiante **SHELL SPIRAX S2 ATF AX**. Utiliser le même type d'huiles pour les éventuels vidanges ou remplissages.*

*Réduction **R** avec lubrification permanente au moyen de graisse **SHELL GADUS S5 V142W 00**.*

*Tous les variateurs sont fournis avec le lubrifiant, à l'exception des les models **VD\_P (IEC)**.*

*Le bouchon d'évent, fourni avec chaque variateur, doit être positionné comme indiqué dans les schémas (E10 - E11).*



Non mescolare oli di natura diversa.



Do not mix synthetic oil with mineral oil.



Auf keinen Fall darf synthetisches Öl mit mineralischem gemischt werden!



Ne pas mélanger huiles de nature différente.

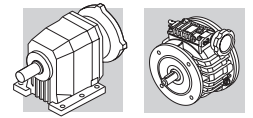

Collocazione dei tappi di carico, scarico e livello olio, scarico e livello olio.

Positions of oil fill, level and drain plugs.

Anordnung des Einfüll-, Ölstands- und Ölablaßschrauben.

Position des bouchons de remplissage, niveau et vidange d'huile.

(E10)

V 0.25 - V 0.5

V 1 - V 2

B3

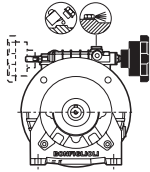

V 0.25 F	0.14	
V 0.5 F	0.18	
V 0.25 U / VR 0.25_	0.12	
V 0.5 U_ / VR 0.5_	0.15	
VD 0.5 U_ / VRD 0.5	0.30	

Oil SPIRAX S4 ATF HDX (for life)

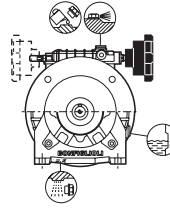

V 1 F	0.30	
V 2 F	0.40	
V 1 U_ / VR 1_	0.25	
V 2 U_ / VR 2_	0.32	
VD 1 U_ / VRD 1	0.35	
VD 2 U_ / VRD 2	0.46	

Oil SPIRAX S2 ATF AX (2000-3000 hrs.)

B6

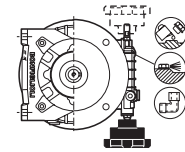

V 0.25 F	0.14	
V 0.5 F	0.18	
V 0.25 U / VR 0.25_	0.12	
V 0.5 U_ / VR 0.5_	0.15	
VD 0.5 U_ / VRD 0.5	0.30	

Oil SPIRAX S4 ATF HDX (for life)

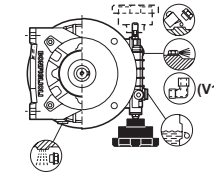

V 1 F	0.30	
V 2 F	0.40	
V 1 U_ / VR 1_	0.25	
V 2 U_ / VR 2_	0.32	
VD 1 U_ / VRD 1	0.35	
VD 2 U_ / VRD 2	0.46	

Oil SPIRAX S2 ATF AX (2000-3000 hrs.)

B7

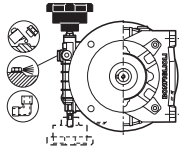

V 0.25 F	0.14	
V 0.5 F	0.18	
V 0.25 U / VR 0.25_	0.12	
V 0.5 U_ / VR 0.5_	0.15	
VD 0.5 U_ / VRD 0.5	0.30	

Oil SPIRAX S4 ATF HDX (for life)

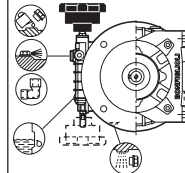

V 1 F	0.30	
V 2 F	0.40	
V 1 U_ / VR 1_	0.25	
V 2 U_ / VR 2_	0.32	
VD 1 U_ / VRD 1	0.35	
VD 2 U_ / VRD 2	0.46	

Oil SPIRAX S2 ATF AX (2000-3000 hrs.)

B8

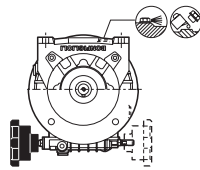

V 0.25 F	0.14	
V 0.5 F	0.18	
V 0.25 U / VR 0.25_	0.12	
V 0.5 U_ / VR 0.5_	0.15	
VD 0.5 U_ / VRD 0.5	0.30	

Oil SPIRAX S4 ATF HDX (for life)

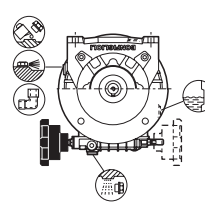

V 1 F	0.30	
V 2 F	0.40	
V 1 U_ / VR 1_	0.25	
V 2 U_ / VR 2_	0.32	
VD 1 U_ / VRD 1	0.35	
VD 2 U_ / VRD 2	0.46	

Oil SPIRAX S2 ATF AX (2000-3000 hrs.)

V5

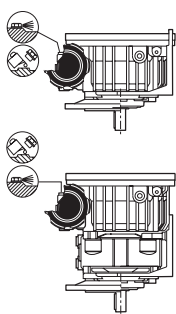

V 0.25 F	0.28	
V 0.5 F	0.30	
V 0.25 U / VR 0.25_	0.22	
V 0.5 U_ / VR 0.5_	0.27	

Oil SPIRAX S4 ATF HDX (for life)

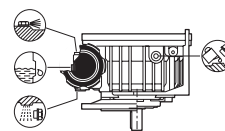

V 1 F	0.58	
V 2 F	0.78	
V 1 U_ / VR 1_	0.40	
V 2 U_ / VR 2_	0.54	

Oil SPIRAX S2 ATF AX (2000-3000 hrs.)

VD 0.5 U_ / VRD 0.5	0.70	
---------------------	------	--

Oil SPIRAX S4 ATF HDX (for life)

VD 1 U_ / VRD 1	1.00	
VD 2 U_ / VRD 2	1.5	

Oil SPIRAX S2 ATF AX (2000-3000 hrs.)

V6

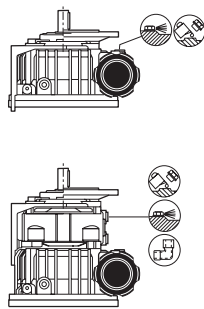

V 0.25 F	0.14	
V 0.5 F	0.18	
V 0.25 U / VR 0.25_	0.12	
V 0.5 U_ / VR 0.5_	0.15	

Oil SPIRAX S4 ATF HDX (for life)

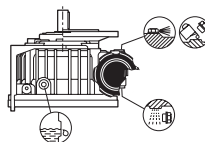

V 1 F	0.30	
V 2 F	0.40	
V 1 U_ / VR 1_	0.25	
V 2 U_ / VR 2_	0.32	

Oil SPIRAX S2 ATF AX (2000-3000 hrs.)

VD 0.5 U_ / VRD 0.5	0.40	
---------------------	------	--

Oil SPIRAX S4 ATF HDX (for life)

VD 1 U_ / VRD 1	0.50	
VD 2 U_ / VRD 2	0.70	

Oil SPIRAX S2 ATF AX (2000-3000 hrs.)

Tappo di sfiato  
Breather plug  
Entlüftungstopfen  
Bouchon d'évent

Tappo di carico  
Filler plug  
Einfüllstopfen  
Bouchon de remplissage

Tappo di scarico  
Drain plug  
Ablassstopfen  
Bouchon de vidange

Tappo di livello  
Level plug  
Ölstandsstopfen  
Bouchon de niveau

Raccordo orientabile  
90° elbow  
90° Winkel  
Raccord coudé

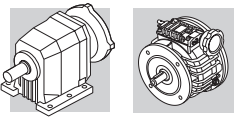

Collocazione dei tappi di carico, scarico e livello olio.

Positions of oil fill, level and drain plugs.

Anordnung des Einfüll-, Ölstands- und Ölablaßschrauben.

Position des bouchons de remplissage, niveau et vidange d'huile.

(E11)

V 3 - V 5.5

V 10

**B3**

V 3 F - V 5.5 F_	0.70	
V 3 U / VR 3 V 5.5 U / VR 5.5	1.0	
VD 3 F VD 5.5 F	1.3	
VD 3 U / VRD 3 U VD 5.5 U / VRD 5.5 U_	1.6	
Oil SPIRAX S2 ATF AX (2000-3000 hrs.)		

V 10 F V 10 U_ / VR 10	1.8	
VD 10 F VD 10 U_ / VRD 10 U_	2.0	
Oil SPIRAX S2 ATF AX (2000-3000 hrs.)		

**B6**

V 3 F - V 5.5 F_	0.90	
V 3 U / VR 3 V 5.5 U / VR 5.5	1.0	
VD 3 F VD 5.5 F	1.3	
VD 3 U / VRD 3 U VD 5.5 U / VRD 5.5 U_	1.6	
Oil SPIRAX S2 ATF AX (2000-3000 hrs.)		

V 10 F V 10 U_ / VR 10	1.8	
VD 10 F VD 10 U_ / VRD 10 U_	2.0	
Oil SPIRAX S2 ATF AX (2000-3000 hrs.)		

**B7**

V 3 F - V 5.5 F_	0.90	
V 3 U / VR 3 V 5.5 U / VR 5.5	1.0	
VD 3 F VD 5.5 F	1.3	
VD 3 U / VRD 3 U VD 5.5 U / VRD 5.5 U_	1.6	
Oil SPIRAX S2 ATF AX (2000-3000 hrs.)		

V 10 F V 10 U_ / VR 10	1.8	
VD 10 F VD 10 U_ / VRD 10 U_	2.0	
Oil SPIRAX S2 ATF AX (2000-3000 hrs.)		

**B8**

V 3 F - V 5.5 F_	1.0	
V 3 U / VR 3 V 5.5 U / VR 5.5	1.3	
VD 3 F VD 5.5 F	1.6	
VD 3 U / VRD 3 U VD 5.5 U / VRD 5.5 U_	1.9	
Oil SPIRAX S2 ATF AX (2000-3000 hrs.)		

V 10 F V 10 U_ / VR 10	2.1	
VD 10 F VD 10 U_ / VRD 10 U_	2.1	
Oil SPIRAX S2 ATF AX (2000-3000 hrs.)		

**V5**

V 3 F - V 5.5 F_	2.1	
V 3 U / VR 3 V 5.5 U / VR 5.5	2.0	
Oil SPIRAX S2 ATF AX (2000-3000 hrs.)		
VD 3 F VD 5.5 F	4.5	
VD 3 U / VRD 3 U VD 5.5 U / VRD 5.5 U_	4.8	
Oil SPIRAX S2 ATF AX (2000-3000 hrs.)		

V 10 F V 10 U_ / VR 10	3.2	
Oil SPIRAX S2 ATF AX (2000-3000 hrs.)		
VD 10 F VD 10 U_ / VRD 10	8.5	
Oil SPIRAX S2 ATF AX (2000-3000 hrs.)		

**V6**

V 3 F - V 5.5 F_	1.0	
V 3 U / VR 3 V 5.5 U / VR 5.5	1.3	
Oil SPIRAX S2 ATF AX (2000-3000 hrs.)		
VD 3 F VD 5.5 F	2.8	
VD 3 U / VRD 3 U VD 5.5 U / VRD 5.5 U_	3.0	
Oil SPIRAX S2 ATF AX (2000-3000 hrs.)		

V 10 F V 10 U_ / VR 10	2.8	
Oil SPIRAX S2 ATF AX (2000-3000 hrs.)		
VD 10 F VD 10 U_ / VRD 10	7.0	
Oil SPIRAX S2 ATF AX (2000-3000 hrs.)		

Tappo di sfiato  
Breather plug  
Entlüftungstopfen  
Bouchon d'évent

Tappo di carico  
Filler plug  
Einfüllstopfen  
Bouchon de remplissage

Tappo di scarico  
Drain plug  
Ablasstopfen  
Bouchon de vidange

Tappo di livello  
Level plug  
Ölstandsstopfen  
Bouchon de niveau

Raccordo orientabile  
90° elbow  
90° Winkel  
Raccord coudé

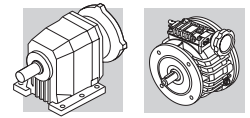

**22.7 - Posizioni di montaggio, orientamento morsetteria motore e comando variatore**

**22.7 - Mounting position, motor terminal box angular position and variator control**

**22.7 - Einbaulagen, lage des Motorklemmenkastens und position der Steuerung des Verstellgetriebe**

**22.7 - Positions de montage, orientation boîte a borne du moteur et dispositif de commande variateur**

Le tabelle (E13...E15) evidenziano le posizioni che può assumere il variatore rispetto alla posizione di montaggio del riduttore.

In fase di ordine è necessario specificare oltre alla posizione di montaggio del riduttore anche la posizione del variatore, l'orientamento della morsetteria (W, N, E, S) e del comando (1, 2) scegliendo fra le alternative illustrate nelle tabelle.

La tabella (E12) facilita l'interpretazione delle varie posizioni di montaggio riportate.

Tables (E13...E15) show the mounting positions of the variator depending on reducer mounting position.

Reducer mounting position and variator arrangement must be specified on order, as well as terminal board arrangement (W, N, E, S) and control position (1, 2). Choose from the options shown in the tables.

Table (E12) provides examples of the various mounting positions for better understanding.

Die Tabellen (E13...E15) stellen die Positionen dar, die das Verstellgetriebe den Einbaulagen des Getriebes gegenüber einnehmen kann.

In der Auftragsphase muß daher über die Montageposition des Getriebes hinaus, auch die Lage des Verstellgetriebes, die Ausrichtung der Klemmenleiste (W, N, E, S) und position der Steuerung angegeben werden, die unter den in der Tabelle angegebenen Möglichkeiten ausgewählt werden können.

Die Tabelle (E12) erleichtert die Auslegung der verschiedenen, dargestellten Einbaulagen.

Les tableaux (E13...E15) indiquent les positions possibles du variateur par rapport à la position de montage du réducteur. Au moment de la commande, il est nécessaire de préciser la position de montage du réducteur ainsi que la position du variateur, l'orientation de la boîte à bornes (W, N, E, S) et la position du dispositif de commande (1, 2), en choisissant parmi les alternatives indiquées dans les tableaux.

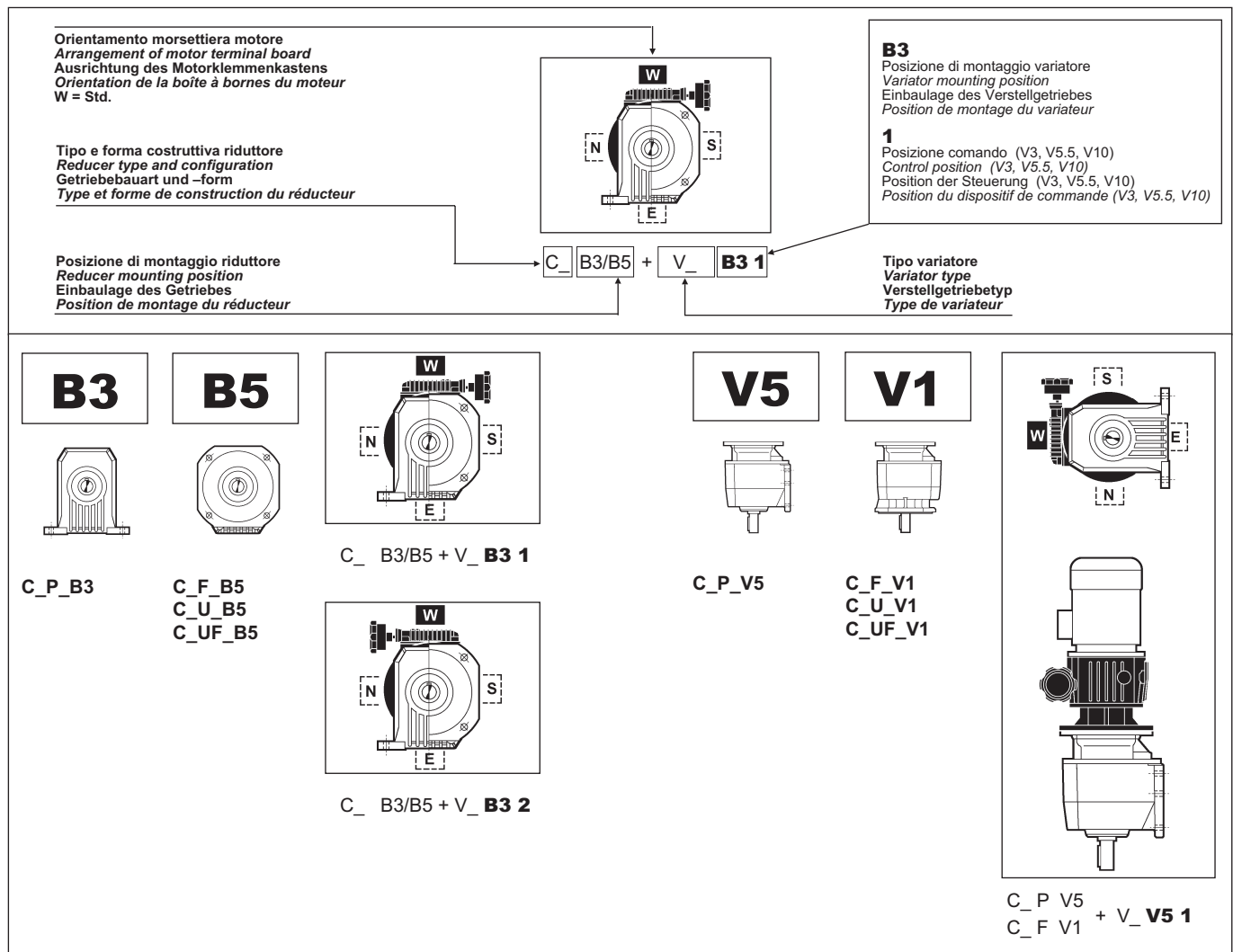

Le tableau (E12) facilite l'interprétation des différentes positions de montage indiquées.

(E12)

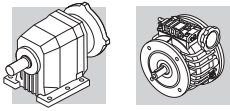



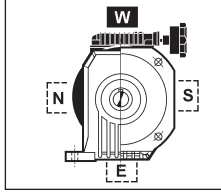
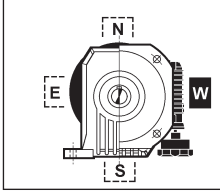
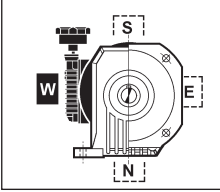
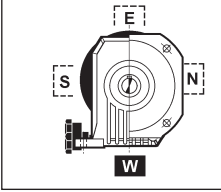
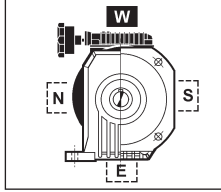
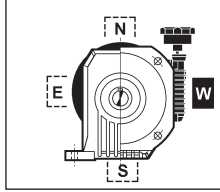
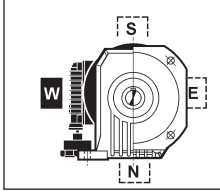
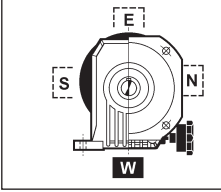
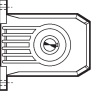
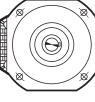
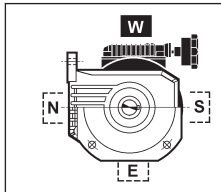
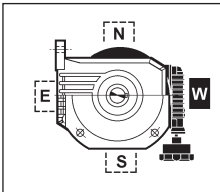
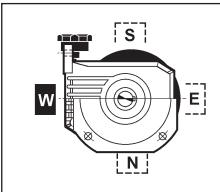
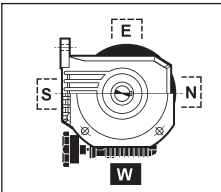
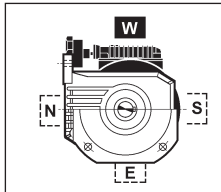
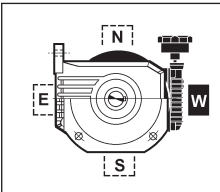
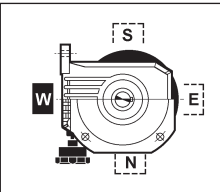
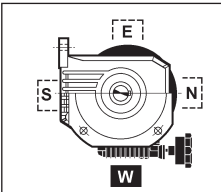
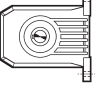
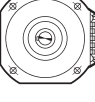
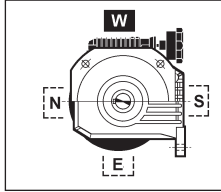
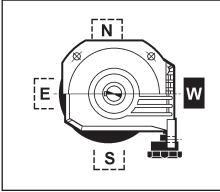
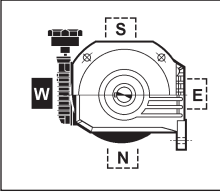
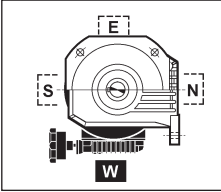
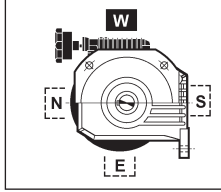
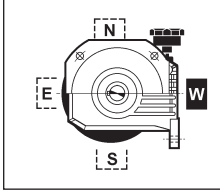
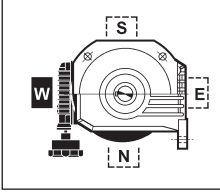
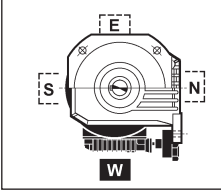

(E13)

<p><b>B3</b></p> 	<p><b>B5</b></p> 				
<p>C_P_B3</p>	<p>C_F_B5 C_U_B5 C_UF_B5</p>	<p>C_ B3/B5 + V_ <b>B3 1</b></p> 	<p>C_ B3/B5 + V_ <b>B6 1</b></p> 	<p>C_ B3/B5 + V_ <b>B7 1</b></p> 	<p>C_ B3/B5 + V_ <b>B8 1</b></p> 
<p><b>B6</b></p> 	<p><b>B51</b></p> 				
<p>C_P_B6</p>	<p>C_F_B51 C_U_B51 C_UF_B51</p>	<p>C_ B6/B51 + V_ <b>B3 1</b></p> 	<p>C_ B6/B51 + V_ <b>B6 1</b></p> 	<p>C_ B6/B51 + V_ <b>B7 1</b></p> 	<p>C_ B6/B51 + V_ <b>B8 1</b></p> 
<p><b>B7</b></p> 	<p><b>B53</b></p> 				
<p>C_P_B7</p>	<p>C_F_B53 C_U_B53 C_UF_B53</p>	<p>C_ B7/B53 + V_ <b>B3 1</b></p> 	<p>C_ B7/B53 + V_ <b>B6 1</b></p> 	<p>C_ B7/B53 + V_ <b>B7 1</b></p> 	<p>C_ B7/B53 + V_ <b>B8 1</b></p> 

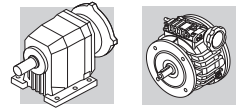

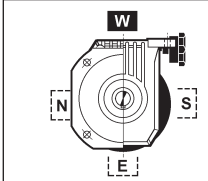
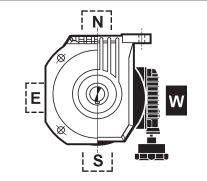
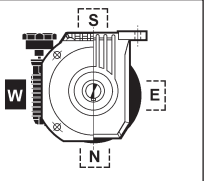
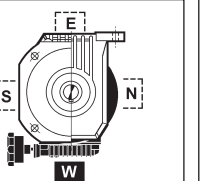
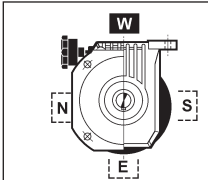
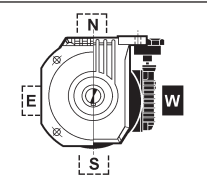
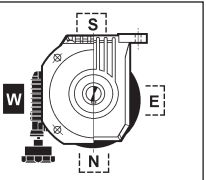
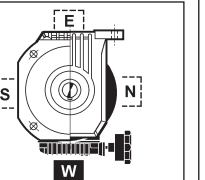
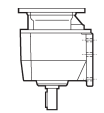
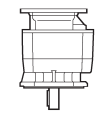
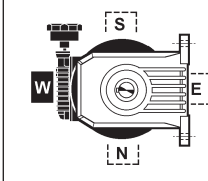
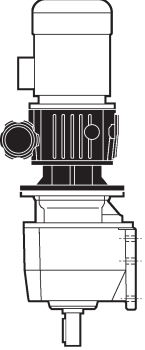
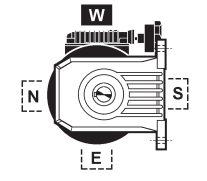
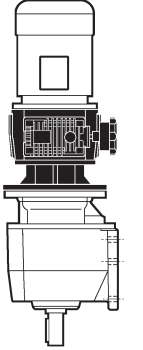
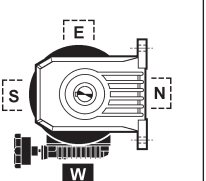
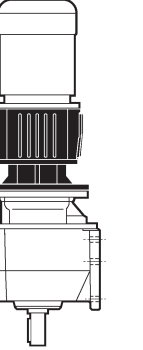
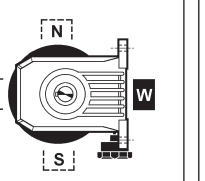
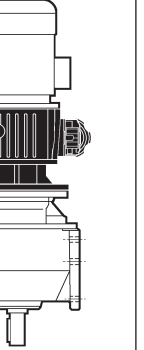
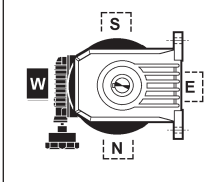
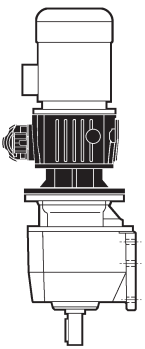
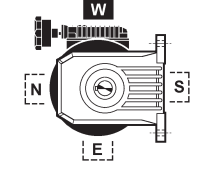
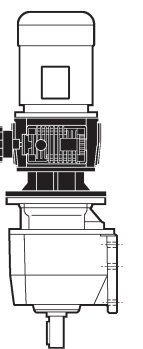
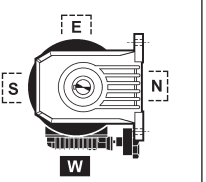
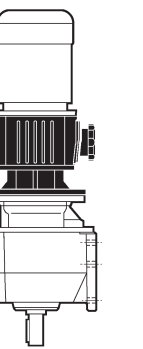
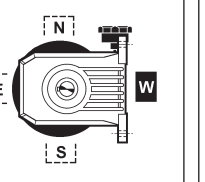
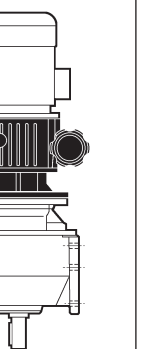

(E14)

<p><b>B8</b></p> 	<p><b>B52</b></p> 				
<p>C_P_B8</p>	<p>C_F_B52 C_U_B52 C_UF_B52</p>				
		<p>C_ B8/B52+ V_ <b>B3 2</b></p>	<p>C_ B8/B52+ V_ <b>B6 2</b></p>	<p>C_ B8/B52+ V_ <b>B7 2</b></p>	<p>C_ B8/B52+ V_ <b>B8 2</b></p>
<p><b>V5</b></p> 	<p><b>V1</b></p> 	  	  	  	  
<p>C_P_V5</p>	<p>C_F_V1 C_U_V1 C_UF_V1</p>	<p>C_P V5 C_F V1 + V_ <b>V5 1</b></p>	<p>C_P V5 C_F V1 + V_ <b>V5 1</b></p>	<p>C_P V5 C_F V1 + V_ <b>V5 3 1</b></p>	<p>C_P V5 C_F V1 + V_ <b>V5 2 1</b></p>
		  	  	  	  
		<p>C_P V5 C_F V1 + V_ <b>V5 2</b></p>	<p>C_P V5 C_F V1 + V_ <b>V5 2</b></p>	<p>C_P V5 C_F V1 + V_ <b>V5 3 2</b></p>	<p>C_P V5 C_F V1 + V_ <b>V5 2 2</b></p>

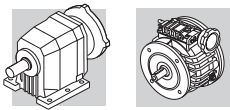

(E15)

**V6**

**V3**

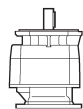
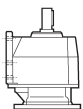

C\_P\_V6

C\_F\_V3  
C\_U\_V3  
C\_UF\_V3

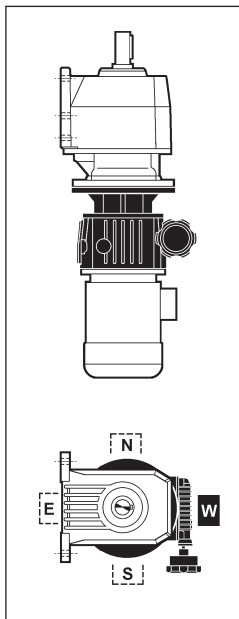

C\_P V6  
C\_F V3 + V\_ **V6 1**

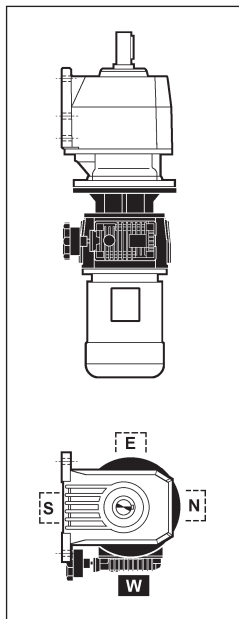

C\_P V6  
C\_F V3 + V\_ **V61 1**

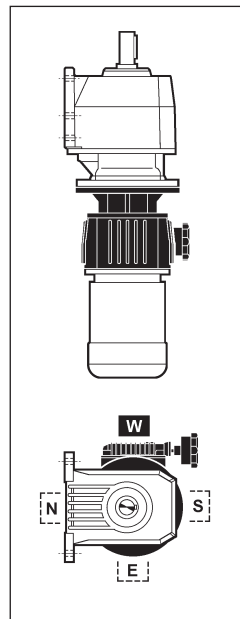

C\_P V6  
C\_F V3 + V\_ **V63 1**

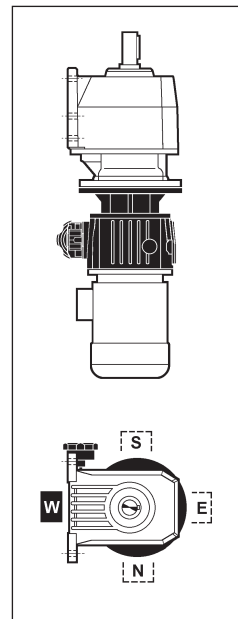

C\_P V6  
C\_F B5 + V\_ **V62 1**

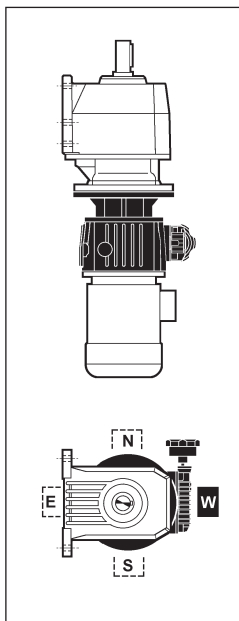

C\_P V6  
C\_F V3 + V\_ **V6 2**

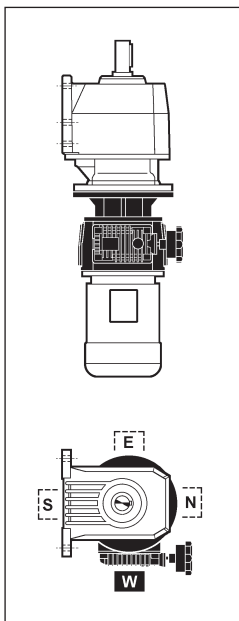

C\_P V6  
C\_F V3 + V\_ **V61 2**

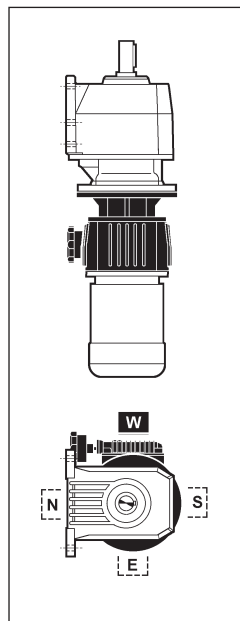



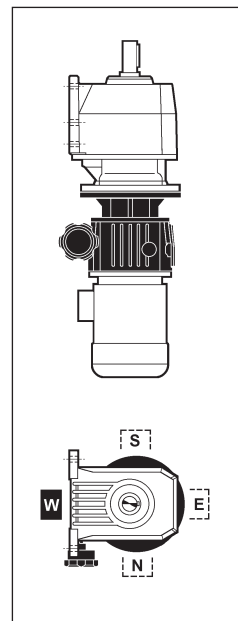

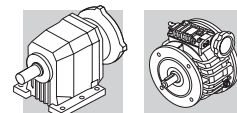

C\_P V6  
C\_F V3 + V\_ **V63 2**



C\_P V6  
C\_F V3 + V\_ **V62 2**



## 0.12 kW





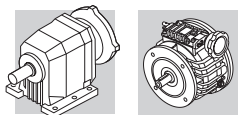

$n_2$ min <sup>-1</sup>	$n_2'$ min <sup>-1</sup>	$M_2$ Nm	$M_2'$ Nm	S	S'	i	R <sub>n2</sub> N					IEC 	
2.0	0.41	388	1024	1.5	0.6	304.2	7000	C414_304.2	V025 P63	V 0.25 C V 0.25 F	P63	BN63B6	192-193
2.6	0.54	296	782	1.5	0.6	232.3	6500	C354_232.3	V025 P63	V 0.25 C V 0.25 F	P63	BN63B6	190-191
3.7	0.77	211	557	2.1	0.8	162.0	6500	C353_162.0	— P63	— V 0.25 F	P63	BN63B6	190-191
4.9	1.0	159	421	1.9	0.7	122.4	5500	C313_122.4	V025 P63	V 0.25 C V 0.25 F	P63	BN63B6	188-189
5.8	1.2	134	356	2.2	0.8	103.3	5500	C313_103.3	V025 P63	V 0.25 C V 0.25 F	P63	BN63B6	188-189
7.3	1.5	108	284	2.8	1.1	82.6	5500	C313_82.6	V025 P63	V 0.25 C V 0.25 F	P63	BN63B6	188-189
9.5	2.0	84	223	1.6	0.6	63.3	5000	C212_63.3	V025 P63	V 0.25 C V 0.25 F	P63	BN63B6	186-187
11.0	2.3	73	192	2.2	0.9	54.7	5000	C212_54.7	V025 P63	V 0.25 C V 0.25 F	P63	BN63B6	186-187
13.9	2.9	58	152	3.3	1.2	43.3	5000	C212_43.3	V025 P63	V 0.25 C V 0.25 F	P63	BN63B6	186-187
16.3	3.4	49	130	1.8	0.7	37.0	2000	C112_37.0	V025 P63	V 0.25 C V 0.25 F	P63	BN63B6	184-185
16.4	3.4	49	129	4.1	1.5	36.8	5000	C212_36.8	V025 P63	V 0.25 C V 0.25 F	P63	BN63B6	186-187
18.4	3.8	44	115	2.1	0.8	32.8	2000	C112_32.8	V025 P63	V 0.25 C V 0.25 F	P63	BN63B6	184-185
20.4	4.2	39	104	5.1	1.9	29.6	5000	C212_29.6	V025 P63	V 0.25 C V 0.25 F	P63	BN63B6	186-187
20.5	4.2	39	104	2.5	1.0	29.5	2000	C112_29.5	V025 P63	V 0.25 C V 0.25 F	P63	BN63B6	184-185
23.8	4.9	34	89	2.6	1.0	25.4	2000	C112_25.4	V025 P63	V 0.25 C V 0.25 F	P63	BN63B6	184-185
26.4	5.5	31	81	3.3	1.2	22.9	2000	C112_22.9	V025 P63	V 0.25 C V 0.25 F	P63	BN63B6	184-185
29.3	6.1	27	72	3.2	1.2	20.6	2000	C112_20.6	V025 P63	V 0.25 C V 0.25 F	P63	BN63B6	184-185
35	7.3	23	60	3.8	1.5	17.2	2000	C112_17.2	V025 P63	V 0.25 C V 0.25 F	P63	BN63B6	184-185
39	8.1	21	54	4.2	1.8	15.5	2000	C112_15.5	V025 P63	V 0.25 C V 0.25 F	P63	BN63B6	184-185
45	9.3	18	47	4.5	1.9	13.4	2000	C112_13.4	V025 P63	V 0.25 C V 0.25 F	P63	BN63B6	184-185
60	12.4	13	36	5.4	2.5	10.1	2000	C112_10.1	V025 P63	V 0.25 C V 0.25 F	P63	BN63B6	184-185
79	16.4	10	27	6.4	3.0	7.6	2000	C112_7.6	V025 P63	V 0.25 C V 0.25 F	P63	BN63B6	184-185
97	20.2	8	22	7.4	3.2	6.2	2000	C112_6.2	V025 P63	V 0.25 C V 0.25 F	P63	BN63B6	184-185
123	25.5	7	17	8.4	3.9	4.9	2000	C112_4.9	V025 P63	V 0.25 C V 0.25 F	P63	BN63B6	184-185

## 0.18 kW

2.5	0.52	437	873	1.4	0.7	239.9	7000	C414_239.9	V025 P63	V 0.25 C V 0.25 F	P63	BN71A6R	192-193
3.5	0.72	359	957	1.7	0.6	263.0	7000	C414_263.0	V025 P63	V 0.25 C V 0.25 F	P63	BN63B4	192-193
3.8	0.79	327	873	1.8	0.7	239.9	7000	C414_239.9	V025 P63	V 0.25 C V 0.25 F	P63	BN63B4	192-193
4.4	0.92	288	768	1.6	0.6	206.4	6500	C353_206.4	— P63	— V 0.25 F	P63	BN63B4	190-191
5.8	1.2	192	384	1.6	0.8	103.3	5500	C313_103.3	V025 P63	V 0.25 C V 0.25 F	P63	BN71A6R	188-189







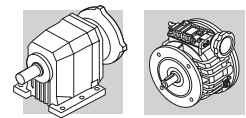

## 0.18 kW

$n_2$ min <sup>-1</sup>	$n_2'$ min <sup>-1</sup>	M <sub>2</sub> Nm	M <sub>2'</sub> Nm	S	S'	i	R <sub>n2</sub> N						
6.5	1.3	173	346	1.7	0.9	93.0	5500	C313_93.0	V025 P63	V 0.25 C V 0.25 F	P63	BN71A6R	188-189
7.1	1.5	178	474	2.5	1.0	127.3	6500	C353_127.3	— P63	— V 0.25 F	P63	BN63B4	190-191
7.3	1.5	154	307	2.0	1.0	82.6	5500	C313_82.6	V025 P63	V 0.25 C V 0.25 F	P63	BN71A6R	188-189
8.2	1.7	156	415	2.9	1.1	111.5	6500	C353_111.5	— P63	— V 0.25 F	P63	BN63B4	190-191
8.8	1.8	144	384	2.1	0.8	103.3	5500	C313_103.3	V025 P63	V 0.25 C V 0.25 F	P63	BN63B4	188-189
9.0	1.9	142	378	3.2	1.2	101.6	6500	C353_101.6	— P63	— V 0.25 F	P63	BN63B4	190-191
9.0	1.9	127	254	1.7	0.9	66.8	5500	C312_66.8	— P63	— V 0.25 F	P63	BN71A6R	188-189
11.0	2.3	115	307	2.6	1.0	82.6	5500	C313_82.6	V025 P63	V 0.25 C V 0.25 F	P63	BN63B4	188-189
11.5	2.4	100	199	3.0	1.5	52.4	5500	C312_52.4	— P63	— V 0.25 F	P63	BN71A6R	188-189
13.3	2.8	86	172	3.5	1.7	45.3	5500	C312_45.3	— P63	— V 0.25 F	P63	BN71A6R	188-189
13.6	2.8	95	254	2.3	0.9	66.8	5500	C312_66.8	— P63	— V 0.25 F	P63	BN63B4	188-189
13.9	2.9	82	165	2.3	1.2	43.3	5000	C212_43.3	V025 P63	V 0.25 C V 0.25 F	P63	BN71A6R	186-187
16.4	3.4	70	140	2.9	1.4	36.8	5000	C212_36.8	V025 P63	V 0.25 C V 0.25 F	P63	BN71A6R	186-187
17.4	3.6	75	199	4.0	1.5	52.4	5500	C312_52.4	— P63	— V 0.25 F	P63	BN63B4	188-189
20.1	4.2	65	172	4.6	1.7	45.3	5500	C312_45.3	— P63	— V 0.25 F	P63	BN63B4	188-189
20.4	4.2	56	113	3.6	1.8	29.6	5000	C212_29.6	V025 P63	V 0.25 C V 0.25 F	P63	BN71A6R	186-187
21.0	4.4	62	165	3.1	1.2	43.3	5000	C212_43.3	V025 P63	V 0.25 C V 0.25 F	P63	BN63B4	186-187
23.8	4.9	48	97	1.8	0.9	25.4	2000	C112_25.4	V025 P63	V 0.25 C V 0.25 F	P63	BN71A6R	184-185
24.7	5.2	52	140	3.8	1.4	36.8	5000	C212_36.8	V025 P63	V 0.25 C V 0.25 F	P63	BN63B4	186-187
24.9	5.1	46	92	4.3	2.2	24.3	5000	C212_24.3	V025 P63	V 0.25 C V 0.25 F	P63	BN71A6R	186-187
27.7	5.8	47	125	1.9	0.7	32.8	2000	C112_32.8	V025 P63	V 0.25 C V 0.25 F	P63	BN63B4	184-185
29.3	6.1	39	78	2.3	1.1	20.6	2000	C112_20.6	V025 P63	V 0.25 C V 0.25 F	P63	BN71A6R	184-185
30	6.3	38	76	5.3	2.6	20.0	5000	C212_20.0	V025 P63	V 0.25 C V 0.25 F	P63	BN71A6R	186-187
31	6.4	42	112	2.4	0.9	29.5	2000	C112_29.5	V025 P63	V 0.25 C V 0.25 F	P63	BN63B4	184-185
35	7.3	33	65	2.7	1.4	17.2	2000	C112_17.2	V025 P63	V 0.25 C V 0.25 F	P63	BN71A6R	184-185
36	7.5	36	97	2.5	0.9	25.4	2000	C112_25.4	V025 P63	V 0.25 C V 0.25 F	P63	BN63B4	184-185
37	7.8	35	92	5.8	2.2	24.3	4760	C212_24.3	V025 P63	V 0.25 C V 0.25 F	P63	BN63B4	186-187
44	9.2	29	78	3.0	1.1	20.6	2000	C112_20.6	V025 P63	V 0.25 C V 0.25 F	P63	BN63B4	184-185
45	9.3	25	51	3.2	1.8	13.4	2000	C112_13.4	V025 P63	V 0.25 C V 0.25 F	P63	BN71A6R	184-185
53	11.0	25	65	3.6	1.4	17.2	2000	C112_17.2	V025 P63	V 0.25 C V 0.25 F	P63	BN63B4	184-185
58	12.0	23	60	8.9	3.3	15.8	4160	C212_15.8	V025 P63	V 0.25 C V 0.25 F	P63	BN63B4	186-187
60	12.4	19	38	3.8	2.3	10.1	2000	C112_10.1	V025 P63	V 0.25 C V 0.25 F	P63	BN71A6R	184-185
68	14.2	19	51	4.2	1.8	13.4	2000	C112_13.4	V025 P63	V 0.25 C V 0.25 F	P63	BN63B4	184-185
79	16.4	14	29	4.5	2.7	7.6	2000	C112_7.6	V025 P63	V 0.25 C V 0.25 F	P63	BN71A6R	184-185
90	18.8	14	38	5.0	2.3	10.1	2000	C112_10.1	V025 P63	V 0.25 C V 0.25 F	P63	BN63B4	184-185



## 0.18 kW





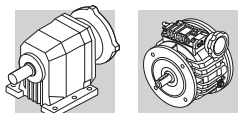

$n_2$ min <sup>-1</sup>	$n_2'$ min <sup>-1</sup>	M <sub>2</sub> Nm	M <sub>2'</sub> Nm	S	S'	i	R <sub>n2</sub> N					IEC 	
97	20.2	12	24	5.2	3.0	6.2	2000	C112_6.2	V025 P63	V 0.25 C V 0.25 F	P63	BN71A6R	184-185
120	25.0	11	29	6.0	2.7	7.6	2000	C112_7.6	V025 P63	V 0.25 C V 0.25 F	P63	BN63B4	184-185
123	25.5	9	19	5.9	3.6	4.9	2000	C112_4.9	V025 P63	V 0.25 C V 0.25 F	P63	BN71A6R	184-185
147	31	9	24	6.9	3.0	6.2	1950	C112_6.2	V025 P63	V 0.25 C V 0.25 F	P63	BN63B4	184-185
186	39	7	19	7.9	3.6	4.9	1800	C112_4.9	V025 P63	V 0.25 C V 0.25 F	P63	BN63B4	184-185

## 0.25 kW

2.2	0.41	841	2102	1.9	0.8	462.0	7000	C614_462.0	V05 P71	V 0.5 C V 0.5 F	P71	BN71A4	196-197
3.0	0.56	615	1537	2.6	1.0	337.7	16000	C614_337.7	V05 P71	V 0.5 C V 0.5 F	P71	BN71A4	196-197
3.8	0.72	480	1200	2.1	0.8	263.8	10000	C514_263.8	V05 P71	V 0.5 C V 0.5 F	P71	BN71A4	194-195
4.2	0.79	438	1096	2.3	0.9	240.9	10000	C514_240.9	V05 P71	V 0.5 C V 0.5 F	P71	BN71A4	194-195
4.2	0.80	434	1084	3.7	1.5	238.3	16000	C614_238.3	V05 P71	V 0.5 C V 0.5 F	P71	BN71A4	196-197
5.2	1.0	355	887	1.7	0.7	190.8	7000	C413_190.8	V05 P71	V 0.5 C V 0.5 F	P71	BN71A4	192-193
6.1	1.2	305	763	2.0	0.8	164.1	7000	C413_164.1	V05 P71	V 0.5 C V 0.5 F	P71	BN71A4	192-193
6.2	1.2	301	753	1.5	0.6	162.0	6500	C353_162.0	V05 P71	V 0.5 C V 0.5 F	P71	BN71A4	190-191
6.8	1.3	275	686	1.6	0.7	147.6	6500	C353_147.6	V05 P71	V 0.5 C V 0.5 F	P71	BN71A4	190-191
7.1	1.5	213	474	2.1	1.0	127.3	6500	C353_127.3	— P63	— V 0.25 F	P63	BN63C4	190-191
7.2	1.4	260	650	1.7	0.7	139.8	6500	C353_139.8	V05 P71	V 0.5 C V 0.5 F	P71	BN71A4	190-191
8.2	1.7	187	415	2.4	1.1	111.5	6500	C353_111.5	— P63	— V 0.25 F	P63	BN63C4	190-191
8.3	1.6	224	561	2.7	1.1	120.6	7000	C413_120.6	V05 P71	V 0.5 C V 0.5 F	P71	BN71A4	192-193
9.0	1.9	170	378	2.6	1.2	101.6	6500	C353_101.6	— P63	— V 0.25 F	P63	BN63C4	190-191
9.0	1.7	207	518	2.2	0.9	111.5	6500	C353_111.5	V05 P71	V 0.5 C V 0.5 F	P71	BN71A4	190-191
9.9	2.1	154	342	2.9	1.3	91.9	6500	C353_91.9	— P63	— V 0.25 F	P63	BN63C4	190-191
10.9	2.1	171	427	2.6	1.1	91.9	6500	C353_91.9	V05 P71	V 0.5 C V 0.5 F	P71	BN71A4	190-191
11.0	2.3	138	307	2.2	1.0	82.6	5500	C313_82.6	V025 P63	V 0.25 C V 0.25 F	P63	BN63C4	188-189
11.7	2.4	130	289	3.5	1.6	77.6	6500	C353_77.6	— P63	— V 0.25 F	P63	BN63C4	190-191
11.9	2.3	156	390	2.9	1.2	83.8	6500	C353_83.8	V05 P71	V 0.5 C V 0.5 F	P71	BN71A4	190-191
14.1	2.7	132	329	3.4	1.4	70.7	6500	C353_70.7	V05 P71	V 0.5 C V 0.5 F	P71	BN71A4	190-191
14.7	3.1	104	231	4.3	2.0	62.0	6500	C353_62.0	— P63	— V 0.25 F	P63	BN63C4	190-191
16.6	3.5	94	208	1.7	0.8	54.7	5000	C212_54.7	V025 P63	V 0.25 C V 0.25 F	P63	BN63C4	186-187
17.4	3.6	90	199	3.3	1.5	52.4	5500	C312_52.4	— P63	— V 0.25 F	P63	BN63C4	188-189
17.7	3.4	105	263	4.3	1.7	56.5	6500	C353_56.5	V05 P71	V 0.5 C V 0.5 F	P71	BN71A4	190-191
19.1	3.6	100	249	3.0	1.2	52.4	5500	C312_52.4	V05 P71	V 0.5 C V 0.5 F	P71	BN71A4	188-189
20.1	4.2	78	172	3.9	1.7	45.3	5500	C312_45.3	— P63	— V 0.25 F	P63	BN63C4	188-189
21.0	4.4	74	165	2.6	1.2	43.3	5000	C212_43.3	V025 P63	V 0.25 C V 0.25 F	P63	BN63C4	186-187





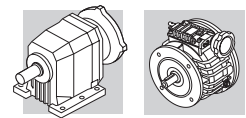

## 0.25 kW

$n_2$ min <sup>-1</sup>	$n_2'$ min <sup>-1</sup>	$M_2$ Nm	$M_2'$ Nm	S	S'	i	R <sub>n2</sub> N						
21.2	4.0	90	224	3.3	1.3	47.2	5500	C312_47.2	V05 P71	V 0.5 C V 0.5 F	P71	BN71A4	188-189
22.1	4.2	86	215	3.5	1.4	45.3	5500	C312_45.3	V05 P71	V 0.5 C V 0.5 F	P71	BN71A4	188-189
24.7	5.2	63	140	3.2	1.4	36.8	5000	C212_36.8	V025 P63	V 0.25 C V 0.25 F	P63	BN63C4	186-187
26.4	5.0	72	191	4.2	1.6	25.1	5500	C312_25.1	V05 P71	V 0.5 C V 0.5 F	P71	BN71B6	188-189
27.2	5.7	57	127	1.8	0.8	33.4	2000	C112_33.4	V025 P63	V 0.25 C V 0.25 F	P63	BN63C4	184-185
27.2	5.2	70	175	2.9	1.1	36.8	5000	C212_36.8	V05 P71	V 0.5 C V 0.5 F	P71	BN71A4	186-187
30	5.7	63	157	3.2	1.3	33.1	4910	C212_33.1	V05 P71	V 0.5 C V 0.5 F	P71	BN71A4	186-187
31	6.4	50	112	2.0	0.9	29.5	2000	C112_29.5	V025 P63	V 0.25 C V 0.25 F	P63	BN63C4	184-185
31	6.4	51	112	4.0	1.8	29.6	4970	C212_29.6	V025 P63	V 0.25 C V 0.25 F	P63	BN63C4	186-187
34	6.4	56	140	1.8	0.7	29.5	2000	C112_29.5	V05 P71	V 0.5 C V 0.5 F	P71	BN71A4	184-185
34	6.4	56	141	3.6	1.4	29.6	4770	C212_29.6	V05 P71	V 0.5 C V 0.5 F	P71	BN71A4	186-187
37	7.1	51	127	3.9	1.6	26.7	4620	C212_26.7	V05 P71	V 0.5 C V 0.5 F	P71	BN71A4	186-187
37	7.8	42	92	4.8	2.2	24.3	4690	C212_24.3	V025 P63	V 0.25 C V 0.25 F	P63	BN63C4	186-187
38	8.0	45	118	1.9	0.8	47.6	2000	C112_47.6	V025 P63	V 0.25 C V 0.25 F	P63	BN63B2	184-185
40	8.3	39	87	2.5	1.1	22.9	2000	C112_22.9	V025 P63	V 0.25 C V 0.25 F	P63	BN63C4	184-185
41	7.8	46	115	4.3	1.7	24.3	4500	C212_24.3	V05 P71	V 0.5 C V 0.5 F	P71	BN71A4	186-187
42	8.9	41	106	2.1	0.9	42.9	2000	C112_42.9	V025 P63	V 0.25 C V 0.25 F	P63	BN63B2	184-185
42	8.8	41	107	4.5	1.8	43.3	4500	C212_43.3	V025 P63	V 0.25 C V 0.25 F	P63	BN63B2	186-187
44	9.2	35	78	2.5	1.1	20.6	2000	C112_20.6	V025 P63	V 0.25 C V 0.25 F	P63	BN63C4	184-185
49	10.3	35	91	2.2	1.0	37.0	2000	C112_37.0	V025 P63	V 0.25 C V 0.25 F	P63	BN63B2	184-185
50	9.5	38	95	5.3	2.1	20.0	4250	C212_20.0	V05 P71	V 0.5 C V 0.5 F	P71	BN71A4	186-187
53	11.0	29	65	3.0	1.4	17.2	2000	C112_17.2	V025 P63	V 0.25 C V 0.25 F	P63	BN63C4	184-185
55	11.6	31	81	2.4	1.1	32.8	2000	C112_32.8	V025 P63	V 0.25 C V 0.25 F	P63	BN63B2	184-185
58	11.0	33	82	2.7	1.1	17.2	2000	C112_17.2	V05 P71	V 0.5 C V 0.5 F	P71	BN71A4	184-185
62	12.9	28	73	2.6	1.4	29.5	2000	C112_29.5	V025 P63	V 0.25 C V 0.25 F	P63	BN63B2	184-185
65	12.3	29	74	2.9	1.3	15.5	2000	C112_15.5	V05 P71	V 0.5 C V 0.5 F	P71	BN71A4	184-185
68	14.2	23	51	3.5	1.8	13.4	2000	C112_13.4	V025 P63	V 0.25 C V 0.25 F	P63	BN63C4	184-185
72	15.0	24	63	2.9	1.4	25.4	2000	C112_25.4	V025 P63	V 0.25 C V 0.25 F	P63	BN63B2	184-185
75	15.7	21	46	3.8	2.1	12.1	2000	C112_12.1	V025 P63	V 0.25 C V 0.25 F	P63	BN63C4	184-185
79	16.6	22	57	3.1	1.8	22.9	2000	C112_22.9	V025 P63	V 0.25 C V 0.25 F	P63	BN63B2	184-185
83	15.7	23	57	3.4	1.7	12.1	2000	C112_12.1	V05 P71	V 0.5 C V 0.5 F	P71	BN71A4	184-185
87	16.4	22	58	3.0	1.4	7.6	2000	C112_7.6	V05 P71	V 0.5 C V 0.5 F	P71	BN71B6	184-185
88	18.4	20	51	3.3	1.7	20.6	2000	C112_20.6	V025 P63	V 0.25 C V 0.25 F	P63	BN63B2	184-185
90	18.8	17	38	4.2	2.3	10.1	2000	C112_10.1	V025 P63	V 0.25 C V 0.25 F	P63	BN63C4	184-185
99	18.8	19	48	3.8	1.8	10.1	2000	C112_10.1	V05 P71	V 0.5 C V 0.5 F	P71	BN71A4	184-185
106	22.1	16	42	3.7	2.1	17.2	2000	C112_17.2	V025 P63	V 0.25 C V 0.25 F	P63	BN63B2	184-185

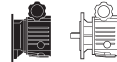

## 0.25 kW



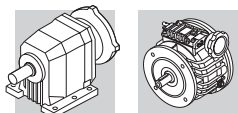

$n_2$ min <sup>-1</sup>	$n_2'$ min <sup>-1</sup>	M <sub>2</sub> Nm	M <sub>2'</sub> Nm	S	S'	i	R <sub>n2</sub> N						
109	20.5	17	46	6.3	2.5	6.1	3330	C212_6.1	V05 P71	V 0.5 C V 0.5 F	P71	BN71B6	186-187
120	25.0	13	29	5.0	2.7	7.6	2000	C112_7.6	V025 P63	V 0.25 C V 0.25 F	P63	BN63C4	184-185
132	25.0	14	36	4.5	2.2	7.6	2000	C112_7.6	V05 P71	V 0.5 C V 0.5 F	P71	BN71A4	184-185
136	28.4	13	33	4.3	2.7	13.4	2000	C112_13.4	V025 P63	V 0.25 C V 0.25 F	P63	BN63B2	184-185
138	26.0	14	36	7.7	2.9	4.8	3080	C212_4.8	V05 P71	V 0.5 C V 0.5 F	P71	BN71B6	186-187
147	31	11	24	5.8	3.0	6.2	1940	C112_6.2	V025 P63	V 0.25 C V 0.25 F	P63	BN63C4	184-185
161	31	12	29	5.2	2.4	6.2	1870	C112_6.2	V05 P71	V 0.5 C V 0.5 F	P71	BN71A4	184-185
164	31	12	29	9.5	4.0	6.1	2900	C212_6.1	V05 P71	V 0.5 C V 0.5 F	P71	BN71A4	186-187
180	38	10	25	5.1	3.5	10.1	1830	C112_10.1	V025 P63	V 0.25 C V 0.25 F	P63	BN63B2	184-185
186	39	8	19	6.6	3.6	4.9	1790	C112_4.9	V025 P63	V 0.25 C V 0.25 F	P63	BN63C4	184-185
204	39	9	23	5.9	2.9	4.9	1730	C112_4.9	V05 P71	V 0.5 C V 0.5 F	P71	BN71A4	184-185
239	50	7	19	6.2	4.2	7.6	1680	C112_7.6	V025 P63	V 0.25 C V 0.25 F	P63	BN63B2	184-185
294	61	6	15	7.1	4.6	6.2	1550	C112_6.2	V025 P63	V 0.25 C V 0.25 F	P63	BN63B2	184-185
371	78	5	12	8.2	5.5	4.9	1430	C112_4.9	V025 P63	V 0.25 C V 0.25 F	P63	BN63B2	184-185

## 0.37 kW

3.6	0.69	752	2004	2.1	0.8	275.3	16000	C614_275.3	V05 P71	V 0.5 C V 0.5 F	P71	BN71B4	196-197
4.6	0.87	594	1583	2.7	1.0	217.4	16000	C614_217.4	V05 P71	V 0.5 C V 0.5 F	P71	BN71B4	196-197
5.5	1.0	449	897	1.3	0.7	120.6	7000	C413_120.6	V05 P71	V 0.5 C V 0.5 F	P71	BN71C6	192-193
6.5	1.2	381	761	1.6	0.8	102.3	7000	C413_102.3	V05 P71	V 0.5 C V 0.5 F	P71	BN71C6	192-193
8.3	1.6	336	897	1.8	0.7	120.6	7000	C413_120.6	V05 P71	V 0.5 C V 0.5 F	P71	BN71B4	192-193
9.1	1.7	307	819	2.0	0.7	110.1	7000	C413_110.1	V05 P71	V 0.5 C V 0.5 F	P71	BN71B4	192-193
9.8	1.9	285	761	2.1	0.8	102.3	7000	C413_102.3	V05 P71	V 0.5 C V 0.5 F	P71	BN71B4	192-193
11.9	2.3	234	623	1.9	0.7	83.8	6500	C353_83.8	V05 P71	V 0.5 C V 0.5 F	P71	BN71B4	190-191
12.3	2.3	227	606	2.6	1.0	81.5	7000	C413_81.5	V05 P71	V 0.5 C V 0.5 F	P71	BN71B4	192-193
13.4	2.6	208	554	2.9	1.1	74.4	7000	C413_74.4	V05 P71	V 0.5 C V 0.5 F	P71	BN71B4	192-193
14.6	2.8	172	344	1.7	0.9	45.3	5500	C312_45.3	V05 P71	V 0.5 C V 0.5 F	P71	BN71C6	188-189
15.6	3.0	179	478	3.3	1.3	64.3	7000	C413_64.3	V05 P71	V 0.5 C V 0.5 F	P71	BN71B4	192-193
17.7	3.4	158	420	2.9	1.1	56.5	6500	C353_56.5	V05 P71	V 0.5 C V 0.5 F	P71	BN71B4	190-191
19.4	3.7	144	383	4.2	1.6	51.5	7000	C413_51.5	V05 P71	V 0.5 C V 0.5 F	P71	BN71B4	192-193
22.1	4.2	129	344	2.3	0.9	45.3	5500	C312_45.3	V05 P71	V 0.5 C V 0.5 F	P71	BN71B4	188-189
22.3	4.2	128	340	3.9	1.5	44.8	7000	C412_44.8	V05 P71	V 0.5 C V 0.5 F	P71	BN71B4	192-193
27.0	5.1	106	282	4.7	1.8	37.1	7000	C412_37.1	V05 P71	V 0.5 C V 0.5 F	P71	BN71B4	192-193



## 0.37 kW

$n_2$ min <sup>-1</sup>	$n_2'$ min <sup>-1</sup>	M <sub>2</sub> Nm	M <sub>2'</sub> Nm	S	S'	i	R <sub>n2</sub> N						
27.2	5.7	95	254	2.2	0.9	66.8	5500	C312_66.8	—	—	P63	BN63C2	188-189
27.7	5.3	103	274	2.9	1.1	36.1	5500	C312_36.1	V05 P71	V 0.5 C V 0.5 F	P71	BN71B4	188-189
32	6.1	89	239	5.6	2.1	31.4	7000	C412_31.4	V05 P71	V 0.5 C V 0.5 F	P71	BN71B4	192-193
33	6.3	76	152	2.6	1.3	20.0	4670	C212_20.0	V05 P71	V 0.5 C V 0.5 F	P71	BN71C6	186-187
34	6.4	84	225	2.4	0.9	29.6	4580	C212_29.6	V05 P71	V 0.5 C V 0.5 F	P71	BN71B4	186-187
40	7.6	71	190	7.0	2.6	25.0	7000	C412_25.0	V05 P71	V 0.5 C V 0.5 F	P71	BN71B4	192-193
41	7.8	69	185	2.9	1.1	24.3	4350	C212_24.3	V05 P71	V 0.5 C V 0.5 F	P71	BN71B4	186-187
41	8.7	61	163	7.0	2.8	43.9	6500	C353_43.9	—	—	P63	BN63C2	190-191
42	8.8	62	165	3.0	1.2	43.3	4370	C212_43.3	V025 P63	V 0.25 C V 0.25 F	P63	BN63C2	186-187
50	9.5	57	152	3.5	1.3	20.0	4130	C212_20.0	V05 P71	V 0.5 C V 0.5 F	P71	BN71B4	186-187
50	10.5	51	137	5.4	2.2	36.1	5500	C312_36.1	—	—	P63	BN63C2	188-189
61	12.8	42	112	4.1	1.8	29.6	3930	C212_29.6	V025 P63	V 0.25 C V 0.25 F	P63	BN63C2	186-187
63	12.0	45	120	4.4	1.7	15.8	3870	C212_15.8	V05 P71	V 0.5 C V 0.5 F	P71	BN71B4	186-187
66	12.4	38	77	1.9	1.1	10.1	2000	C112_10.1	V05 P71	V 0.5 C V 0.5 F	P71	BN71C6	184-185
68	12.9	37	74	4.6	2.7	9.7	3810	C212_9.7	V05 P71	V 0.5 C V 0.5 F	P71	BN71C6	186-187
75	14.2	38	102	2.1	0.9	13.4	2000	C112_13.4	V05 P71	V 0.5 C V 0.5 F	P71	BN71B4	184-185
81	15.3	35	94	5.2	2.1	12.4	3610	C212_12.4	V05 P71	V 0.5 C V 0.5 F	P71	BN71B4	186-187
83	15.7	34	92	2.3	1.0	12.1	2000	C112_12.1	V05 P71	V 0.5 C V 0.5 F	P71	BN71B4	184-185
88	18.4	29	78	2.2	1.1	20.6	2000	C112_20.6	V025 P63	V 0.25 C V 0.25 F	P63	BN63C2	184-185
91	19.0	29	76	5.3	2.6	20.0	3500	C212_20.0	V025 P63	V 0.25 C V 0.25 F	P63	BN63C2	186-187
99	18.8	29	77	2.5	1.1	10.1	2000	C112_10.1	V05 P71	V 0.5 C V 0.5 F	P71	BN71B4	184-185
103	19.6	28	74	6.1	2.7	9.7	3350	C212_9.7	V05 P71	V 0.5 C V 0.5 F	P71	BN71B4	186-187
106	22.1	25	65	2.4	1.4	17.2	2000	C112_17.2	V025 P63	V 0.25 C V 0.25 F	P63	BN63C2	184-185
109	20.5	23	46	4.7	2.5	6.1	3300	C212_6.1	V05 P71	V 0.5 C V 0.5 F	P71	BN71C6	186-187
117	24.5	22	59	2.6	1.7	15.5	2000	C112_15.5	V05 P63	V 0.25 C V 0.25 F	P63	BN63C2	184-185
132	25.0	22	58	3.0	1.4	7.6	1970	C112_7.6	V05 P71	V 0.5 C V 0.5 F	P71	BN71B4	184-185
136	28.4	19	51	2.9	1.8	13.4	1960	C112_13.4	V025 P63	V 0.25 C V 0.25 F	P63	BN63C2	184-185
161	31	18	47	3.5	1.5	6.2	1830	C112_6.2	V05 P71	V 0.5 C V 0.5 F	P71	BN71B4	184-185
164	31	17	46	6.3	2.5	6.1	2870	C212_6.1	V05 P71	V 0.5 C V 0.5 F	P71	BN71B4	186-187
180	38	14	38	3.4	2.3	10.1	1800	C112_10.1	V025 P63	V 0.25 C V 0.25 F	P63	BN63C2	184-185
204	39	14	37	3.9	1.8	4.9	1700	C112_4.9	V05 P71	V 0.5 C V 0.5 F	P71	BN71B4	184-185
239	50	11	29	4.2	2.7	7.6	1660	C112_7.6	V025 P63	V 0.25 C V 0.25 F	P63	BN63C2	184-185
270	51	11	28	4.6	2.1	3.7	1560	C112_3.7	V05 P71	V 0.5 C V 0.5 F	P71	BN71B4	184-185
294	61	9	24	4.8	3.0	6.2	1530	C112_6.2	V025 P63	V 0.25 C V 0.25 F	P63	BN63C2	184-185
371	78	7	19	5.4	3.6	4.9	1420	C112_4.9	V025 P63	V 0.25 C V 0.25 F	P63	BN63C2	184-185



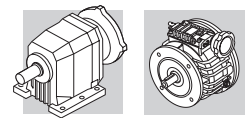

## 0.37 kW





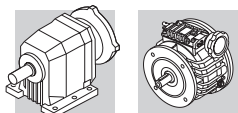

$n_2$ min <sup>-1</sup>	$n_2'$ min <sup>-1</sup>	$M_2$ Nm	$M_2'$ Nm	S	S'	i	R <sub>n2</sub> N					IEC	
492	103	5	14	6.4	4.3	3.7	1300	C112_3.7	V025 P63	V 0.25 C V 0.25 F	P63	BN63C2	184-185
650	136	4	11	7.5	5.0	2.8	1190		V025 P63	V 0.25 C V 0.25 F			

## 0.55 kW

3.4	0.60	1083	2888	2.1	0.8	194.1	25000	C703_194.1	— P80	— V 1 F	P80	BN80B6	198-199
3.6	0.69	1127	2004	1.4	0.8	275.3	16000	C614_275.3	V05 P71	V 0.5 C V 0.5 F	P80	BN80A4	196-197
3.7	0.70	1000	2666	2.3	0.9	179.2	25000	C703_179.2	— P80	— V 1 F	P80	BN80B6	198-199
4.2	0.80	976	1735	1.6	0.9	238.3	16000	C614_238.3	V05 P71	V 0.5 C V 0.5 F	P80	BN80A4	196-197
4.2	0.80	1001	2671	2.3	0.9	239.3	25000	C703_239.3	— P80	— V 1 F	P80	BN80A4	198-199
4.5	0.90	924	2465	2.4	0.9	220.9	25000	C703_220.9	— P80	— V 1 F	P80	BN80A4	198-199
4.6	0.87	890	1583	1.8	1.0	217.4	16000	C614_217.4	V05 P71	V 0.5 C V 0.5 F	P80	BN80A4	196-197
4.8	0.90	767	2045	3.0	1.1	137.4	25000	C703_137.4	— P80	— V 1 F	P80	BN80B6	198-199
5.1	0.97	819	2185	2.0	0.7	195.8	16000	C613_195.8	— P80	— V 1 F	P80	BN80A4	196-197
5.2	1.0	812	2166	2.8	1.1	194.1	25000	C703_194.1	— P80	— V 1 F	P80	BN80A4	198-199
5.6	1.1	747	1993	2.1	0.8	178.6	16000	C613_178.6	— P80	— V 1 F	P80	BN80A4	196-197
5.6	1.1	750	2000	3.1	1.2	179.2	25000	C703_179.2	— P80	— V 1 F	P80	BN80A4	198-199
6.1	1.2	681	1817	3.4	1.3	162.8	25000	C703_162.8	— P80	— V 1 F	P80	BN80A4	198-199
6.4	1.2	578	1542	2.8	1.0	103.6	16000	C613_103.6	— P80	— V 1 F	P80	BN80B6	196-197
6.5	1.2	571	761	1.1	0.8	102.3	7000	C413_102.3	V05 P71	V 0.5 C V 0.5 F	P80	BN80B6	192-193
7.1	1.3	521	694	1.2	0.9	93.3	7000	C413_93.3	V05 P71	V 0.5 C V 0.5 F	P80	BN80B6	192-193
7.4	1.4	563	1502	1.8	0.7	134.6	10000	C513_134.6	— P80	— V 1 F	P80	BN80A4	194-195
7.8	1.5	536	1430	3.0	1.1	128.1	16000	C613_128.1	— P80	— V 1 F	P80	BN80A4	196-197
7.9	1.5	531	1415	4.3	1.6	126.8	25000	C703_126.8	— P80	— V 1 F	P80	BN80A4	198-199
8.0	1.5	463	1235	3.5	1.3	83.0	16000	C613_83.0	— P80	— V 1 F	P80	BN80B6	196-197
8.8	1.7	475	1268	2.1	0.8	113.6	10000	C513_113.6	— P80	— V 1 F	P80	BN80A4	194-195
8.8	1.7	475	1268	3.4	1.3	113.6	16000	C613_113.6	— P80	— V 1 F	P80	BN80A4	196-197
8.9	1.7	415	554	1.4	1.1	74.4	7000	C413_74.4	V05 P71	V 0.5 C V 0.5 F	P80	BN80B6	192-193
9.7	1.8	434	1156	3.7	1.4	103.6	16000	C613_103.6	— P80	— V 1 F	P80	BN80A4	196-197
9.8	1.9	426	1136	2.3	0.9	101.8	10000	C513_101.8	— P80	— V 1 F	P80	BN80A4	194-195
10.3	1.9	359	478	1.7	1.3	64.3	7000	C413_64.3	V05 P71	V 0.5 C V 0.5 F	P80	BN80B6	192-193
11.6	2.2	325	866	2.4	0.9	57.0	10000	C512_57.0	— P80	— V 1 F	P80	BN80B6	194-195
11.7	2.2	315	420	1.4	1.1	56.5	6500	C353_56.5	V05 P71	V 0.5 C V 0.5 F	P80	BN80B6	190-191
12.3	2.3	341	606	1.8	1.0	81.5	7000	C413_81.5	V05 P71	V 0.5 C V 0.5 F	P80	BN80A4	192-193







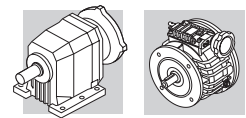

## 0.55 kW

$n_2$ min <sup>-1</sup>	$n_2'$ min <sup>-1</sup>	M <sub>2</sub> Nm	M <sub>2'</sub> Nm	S	S'	i	R <sub>n2</sub> N						
12.3	2.3	341	910	1.8	0.7	81.5	7000	C413_81.5	V1 P80	V 1 C V 1 F	P80	BN80A4	192-193
12.5	2.4	334	892	3.0	1.1	79.9	10000	C513_79.9	— P80	— V 1 F	P80	BN80A4	194-195
13.4	2.6	311	554	1.9	1.1	74.4	7000	C413_74.4	V05 P71	V 0.5 C V 0.5 F	P80	BN80A4	192-193
13.4	2.6	311	830	1.9	0.7	74.4	7000	C413_74.4	V1 P80	V 1 C V 1 F	P80	BN80A4	192-193
13.9	2.6	266	708	6.0	2.3	47.6	16000	C613_47.6	— P80	— V 1 F	P80	BN80B6	196-197
14.1	2.7	262	699	2.3	0.9	47.0	7000	C413_47.0	V1 P80	V 1 C V 1 F	P80	BN80B6	192-193
14.1	2.7	296	526	1.5	0.9	70.7	6500	C353_70.7	V05 P71	V 0.5 C V 0.5 F	P80	BN80A4	190-191
15.5	2.9	270	721	3.7	1.4	64.6	10000	C513_64.6	— P80	— V 1 F	P80	BN80A4	194-195
15.6	3.0	269	478	2.2	1.3	64.3	7000	C413_64.3	V05 P71	V 0.5 C V 0.5 F	P80	BN80A4	192-193
15.6	3.0	269	718	2.2	0.8	64.3	7000	C413_64.3	V1 P80	V 1 C V 1 F	P80	BN80A4	192-193
17.5	3.3	244	650	3.3	1.2	57.0	10000	C512_57.0	— P80	— V 1 F	P80	BN80A4	194-195
17.7	3.4	236	420	1.9	1.1	56.5	6500	C353_56.5	V05 P71	V 0.5 C V 0.5 F	P80	BN80A4	190-191
17.9	3.4	211	564	2.4	0.9	37.1	7000	C412_37.1	V1 P80	V 1 C V 1 F	P80	BN80B6	192-193
19.5	3.7	214	571	4.7	1.8	51.2	10000	C513_51.2	— P80	— V 1 F	P80	BN80A4	194-195
19.7	3.7	189	472	2.4	1.0	101.6	6500	C353_101.6	V05 P71	V 0.5 C V 0.5 F	P71	BN71B2	190-191
19.9	3.7	190	508	2.6	1.0	33.4	7000	C412_33.4	V1 P80	V 1 C V 1 F	P80	BN80B6	192-193
22.2	4.2	170	453	4.7	1.8	29.8	10000	C512_29.8	— P80	— V 1 F	P80	BN80B6	194-195
22.3	4.2	192	340	2.6	1.5	44.8	7000	C412_44.8	V05 P71	V 0.5 C V 0.5 F	P80	BN80A4	192-193
22.3	4.2	192	511	2.6	1.0	44.8	7000	C412_44.8	V1 P80	V 1 C V 1 F	P80	BN80A4	192-193
26.2	5.0	159	283	2.8	1.6	38.1	6500	C353_38.1	V05 P71	V 0.5 C V 0.5 F	P80	BN80A4	190-191
26.2	5.0	159	425	2.8	1.1	38.1	6500	C353_38.1	V1 P80	V 1 C V 1 F	P80	BN80A4	190-191
27.0	5.1	159	423	3.2	1.2	37.1	7000	C412_37.1	V1 P80	V 1 C V 1 F	P80	BN80A4	192-193
32	6.1	131	232	4.6	2.6	31.2	7000	C413_31.2	V05 P71	V 0.5 C V 0.5 F	P80	BN80A4	192-193
32	6.1	131	348	4.6	1.7	31.2	7000	C413_31.2	V1 P80	V 1 C V 1 F	P80	BN80A4	192-193
35	6.6	120	214	3.7	2.1	28.7	6500	C353_28.7	V05 P71	V 0.5 C V 0.5 F	P80	BN80A4	190-191
35	6.6	120	320	3.7	1.4	28.7	6500	C353_28.7	V1 P80	V 1 C V 1 F	P80	BN80A4	190-191
38	7.3	100	249	3.0	1.2	52.4	5500	C312_52.4	V05 P71	V 0.5 C V 0.5 F	P71	BN71B2	188-189
38	7.3	110	195	4.1	2.3	26.2	6500	C353_26.2	V05 P71	V 0.5 C V 0.5 F	P80	BN80A4	190-191
38	7.3	110	292	4.1	1.5	26.2	6500	C353_26.2	V1 P80	V 1 C V 1 F	P80	BN80A4	190-191
40	7.6	107	286	2.8	1.0	25.1	5500	C312_25.1	V1 P80	V 1 C V 1 F	P80	BN80A4	188-189
40	7.6	107	285	4.7	1.8	25.0	7000	C412_25.0	V1 P80	V 1 C V 1 F	P80	BN80A4	192-193
44	8.4	86	215	3.5	1.4	45.3	5500	C312_45.3	V05 P71	V 0.5 C V 0.5 F	P71	BN71B2	188-189
45	8.6	92	164	4.9	2.7	22.1	6500	C353_22.1	V05 P71	V 0.5 C V 0.5 F	P80	BN80A4	190-191
45	8.6	92	247	4.9	1.8	22.1	6500	C353_22.1	V1 P80	V 1 C V 1 F	P80	BN80A4	190-191
50	9.5	86	228	2.3	0.9	20.0	3940	C212_20.0	— P80	— V 1 F	P80	BN80A4	186-187







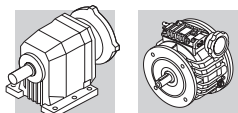

## 0.55 kW

$n_2$ min <sup>-1</sup>	$n_2'$ min <sup>-1</sup>	M <sub>2</sub> Nm	M <sub>2'</sub> Nm	S	S'	i	R <sub>n2</sub> N					IEC 	
53	10.0	81	217	4.7	1.8	19.0	6500	C352_19.0	V1 P80	V 1 C V 1 F	P80	BN80A4	190-191
54	10.3	70	175	2.6	1.1	36.8	3920	C212_36.8	V05 P71	V 0.5 C V 0.5 F	P71	BN71B2	186-187
56	10.6	77	137	2.6	1.5	18.0	3840	C212_18.0	V05 P71	V 0.5 C V 0.5 F	P80	BN80A4	186-187
63	12.0	68	180	3.0	1.1	15.8	3720	C212_15.8	— P80	— V 1 F	P80	BN80A4	186-187
63	12.0	68	120	3.0	1.7	15.8	3720	C212_15.8	V05 P71	V 0.5 C V 0.5 F	P80	BN80A4	186-187
68	12.8	56	141	3.1	1.4	29.6	3710	C212_29.6	V05 P71	V 0.5 C V 0.5 F	P71	BN71B2	186-187
75	14.2	57	102	1.4	0.9	13.4	2000	C112_13.4	V05 P71	V 0.5 C V 0.5 F	P80	BN80A4	184-185
81	15.3	53	141	3.5	1.4	12.4	3500	C212_12.4	— P80	— V 1 F	P80	BN80A4	186-187
82	15.6	46	115	3.5	1.7	24.3	3510	C212_24.3	V05 P71	V 0.5 C V 0.5 F	P71	BN71B2	186-187
83	15.7	52	92	1.5	1.0	12.1	2000	C112_12.1	V05 P71	V 0.5 C V 0.5 F	P80	BN80A4	184-185
93	17.6	40	108	3.7	1.7	7.1	3390	C212_7.1	— P80	— V 1 F	P80	BN80B6	186-187
96	18.1	39	52	1.6	1.4	6.9	2000	C112_6.9	V05 P71	V 0.5 C V 0.5 F	P80	BN80B6	184-185
100	19.0	38	95	3.9	2.1	20.0	3330	C212_20.0	V05 P71	V 0.5 C V 0.5 F	P71	BN71B2	186-187
103	19.6	41	111	4.1	1.8	9.7	3260	C212_9.7	— P80	— V 1 F	P80	BN80A4	186-187
103	19.6	41	74	4.1	2.7	9.7	3260	C212_9.7	V05 P71	V 0.5 C V 0.5 F	P80	BN80A4	186-187
110	20.9	39	69	1.8	1.2	9.1	1990	C112_9.1	V05 P71	V 0.5 C V 0.5 F	P80	BN80A4	184-185
116	22.1	33	82	1.8	1.1	17.2	1990	C112_17.2	V05 P71	V 0.5 C V 0.5 F	P71	BN71B2	184-185
129	24.5	29	74	2.0	1.3	15.5	1930	C112_15.5	V05 P71	V 0.5 C V 0.5 F	P71	BN71B2	184-185
139	26.4	31	82	7.6	3.5	7.2	4460	C312_7.2	V1 P80	V 1 C V 1 F	P80	BN80A4	188-189
141	26.8	30	81	4.9	2.2	7.1	2990	C212_7.1	— P80	— V 1 F	P80	BN80A4	186-187
149	28.4	25	64	2.2	1.4	13.4	1860	C112_13.4	V05 P71	V 0.5 C V 0.5 F	P71	BN71B2	184-185
159	30	27	72	6.6	2.8	6.3	4120	C312_6.3	V1 P80	V 1 C V 1 F	P80	BN80A4	188-189
161	31	24	59	5.3	3.4	12.4	2910	C212_12.4	V05 P71	V 0.5 C V 0.5 F	P71	BN71B2	186-187
164	31	26	70	4.2	1.7	6.1	2820	C212_6.1	— P80	— V 1 F	P80	BN80A4	186-187
198	38	19	48	2.6	1.8	10.1	1720	C112_10.1	V05 P71	V 0.5 C V 0.5 F	P71	BN71B2	184-185
204	39	21	37	2.6	1.8	4.9	1650	C112_4.9	V05 P71	V 0.5 C V 0.5 F	P80	BN80A4	184-185
206	39	18	46	6.2	4.3	9.7	2670	C212_9.7	V05 P71	V 0.5 C V 0.5 F	P71	BN71B2	186-187
208	40	21	55	5.1	1.9	4.8	2630	C212_4.8	— P80	— V 1 F	P80	BN80A4	186-187
263	50	14	36	3.1	2.2	7.6	1580	C112_7.6	V05 P71	V 0.5 C V 0.5 F	P71	BN71B2	184-185
323	61	12	29	3.6	2.4	6.2	1460	C112_6.2	V05 P71	V 0.5 C V 0.5 F	P71	BN71B2	184-185
357	68	12	21	3.6	2.5	2.8	1400	C112_2.8	V05 P71	V 0.5 C V 0.5 F	P80	BN80A4	184-185
408	78	9	23	4.1	2.9	4.9	1360	C112_4.9	V05 P71	V 0.5 C V 0.5 F	P71	BN71B2	184-185
541	103	7	18	4.8	3.4	3.7	1240	C112_3.7	V05 P71	V 0.5 C V 0.5 F	P71	BN71B2	184-185
714	136	5	13	5.6	4.0	2.8	1140	C112_2.8	V05 P71	V 0.5 C V 0.5 F	P71	BN71B2	184-185







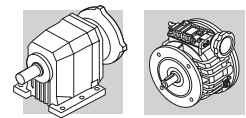

## 0.75 kW

$n_2$ min <sup>-1</sup>	$n_2'$ min <sup>-1</sup>	M <sub>2</sub> Nm	M <sub>2'</sub> Nm	S	S'	i	R <sub>n2</sub> N						
3.0	0.60	1643	3287	1.4	0.7	220.9	25000	C703_220.9	— P80	— V 1 F	P80	BN80C6	198-199
3.4	0.60	1444	2888	1.6	0.8	194.1	25000	C703_194.1	— P80	— V 1 F	P80	BN80C6	198-199
3.6	0.69	1503	2004	1.1	0.8	275.3	16000	C614_275.3	V05 P71	V 0.5 C V 0.5 F	P80	BN80B4	196-197
3.7	0.70	1333	2666	1.7	0.9	179.2	25000	C703_179.2	— P80	— V 1 F	P80	BN80C6	198-199
4.2	0.80	1335	3561	1.7	0.6	239.3	25000	C703_239.3	— P80	— V 1 F	P80	BN80B4	198-199
4.4	0.83	1116	2232	1.4	0.7	150.0	16000	C613_150.0	— P80	— V 1 F	P80	BN80C6	196-197
4.5	0.90	1233	3287	1.8	0.7	220.9	25000	C703_220.9	— P80	— V 1 F	P80	BN80B4	198-199
4.8	0.90	1022	2045	2.2	1.1	137.4	25000	C703_137.4	— P80	— V 1 F	P80	BN80C6	198-199
5.2	0.98	953	1906	1.7	0.8	128.1	16000	C613_128.1	— P80	— V 1 F	P80	BN80C6	196-197
5.2	1.0	1083	2888	2.1	0.8	194.1	25000	C703_194.1	— P80	— V 1 F	P80	BN80B4	198-199
5.6	1.1	1000	2666	2.3	0.9	179.2	25000	C703_179.2	— P80	— V 1 F	P80	BN80B4	198-199
5.8	1.1	845	1690	1.9	0.9	113.6	16000	C613_113.6	— P80	— V 1 F	P80	BN80C6	196-197
6.1	1.2	908	2422	2.5	0.9	162.8	25000	C703_162.8	— P80	— V 1 F	P80	BN80B4	198-199
6.4	1.2	771	1542	2.1	1.0	103.6	16000	C613_103.6	— P80	— V 1 F	P80	BN80C6	196-197
6.7	1.3	837	2232	1.9	0.7	150.0	16000	C613_150.0	— P80	— V 1 F	P80	BN80B4	196-197
6.7	1.3	839	2236	2.7	1.0	150.3	25000	C703_150.3	— P80	— V 1 F	P80	BN80B4	198-199
7.3	1.4	677	1354	2.4	1.2	91.0	16000	C613_91.0	— P80	— V 1 F	P80	BN80C6	196-197
7.3	1.4	767	2045	3.0	1.1	137.4	25000	C703_137.4	— P80	— V 1 F	P80	BN80B4	198-199
7.9	1.5	708	1887	3.3	1.2	126.8	25000	C703_126.8	— P80	— V 1 F	P80	BN80B4	198-199
8.0	1.5	618	1235	2.6	1.3	83.0	16000	C613_83.0	— P80	— V 1 F	P80	BN80C6	196-197
8.3	1.6	594	1189	1.7	0.8	79.9	10000	C513_79.9	— P80	— V 1 F	P80	BN80C6	194-195
8.8	1.7	634	1690	2.5	0.9	113.6	16000	C613_113.6	— P80	— V 1 F	P80	BN80B4	196-197
8.9	1.7	627	1673	3.7	1.4	112.4	25000	C703_112.4	— P80	— V 1 F	P80	BN80B4	198-199
9.7	1.8	578	1542	2.8	1.0	103.6	16000	C613_103.6	— P80	— V 1 F	P80	BN80B4	196-197
9.8	1.9	571	761	1.1	0.8	102.3	7000	C413_102.3	V05 P71	V 0.5 C V 0.5 F	P80	BN80B4	192-193
9.8	1.9	568	1515	1.8	0.7	101.8	10000	C513_101.8	— P80	— V 1 F	P80	BN80B4	194-195
11.0	2.1	508	1354	3.2	1.2	91.0	16000	C613_91.0	— P80	— V 1 F	P80	BN80B4	196-197
11.9	2.3	468	623	1.0	0.7	83.8	6500	C353_83.8	V05 P71	V 0.5 C V 0.5 F	P80	BN80B4	190-191
12.3	2.3	455	606	1.3	1.0	81.5	7000	C413_81.5	V05 P71	V 0.5 C V 0.5 F	P80	BN80B4	192-193
13.7	2.6	407	1085	2.5	0.9	72.9	10000	C513_72.9	— P80	— V 1 F	P80	BN80B4	194-195
14.1	2.7	350	699	1.7	0.9	47.0	7000	C413_47.0	V1 P80	V 1 C V 1 F	P80	BN80C6	192-193
14.1	2.7	395	526	1.1	0.9	70.7	6500	C353_70.7	V05 P71	V 0.5 C V 0.5 F	P80	BN80B4	190-191
16.9	3.2	329	878	3.0	1.1	59.0	10000	C513_59.0	— P80	— V 1 F	P80	BN80B4	194-195
17.0	3.2	328	437	1.8	1.4	58.7	7000	C413_58.7	V05 P71	V 0.5 C V 0.5 F	P80	BN80B4	192-193
17.0	3.2	328	873	1.8	0.7	58.7	7000	C413_58.7	V1 P80	V 1 C V 1 F	P80	BN80B4	192-193
19.4	3.7	287	383	2.1	1.6	51.5	7000	C413_51.5	V05 P71	V 0.5 C V 0.5 F	P80	BN80B4	192-193



## 0.75 kW

$n_2$ min <sup>-1</sup>	$n_2'$ min <sup>-1</sup>	$M_2$ Nm	$M_2'$ Nm	S	S'	i	R <sub>n2</sub> N					IEC 	
19.4	3.7	287	766	2.1	0.8	51.5	7000	C413_51.5	V1 P80	V 1 C V 1 F	P80	BN80B4	192-193
21.3	4.0	262	350	2.3	1.7	47.0	7000	C413_47.0	V05 P71	V 0.5 C V 0.5 F	P80	BN80B4	192-193
21.3	4.0	262	699	2.3	0.9	47.0	7000	C413_47.0	V1 P80	V 1 C V 1 F	P80	BN80B4	192-193
24.8	4.7	225	600	2.7	1.0	40.3	7000	C413_40.3	V1 P80	V 1 C V 1 F	P80	BN80B4	192-193
26.2	5.0	213	283	2.1	1.6	38.1	6500	C353_38.1	V05 P71	V 0.5 C V 0.5 F	P80	BN80B4	190-191
28.8	5.5	194	258	2.3	1.7	34.7	6500	C353_34.7	V05 P71	V 0.5 C V 0.5 F	P80	BN80B4	190-191
28.8	5.5	194	516	2.3	0.9	34.7	6500	C353_34.7	V1 P80	V 1 C V 1 F	P80	BN80B4	190-191
35	6.6	160	214	2.8	2.1	28.7	6500	C353_28.7	V05 P71	V 0.5 C V 0.5 F	P80	BN80B4	190-191
35	6.6	160	427	2.8	1.1	28.7	6500	C353_28.7	V1 P80	V 1 C V 1 F	P80	BN80B4	190-191
37	7.1	153	407	2.0	0.7	26.8	5500	C312_26.8	V1 P80	V 1 C V 1 F	P80	BN80B4	188-189
38	7.3	146	195	3.1	2.3	26.2	6500	C353_26.2	V05 P71	V 0.5 C V 0.5 F	P80	BN80B4	190-191
38	7.3	146	390	3.1	1.2	26.2	6500	C353_26.2	V1 P80	V 1 C V 1 F	P80	BN80B4	190-191
43	8.0	119	237	2.5	1.3	15.6	5500	C312_15.6	V1 P80	V 1 C V 1 F	P80	BN80C6	188-189
45	8.6	123	329	3.6	1.4	22.1	6500	C353_22.1	V1 P80	V 1 C V 1 F	P80	BN80B4	190-191
50	9.5	114	304	1.8	0.7	20.0	3760	C212_20.0	— P80	— V 1 F	P80	BN80B4	186-187
54	10.3	105	280	1.8	0.7	36.8	3690	C212_36.8	V05 P71	V 0.5 C V 0.5 F	P71	BN71C2	186-187
55	10.5	103	274	2.7	1.1	36.1	5500	C312_36.1	V05 P71	V 0.5 C V 0.5 F	P71	BN71C2	188-189
64	12.2	89	237	3.4	1.3	15.6	5350	C312_15.6	V1 P80	V 1 C V 1 F	P80	BN80B4	188-189
68	12.8	84	225	2.1	0.9	29.6	3520	C212_29.6	V05 P71	V 0.5 C V 0.5 F	P71	BN71C2	186-187
71	13.6	80	213	3.8	1.4	14.0	5190	C312_14.0	V1 P80	V 1 C V 1 F	P80	BN80B4	188-189
80	15.1	72	191	3.5	1.6	25.1	5030	C312_25.1	V05 P71	V 0.5 C V 0.5 F	P71	BN71C2	188-189
81	15.3	71	94	2.6	2.1	12.4	3380	C212_12.4	V05 P71	V 0.5 C V 0.5 F	P80	BN80B4	186-187
81	15.4	70	187	4.1	1.6	12.3	5010	C312_12.3	V1 P80	V 1 C V 1 F	P80	BN80B4	188-189
92	17.4	55	109	4.3	2.6	7.2	4860	C312_7.2	V1 P80	V 1 C V 1 F	P80	BN80C6	188-189
97	18.4	59	157	1.1	0.6	20.6	1960	C112_20.6	V05 P71	V 0.5 C V 0.5 F	P71	BN71C2	184-185
100	19.0	57	152	2.6	1.3	20.0	3200	C212_20.0	V05 P71	V 0.5 C V 0.5 F	P71	BN71C2	186-187
103	19.6	55	147	3.1	1.4	9.7	3170	C212_9.7	— P80	— V 1 F	P80	BN80B4	186-187
108	20.4	53	141	4.9	2.1	9.3	4620	C312_9.3	V1 P80	V 1 C V 1 F	P80	BN80B4	188-189
115	21.8	50	132	3.3	1.5	8.7	3080	C212_8.7	— P80	— V 1 F	P80	BN80B4	186-187
127	24.1	45	120	3.1	1.7	15.8	3010	C212_15.8	V05 P71	V 0.5 C V 0.5 F	P71	BN71C2	186-187
140	26.6	41	109	3.3	1.8	14.3	2920	C212_14.3	V05 P71	V 0.5 C V 0.5 F	P715	BN71C2	186-187
141	26.8	40	108	3.7	1.7	7.1	2920	C212_7.1	— P80	— V 1 F	P80	BN80B4	186-187
149	28.4	38	102	1.4	0.9	13.4	1780	C112_13.4	V05 P71	V 0.5 C V 0.5 F	P71	BN71C2	184-185
161	31	35	94	3.5	2.1	12.4	2820	C212_12.4	V05 P71	V 0.5 C V 0.5 F	P71	BN71C2	186-187
164	31	35	93	3.2	1.3	6.1	2840	C212_6.1	— P80	— V 1 F	P80	BN80B4	186-187
165	31	34	92	1.5	1.0	12.1	1730	C112_12.1	V05 P71	V 0.5 C V 0.5 F	P71	BN71C2	184-185

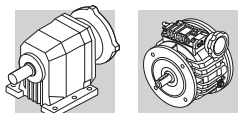

## 0.75 kW





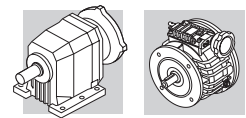

$n_2$ min <sup>-1</sup>	$n_2'$ min <sup>-1</sup>	$M_2$ Nm	$M_2'$ Nm	S	S'	i	R <sub>n2</sub> N						
200	38	29	76	5.7	2.6	5.0	3820	C312_5.0	V1 P80	V 1 C V 1 F	P80	BN80B4	188-189
206	39	28	74	4.2	2.7	9.7	2620	C212_9.7	V05 P71	V 0.5 C V 0.5 F	P71	BN71C2	186-187
208	40	27	36	3.8	2.9	4.8	2590	C212_4.8	V05 P71	V 0.5 C V 0.5 F	P80	BN80B4	186-187
263	50	22	58	2.1	1.4	7.6	1550	C112_7.6	V05 P71	V 0.5 C V 0.5 F	P71	BN71C2	184-185
323	61	18	47	2.4	1.5	6.2	1430	C112_6.2	V05 P71	V 0.5 C V 0.5 F	P71	BN71C2	184-185
357	68	16	21	2.7	2.5	2.8	1380	C112_2.8	V05 P71	V 0.5 C V 0.5 F	P80	BN80B4	184-185
408	78	14	37	2.7	1.8	4.9	1330	C112_4.9	V05 P71	V 0.5 C V 0.5 F	P71	BN71C2	184-185
541	103	11	28	3.2	2.1	3.7	1220	C112_3.7	V05 P71	V 0.5 C V 0.5 F	P71	BN71C2	184-185
714	136	8	21	3.8	2.5	2.8	1130	C112_2.8	V05 P71	V 0.5 C V 0.5 F	P71	BN71C2	184-185

## 1.1 kW

3.6	0.70	2058	5488	1.9	0.7	184.4	35000	C803_184.4	— P90	— V 2 F	P90	BN90L6	200
3.9	0.70	1886	5029	2.1	0.8	169.0	35000	C803_169.0	— P90	— V 2 F	P90	BN90L6	200
4.4	0.80	1664	4437	2.4	0.9	149.1	35000	C803_149.1	— P90	— V 2 F	P90	BN90L6	200
4.6	0.90	1807	4819	2.2	0.8	215.9	35000	C803_215.9	— P90	— V 2 F	P90	BN90S4	200
4.7	0.98	1430	1906	1.1	0.8	128.1	16000	C613_128.1	— P80	— V 1 F	P90	BN90L6	196-197
4.9	0.90	1526	4068	2.6	1.0	136.7	35000	C803_136.7	— P90	— V 2 F	P90	BN90L6	200
5.1	1.0	1656	4417	2.3	0.9	197.9	35000	C803_197.9	— P90	— V 2 F	P90	BN90S4	200
5.2	1.1	1268	1690	1.3	0.9	113.6	16000	C613_113.6	— P80	— V 1 F	P90	BN90L6	196-197
5.4	1.0	1543	4116	2.6	1.0	184.4	35000	C803_184.4	— P90	— V 2 F	P90	BN90S4	200
5.8	1.2	1156	1542	1.4	1.0	103.6	16000	C613_103.6	— P80	— V 1 F	P90	BN90L6	196-197
5.9	1.1	1415	3772	2.8	1.1	169.0	35000	C803_169.0	— P90	— V 2 F	P90	BN90S4	200
6.7	1.3	1248	3328	3.2	1.2	149.1	35000	C803_149.1	— P90	— V 2 F	P90	BN90S4	200
7.0	1.5	1084	1906	1.5	0.8	128.1	16000	C613_128.1	— P80	— V 1 F	P90	BN90S4	196-197
7.3	1.4	1144	3051	3.5	1.3	136.7	35000	C803_136.7	— P90	— V 2 F	P90	BN90S4	200
7.5	1.6	892	1189	1.1	0.8	79.9	10000	C513_79.9	— P80	— V 1 F	P90	BN90L6	194-195
7.5	1.4	984	2625	2.3	0.9	88.2	25000	C703_88.2	— P90	— V 2 F	P90	BN90L6	198-199
7.9	1.5	1061	2830	2.2	0.8	126.8	25000	C703_126.8	— P90	— V 2 F	P90	BN90S4	198-199
7.9	1.7	961	1690	1.7	0.9	113.6	16000	C613_113.6	— P80	— V 1 F	P90	BN90S4	196-197
8.4	1.6	1000	2667	4.0	1.5	119.5	25000	C803_119.5	— P90	— V 2 F	P90	BN90S4	200
8.7	1.8	877	1542	1.8	1.0	103.6	16000	C613_103.6	— P80	— V 1 F	P90	BN90S4	196-197
8.9	1.7	941	2509	2.4	0.9	112.4	25000	C703_112.4	— P90	— V 2 F	P90	BN90S4	198-199
9.1	1.7	917	2444	4.4	1.6	109.5	35000	C803_109.5	— P90	— V 2 F	P90	BN90S4	200
9.6	1.8	869	2317	2.6	1.0	103.8	25000	C703_103.8	— P90	— V 2 F	P90	BN90S4	198-199







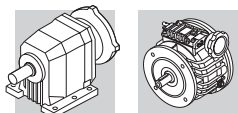

# 1.1 kW

$n_2$ min <sup>-1</sup>	$n_2'$ min <sup>-1</sup>	M <sub>2</sub> Nm	M <sub>2'</sub> Nm	S	S'	i	R <sub>n2</sub> N					IEC 	
9.7	1.8	867	2312	1.8	0.7	103.6	16000	C613_103.6	V2 P90	V 2 C V 2 F	P90	BN90S4	196-197
9.9	2.1	770	1354	2.1	1.2	91.0	16000	C613_91.0	— P80	— V 1 F	P90	BN90S4	196-197
10.1	1.9	735	1961	3.1	1.2	65.9	25000	C703_65.9	— P90	— V 2 F	P90	BN90L6	198-199
11.0	2.1	762	2031	2.1	0.8	91.0	16000	C613_91.0	V2 P90	V 2 C V 2 F	P90	BN90S4	196-197
11.2	2.1	750	2000	3.1	1.2	179.2	25000	C703_179.2	— P80	— V 1 F	P80	BN80B2	198-199
11.3	2.4	676	1189	1.5	0.8	79.9	10000	C513_79.9	— P80	— V 1 F	P90	BN90S4	194-195
11.3	2.2	738	1969	3.1	1.2	88.2	25000	C703_88.2	— P90	— V 2 F	P90	BN90S4	198-199
12.3	2.3	681	1817	3.4	1.3	81.4	25000	C703_81.4	— P90	— V 2 F	P90	BN90S4	198-199
12.3	2.6	617	1085	1.6	0.9	72.9	10000	C513_72.9	— P80	— V 1 F	P90	BN90S4	194-195
12.4	2.3	597	1592	2.7	1.0	53.5	16000	C613_53.5	V2 P90	V 2 C V 2 F	P90	BN90L6	196-197
12.9	2.4	571	1524	1.8	0.7	51.2	10000	C513_51.2	V2 P90	V 2 C V 2 F	P90	BN90L6	194-195
13.3	2.8	511	681	1.0	0.7	44.8	7000	C412_44.8	V1 P80	V 1 C V 1 F	P90	BN90L6	192-193
13.5	2.6	621	1656	2.6	1.0	74.2	16000	C613_74.2	V2 P90	V 2 C V 2 F	P90	BN90S4	196-197
15.3	3.2	499	878	2.0	1.1	59.0	10000	C513_59.0	— P80	— V 1 F	P90	BN90S4	194-195
15.3	3.2	497	873	1.2	0.7	58.7	7000	C413_58.7	V1 P80	V 1 C V 1 F	P90	BN90S4	192-193
15.5	2.9	541	1442	1.8	0.7	64.6	10000	C513_64.6	V2 P90	V 2 C V 2 F	P90	BN90S4	194-195
16.9	3.2	494	1317	2.0	0.8	59.0	10000	C513_59.0	V2 P90	V 2 C V 2 F	P90	BN90S4	194-195
17.1	3.2	490	1308	3.3	1.2	58.6	16000	C613_58.6	V2 P90	V 2 C V 2 F	P90	BN90S4	196-197
17.5	3.7	436	766	1.4	0.8	51.5	7000	C413_51.5	V1 P80	V 1 C V 1 F	P90	BN90S4	192-193
18.7	3.6	448	1194	3.6	1.3	53.5	16000	C613_53.5	V2 P90	V 2 C V 2 F	P90	BN90S4	196-197
19.0	4.0	358	477	1.4	1.0	31.4	7000	C412_31.4	V1 P80	V 1 C V 1 F	P90	BN90L6	192-193
19.3	4.1	395	695	2.5	1.4	46.7	10000	C513_46.7	— P80	— V 1 F	P90	BN90S4	194-195
21.4	4.1	391	1042	2.6	1.0	46.7	10000	C513_46.7	V2 P90	V 2 C V 2 F	P90	BN90S4	194-195
21.8	4.6	306	408	3.3	2.5	27.4	10000	C513_27.4	— P80	— V 1 F	P90	BN90L6	194-195
23.2	4.4	369	983	2.2	0.8	43.1	10000	C512_43.1	V2 P90	V 2 C V 2 F	P90	BN90S4	194-195
23.3	4.4	318	848	1.9	0.7	28.5	7000	C413_28.5	V2 P90	V 2 C V 2 F	P90	BN90L6	192-193
24.8	4.7	345	921	2.3	0.9	40.4	10000	C512_40.4	V2 P90	V 2 C V 2 F	P90	BN90S4	194-195
25.9	5.5	294	516	1.5	0.9	34.7	6500	C353_34.7	V1 P80	V 1 C V 1 F	P90	BN90S4	190-191
26.3	5.0	325	866	4.2	1.6	38.0	16000	C612_38.0	V2 P90	V 2 C V 2 F	P90	BN90S4	196-197
26.5	5.0	285	760	1.8	0.7	25.0	7000	C412_25.0	V2 P90	V 2 C V 2 F	P90	BN90L6	192-193
30	5.8	282	752	2.8	1.1	33.0	10000	C512_33.0	V2 P90	V 2 C V 2 F	P90	BN90S4	194-195
31	5.9	269	718	2.1	0.8	64.3	7000	C413_64.3	V1 P80	V 1 C V 1 F	P80	BN80B2	192-193
32	6.1	268	716	1.9	0.7	31.4	7000	C412_31.4	V2 P90	V 2 C V 2 F	P90	BN90S4	192-193
35	6.7	242	645	2.1	0.8	28.3	7000	C412_28.3	V2 P90	V 2 C V 2 F	P90	BN90S4	192-193
39	7.3	221	591	3.6	1.4	25.9	10000	C512_25.9	V2 P90	V 2 C V 2 F	P90	BN90S4	194-195



# 1.1 kW

$n_2$ min <sup>-1</sup>	$n_2'$ min <sup>-1</sup>	M <sub>2</sub> Nm	M <sub>2'</sub> Nm	S	S'	i	R <sub>n2</sub> N					IEC 	
40	7.6	214	570	2.3	0.9	25.0	7000	C412_25.0	V2 P90	V 2 C V 2 F	P90	BN90S4	192-193
41	8.6	187	329	2.4	1.4	22.1	6430	C353_22.1	V1 P80	V 1 C V 1 F	P90	BN90S4	190-191
42	7.9	180	480	2.8	1.0	15.8	7000	C412_15.8	V2 P90	V 2 C V 2 F	P90	BN90L6	192-193
43	8.1	200	534	4.0	1.5	23.4	10000	C512_23.4	V2 P90	V 2 C V 2 F	P90	BN90S4	194-195
45	8.4	169	450	2.3	0.8	14.8	6500	C352_14.8	— P90	— V 2 F	P90	BN90L6	190-191
48	9.0	180	479	4.5	1.7	21.0	10000	C512_21.0	V2 P90	V 2 C V 2 F	P90	BN90S4	194-195
50	9.4	169	451	2.7	1.0	20.2	6270	C353_20.2	— P90	— V 2 F	P90	BN90S4	190-191
51	9.6	169	451	3.0	1.1	19.8	7000	C412_19.8	V2 P90	V 2 C V 2 F	P90	BN90S4	192-193
53	10.1	141	377	3.5	1.3	12.4	7000	C412_12.4	V2 P90	V 2 C V 2 F	P90	BN90L6	192-193
54	10.2	159	423	3.0	1.2	37.1	7000	C412_37.1	V1 P80	V 1 C V 1 F	P80	BN80B2	192-193
60	11.4	142	378	5.6	2.1	16.6	10000	C512_16.6	V2 P90	V 2 C V 2 F	P90	BN90S4	194-195
63	11.9	120	319	3.2	1.2	10.5	5970	C352_10.5	— P90	— V 2 F	P90	BN90L6	190-191
63	12.0	135	360	3.7	1.4	15.8	6900	C412_15.8	V2 P90	V 2 C V 2 F	P90	BN90S4	192-193
67	12.8	127	340	2.1	0.9	29.8	5060	C312_29.8	V1 P80	V 1 C V 1 F	P80	BN80B2	188-189
70	13.4	121	324	4.1	1.5	14.2	6700	C412_14.2	V2 P90	V 2 C V 2 F	P90	BN90S4	192-193
71	13.4	106	283	2.5	1.1	9.3	5060	C312_9.3	— P90	— V 2 F	P90	BN90L6	188-189
80	15.1	107	286	2.3	1.0	25.1	4850	C312_25.1	V1 P80	V 1 C V 1 F	P80	BN80B2	188-189
81	15.3	106	283	4.7	1.8	12.4	6700	C412_12.4	V2 P90	V 2 C V 2 F	P90	BN90S4	192-193
93	17.6	81	216	5.1	2.3	7.1	6240	C412_7.1	V2 P90	V 2 C V 2 F	P90	BN90L6	192-193
100	18.9	86	229	2.7	1.3	20.1	4570	C312_20.1	V1 P80	V 1 C V 1 F	P80	BN80B2	188-189
101	19.2	85	226	4.5	2.2	19.8	6050	C412_19.8	V1 P80	V 1 C V 1 F	P80	BN80B2	192-193
104	19.8	82	219	5.5	2.3	9.6	6000	C412_9.6	V2 P90	V 2 C V 2 F	P90	BN90S4	192-193
108	20.4	80	212	3.3	1.4	9.3	4480	C312_9.3	— P90	— V 2 F	P90	BN90S4	188-189
111	20.8	68	182	3.8	1.4	6.0	5800	C412_6.0	V2 P90	V 2 C V 2 F	P90	BN90L6	192-193
127	24.1	68	180	2.1	1.1	15.8	2860	C212_15.8	— P80	— V 1 F	P80	BN80B2	186-187
128	24.4	67	178	3.2	1.7	15.6	4270	C312_15.6	V1 P80	V 1 C V 1 F	P80	BN80B2	188-189
139	26.4	62	164	3.8	1.7	7.2	4170	C312_7.2	— P90	— V 2 F	P90	BN90S4	188-189
140	26.6	61	163	2.2	1.2	14.3	2790	C212_14.3	— P80	— V 1 F	P80	BN80B2	186-187
141	26.8	61	162	6.8	3.1	7.1	5500	C412_7.1	V2 P90	V 2 C V 2 F	P90	BN90S4	192-193
159	30	54	144	3.3	1.4	6.3	3950	C312_6.3	— P90	— V 2 F	P90	BN90S4	188-189
161	31	53	141	2.4	1.4	12.4	2700	C212_12.4	— P80	— V 1 F	P80	BN80B2	186-187
163	31	53	140	3.7	2.1	12.3	3990	C312_12.3	V1 P80	V 1 C V 1 F	P80	BN80B2	188-189
167	32	51	137	5.1	1.9	6.0	5200	C412_6.0	V2 P90	V 2 C V 2 F	P90	BN90S4	192-193
200	38	43	114	3.8	1.7	5.0	3700	C312_5	— P90	— V 2 F	P90	BN90S4	188-189
206	39	41	111	2.8	1.8	9.7	2530	C212_9.7	— P80	— V 1 F	P80	BN80B2	186-187



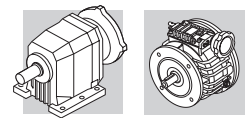

## 1.1 kW





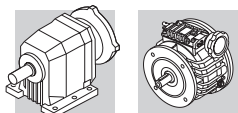

$n_2$ min <sup>-1</sup>	$n_2'$ min <sup>-1</sup>	$M_2$ Nm	$M_2'$ Nm	$S$	$S'$	$i$	$R_{n2}$ N						
213	40	40	107	6.5	2.4	4.7	5000	<b>C412_4.7</b>	V2 P90	V 2 C V 2 F	P90	BN90S4	192-193
215	41	40	106	4.4	2.8	9.3	3670	<b>C312_9.3</b>	V1 P80	V 1 C V 1 F	P80	BN80B2	188-189
278	53	31	82	5.2	3.5	7.2	3400	<b>C312_7.2</b>	V1 P80	V 1 C V 1 F	P80	BN80B2	188-189
282	54	30	81	3.5	2.2	7.1	2330	<b>C212_7.1</b>	— P80	— V 1 F	P80	BN80B2	186-187
317	60	27	72	5.6	2.8	6.3	3230	<b>C312_6.3</b>	V1 P80	V 1 C V 1 F	P80	BN80B2	188-189
328	62	26	70	3.3	1.7	6.1	2210	<b>C212_6.1</b>	— P80	— V 1 F	P80	BN80B2	186-187
400	76	21	57	6.3	3.5	5.0	3020	<b>C312_5.0</b>	V1 P80	V 1 C V 1 F	P80	BN80B2	188-189
417	79	21	55	3.9	1.9	4.8	2060	<b>C212_4.8</b>	— P80	— V 1 F	P80	BN80B2	186-187
541	103	16	28	2.1	2.1	3.7	1190	<b>C112_3.7</b>	V05 P71	V 0.5 C V 0.5 F	P80	BN80B2	184-185
541	103	16	42	7.6	4.1	3.7	2760	<b>C312_3.7</b>	V1 P80	V 1 C V 1 F	P80	BN80B2	188-189
714	136	12	21	2.5	2.5	2.8	1100	<b>C112_2.8</b>	V05 P71	V 0.5 C V 0.5 F	P80	BN80B2	184-185
741	141	12	31	5.6	3.2	2.7	1750	<b>C212_2.7</b>	— P80	— V 1 F	P80	BN80B2	186-187

## 1.5 kW

3.1	0.60	3213	7028	1.2	0.6	215.9	35000	<b>C803_215.9</b>	— P90	— V 2 F	P90	BN100LA6R	200
3.4	0.60	2945	6442	1.3	0.6	197.9	35000	<b>C803_197.9</b>	— P90	— V 2 F	P90	BN100LA6R	200
3.6	0.70	2744	6002	1.5	0.7	184.4	35000	<b>C803_184.4</b>	— P90	— V 2 F	P90	BN100LA6R	200
3.9	0.70	2515	5501	1.6	0.7	169.0	35000	<b>C803_169.0</b>	— P90	— V 2 F	P90	BN100LA6R	200
4.4	0.80	2219	4853	1.8	0.8	149.1	35000	<b>C803_149.1</b>	— P90	— V 2 F	P90	BN100LA6R	200
4.9	0.90	2034	4450	2.0	0.9	136.7	35000	<b>C803_136.7</b>	— P90	— V 2 F	P90	BN100LA6R	200
5.4	1.0	2058	5488	1.9	0.7	184.4	35000	<b>C803_184.4</b>	— P90	— V 2 F	P90	BN90LA4	200
5.9	1.1	1886	5029	2.1	0.8	169.0	35000	<b>C803_169.0</b>	— P90	— V 2 F	P90	BN90LA4	200
6.0	1.3	1674	2232	1.0	0.7	150.0	16000	<b>C613_150.0</b>	— P80	— V 1 F	P90	BN90LA4	196-197
6.1	1.1	1629	3564	2.5	1.1	109.5	35000	<b>C803_109.5</b>	— P90	— V 2 F	P90	BN100LA6R	200
6.7	1.3	1664	4437	2.4	0.9	149.1	35000	<b>C803_149.1</b>	— P90	— V 2 F	P90	BN90LA4	200
6.8	1.3	1449	3170	2.8	1.3	97.4	35000	<b>C803_97.4</b>	— P90	— V 2 F	P90	BN100LA6R	200
7.3	1.4	1526	4068	2.6	1.0	136.7	35000	<b>C803_136.7</b>	— P90	— V 2 F	P90	BN90LA4	200
8.0	1.5	1235	2702	1.3	0.6	83.0	16000	<b>C613_83.0</b>	V2 P90	V 2 C V 2 F	P90	BN100LA6R	196-197
8.4	1.6	1335	3561	1.7	0.6	239.3	25000	<b>C703_239.3</b>	— P80	— V 1 F	P80	BN80C2	198-199
8.4	1.6	1334	3556	3.0	1.1	119.5	35000	<b>C803_119.5</b>	— P90	— V 2 F	P90	BN90LA4	200
9.1	1.7	1233	3287	1.8	0.7	220.9	25000	<b>C703_220.9</b>	— P80	— V 1 F	P80	BN80C2	198-199
9.1	1.7	1222	3259	3.3	1.2	109.5	35000	<b>C803_109.5</b>	— P90	— V 2 F	P90	BN90LA4	200
9.3	1.8	1061	2321	2.2	1.0	71.3	25000	<b>C703_71.3</b>	— P90	— V 2 F	P90	BN100LA6R	198-199







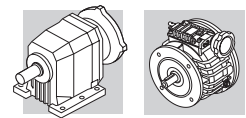

# 1.5 kW

$n_2$ min <sup>-1</sup>	$n_2'$ min <sup>-1</sup>	M <sub>2</sub> Nm	M <sub>2'</sub> Nm	S	S'	i	R <sub>n2</sub> N						
9.8	1.8	1007	2204	1.6	0.7	67.7	16000	C613_67.7	V2 P90	V 2 C V 2 F	P90	BN100LA6R	196-197
10.3	2.0	1083	2888	2.1	0.8	194.1	25000	C703_194.1	— P80	— V 1 F	P80	BN80C2	198-199
10.3	2.0	1087	2899	3.7	1.4	97.4	35000	C803_97.4	— P90	— V 2 F	P90	BN90LA4	200
11.2	2.1	997	2658	4.0	1.5	89.3	35000	C803_89.3	— P90	— V 2 F	P90	BN90LA4	200
11.3	2.2	984	2625	2.3	0.9	88.2	25000	C703_88.2	— P90	— V 2 F	P90	BN90LA4	198-199
11.7	2.2	841	1839	2.7	1.3	56.5	25000	C703_56.5	— P90	— V 2 F	P90	BN100LA6R	198-199
12.1	2.6	828	1104	1.9	1.4	74.2	16000	C613_74.2	— P80	— V 1 F	P90	BN90LA4	196-197
12.3	2.3	908	2422	2.5	0.9	81.4	25000	C703_81.4	— P90	— V 2 F	P90	BN90LA4	198-199
12.4	2.3	796	1741	2.0	0.9	53.5	16000	C613_53.5	V2 P90	V 2 C V 2 F	P90	BN100LA6R	196-197
13.0	2.5	858	2289	4.7	1.7	76.9	35000	C803_76.9	— P90	— V 2 F	P90	BN90LA4	200
13.3	2.5	839	2236	2.7	1.0	150.3	25000	C703_150.3	— P80	— V 1 F	P80	BN80C2	198-199
13.9	2.6	708	1549	2.3	1.0	47.6	16000	C613_47.6	V2 P90	V 2 C V 2 F	P90	BN100LA6R	196-197
14.0	2.7	796	2122	2.9	1.1	71.3	25000	C703_71.3	— P90	— V 2 F	P90	BN90LA4	198-199
14.2	2.7	787	2098	5.1	1.9	70.5	35000	C803_70.5	— P90	— V 2 F	P90	BN90LA4	200
15.2	2.9	735	1961	3.1	1.2	65.9	25000	C703_65.9	— P90	— V 2 F	P90	BN90LA4	198-199
16.0	3.0	698	1860	5.7	2.2	62.5	35000	C803_62.5	— P90	— V 2 F	P90	BN90LA4	200
17.1	3.2	654	1744	2.4	0.9	58.6	16000	C613_58.6	V2 P90	V 2 C V 2 F	P90	BN90LA4	196-197
17.7	3.4	631	1681	3.6	1.4	56.5	25000	C703_56.5	— P90	— V 2 F	P90	BN90LA4	198-199
18.7	3.6	597	1592	2.7	1.0	53.5	16000	C613_53.5	V2 P90	V 2 C V 2 F	P90	BN90LA4	196-197
19.1	4.0	525	699	1.1	0.9	47.0	7000	C413_47.0	V1 P80	V 1 C V 1 F	P90	BN90LA4	192-193
19.2	3.6	583	1553	3.9	1.5	52.2	25000	C703_52.2	— P90	— V 2 F	P90	BN90LA4	198-199
20.1	4.2	511	681	1.0	0.7	44.8	7000	C412_44.8	V1 P80	V 1 C V 1 F	P90	BN90LA4	192-193
21.0	4.0	531	1417	3.0	1.1	47.6	16000	C613_47.6	V2 P90	V 2 C V 2 F	P90	BN90LA4	196-197
22.4	4.3	499	1330	4.6	1.7	44.7	25000	C703_44.7	— P90	— V 2 F	P90	BN90LA4	198-199
23.0	4.4	484	1292	3.3	1.2	43.4	16000	C613_43.4	V2 P90	V 2 C V 2 F	P90	BN90LA4	196-197
23.2	4.4	491	1310	1.6	0.6	43.1	10000	C512_43.1	V2 P90	V 2 C V 2 F	P90	BN90LA4	194-195
24.2	4.6	461	1229	5.0	1.9	41.3	25000	C703_41.3	— P90	— V 2 F	P90	BN90LA4	198-199
24.5	4.7	455	1213	1.3	0.5	81.5	10000	C413_81.5	V1 P80	V 1 C V 1 F	P80	BN80C2	192-193
25.6	4.8	394	861	2.0	0.9	25.9	10000	C512_25.9	V2 P90	V 2 C V 2 F	P90	BN100LA6R	194-195
26.3	5.0	433	1155	3.1	1.2	38.0	16000	C612_38.0	V2 P90	V 2 C V 2 F	P90	BN90LA4	196-197
26.7	5.0	377	825	3.6	1.6	24.8	16000	C612_24.8	V2 P90	V 2 C V 2 F	P90	BN100LA6R	196-197
27.4	5.2	407	1085	2.5	0.9	72.9	10000	C513_72.9	— P80	— V 1 F	P80	BN80C2	194-195
30	5.8	376	1003	2.1	0.8	33.0	10000	C512_33.0	V2 P90	V 2 C V 2 F	P90	BN90LA4	194-195
32	6.0	319	698	2.5	1.1	21.0	10000	C512_21.0	V2 P90	V 2 C V 2 F	P90	BN100LA6R	194-195
33	6.3	347	924	3.9	1.5	30.4	16000	C612_30.4	V2 P90	V 2 C V 2 F	P90	BN90LA4	196-197



# 1.5 kW

$n_2$ min <sup>-1</sup>	$n_2'$ min <sup>-1</sup>	M <sub>2</sub> Nm	M <sub>2'</sub> Nm	S	S'	i	R <sub>n2</sub> N					IEC 	
35	6.7	318	848	1.9	0.7	28.5	7000	C413_28.5	V2 P90	V 2 C V 2 F	P90	BN90LA4	192-193
35	6.7	325	866	2.3	0.9	57.0	10000	C512_57.0	— P80	— V 1 F	P80	BN80C2	194-195
39	7.3	295	787	2.7	1.0	25.9	10000	C512_25.9	V2 P90	V 2 C V 2 F	P90	BN90LA4	194-195
40	7.7	283	754	4.8	1.8	24.8	16000	C612_24.8	V2 P90	V 2 C V 2 F	P90	BN90LA4	196-197
42	7.9	240	525	2.1	1.0	15.8	7000	C412_15.8	V2 P90	V 2 C V 2 F	P90	BN100LA6R	192-193
48	9.0	239	638	3.3	1.3	21.0	10000	C512_21.0	V2 P90	V 2 C V 2 F	P90	BN90LA4	194-195
51	9.6	226	602	2.2	0.8	19.8	7000	C412_19.8	V2 P90	V 2 C V 2 F	P90	BN90LA4	192-193
51	9.5	199	436	4.0	1.8	13.1	10000	C512_13.1	V2 P90	V 2 C V 2 F	P90	BN100LA6R	194-195
51	9.7	223	596	6.0	2.3	19.6	16000	C612_19.6	V2 P90	V 2 C V 2 F	P90	BN90LA4	196-197
54	10.2	211	564	2.2	0.9	37.1	6930	C412_37.1	V1 P80	V 1 C V 1 F	P80	BN80C2	192-193
60	11.4	189	505	4.2	1.6	16.6	10000	C512_16.6	V2 P90	V 2 C V 2 F	P90	BN90LA4	194-195
61	11.5	188	502	4.1	1.6	33.0	10000	C512_33.0	— P80	— V 1 F	P80	BN80C2	194-195
63	12.0	180	480	2.8	1.0	15.8	6670	C412_15.8	V2 P90	V 2 C V 2 F	P90	BN90LA4	192-193
64	12.1	179	477	2.5	1.0	31.4	6660	C412_31.4	V1 P80	V 1 C V 1 F	P80	BN80C2	192-193
67	12.7	171	456	4.7	1.8	15.0	10000	C512_15.0	V2 P90	V 2 C V 2 F	P90	BN90LA4	194-195
68	12.8	169	450	2.3	0.8	14.8	5590	C352_14.8	— P90	— V 2 F	P90	BN90LA4	190-191
70	13.4	162	432	3.1	1.2	14.2	6490	C412_14.2	V2 P90	V 2 C V 2 F	P90	BN90LA4	192-193
76	14.5	149	398	5.4	2.0	13.1	10000	C512_13.1	V2 P90	V 2 C V 2 F	P90	BN90LA4	194-195
80	15.1	143	382	1.7	0.8	25.1	4670	C312_25.1	V1 P80	V 1 C V 1 F	P80	BN80C2	188-189
81	15.3	141	377	3.5	1.3	12.4	6270	C412_12.4	V2 P90	V 2 C V 2 F	P90	BN90LA4	192-193
93	17.6	108	236	3.8	2.1	7.1	6100	C412_7.1	V2 P90	V 2 C V 2 F	P90	BN100LA6R	192-193
95	18.1	120	319	3.2	1.2	10.5	5130	C352_10.5	— P90	— V 2 F	P90	BN90LA4	190-191
100	18.9	115	306	2.1	1.0	20.1	4430	C312_20.1	V1 P80	V 1 C V 1 F	P80	BN80C2	188-189
104	19.8	109	292	4.1	1.7	9.6	5860	C412_9.6	V2 P90	V 2 C V 2 F	P90	BN90LA4	192-193
105	20.0	108	289	3.5	1.3	19.0	5100	C352_19.0	V1 P80	V 1 C V 1 F	P80	BN80C2	190-191
108	20.4	106	283	2.5	1.1	9.3	4340	C312_9.3	— P90	— V 2 F	P90	BN90LA4	188-189
127	24.1	90	240	1.6	0.8	15.8	2710	C212_15.8	— P80	— V 1 F	P80	BN80C2	186-187
128	24.4	89	237	2.4	1.3	15.6	4150	C312_15.6	V1 P80	V 1 C V 1 F	P80	BN80C2	188-189
139	26.4	82	219	2.9	1.3	7.2	4060	C312_7.2	— P90	— V 2 F	P90	BN90LA4	188-189
141	26.8	81	216	5.1	2.3	7.1	5500	C412_7.1	V2 P90	V 2 C V 2 F	P90	BN90LA4	192-193
159	30	72	192	2.5	1.0	6.3	3840	C312_6.3	— P90	— V 2 F	P90	BN90LA4	188-189
163	31	70	187	2.8	1.6	12.3	3900	C312_12.3	V1 P80	V 1 C V 1 F	P80	BN80C2	188-189
167	32	68	182	3.8	1.4	6.0	5000	C412_6.0	V2 P90	V 2 C V 2 F	P90	BN90LA4	192-193
200	38	57	152	2.8	1.3	5.0	3610	C312_5.0	— P90	— V 2 F	P90	BN90LA4	188-189
206	39	55	147	2.1	1.4	9.7	2440	C212_9.7	— P80	— V 1 F	P80	BN80C2	186-187

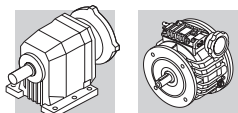

## 1.5 kW

$n_2$ min <sup>-1</sup>	$n_2'$ min <sup>-1</sup>	$M_2$ Nm	$M_2'$ Nm	<b>S</b>	<b>S'</b>	<b>i</b>	$R_{n2}$ N						
213	40	54	143	4.9	1.8	4.7	4670	<b>C412_4.7</b>	<b>V2</b> P90	<b>V 2 C</b> V 2 F	<b>P90</b>	<b>BN90LA4</b>	192-193
215	41	53	141	3.3	2.1	9.3	3610	<b>C312_9.3</b>	<b>V1</b> P80	<b>V 1 C</b> V 1 F	<b>P80</b>	<b>BN80C2</b>	188-189
278	53	41	109	3.9	2.6	7.2	3340	<b>C312_7.2</b>	<b>V1</b> P80	<b>V 1 C</b> V 1 F	<b>P80</b>	<b>BN80C2</b>	188-189
282	54	40	108	2.6	1.7	7.1	2270	<b>C212_7.1</b>	— P80	— V 1 F	<b>P80</b>	<b>BN80C2</b>	186-187
317	60	36	96	4.2	2.1	6.3	3240	<b>C312_6.3</b>	<b>V1</b> P80	<b>V 1 C</b> V 1 F	<b>P80</b>	<b>BN80C2</b>	188-189
328	62	35	93	2.4	1.3	6.1	2140	<b>C212_6.1</b>	— P80	— V 1 F	<b>P80</b>	<b>BN80C2</b>	186-187
417	79	27	73	2.9	1.4	4.8	2010	<b>C212_4.8</b>	— P80	— V 1 F	<b>P80</b>	<b>BN80C2</b>	186-187
541	103	21	56	3.3	1.9	3.7	1880	<b>C212_3.7</b>	— P80	— V 1 F	<b>P80</b>	<b>BN80C2</b>	186-187

## 1.85 kW

4.6	0.90	2811	7028	1.4	0.6	215.9	35000	<b>C803_215.9</b>	— P90	— V 2 F	<b>P90</b>	<b>BN90LB4</b>	200
5.1	1.0	2577	6442	1.5	0.6	197.9	35000	<b>C803_197.9</b>	— P90	— V 2 F	<b>P90</b>	<b>BN90LB4</b>	200
5.4	1.0	2401	6002	1.7	0.7	184.4	35000	<b>C803_184.4</b>	— P90	— V 2 F	<b>P90</b>	<b>BN90LB4</b>	200
5.9	1.1	2200	5501	1.8	0.7	169.0	35000	<b>C803_169.0</b>	— P90	— V 2 F	<b>P90</b>	<b>BN90LB4</b>	200
6.7	1.3	1941	4853	2.1	0.8	149.1	35000	<b>C803_149.1</b>	— P90	— V 2 F	<b>P90</b>	<b>BN90LB4</b>	200
7.3	1.4	1780	4450	2.2	0.9	136.7	35000	<b>C803_136.7</b>	— P90	— V 2 F	<b>P90</b>	<b>BN90LB4</b>	200
8.4	1.6	1556	3890	2.6	1.0	119.5	35000	<b>C803_119.5</b>	— P90	— V 2 F	<b>P90</b>	<b>BN90LB4</b>	200
9.1	1.7	1426	3564	2.8	1.1	109.5	35000	<b>C803_109.5</b>	— P90	— V 2 F	<b>P90</b>	<b>BN90LB4</b>	200
10.3	2.0	1268	3170	3.2	1.3	97.4	35000	<b>C803_97.4</b>	— P90	— V 2 F	<b>P90</b>	<b>BN90LB4</b>	200
11.2	2.1	1163	2907	3.4	1.4	89.3	35000	<b>C803_89.3</b>	— P90	— V 2 F	<b>P90</b>	<b>BN90LB4</b>	200
12.3	2.3	1060	2650	2.2	0.9	81.4	25000	<b>C703_81.4</b>	— P90	— V 2 F	<b>P90</b>	<b>BN90LB4</b>	198-199
14.0	2.7	928	2321	2.5	1.0	71.3	25000	<b>C703_71.3</b>	— P90	— V 2 F	<b>P90</b>	<b>BN90LB4</b>	198-199
14.2	2.7	918	2295	4.4	1.7	70.5	35000	<b>C803_70.5</b>	— P90	— V 2 F	<b>P90</b>	<b>BN90LB4</b>	200
15.2	2.9	858	2145	2.7	1.1	65.9	25000	<b>C703_65.9</b>	— P90	— V 2 F	<b>P90</b>	<b>BN90LB4</b>	198-199
16.0	3.0	814	2034	4.9	2.0	62.5	35000	<b>C803_62.5</b>	— P90	— V 2 F	<b>P90</b>	<b>BN90LB4</b>	200
17.5	3.3	746	1865	5.4	2.1	57.3	35000	<b>C803_57.3</b>	— P90	— V 2 F	<b>P90</b>	<b>BN90LB4</b>	200
17.7	3.4	736	1839	3.1	1.3	56.5	25000	<b>C703_56.5</b>	— P90	— V 2 F	<b>P90</b>	<b>BN90LB4</b>	198-199
18.7	3.6	697	1741	2.3	0.9	53.5	16000	<b>C613_53.5</b>	<b>V2</b> P90	<b>V 2 C</b> V 2 F	<b>P90</b>	<b>BN90LB4</b>	196-197
21.0	4.0	620	1549	2.6	1.0	47.6	16000	<b>C613_47.6</b>	<b>V2</b> P90	<b>V 2 C</b> V 2 F	<b>P90</b>	<b>BN90LB4</b>	196-197
22.4	4.3	582	1455	4.0	1.6	44.7	25000	<b>C703_44.7</b>	— P90	— V 2 F	<b>P90</b>	<b>BN90LB4</b>	198-199
24.2	4.6	538	1344	4.3	1.7	41.3	25000	<b>C703_41.3</b>	— P90	— V 2 F	<b>P90</b>	<b>BN90LB4</b>	198-199
26.3	5.0	505	1264	2.7	1.1	38.0	16000	<b>C612_38.0</b>	<b>V2</b> P90	<b>V 2 C</b> V 2 F	<b>P90</b>	<b>BN90LB4</b>	196-197
33	6.3	404	1011	3.3	1.3	30.4	16000	<b>C612_30.4</b>	<b>V2</b> P90	<b>V 2 C</b> V 2 F	<b>P90</b>	<b>BN90LB4</b>	196-197
39	7.3	344	861	2.3	0.9	25.9	10000	<b>C512_25.9</b>	<b>V2</b> P90	<b>V 2 C</b> V 2 F	<b>P90</b>	<b>BN90LB4</b>	194-195

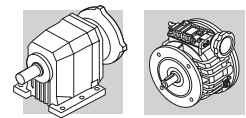

## 1.85 kW





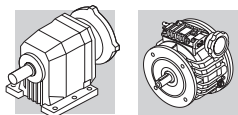

$n_2$ min <sup>-1</sup>	$n_2'$ min <sup>-1</sup>	$M_2$ Nm	$M_2'$ Nm	<b>S</b>	<b>S'</b>	<b>i</b>	$R_{n2}$ N					IEC	
40	7.7	330	825	4.1	1.6	24.8	16000	<b>C612_24.8</b>	<b>V2</b> P90	<b>V 2 C</b> V 2 F	<b>P90</b>	<b>BN90LB4</b>	196-197
48	9.0	279	698	2.9	1.1	21.0	10000	<b>C512_21.0</b>	<b>V2</b> P90	<b>V 2 C</b> V 2 F	<b>P90</b>	<b>BN90LB4</b>	194-195
51	9.6	263	658	1.9	0.8	19.8	6840	<b>C412_19.8</b>	<b>V2</b> P90	<b>V 2 C</b> V 2 F	<b>P90</b>	<b>BN90LB4</b>	192-193
51	9.7	261	652	5.2	2.1	19.6	16000	<b>C612_19.6</b>	<b>V2</b> P90	<b>V 2 C</b> V 2 F	<b>P90</b>	<b>BN90LB4</b>	196-197
60	11.4	221	552	3.6	1.4	16.6	10000	<b>C512_16.6</b>	<b>V2</b> P90	<b>V 2 C</b> V 2 F	<b>P90</b>	<b>BN90LB4</b>	194-195
63	11.9	211	529	6.4	2.6	15.9	16000	<b>C612_15.9</b>	<b>V2</b> P90	<b>V 2 C</b> V 2 F	<b>P90</b>	<b>BN90LB4</b>	196-197
63	12.0	210	525	2.4	1.0	15.8	6520	<b>C412_15.8</b>	<b>V2</b> P90	<b>V 2 C</b> V 2 F	<b>P90</b>	<b>BN90LB4</b>	192-193
76	14.5	174	436	4.6	1.8	13.1	10000	<b>C512_13.1</b>	<b>V2</b> P90	<b>V 2 C</b> V 2 F	<b>P90</b>	<b>BN90LB4</b>	194-195
81	15.3	165	412	3.0	1.2	12.4	6160	<b>C412_12.4</b>	<b>V2</b> P90	<b>V 2 C</b> V 2 F	<b>P90</b>	<b>BN90LB4</b>	192-193
102	19.4	130	326	6.1	2.5	9.8	10000	<b>C512_9.8</b>	<b>V2</b> P90	<b>V 2 C</b> V 2 F	<b>P90</b>	<b>BN90LB4</b>	194-195
104	19.8	128	319	3.5	1.6	9.6	5770	<b>C412_9.6</b>	<b>V2</b> P90	<b>V 2 C</b> V 2 F	<b>P90</b>	<b>BN90LB4</b>	192-193
108	20.4	124	309	2.1	1.0	9.3	4250	<b>C312_9.3</b>	— P90	— V 2 F	<b>P90</b>	<b>BN90LB4</b>	188-189
139	26.4	96	239	2.5	1.2	7.2	3990	<b>C312_7.2</b>	— P90	— V 2 F	<b>P90</b>	<b>BN90LB4</b>	188-189
141	26.8	94	236	4.4	2.1	7.1	5320	<b>C412_7.1</b>	<b>V2</b> P90	<b>V 2 C</b> V 2 F	<b>P90</b>	<b>BN90LB4</b>	192-193
159	30	84	209	2.1	1.0	6.3	3770	<b>C312_6.3</b>	— P90	— V 2 F	<b>P90</b>	<b>BN90LB4</b>	188-189
167	32	80	200	3.3	1.3	6.0	4920	<b>C412_6.0</b>	<b>V2</b> P90	<b>V 2 C</b> V 2 F	<b>P90</b>	<b>BN90LB4</b>	192-193
200	38	67	166	2.4	1.2	5.0	3550	<b>C312_5.0</b>	— P90	— V 2 F	<b>P90</b>	<b>BN90LB4</b>	188-189
213	40	63	156	4.2	1.7	4.7	4610	<b>C412_4.7</b>	<b>V2</b> P90	<b>V 2 C</b> V 2 F	<b>P90</b>	<b>BN90LB4</b>	192-193
270	51	49	123	3.1	1.4	3.7	3300	<b>C312_3.7</b>	— P90	— V 2 F	<b>P90</b>	<b>BN90LB4</b>	188-189
345	66	39	96	3.9	1.6	2.9	3070	<b>C312_2.9</b>	— P90	— V 2 F	<b>P90</b>	<b>BN90LB4</b>	188-189

## 2.2 kW

3.9	0.70	3841	8963	1.9	0.8	172.1	60000	<b>C903_172.1</b>	— P100	— V 3 F	<b>P100</b>	<b>BN112M6</b>	201
4.2	0.80	3522	8218	2.0	0.9	157.8	60000	<b>C903_157.8</b>	— P100	— V 3 F	<b>P100</b>	<b>BN112M6</b>	201
4.9	0.90	3051	7119	1.3	0.6	136.7	35000	<b>C803_136.7</b>	— P100	— V 3 F	<b>P100</b>	<b>BN112M6</b>	200
4.9	0.90	2993	6984	2.4	1.0	134.1	60000	<b>C903_134.1</b>	— P100	— V 3 F	<b>P100</b>	<b>BN112M6</b>	201
5.5	1.0	2667	6224	1.5	0.6	119.5	35000	<b>C803_119.5</b>	— P100	— V 3 F	<b>P100</b>	<b>BN112M6</b>	200
5.8	1.1	2561	6402	2.8	1.1	172.1	60000	<b>C903_172.1</b>	— P100	— V 3 F	<b>P100</b>	<b>BN100LA4</b>	201
6.1	1.1	2444	5703	1.6	0.7	109.5	35000	<b>C803_109.5</b>	— P100	— V 3 F	<b>P100</b>	<b>BN112M6</b>	200
6.3	1.2	2348	5870	3.0	1.2	157.8	60000	<b>C903_157.8</b>	— P100	— V 3 F	<b>P100</b>	<b>BN100LA4</b>	201
6.8	1.3	2174	5073	1.8	0.8	97.4	35000	<b>C803_97.4</b>	— P100	— V 3 F	<b>P100</b>	<b>BN112M6</b>	200
6.8	1.3	2201	5442	3.3	1.3	146.3	60000	<b>C903_146.3</b>	— P100	— V 3 F	<b>P100</b>	<b>BN100LA4</b>	201
7.3	1.4	2034	5085	2.0	0.8	136.7	35000	<b>C803_136.7</b>	— P100	— V 3 F	<b>P100</b>	<b>BN100LA4</b>	200







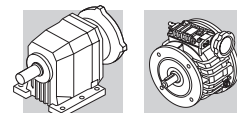

## 2.2 kW

$n_2$ min <sup>-1</sup>	$n_2'$ min <sup>-1</sup>	$M_2$ Nm	$M_2'$ Nm	S	S'	i	R <sub>n2</sub> N						
7.4	1.4	1993	4651	2.0	0.9	89.3	35000	<b>C803_89.3</b>	— P100	— V 3 F	<b>P100</b>	<b>BN112M6</b>	200
7.5	1.4	1995	4989	3.6	1.4	134.1	60000	<b>C903_134.1</b>	— P100	— V 3 F	<b>P100</b>	<b>BN100LA4</b>	201
8.1	1.5	1817	4239	1.3	0.5	81.4	25000	<b>C703_81.4</b>	<b>V3</b> P100	<b>V 3 C</b> V 3 F	<b>P100</b>	<b>BN112M6</b>	198-199
8.4	1.6	1778	4445	2.2	0.9	119.5	35000	<b>C803_119.5</b>	— P100	— V 3 F	<b>P100</b>	<b>BN100LA4</b>	200
8.6	1.6	1716	4005	2.3	1.0	76.9	35000	<b>C803_76.9</b>	— P100	— V 3 F	<b>P100</b>	<b>BN112M6</b>	200
9.1	1.7	1629	4073	2.5	1.0	109.5	35000	<b>C803_109.5</b>	— P100	— V 3 F	<b>P100</b>	<b>BN100LA4</b>	200
9.3	1.8	1591	3713	1.4	0.6	71.3	25000	<b>C703_71.3</b>	<b>V3</b> P100	<b>V 3 C</b> V 3 F	<b>P100</b>	<b>BN112M6</b>	198-199
9.3	1.8	1592	3980	4.5	1.8	107.0	60000	<b>C903_107.0</b>	— P100	— V 3 F	<b>P100</b>	<b>BN100LA4</b>	201
10.1	1.9	1471	3432	1.6	0.7	65.9	25000	<b>C703_65.9</b>	<b>V3</b> P100	<b>V 3 C</b> V 3 F	<b>P100</b>	<b>BN112M6</b>	198-199
10.3	2.0	1449	3623	2.8	1.1	97.4	35000	<b>C803_97.4</b>	— P100	— V 3 F	<b>P100</b>	<b>BN100LA4</b>	200
10.4	2.0	1431	3579	5.0	2.0	96.2	60000	<b>C903_96.2</b>	— P100	— V 3 F	<b>P100</b>	<b>BN100LA4</b>	201
11.2	2.1	1329	3322	3.0	1.2	89.3	35000	<b>C803_89.3</b>	— P100	— V 3 F	<b>P100</b>	<b>BN100LA4</b>	200
11.3	2.2	1312	3281	1.8	0.7	88.2	25000	<b>C703_88.2</b>	<b>V3</b> P100	<b>V 3 C</b> V 3 F	<b>P100</b>	<b>BN100LA4</b>	198-199
11.7	2.2	1261	2943	1.8	0.8	56.5	25000	<b>C703_56.5</b>	<b>V3</b> P100	<b>V 3 C</b> V 3 F	<b>P100</b>	<b>BN112M6</b>	198-199
12.3	2.3	1211	3028	1.9	0.8	81.4	25000	<b>C703_81.4</b>	<b>V3</b> P100	<b>V 3 C</b> V 3 F	<b>P100</b>	<b>BN100LA4</b>	198-199
12.7	2.4	1165	2719	2.0	0.8	52.2	25000	<b>C703_52.2</b>	<b>V3</b> P100	<b>V 3 C</b> V 3 F	<b>P100</b>	<b>BN112M6</b>	198-199
13.0	2.5	1144	2861	3.5	1.4	76.9	35000	<b>C803_76.9</b>	— P100	— V 3 F	<b>P100</b>	<b>BN100LA4</b>	200
14.0	2.7	1061	2652	2.2	0.9	71.3	25000	<b>C703_71.3</b>	<b>V3</b> P100	<b>V 3 C</b> V 3 F	<b>P100</b>	<b>BN100LA4</b>	198-199
14.2	2.7	1049	2623	3.8	1.5	70.5	35000	<b>C803_70.5</b>	— P100	— V 3 F	<b>P100</b>	<b>BN100LA4</b>	200
14.8	2.8	998	2328	2.3	1.0	44.7	25000	<b>C703_44.7</b>	<b>V3</b> P100	<b>V 3 C</b> V 3 F	<b>P100</b>	<b>BN112M6</b>	198-199
15.2	2.9	981	2451	2.3	0.9	65.9	25000	<b>C703_65.9</b>	<b>V3</b> P100	<b>V 3 C</b> V 3 F	<b>P100</b>	<b>BN100LA4</b>	198-199
16.0	3.0	930	2325	4.3	1.7	62.5	35000	<b>C803_62.5</b>	— P100	— V 3 F	<b>P100</b>	<b>BN100LA4</b>	200
16.1	3.0	922	2151	2.5	1.1	41.3	25000	<b>C703_41.3</b>	<b>V3</b> P100	<b>V 3 C</b> V 3 F	<b>P100</b>	<b>BN112M6</b>	198-199
17.1	3.2	872	2180	1.8	0.7	58.6	16000	<b>C613_58.6</b>	<b>V3</b> P100	<b>V 3 C</b> V 3 F	<b>P100</b>	<b>BN100LA4</b>	196-197
17.5	3.3	853	2132	4.7	1.9	57.3	35000	<b>C803_57.3</b>	— P100	— V 3 F	<b>P100</b>	<b>BN100LA4</b>	200
17.7	3.4	841	2102	2.7	1.1	56.5	25000	<b>C703_56.5</b>	<b>V3</b> P100	<b>V 3 C</b> V 3 F	<b>P100</b>	<b>BN100LA4</b>	198-199
19.1	3.6	791	1846	2.7	1.1	34.7	25000	<b>C702_34.7</b>	<b>V3</b> P100	<b>V 3 C</b> V 3 F	<b>P100</b>	<b>BN112M6</b>	198-199
19.2	3.6	777	1942	3.0	1.2	52.2	25000	<b>C703_52.2</b>	<b>V3</b> P100	<b>V 3 C</b> V 3 F	<b>P100</b>	<b>BN100LA4</b>	198-199
21.0	4.0	708	177	2.3	0.9	47.6	16000	<b>C613_47.6</b>	<b>V3</b> P100	<b>V 3 C</b> V 3 F	<b>P100</b>	<b>BN100LA4</b>	196-197
21.1	4.0	705	2003	5.7	2.3	47.4	35000	<b>C803_47.4</b>	— P100	— V 3 F	<b>P100</b>	<b>BN100LA4</b>	200
22.4	4.3	665	1663	3.5	1.4	44.7	25000	<b>C703_44.7</b>	<b>V3</b> P100	<b>V 3 C</b> V 3 F	<b>P100</b>	<b>BN100LA4</b>	198-199
23.9	4.5	632	1474	3.3	1.4	27.7	25000	<b>C702_27.7</b>	<b>V3</b> P100	<b>V 3 C</b> V 3 F	<b>P100</b>	<b>BN112M6</b>	198-199
24.2	4.6	615	1536	3.7	1.5	41.3	25000	<b>C703_41.3</b>	<b>V3</b> P100	<b>V 3 C</b> V 3 F	<b>P100</b>	<b>BN100LA4</b>	198-199
26.3	5.0	578	1444	2.3	0.9	38.0	16000	<b>C612_38.0</b>	<b>V3</b> P100	<b>V 3 C</b> V 3 F	<b>P100</b>	<b>BN100LA4</b>	196-197







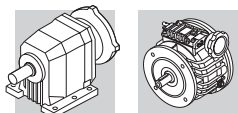

## 2.2 kW

$n_2$ min <sup>-1</sup>	$n_2'$ min <sup>-1</sup>	M <sub>2</sub> Nm	M <sub>2'</sub> Nm	S	S'	i	R <sub>n2</sub> N					IEC 	
27.0	5.1	551	1376	1.8	0.7	37.0	10000	<b>C513_37.0</b>	V3 P100	V 3 C V 3 F	P100	BN100LA4	194-195
28.8	5.5	527	1319	4.0	1.6	34.7	25000	<b>C702_34.7</b>	V3 P100	V 3 C V 3 F	P100	BN100LA4	198-199
29.2	5.6	520	1300	2.4	1.0	34.2	16000	<b>C612_34.2</b>	V3 P100	V 3 C V 3 F	P100	BN100LA4	196-197
32	6.0	479	1117	1.7	0.7	21.0	10000	<b>C512_21.0</b>	V3 P100	V 3 C V 3 F	P112	BN112M6	194-195
33	6.3	462	1155	2.9	1.2	30.4	16000	<b>C612_30.4</b>	V3 P100	V 3 C V 3 F	P100	BN100LA4	196-197
33	6.3	448	1120	2.2	0.9	30.1	10000	<b>C513_30.1</b>	V3 P100	V 3 C V 3 F	P100	BN100LA4	194-195
36	6.9	421	1053	5.0	2.0	27.7	25000	<b>C702_27.7</b>	V3 P100	V 3 C V 3 F	P100	BN100LA4	198-199
36	6.9	408	1019	2.5	1.0	27.4	10000	<b>C513_27.4</b>	V3 P100	V 3 C V 3 F	P100	BN100LA4	194-195
40	7.7	377	942	3.6	1.4	24.8	16000	<b>C612_24.8</b>	V3 P100	V 3 C V 3 F	P100	BN100LA4	196-197
43	8.1	356	889	2.2	0.9	23.4	10000	<b>C512_23.4</b>	V3 P100	V 3 C V 3 F	P100	BN100LA4	194-195
51	9.7	298	745	4.5	1.8	19.6	16000	<b>C612_19.6</b>	V3 P100	V 3 C V 3 F	P100	BN100LA4	196-197
53	10.1	287	718	2.8	1.1	18.9	10000	<b>C512_18.9</b>	V3 P100	V 3 C V 3 F	P100	BN100LA4	194-195
56	10.7	271	676	1.8	0.7	17.8	6500	<b>C412_17.8</b>	— P100	— V 3 F	P100	BN100LA4	192-193
60	11.4	252	631	3.2	1.3	16.6	10000	<b>C512_16.6</b>	V3 P100	V 3 C V 3 F	P100	BN100LA4	194-195
63	12.0	240	600	2.1	0.8	15.8	6370	<b>C412_15.8</b>	— P100	— V 3 F	P100	BN100LA4	192-193
76	14.5	199	498	4.0	1.6	13.1	10000	<b>C512_13.1</b>	V3 P100	V 3 C V 3 F	P100	BN100LA4	194-195
81	15.3	188	471	2.6	1.1	12.4	6040	<b>C412_12.4</b>	— P100	— V 3 F	P100	BN100LA4	192-193
89	17.0	170	426	2.9	1.2	11.2	5880	<b>C412_11.2</b>	— P100	— V 3 F	P100	BN100LA4	192-193
95	18.1	160	399	2.4	1.0	10.5	4930	<b>C352_10.5</b>	— P100	— V 3 F	P100	BN100LA4	190-191
102	19.4	149	372	5.4	2.1	9.8	10000	<b>C512_9.8</b>	V3 P100	V 3 C V 3 F	P100	BN100LA4	194-195
114	21.6	134	334	2.8	1.1	8.8	4740	<b>C352_8.8</b>	— P100	— V 3 F	P100	BN100LA4	190-191
127	24.1	120	300	3.2	1.3	7.9	4610	<b>C352_7.9</b>	— P100	— V 3 F	P100	BN100LA4	190-191
128	24.4	119	296	6.2	2.7	7.8	10000	<b>C512_7.8</b>	V3 P100	V 3 C V 3 F	P100	BN100LA4	194-195
141	26.8	108	270	3.8	1.9	7.1	5250	<b>C412_7.1</b>	— P100	— V 3 F	P100	BN100LA4	192-193
156	29.7	97	243	4.1	2.0	6.4	5100	<b>C412_6.4</b>	— P100	— V 3 F	P100	BN100LA4	192-193
164	31	93	232	4.1	1.6	6.1	4310	<b>C352_6.1</b>	— P100	— V 3 F	P100	BN100LA4	190-191
179	34	85	213	5.1	2.0	5.6	10000	<b>C512_5.6</b>	V3 P100	V 3 C V 3 F	P100	BN100LA4	194-195
213	40	71	179	3.6	1.5	4.7	4550	<b>C412_4.7</b>	— P100	— V 3 F	P100	BN100LA4	192-193
217	41	70	175	2.9	1.1	4.6	3930	<b>C352_4.6</b>	— P100	— V 3 F	P100	BN100LA4	190-191
278	53	55	137	4.7	1.9	3.6	4250	<b>C412_3.6</b>	— P100	— V 3 F	P100	BN100LA4	192-193
303	58	50	125	8.4	3.3	3.3	10000	<b>C512_3.3</b>	V3 P100	V 3 C V 3 F	P100	BN100LA4	194-195
370	70	41	103	4.6	1.9	2.7	3390	<b>C352_2.7</b>	— P100	— V 3 F	P100	BN100LA4	190-191







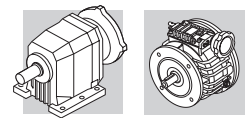

## 3 kW

$n_2$ min <sup>-1</sup>	$n_2'$ min <sup>-1</sup>	$M_2$ Nm	$M_2'$ Nm	S	S'	i	$R_{n2}$ N					IEC 	
5.8	1.1	3841	8963	1.9	0.8	172.1	60000	C903_172.1	— P100	— V 3 F	P100	BN100LB4	201
6.3	1.2	3522	8218	2.0	0.9	157.8	60000	C903_157.8	— P100	— V 3 F	P100	BN100LB4	201
6.8	1.3	3265	7619	2.2	0.9	146.3	60000	C903_146.3	— P100	— V 3 F	P100	BN100LB4	201
7.5	1.4	2993	6984	2.4	1.0	134.1	60000	C903_134.1	— P100	— V 3 F	P100	BN100LB4	201
8.6	1.6	2605	6078	2.8	1.2	116.7	60000	C903_116.7	— P100	— V 3 F	P100	BN100LB4	201
9.1	1.7	2444	5703	1.6	0.7	109.5	35000	C803_109.5	— P100	— V 3 F	P100	BN100LB4	200
9.3	1.8	2388	5573	3.0	1.3	107.0	60000	C903_107.0	— P100	— V 3 F	P100	BN100LB4	201
10.4	2.0	2147	5010	3.4	1.4	96.2	60000	C903_96.2	— P100	— V 3 F	P100	BN100LB4	201
11.2	2.1	1993	4651	2.0	0.9	89.3	35000	C803_89.3	— P100	— V 3 F	P100	BN100LB4	200
11.3	2.2	1969	4593	3.6	1.5	88.2	60000	C903_88.2	— P100	— V 3 F	P100	BN100LB4	201
12.3	2.3	1817	4239	1.3	0.5	81.4	25000	C703_81.4	V3 P100	V 3 C V 3 F	P100	BN100LB4	198-199
13.0	2.5	1716	4005	2.3	1.0	76.9	35000	C803_76.9	— P100	— V 3 F	P100	BN100LB4	200
14.0	2.7	1591	3713	1.4	0.6	71.3	25000	C703_71.3	V3 P100	V 3 C V 3 F	P100	BN100LB4	198-199
14.2	2.7	1574	3672	2.5	1.1	70.5	35000	C803_70.5	— P100	— V 3 F	P100	BN100LB4	200
15.2	2.9	1471	3432	1.6	0.7	65.9	25000	C703_65.9	V3 P100	V 3 C V 3 F	P100	BN100LB4	198-199
16.0	3.0	1395	3255	2.9	1.2	62.5	35000	C803_62.5	— P100	— V 3 F	P100	BN100LB4	200
17.7	3.4	1261	2943	1.8	0.8	56.5	25000	C703_56.5	V3 P100	V 3 C V 3 F	P100	BN100LB4	198-199
19.2	3.6	1165	2719	2.0	0.8	52.2	25000	C703_52.2	V3 P100	V 3 C V 3 F	P100	BN100LB4	198-199
21.1	4.0	1058	2469	3.8	1.6	47.4	35000	C803_47.4	— P100	— V 3 F	P100	BN100LB4	200
22.4	4.3	998	2328	2.3	1.0	44.7	25000	C703_44.7	V3 P100	V 3 C V 3 F	P100	BN100LB4	198-199
24.2	4.6	922	2151	2.5	1.1	41.3	25000	C703_41.3	V3 P100	V 3 C V 3 F	P100	BN100LB4	198-199
26.3	5.0	866	2022	1.6	0.7	38.0	16000	C612_38.0	V3 P100	V 3 C V 3 F	P100	BN100LB4	196-197
28.8	5.5	791	1846	2.7	1.1	34.7	25000	C702_34.7	V3 P100	V 3 C V 3 F	P100	BN100LB4	198-199
29.2	5.6	780	1819	1.6	0.7	34.2	16000	C612_34.2	V3 P100	V 3 C V 3 F	P100	BN100LB4	196-197
33	6.3	693	1617	1.9	0.8	30.4	16000	C612_30.4	V3 P100	V 3 C V 3 F	P100	BN100LB4	196-197
36	6.9	632	1474	3.3	1.4	27.7	25000	C702_27.7	V3 P100	V 3 C V 3 F	P100	BN100LB4	198-199
40	7.7	565	1319	2.4	1.0	24.8	16000	C612_24.8	V3 P100	V 3 C V 3 F	P100	BN100LB4	196-197
44	8.3	522	1218	4.0	1.7	22.9	25000	C702_22.9	V3 P100	V 3 C V 3 F	P100	BN100LB4	198-199
48	9.0	479	1117	1.7	0.7	21.0	10000	C512_21.0	V3 P100	V 3 C V 3 F	P100	BN100LB4	194-195
51	9.7	447	1043	3.0	1.3	19.6	15800	C612_19.6	V3 P100	V 3 C V 3 F	P100	BN100LB4	196-197
52	9.8	440	1027	4.8	2.0	19.3	25000	C702_19.3	V3 P100	V 3 C V 3 F	P100	BN100LB4	198-199
60	11.4	378	883	2.1	0.9	16.6	10000	C512_16.6	V3 P100	V 3 C V 3 F	P100	BN100LB4	194-195
63	11.9	363	846	3.7	1.6	15.9	14900	C612_15.9	V3 P100	V 3 C V 3 F	P100	BN100LB4	196-197
63	12.0	360	841	1.4	0.6	15.8	5770	C412_15.8	— P100	— V 3 F	P100	BN100LB4	192-193





## 3 kW





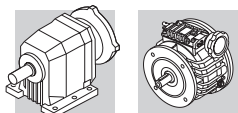

$n_2$ min <sup>-1</sup>	$n_2'$ min <sup>-1</sup>	M <sub>2</sub> Nm	M <sub>2'</sub> Nm	S	S'	i	R <sub>n2</sub> N					IEC 	
76	14.5	299	697	2.7	1.1	13.1	10000	C512_13.1	V3 P100	V 3 C V 3 F	P100	BN100LB4	194-195
81	15.3	283	660	1.8	0.8	12.4	5570	C412_12.4	— P100	— V 3 F	P100	BN100LB4	192-193
85	16.2	267	622	1.4	0.6	11.7	4630	C352_11.7	— P100	— V 3 F	P100	BN100LB4	190-191
102	19.4	223	521	3.6	1.5	9.8	9460	C512_9.8	V3 P100	V 3 C V 3 F	P100	BN100LB4	194-195
104	19.8	219	511	2.1	1.0	9.6	5320	C412_9.6	— P100	— V 3 F	P100	BN100LB4	192-193
114	21.6	201	468	1.9	0.8	8.8	4410	C352_8.8	— P100	— V 3 F	P100	BN100LB4	190-191
141	26.8	162	378	2.6	1.3	7.1	4980	C412_7.1	— P100	— V 3 F	P100	BN100LB4	192-193
143	27.1	160	372	4.6	2.1	7.0	8610	C512_7.0	V3 P100	V 3 C V 3 F	P100	BN100LB4	194-195
147	27.9	155	362	2.5	1.1	6.8	4190	C352_6.8	— P100	— V 3 F	P100	BN100LB4	190-191
167	32	137	319	1.9	0.8	6.0	4530	C412_6.0	— P100	— V 3 F	P100	BN100LB4	192-193
179	34	128	298	3.4	1.5	5.6	7980	C512_5.6	V3 P100	V 3 C V 3 F	P100	BN100LB4	194-195
213	40	107	250	2.4	1.0	4.7	4310	C412_4.7	— P100	— V 3 F	P100	BN100LB4	192-193
217	41	105	245	1.9	0.8	4.6	3720	C352_4.6	— P100	— V 3 F	P100	BN100LB4	190-191
222	42	103	239	4.2	1.8	4.5	7450	C512_4.5	V3 P100	V 3 C V 3 F	P100	BN100LB4	194-195
278	53	82	192	3.1	1.3	3.6	4060	C412_3.6	— P100	— V 3 F	P100	BN100LB4	192-193
286	54	80	186	2.5	1.1	3.5	3480	C352_3.5	— P100	— V 3 F	P100	BN100LB4	190-191
303	58	75	176	5.6	2.4	3.3	7000	C512_3.3	V3 P100	V 3 C V 3 F	P100	BN100LB4	194-195
370	70	62	144	3.1	1.4	2.7	3260	C352_2.7	— P100	— V 3 F	P100	BN100LB4	190-191

## 4 kW

3.9	0.70	6882	13765	1.0	0.5	172.1	60000	C903_172.1	— P132	— V 10 F	P132	BN132MA6	201
4.2	0.80	6310	12621	1.1	0.6	157.8	60000	C903_157.8	— P132	— V 10 F	P132	BN132MA6	201
4.5	0.90	5851	11701	1.2	0.6	146.3	60000	C903_146.3	— P132	— V 10 F	P132	BN132MA6	201
4.9	0.90	5363	10725	1.3	0.7	134.1	60000	C903_134.1	— P132	— V 10 F	P132	BN132MA6	201
5.8	1.1	5122	11524	1.4	0.6	172.1	60000	C903_172.1	— P112	— V 5.5 F	P112	BN112M4	201
6.2	1.2	4279	8558	1.7	0.8	107.0	60000	C903_107.0	— P132	— V 10 F	P132	BN132MA6	201
6.3	1.2	4696	10566	1.5	0.7	157.8	60000	C903_157.8	— P112	— V 5.5 F	P112	BN112M4	201
6.8	1.3	4354	9796	1.7	0.7	146.3	60000	C903_146.3	— P112	— V 5.5 F	P112	BN112M4	201
7.5	1.4	3991	8979	1.8	0.8	134.1	60000	C903_134.1	— P112	— V 5.5 F	P112	BN112M4	201
7.5	1.4	3527	7054	2.0	1.0	88.2	60000	C903_88.2	— P132	— V 10 F	P132	BN132MA6	201
8.2	1.5	3247	6494	2.2	1.1	81.2	60000	C903_81.2	— P132	— V 10 F	P132	BN132MA6	201
8.4	1.6	3556	8002	1.1	0.5	119.5	35000	C803_119.5	— P112	— V 5.5 F	P112	BN112M4	200







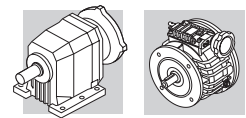

## 4 kW

$n_2$ min <sup>-1</sup>	$n_2'$ min <sup>-1</sup>	$M_2$ Nm	$M_2'$ Nm	S	S'	i	R <sub>n2</sub> N					IEC 	
8.6	1.6	3473	7814	2.1	0.9	116.7	60000	C903_116.7	—	—	P112	BN112M4	201
9.1	1.7	3259	7332	1.2	0.5	109.5	35000	C803_109.5	—	—	P112	BN112M4	200
9.3	1.8	3184	7165	2.2	1.0	107.0	60000	C903_107.0	—	—	P112	BN112M4	201
9.4	1.8	2819	5639	1.4	0.7	70.5	35000	C803_70.5	—	—	P132	BN132MA6	200
10.3	2.0	2899	6522	1.4	0.6	97.4	35000	C803_97.4	—	—	P112	BN112M4	200
10.4	2.0	2863	6442	2.5	1.1	96.2	60000	C903_96.2	—	—	P112	BN112M4	201
10.6	2.0	2499	4999	1.6	0.8	62.5	35000	C803_62.5	—	—	P132	BN132MA6	200
11.2	2.1	2658	5980	1.5	0.7	89.3	35000	C803_89.3	—	—	P112	BN112M4	200
11.3	2.2	2625	5906	2.7	1.2	88.2	60000	C903_88.2	—	—	P112	BN112M4	201
11.6	2.2	2291	4583	1.7	0.9	57.3	35000	C803_57.3	—	—	P132	BN132MA6	200
12.3	2.3	2417	5437	3.0	1.3	81.2	60000	C903_81.2	—	—	P112	BN112M4	201
13.0	2.5	2289	5149	1.7	0.8	76.9	35000	C803_76.9	—	—	P112	BN112M4	200
13.4	2.6	2214	4982	3.2	1.4	74.4	60000	C903_74.4	—	—	P112	BN112M4	201
14.0	2.7	2122	4774	1.1	0.5	71.3	25000	C703_71.3	V55 P112	V 5.5 C V 5.5 F	P112	BN112M4	198-199
14.2	2.7	2098	4721	1.9	0.8	70.5	35000	C803_70.5	—	—	P112	BN112M4	200
15.2	2.9	1961	4413	1.2	0.5	65.9	25000	C703_65.9	V55 P112	V 5.5 C V 5.5 F	P112	BN112M4	198-199
16.0	3.0	1860	4185	2.2	1.0	62.5	35000	C803_62.5	—	—	P112	BN112M4	200
16.1	3.0	1652	3303	1.4	0.7	41.3	25000	C703_41.3	—	—	P132	BN132MA6	198-199
17.0	3.2	1597	3194	2.0	1.0	39.1	35000	C802_39.1	—	—	P132	BN132MA6	200
17.5	3.3	1705	3837	2.3	1.0	57.3	35000	C803_57.3	—	—	P112	BN112M4	200
17.7	3.4	1681	3783	1.4	0.6	56.5	25000	C703_56.5	V55 P112	V 5.5 C V 5.5 F	P112	BN112M4	198-199
19.1	3.6	1417	2835	1.5	0.7	34.7	25000	C702_34.7	—	—	P132	BN132MA6	198-199
19.2	3.6	1553	3495	1.5	0.7	52.2	25000	C703_52.2	V55 P112	V 5.5 C V 5.5 F	P112	BN112M4	198-199
21.1	4.0	1411	3174	2.8	1.3	47.4	35000	C803_47.4	—	—	P112	BN112M4	200
22.4	4.3	1330	2993	1.7	0.8	44.7	25000	C703_44.7	V55 P112	V 5.5 C V 5.5 F	P112	BN112M4	198-199
23.0	4.4	1295	2913	3.1	1.4	43.5	35000	C803_43.5	—	—	P112	BN112M4	200
23.9	4.5	1132	2263	1.9	0.9	27.7	25000	C702_27.7	—	—	P132	BN132MA6	198-199
24.2	4.6	1229	2765	1.9	0.8	41.3	25000	C703_41.3	V55 P112	V 5.5 C V 5.5 F	P112	BN112M4	198-199
25.6	4.9	1189	2674	2.7	1.2	39.1	35000	C802_39.1	—	—	P112	BN112M4	200
27.6	5.2	980	1961	3.6	1.8	24.0	35000	C802_24.0	—	—	P132	BN132MA6	200
28.8	5.5	1055	2373	2.0	0.9	34.7	25000	C702_34.7	V55 P112	V 5.5 C V 5.5 F	P112	BN112M4	198-199
29.0	5.5	935	1871	2.2	1.1	22.9	25000	C702_22.9	—	—	P132	BN132MA6	198-199
32	6.1	952	2141	3.9	1.7	31.3	35000	C802_31.3	—	—	P112	BN112M4	200
34	6.4	1173	2160	1.2	0.6	19.6	16000	C612_19.6	V10 P132	V 10 C V 10 F	P132	BN132MA6	196-197







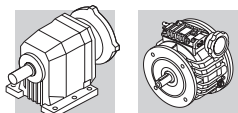

## 4 kW

$n_2$ min <sup>-1</sup>	$n_2'$ min <sup>-1</sup>	M <sub>2</sub> Nm	M <sub>2'</sub> Nm	S	S'	i	Rn <sub>2</sub> N					IEC 	
34	6.5	788	1577	2.7	1.3	19.3	25000	C702_19.3	— P132	— V 10 F	P132	BN132MA6	198-199
36	6.9	842	1895	2.5	1.1	27.7	25000	C702_27.7	V55 P112	V 5.5 C V 5.5 F	P112	BN112M4	198-199
39	7.3	787	1772	4.7	2.1	25.9	35000	C802_25.9	— P112	— V 5.5 F	P112	BN112M4	200
42	7.9	952	1752	1.4	0.8	15.9	16000	C612_15.9	V10 P132	V 10 C V 10 F	P132	BN132MA6	196-197
43	8.2	625	1250	3.4	1.7	15.3	25000	C702_15.3	— P132	— V 10 F	P132	BN132MA6	198-199
44	8.3	696	1566	3.0	1.3	22.9	25000	C702_22.9	V55 P112	V 5.5 C V 5.5 F	P112	BN112M4	198-199
47	8.9	576	1152	3.7	1.9	14.1	25000	C702_14.1	— P132	— V 10 F	P132	BN132MA6	198-199
51	9.7	596	134	2.3	1.0	19.6	15300	C612_19.6	V55 P112	V 5.5 C V 5.5 F	P112	BN112M4	196-197
52	9.8	587	1320	3.6	1.6	19.3	25000	C702_19.3	V55 P112	V 5.5 C V 5.5 F	P112	BN112M4	198-199
55	10.3	724	1333	1.9	1.0	12.1	15200	C612_12.1	V10 P132	V 10 C V 10 F	P132	BN132MA6	196-197
60	11.4	505	1135	1.6	0.7	16.6	10000	C512_16.6	V55 P112	V 5.5 C V 5.5 F	P112	BN112M4	194-195
61	11.5	652	1201	2.1	1.1	10.9	14800	C612_10.9	V10 P132	V 10 C V 10 F	P132	BN132MA6	196-197
68	12.8	587	1080	2.3	1.3	9.8	14400	C612_9.8	V10 P132	V 10 C V 10 F	P132	BN132MA6	196-197
75	14.2	527	970	2.6	1.4	8.8	13900	C612_8.8	V10 P132	V 10 C V 10 F	P132	BN132MA6	196-197
76	14.5	398	896	2.0	0.9	13.1	9900	C512_13.1	V55 P112	V 5.5 C V 5.5 F	P112	BN112M4	194-195
88	16.7	449	827	3.0	1.6	7.5	13300	C612_7.5	V10 P132	V 10 C V 10 F	P132	BN132MA6	196-197
99	18.7	401	738	3.4	1.8	6.7	12900	C612_6.7	V10 P132	V 10 C V 10 F	P132	BN132MA6	196-197
102	19.4	298	670	2.7	1.2	9.8	9200	C512_9.8	V55 P112	V 5.5 C V 5.5 F	P112	BN112M4	194-195
114	21.6	268	602	3.0	1.3	8.8	8960	C512_8.8	V55 P112	V 5.5 C V 5.5 F	P112	BN112M4	194-195
128	24.4	237	534	3.1	1.5	7.8	8660	C512_7.8	V55 P112	V 5.5 C V 5.5 F	P112	BN112M4	194-195
143	27.1	213	479	3.4	1.7	7.0	8420	C512_7.0	V55 P112	V 5.5 C V 5.5 F	P112	BN112M4	194-195
179	34	170	383	2.6	1.1	5.6	7790	C512_5.6	V55 P112	V 5.5 C V 5.5 F	P112	BN112M4	194-195
179	34	221	408	2.8	1.6	3.7	10700	C612_3.7	V10 P132	V 10 C V 10 F	P132	BN132MA6	196-197
222	42	137	308	3.2	1.4	4.5	7310	C512_4.5	V55 P112	V 5.5 C V 5.5 F	P112	BN112M4	194-195
237	45	168	309	3.4	2.2	2.8	10000	C612_2.8	V10 P132	V 10 C V 10 F	P132	BN132MA6	196-197
270	51	112	253	5.6	2.6	3.7	9500	C612_3.7	V55 P112	V 5.5 C V 5.5 F	P112	BN112M4	196-197
303	58	100	226	4.2	1.9	3.3	6710	C512_3.3	V55 P112	V 5.5 C V 5.5 F	P112	BN112M4	194-195
357	68	85	192	6.6	3.5	2.8	9000	C612_2.8	V55 P112	V 5.5 C V 5.5 F	P112	BN112M4	196-197
385	73	79	178	5.1	2.2	2.6	6280	C512_2.6	V55 P112	V 5.5 C V 5.5 F	P112	BN112M4	194-195







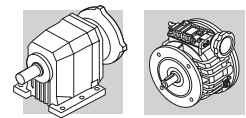

## 5.5 kW

$n_2$ min <sup>-1</sup>	$n_2'$ min <sup>-1</sup>	M <sub>2</sub> Nm	M <sub>2'</sub> Nm	S	S'	i	R <sub>n2</sub> N					IEC 	
5.7	1.1	6837	12590	1.1	0.6	116.7	60000	<b>C903_116.7</b>	— P132	— V 10 F	<b>P132</b>	<b>BN132MB6</b>	201
5.8	1.1	6882	13765	1.0	0.5	172.1	60000	<b>C903_172.1</b>	— P132	— V 10 F	<b>P132</b>	<b>BN132S4</b>	201
6.3	1.2	6310	12621	1.1	0.6	157.8	60000	<b>C903_157.8</b>	— P132	— V 10 F	<b>P132</b>	<b>BN132S4</b>	201
6.8	1.3	5851	11701	1.2	0.6	146.3	60000	<b>C903_146.3</b>	— P132	— V 10 F	<b>P132</b>	<b>BN132S4</b>	201
6.9	1.3	5636	10378	1.3	0.7	96.2	60000	<b>C903_96.2</b>	— P132	— V 10 F	<b>P132</b>	<b>BN132MB6</b>	201
7.5	1.4	5363	10725	1.3	0.7	134.1	60000	<b>C903_134.1</b>	— P132	— V 10 F	<b>P132</b>	<b>BN132S4</b>	201
8.6	1.6	4667	9334	1.5	0.8	116.7	60000	<b>C903_116.7</b>	— P132	— V 10 F	<b>P132</b>	<b>BN132S4</b>	201
9.3	1.8	4279	8558	1.7	0.8	107.0	60000	<b>C903_107.0</b>	— P132	— V 10 F	<b>P132</b>	<b>BN132S4</b>	201
9.4	1.8	4131	7606	1.0	0.5	70.5	35000	<b>C803_70.5</b>	— P132	— V 10 F	<b>P132</b>	<b>BN132MB6</b>	200
10.3	2.0	3895	7790	1.0	0.5	97.4	35000	<b>C803_97.4</b>	— P132	— V 10 F	<b>P132</b>	<b>BN132S4</b>	200
10.4	2.0	3847	7694	1.9	0.9	96.2	60000	<b>C903_96.2</b>	— P132	— V 10 F	<b>P132</b>	<b>BN132S4</b>	201
10.6	2.0	3662	6743	1.1	0.6	62.5	35000	<b>C803_62.5</b>	— P132	— V 10 F	<b>P132</b>	<b>BN132MB6</b>	200
11.2	2.1	3571	7142	1.1	0.6	89.3	35000	<b>C803_89.3</b>	— P132	— V 10 F	<b>P132</b>	<b>BN132S4</b>	200
11.2	2.1	3469	6386	2.0	1.1	59.2	60000	<b>C903_59.2</b>	— P132	— V 10 F	<b>P132</b>	<b>BN132MB6</b>	201
11.3	2.2	3527	7054	2.0	1.0	88.2	60000	<b>C903_88.2</b>	— P132	— V 10 F	<b>P132</b>	<b>BN132S4</b>	201
12.3	2.3	3247	6494	2.2	1.1	81.2	60000	<b>C903_81.2</b>	— P132	— V 10 F	<b>P132</b>	<b>BN132S4</b>	201
13.0	2.5	3075	6150	1.3	0.7	76.9	35000	<b>C803_76.9</b>	— P132	— V 10 F	<b>P132</b>	<b>BN132S4</b>	200
13.4	2.6	2975	5951	2.4	1.2	74.4	60000	<b>C903_74.4</b>	— P132	— V 10 F	<b>P132</b>	<b>BN132S4</b>	201
14.2	2.7	2819	5639	1.4	0.7	70.5	35000	<b>C803_70.5</b>	— P132	— V 10 F	<b>P132</b>	<b>BN132S4</b>	200
15.5	2.9	2583	5167	2.8	1.4	64.6	60000	<b>C903_64.6</b>	— P132	— V 10 F	<b>P132</b>	<b>BN132S4</b>	201
16.0	3.0	2499	4999	1.6	0.8	62.5	35000	<b>C803_62.5</b>	— P132	— V 10 F	<b>P132</b>	<b>BN132S4</b>	200
16.1	3.0	2420	4455	1.0	0.5	41.3	25000	<b>C703_41.3</b>	— P132	— V 10 F	<b>P132</b>	<b>BN132MB6</b>	198-199
16.9	3.2	2367	4735	3.0	1.5	59.2	60000	<b>C903_59.2</b>	— P132	— V 10 F	<b>P132</b>	<b>BN132S4</b>	201
17.0	3.2	2340	4309	1.4	0.7	39.1	35000	<b>C802_39.1</b>	— P132	— V 10 F	<b>P132</b>	<b>BN132MB6</b>	200
17.5	3.3	2291	4583	1.7	0.9	57.3	35000	<b>C803_57.3</b>	— P132	— V 10 F	<b>P132</b>	<b>BN132S4</b>	200
18.2	3.5	2195	4391	3.3	1.6	54.9	60000	<b>C903_54.9</b>	— P132	— V 10 F	<b>P132</b>	<b>BN132S4</b>	201
18.9	3.6	2101	3868	2.6	1.4	35.1	35000	<b>C902_35.1</b>	— P132	— V 10 F	<b>P132</b>	<b>BN132MB6</b>	201
19.1	3.6	2077	3824	1.0	0.5	34.7	25000	<b>C702_34.7</b>	— P132	— V 10 F	<b>P132</b>	<b>BN132MB6</b>	198-199
21.1	4.0	1896	3791	2.1	1.1	47.4	35000	<b>C803_47.4</b>	— P132	— V 10 F	<b>P132</b>	<b>BN132S4</b>	200
23.0	4.4	1740	3479	2.3	1.1	43.5	35000	<b>C803_43.5</b>	— P132	— V 10 F	<b>P132</b>	<b>BN132S4</b>	200
23.3	4.4	1720	3439	4.2	2.1	43.0	57000	<b>C903_43.0</b>	— P132	— V 10 F	<b>P132</b>	<b>BN132S4</b>	201
23.9	4.5	1658	3053	1.3	0.7	27.7	25000	<b>C702_27.7</b>	— P132	— V 10 F	<b>P132</b>	<b>BN132MB6</b>	198-199
24.2	4.6	1652	3303	1.4	0.7	41.3	25000	<b>C703_41.3</b>	— P132	— V 10 F	<b>P132</b>	<b>BN132S4</b>	198-199
25.4	4.8	1576	3151	4.5	2.3	39.4	55900	<b>C903_39.4</b>	— P132	— V 10 F	<b>P132</b>	<b>BN132S4</b>	201







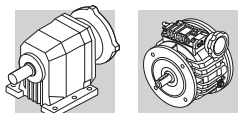

## 5.5 kW

$n_2$ min <sup>-1</sup>	$n_2'$ min <sup>-1</sup>	M <sub>2</sub> Nm	M <sub>2</sub> ' Nm	S	S'	i	R <sub>n2</sub> N					IEC 	
25.6	4.9	1597	3194	2.0	1.0	39.1	35000	C802_39.1	— P132	— V 10 F	P132	BN132S4	200
27.6	5.2	1436	2645	2.5	1.3	24.0	35000	C802_24.0	— P132	— V 10 F	P132	BN132MB6	200
28.8	5.5	1417	2835	1.5	0.7	34.7	25000	C702_34.7	— P132	— V 10 F	P132	BN132S4	198-199
29.0	5.5	1371	2524	1.5	0.8	22.9	25000	C702_22.9	— P132	— V 10 F	P132	BN132MB6	198-199
32	6.1	1279	2557	2.9	1.4	31.3	35000	C802_31.3	— P132	— V 10 F	P132	BN132S4	200
34	6.5	1155	2127	1.8	1.0	19.3	25000	C702_19.3	— P132	— V 10 F	P132	BN132MB6	198-199
34	6.5	1176	2351	1.4	0.7	29.4	15800	C613_29.4	V10 P132	V 10 C V 10 F	P132	BN132S4	196-197
36	6.9	1132	2263	1.9	0.9	27.7	25000	C702_27..7	— P132	— V 10 F	P132	BN132S4	198-199
37	6.9	1083	1995	3.4	1.9	18.1	35000	C802_18.1	— P132	— V 10 F	P132	BN132MB6	200
39	7.3	1058	2116	3.5	1.7	25.9	35000	C802_25.9	— P132	— V 10 F	P132	BN132S4	200
40	7.5	999	1840	2.1	1.1	16.7	25000	C702_16.7	— P132	— V 10 F	P132	BN132MB6	198-199
40	7.7	1013	2026	1.3	0.7	24.8	15300	C612_24.8	V10 P132	V 10 C V 10 F	P132	BN132S4	196-197
42	7.9	980	1961	3.6	1.8	24.0	35000	C802_24.0	— P132	— V 10 F	P132	BN132S4	200
44	8.3	935	1871	2.2	1.1	22.9	25000	C702_22.9	— P132	— V 10 F	P132	BN132S4	198-199
45	8.6	907	1814	4.1	2.0	22.2	35000	C802_22.2	— P132	— V 10 F	P132	BN132S4	200
46	8.7	856	1576	1.6	0.9	14.3	14900	C612_14.3	V10 P132	V 10 C V 10 F	P132	BN132MB6	196-197
47	8.9	844	1554	2.5	1.4	14.1	25000	C702_14.1	— P132	— V 10 F	P132	BN132MB6	198-199
52	9.8	788	1577	2.7	1.3	19.3	25000	C702_19.3	— P132	— V 10 F	P132	BN132S4	198-199
56	10.7	723	1446	1.9	0.9	17.7	14200	C612_17.7	V10 P132	V 10 C V 10 F	P132	BN132S4	196-197
63	11.9	650	1299	2.1	1.0	15.9	13900	C612_15.9	V10 P132	V 10 C V 10 F	P132	BN132S4	196-197
65	12.4	625	1250	3.4	1.7	15.3	23750	C702_15.3	— P132	— V 10 F	P132	BN132S4	198-199
71	13.5	576	1152	3.7	1.9	14.1	23550	C702_14.1	— P132	— V 10 F	P132	BN132S4	198-199
77	14.6	531	1062	4.0	2.0	13.0	22560	C702_13.0	— P132	— V 10 F	P132	BN132S4	198-199
83	15.7	494	989	2.7	1.4	12.1	13000	C612_12.1	V10 P132	V 10 C V 10 F	P132	BN132S4	196-197
89	17.0	458	915	4.7	2.3	11.2	22100	C702_11.2	— P132	— V 10 F	P132	BN132S4	198-199
102	19.4	400	801	3.4	1.7	9.8	12400	C612_9.8	V10 P132	V 10 C V 10 F	P132	BN132S4	196-197
114	21.6	359	719	3.8	1.9	8.8	12000	C612_8.8	V10 P132	V 10 C V 10 F	P132	BN132S4	196-197
133	25.3	306	613	4.4	2.2	7.5	11500	C612_7.5	V10 P132	V 10 C V 10 F	P132	BN132S4	196-197
144	27.2	275	507	2.4	1.3	4.6	11100	C612_4.6	V10 P132	V 10 C V 10 F	P132	BN132MB6	196-197
149	28.4	274	547	4.9	2.5	6.7	11100	C612_6.7	V10 P132	V 10 C V 10 F	P132	BN132S4	196-197
167	32	245	490	2.7	1.4	6.0	10600	C612_6.0	V10 P132	V 10 C V 10 F	P132	BN132S4	196-197
217	41	188	376	3.5	1.8	4.6	9800	C612_4.6	V10 P132	V 10 C V 10 F	P132	BN132S4	196-197
270	51	151	302	4.1	2.2	3.7	9300	C612_3.7	V10 P132	V 10 C V 10 F	P132	BN132S4	196-197
357	68	114	229	4.9	2.9	2.8	8800	C612_2.8	V10 P132	V 10 C V 10 F	P132	BN132S4	196-197



## 7.5 kW

$n_2$ min <sup>-1</sup>	$n_2'$ min <sup>-1</sup>	$M_2$ Nm	$M_2'$ Nm	S	S'	i	R <sub>n2</sub> N					IEC 	
6.6	1.3	8113	16225	1.5	0.7	150.4	85000	C1003_150.4	— P132	— V 10 F	P132	BN132MA4	202
7.2	1.4	7535	15071	1.5	0.7	139.7	85000	C1003_139.7	— P132	— V 10 F	P132	BN132MA4	202
8.3	1.6	6500	13000	1.8	0.9	120.5	85000	C1003_120.5	— P132	— V 10 F	P132	BN132MA4	202
8.9	1.7	6036	12072	2.0	1.0	111.9	85000	C1003_111.9	— P132	— V 10 F	P132	BN132MA4	202
9.3	1.8	5772	11543	1.2	0.6	107.0	60000	C903_107.0	— P132	— V 10 F	P132	BN132MA4	201
10.0	1.9	5383	10766	2.2	1.1	99.8	85000	C1003_99.8	— P132	— V 10 F	P132	BN132MA4	202
10.4	2.0	5189	10378	1.4	0.7	96.2	60000	C903_96.2	— P132	— V 10 F	P132	BN132MA4	201
10.8	2.0	5000	10000	2.4	1.2	92.7	85000	C1003_92.7	— P132	— V 10 F	P132	BN132MA4	202
11.3	2.2	4758	9515	1.5	0.7	88.2	60000	C903_88.2	— P132	— V 10 F	P132	BN132MA4	201
12.3	2.3	4380	8760	1.6	0.8	81.2	60000	C903_81.2	— P132	— V 10 F	P132	BN132MA4	201
13.0	2.5	4148	8296	1.0	0.5	76.9	35000	C803_76.9	— P132	— V 10 F	P132	BN132MA4	200
13.4	2.6	4013	8026	1.8	0.9	74.4	60000	C903_74.4	— P132	— V 10 F	P132	BN132MA4	201
14.2	2.7	3803	7606	1.1	0.5	70.5	35000	C803_70.5	— P132	— V 10 F	P132	BN132MA4	200
14.4	2.7	3743	7487	3.2	1.6	69.4	85000	C1003_69.4	— P132	— V 10 F	P132	BN132MA4	202
15.5	2.9	3485	6969	2.1	1.0	64.6	59510	C903_64.6	— P132	— V 10 F	P132	BN132MA4	201
15.5	2.9	3479	6958	3.4	1.7	64.5	85000	C1003_64.5	— P132	— V 10 F	P132	BN132MA4	202
16.0	3.0	3371	6743	1.2	0.6	62.5	35000	C803_62.5	— P132	— V 10 F	P132	BN132MA4	200
16.9	3.2	3193	6386	2.2	1.1	59.2	58610	C903_59.2	— P132	— V 10 F	P132	BN132MA4	201
17.4	3.3	3096	6192	3.9	1.9	57.4	85000	C1003_57.4	— P132	— V 10 F	P132	BN132MA4	202
17.5	3.3	3091	6182	1.3	0.6	57.3	35000	C803_57.3	— P132	— V 10 F	P132	BN132MA4	201
18.2	3.5	2961	5923	2.4	1.2	54.9	57800	C903_54.9	— P132	— V 10 F	P132	BN132MA4	201
18.8	3.6	2875	5750	4.2	2.1	53.3	85000	C1003_53.3	— P132	— V 10 F	P132	BN132MA4	202
19.9	3.8	2713	5426	2.6	1.3	50.3	56840	C903_50.3	— P132	— V 10 F	P132	BN132MA4	201
21.1	4.0	2557	5114	1.6	0.8	47.4	35000	C803_47.4	— P132	— V 10 F	P132	BN132MA4	200
23.0	4.4	2346	4693	1.7	0.9	43.5	35000	C803_43.5	— P132	— V 10 F	P132	BN132MA4	200
24.2	4.6	2228	4455	1.0	0.5	41.3	25000	C703_41.3	— P132	— V 10 F	P132	BN132MA4	198-199
25.6	4.9	2154	4309	1.5	0.7	39.1	35000	C802_39.1	— P132	— V 10 F	P132	BN132MA4	200
28.5	5.4	1934	3868	2.8	1.4	35.1	52610	C902_35.1	— P132	— V 10 F	P132	BN132MA4	201
28.8	5.5	1912	3824	1.1	0.5	34.7	25000	C702_34.7	— P132	— V 10 F	P132	BN132MA4	198-199
32	6.1	1725	3449	2.1	1.1	31.3	35000	C802_31.3	— P132	— V 10 F	P132	BN132MA4	200
34	6.5	1620	3240	3.6	1.8	29.4	50570	C902_29.4	— P132	— V 10 F	P132	BN132MA4	201
36	6.9	1526	3053	1.4	0.7	27.7	25000	C702_27.7	— P132	— V 10 F	P132	BN132MA4	198-199
37	7.0	1499	2997	3.7	1.8	27.2	49680	C902_27.2	— P132	— V 10 F	P132	BN132MA4	201
39	7.3	1427	2854	2.6	1.3	25.9	35000	C802_25.9	— P132	— V 10 F	P132	BN132MA4	200

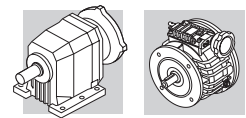

## 7.5 kW



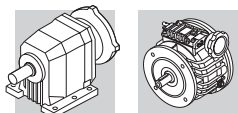

$n_2$ min <sup>-1</sup>	$n_2'$ min <sup>-1</sup>	$M_2$ Nm	$M_2'$ Nm	$S$	$S'$	$i$	$R_{n2}$ N					IEC	
42	7.9	1322	2645	2.7	1.3	24.0	35000	<b>C802_24.0</b>	—	—	<b>P132</b>	<b>BN132MA4</b>	200
44	8.3	1262	2524	1.7	0.8	22.9	25000	<b>C702_22.9</b>	—	—	<b>P132</b>	<b>BN132MA4</b>	198-199
45	8.6	1223	2446	3.0	1.5	22.2	35000	<b>C802_22.2</b>	—	—	<b>P132</b>	<b>BN132MA4</b>	200
49	9.3	1130	2259	3.1	1.6	20.5	35000	<b>C802_20.5</b>	—	—	<b>P132</b>	<b>BN132MA4</b>	200
52	9.8	1063	2127	2.0	1.0	19.3	25000	<b>C702_19.3</b>	—	—	<b>P132</b>	<b>BN132MA4</b>	198-199
55	10.5	997	1995	3.7	1.9	18.1	35000	<b>C802_18.1</b>	—	—	<b>P132</b>	<b>BN132MA4</b>	200
56	10.7	975	1951	1.4	0.7	17.7	14000	<b>C612_17.7</b>	V10 P132	V 10 C V 10 F	<b>P132</b>	<b>BN132MA4</b>	196-197
63	11.9	876	1752	1.5	0.8	15.9	13900	<b>C612_15.9</b>	V10 P132	V 10 C V 10 F	<b>P132</b>	<b>BN132MA4</b>	196-197
65	12.4	843	1686	2.5	1.2	15.3	23930	<b>C702_15.3</b>	—	—	<b>P132</b>	<b>BN132MA4</b>	198-199
67	12.8	821	1642	4.5	2.3	14.9	35000	<b>C802_14.9</b>	—	—	<b>P132</b>	<b>BN132MA4</b>	200
71	13.5	777	1554	2.8	1.4	14.1	23380	<b>C702_14.1</b>	—	—	<b>P132</b>	<b>BN132MA4</b>	198-199
77	14.6	716	1433	2.9	1.5	13.0	22720	<b>C702_13.0</b>	—	—	<b>P132</b>	<b>BN132MA4</b>	198-199
89	17.0	617	1234	3.5	1.7	11.2	21720	<b>C702_11.2</b>	—	—	<b>P132</b>	<b>BN132MA4</b>	198-199
92	17.4	601	12010	2.2	1.1	10.9	13100	<b>C612_10.9</b>	V10 P132	V 10 C V 10 F	<b>P132</b>	<b>BN132MA4</b>	196-197
98	18.6	562	1124	3.7	1.9	10.2	21030	<b>C702_10.2</b>	—	—	<b>P132</b>	<b>BN132MA4</b>	198-199
105	20.0	523	1047	4.1	2.1	9.5	21000	<b>C702_9.5</b>	—	—	<b>P132</b>	<b>BN132MA4</b>	198-199
114	21.6	485	970	2.8	1.4	8.8	12600	<b>C612_8.8</b>	V10 P132	V 10 C V 10 F	<b>P132</b>	<b>BN132MA4</b>	196-197
133	25.3	413	827	3.3	1.6	7.5	12200	<b>C612_7.5</b>	V10 P132	V 10 C V 10 F	<b>P132</b>	<b>BN132MA4</b>	196-197
149	28.4	369	738	3.7	1.8	6.7	11900	<b>C612_6.7</b>	V10 P132	V 10 C V 10 F	<b>P132</b>	<b>BN132MA4</b>	196-197
167	32	331	661	2.0	1.0	6.0	10300	<b>C612_6.0</b>	V10 P132	V 10 C V 10 F	<b>P132</b>	<b>BN132MA4</b>	196-197
217	41	253	507	2.6	1.3	4.6	9600	<b>C612_4.6</b>	V10 P132	V 10 C V 10 F	<b>P132</b>	<b>BN132MA4</b>	196-197
270	51	204	408	3.1	1.6	3.7	9100	<b>C612_3.7</b>	V10 P132	V 10 C V 10 F	<b>P132</b>	<b>BN132MA4</b>	196-197
357	68	154	309	3.7	2.2	2.8	8400	<b>C612_2.8</b>	V10 P132	V 10 C V 10 F	<b>P132</b>	<b>BN132MA4</b>	196-197

## 9.2 kW

6.6	1.3	10071	20142	1.2	0.6	150.4	85000	<b>C1003_150.4</b>	—	—	<b>P132</b>	<b>BN132MB4</b>	202
7.2	1.4	9354	18709	1.2	0.6	139.7	85000	<b>C1003_139.7</b>	—	—	<b>P132</b>	<b>BN132MB4</b>	202
8.3	1.6	8069	16137	1.5	0.7	120.5	85000	<b>C1003_120.5</b>	—	—	<b>P132</b>	<b>BN132MB4</b>	202
8.9	1.7	7493	14986	1.6	0.8	111.9	85000	<b>C1003_111.9</b>	—	—	<b>P132</b>	<b>BN132MB4</b>	202
10.0	1.9	6683	13365	1.8	0.9	99.8	85000	<b>C1003_99.8</b>	—	—	<b>P132</b>	<b>BN132MB4</b>	202
10.8	2.0	6207	12414	1.9	1.0	92.7	85000	<b>C1003_92.7</b>	—	—	<b>P132</b>	<b>BN132MB4</b>	202
11.7	2.2	5732	11464	2.1	1.0	85.6	85000	<b>C1003_85.6</b>	—	—	<b>P132</b>	<b>BN132MB4</b>	202



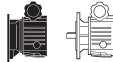



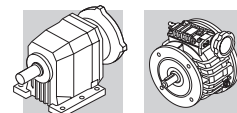

## 9.2 kW

$n_2$ min <sup>-1</sup>	$n_2'$ min <sup>-1</sup>	$M_2$ Nm	$M_2'$ Nm	S	S'	i	R <sub>n2</sub> N						
12.6	2.4	5317	10633	2.3	1.1	79.4	85000	C1003_79.4	—	—	P132	BN132MB4	202
14.4	2.7	4647	9294	2.6	1.3	69.4	85000	C1003_69.4	—	—	P132	BN132MB4	202
15.5	2.9	4326	8651	1.7	0.8	64.6	56870	C903_64.6	—	—	P132	BN132MB4	201
16.0	3.0	4185	8370	1.0	0.5	62.5	35000	C803_62.5	—	—	P132	BN132MB4	200
17.5	3.3	3837	7674	1.0	0.5	57.3	35000	C803_57.3	—	—	P132	BN132MB4	200
18.2	3.5	3676	7352	2.0	1.0	54.9	55550	C903_54.9	—	—	P132	BN132MB4	201
19.9	3.8	3368	6736	2.1	1.1	50.3	54780	C903_50.3	—	—	P132	BN132MB4	201
21.1	4.0	3174	6348	1.3	0.6	47.4	35000	C803_47.4	—	—	P132	BN132MB4	200
23.0	4.4	2913	5826	1.4	0.7	43.5	35000	C803_43.5	—	—	P132	BN132MB4	200
23.3	4.4	2879	5759	2.5	1.3	43.0	53310	C903_43.0	—	—	P132	BN132MB4	201
25.4	4.8	2638	5276	2.7	1.3	39.4	52460	C903_39.4	—	—	P132	BN132MB4	201
25.6	4.9	2674	5349	1.2	0.6	39.1	35000	C802_39.1	—	—	P132	BN132MB4	200
28.5	5.4	2401	4802	2.2	1.1	35.1	51140	C902_35.1	—	—	P132	BN132MB4	201
32	6.1	2141	4282	1.7	0.9	31.3	35000	C802_31.3	—	—	P132	BN132MB4	200
34	6.5	2011	4022	2.9	1.5	29.4	49340	C902_29.4	—	—	P132	BN132MB4	201
36	6.9	1895	3789	1.1	0.6	27.7	24630	C702_27.7	—	—	P132	BN132MB4	198-199
37	7.0	1860	3721	3.0	1.5	27.2	48560	C902_27.2	—	—	P132	BN132MB4	201
39	7.3	1772	3543	2.1	1.0	25.9	35000	C802_25.9	—	—	P132	BN132MB4	200
42	7.9	1642	3283	2.2	1.1	24.0	35000	C802_24.0	—	—	P132	BN132MB4	200
44	8.3	1566	3133	1.3	0.7	22.9	24680	C702_22.9	—	—	P132	BN132MB4	198-199
44	8.3	1566	3133	4.0	2.0	22.9	46760	C902_22.9	—	—	P132	BN132MB4	201
49	9.3	1402	2804	2.5	1.3	20.5	35000	C802_20.5	—	—	P132	BN132MB4	200
52	9.8	1320	2640	1.6	0.8	19.3	24500	C702_19.3	—	—	P132	BN132MB4	198-199
60	11.4	1142	2285	1.8	0.9	16.7	24100	C702_16.7	—	—	P132	BN132MB4	198-199
60	11.4	1142	2285	3.1	1.5	16.7	35000	C802_16.7	—	—	P132	BN132MB4	200
63	11.9	1088	2175	1.2	0.6	15.9	12500	C612_15.9	V10 P132	V 10 C V 10 F	P132	BN132MB4	196-197
65	12.4	1047	2093	2.0	1.0	15.3	24080	C702_15.3	—	—	P132	BN132MB4	198-199
67	12.8	1019	2038	3.6	1.8	14.9	33900	C802_14.9	—	—	P132	BN132MB4	200
70	13.3	978	1956	1.4	0.7	14.3	12200	C612_14.3	V10 P132	V 10 C V 10 F	P132	BN132MB4	196-197
71	13.5	964	1929	2.2	1.1	14.1	23530	C702_14.1	—	—	P132	BN132MB4	198-199
72	13.8	944	1888	3.7	1.9	13.8	33200	C802_13.8	—	—	P132	BN132MB4	200
77	14.6	889	1778	2.4	1.2	13.0	22860	C702_13.0	—	—	P132	BN132MB4	198-199
83	15.7	828	1655	1.6	0.8	12.1	11900	C612_12.1	V10 P132	V 10 C V 10 F	P132	BN132MB4	196-197
83	15.8	821	1642	4.5	2.3	12.0	31700	C802_12.0	—	—	P132	BN132MB4	200





## 9.2 kW

$n_2$ min <sup>-1</sup>	$n_2'$ min <sup>-1</sup>	$M_2$ Nm	$M_2'$ Nm	<b>S</b>	<b>S'</b>	<b>i</b>	$R_{n2}$ N						
<b>89</b>	<b>17.0</b>	766	1532	2.8	1.4	11.2	21860	<b>C702_11.2</b>	— P132	— V 10 F	<b>P132</b>	<b>BN132MB4</b>	198-199
<b>98</b>	<b>18.6</b>	698	1395	3.0	1.5	10.2	21140	<b>C702_10.2</b>	— P132	— V 10 F	<b>P132</b>	<b>BN132MB4</b>	198-199
<b>102</b>	<b>19.4</b>	670	1341	2.0	1.0	9.8	11500	<b>C612_9.8</b>	<b>V10</b> P132	<b>V 10 C</b> V 10 F	<b>P132</b>	<b>BN132MB4</b>	196-197
<b>105</b>	<b>20.0</b>	650	1300	3.3	1.7	9.5	24750	<b>C702_9.5</b>	— P132	— V 10 F	<b>P132</b>	<b>BN132MB4</b>	198-199
<b>114</b>	<b>21.6</b>	602	1204	2.2	1.1	8.8	11200	<b>C612_8.8</b>	<b>V10</b> P132	<b>V 10 C</b> V 10 F	<b>P132</b>	<b>BN132MB4</b>	196-197
<b>133</b>	<b>25.3</b>	513	1026	4.1	2.1	7.5	19520	<b>C702_7.5</b>	— P132	— V 10 F	<b>P132</b>	<b>BN132MB4</b>	198-199
<b>133</b>	<b>25.3</b>	513	1026	2.6	1.3	7.5	10800	<b>C612_7.5</b>	<b>V10</b> P132	<b>V 10 C</b> V 10 F	<b>P132</b>	<b>BN132MB4</b>	196-197
<b>149</b>	<b>28.4</b>	458	917	2.9	1.5	6.7	10500	<b>C612_6.7</b>	<b>V10</b> P132	<b>V 10 C</b> V 10 F	<b>P132</b>	<b>BN132MB4</b>	196-197
<b>167</b>	<b>32</b>	410	821	1.6	0.8	6.0	10000	<b>C612_6.0</b>	<b>V10</b> P132	<b>V 10 C</b> V 10 F	<b>P132</b>	<b>BN132MB4</b>	196-197
<b>217</b>	<b>41</b>	315	629	2.1	1.1	4.6	9370	<b>C612_4.6</b>	<b>V10</b> P132	<b>V 10 C</b> V 10 F	<b>P132</b>	<b>BN132MB4</b>	196-197
<b>270</b>	<b>51</b>	253	506	2.5	1.3	3.7	8890	<b>C612_3.7</b>	<b>V10</b> P132	<b>V 10 C</b> V 10 F	<b>P132</b>	<b>BN132MB4</b>	196-197
<b>357</b>	<b>68</b>	192	383	3.0	1.7	2.8	8270	<b>C612_2.8</b>	<b>V10</b> P132	<b>V 10 C</b> V 10 F	<b>P132</b>	<b>BN132MB4</b>	196-197

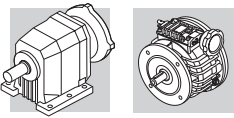

# C 11

## 22.9 - Dimensioni

## 22.9 - Dimensions

## 22.9 - Abmessungen

## 22.9 - Dimensions

### C 112\_P + V\_P(IEC)

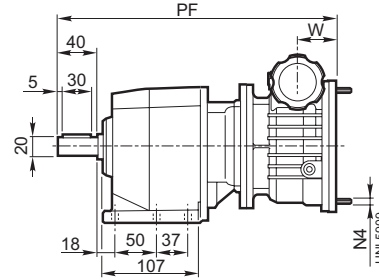
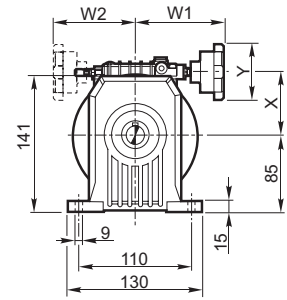
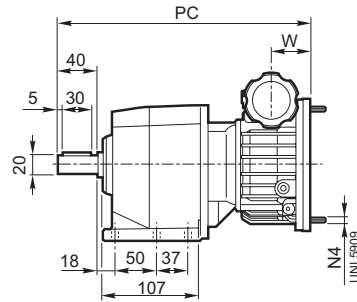
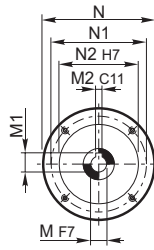

### C 112\_F + V\_P(IEC)

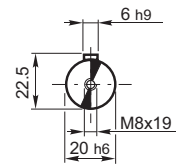
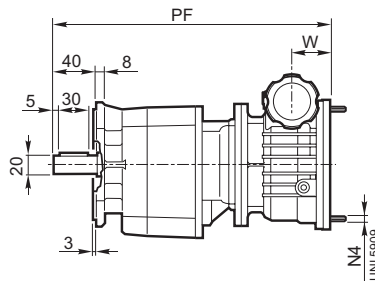
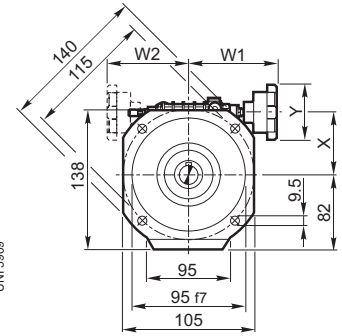
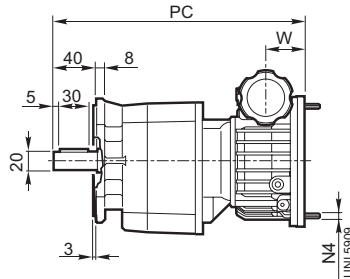
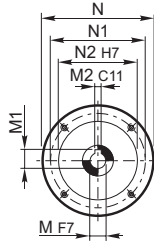

### C 112\_U + V\_P(IEC)

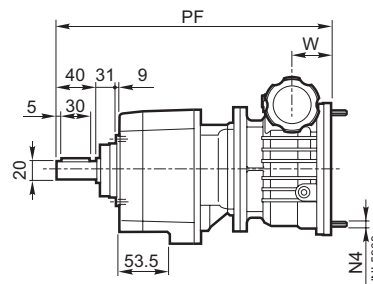
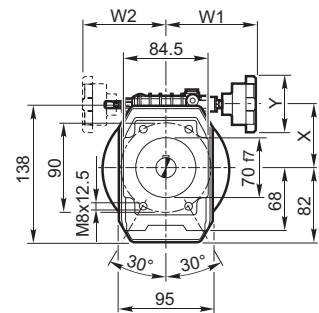
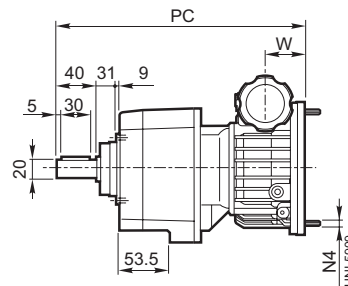
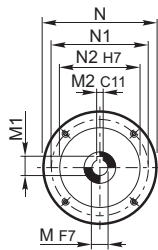

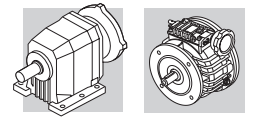

## C112\_UF + V\_P(IEC)

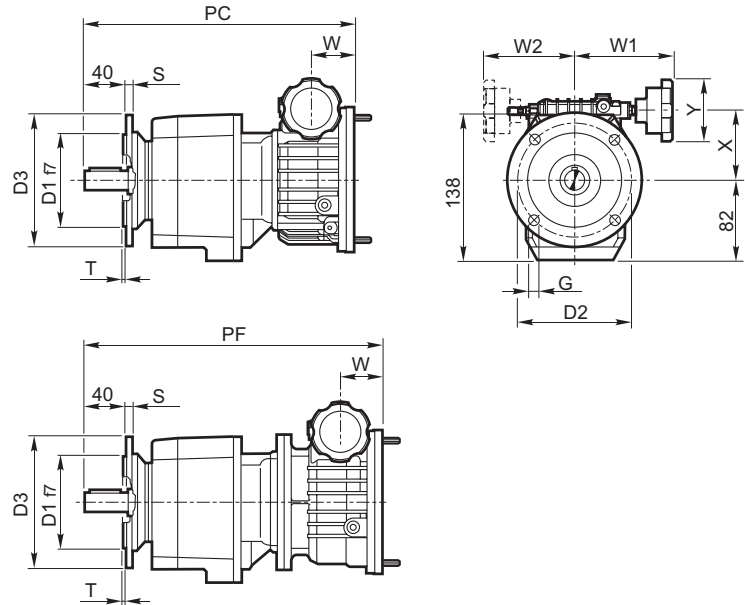

<b>UF</b>	<b>D<sub>1</sub></b>	<b>D<sub>2</sub></b>	<b>D<sub>3</sub></b>	<b>G</b>	<b>T</b>	<b>S</b>
<b>C 112_UFA</b>	80	100	120	7	3	8
<b>C 112_UFB</b>	95	115	140	9	3	10
<b>C 112_UFC</b>	110	130	160	9	3	10

	IEC	<b>V_C - V_F</b>												<b>C 11_ + V_C</b>			<b>C 11_ + V_F</b>					
		N	N1	N2	N4	M	M1	M2	W	W1	W2	X	Y	PC	<b>P</b>	<b>F</b>	<b>U</b>	PF	<b>P</b>	<b>F</b>	<b>U</b>	
<b>C 112_</b>	<b>V 0.25</b>	<b>P63</b>	140	115	95	M8x20	11	12.8	4	45	115	110	70	83	271	7.9	7.6	7.4	353	9.9	9.6	9.4
	<b>V 0.5</b>	<b>P71</b>	160	130	110	M8x20	14	16.3	5	47.5	115	110	78	83	274	11.1	10.7	10.6	355	13.1	12.7	12.6
	<b>V 0.5</b>	<b>P80</b>	200	165	130	M10x20	19	20.8*	6	51.5	115	110	78	83	278	11.1	10.7	10.6	359	13.1	12.7	12.6

\* Utilizzare linguetta ribassata di ns. fornitura 6x5x30 "A"

\* Use thin parallel key 6x5x30 "A" supplied by Bonfiglioli

\* Den bei uns verfügbaren flachen Federkeil "A" 6x5x30 verwenden

\* Utiliser une languette abaissée de notre fabrication 6x5x30 "A"

## C 112 + V\_P + BN

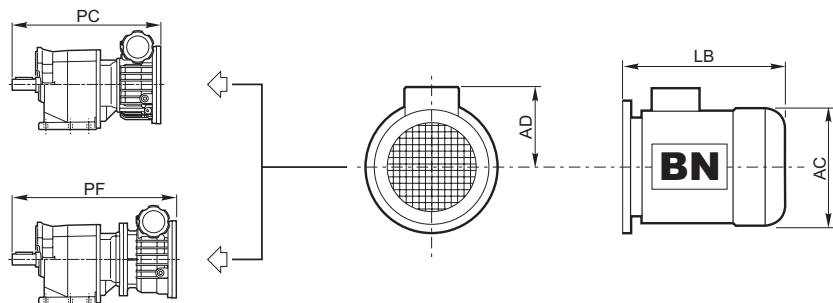

	IEC	<b>BN</b>			<b>C 11_ + V_C + BN</b>					<b>C 11_ + V_F + BN</b>			
		<b>AC</b>	<b>AD</b>	<b>LB</b>	<b>PC+LB</b>	<b>P</b>	<b>F</b>	<b>U</b>	<b>PF+LB</b>	<b>P</b>	<b>F</b>	<b>U</b>	
<b>C 112_</b>	<b>V 0.25</b>	<b>63</b>	121	95	184	455	11.8	11.5	11.3	537	13.8	13.5	13.3
	<b>V 0.25</b>	<b>71R</b>	138	108	219	490	13.3	13.0	12.8	572	15.3	15.0	14.8
	<b>V 0.5</b>	<b>71</b>	138	108	219	493	17.0	16.6	16.5	574	19.0	18.6	18.5
	<b>V 0.5</b>	<b>80</b>	156	119	234	512	21.0	20.6	20.5	593	13.0	22.6	22.5

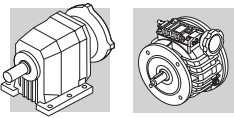

# C 21

## C 21\_P + V\_P(IEC)

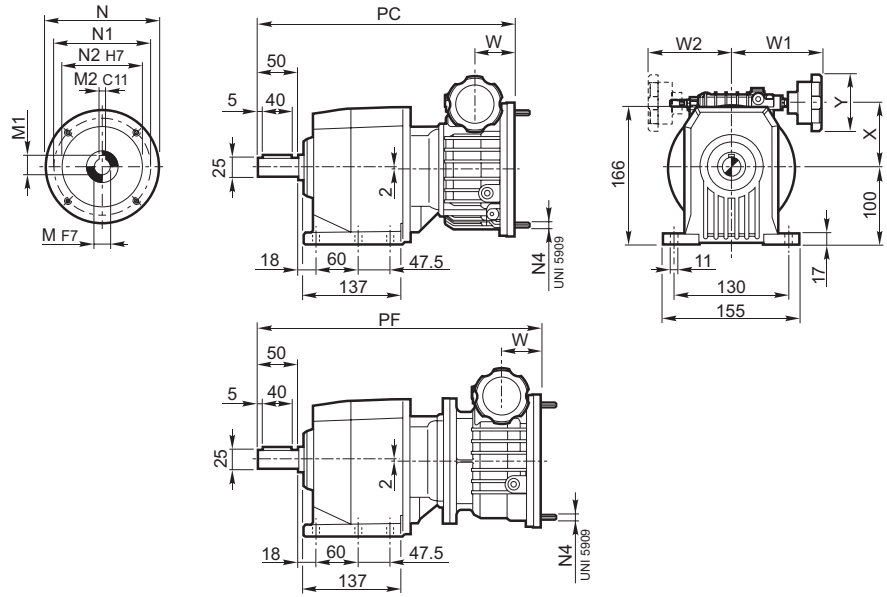

## C 21\_F + V\_P(IEC)

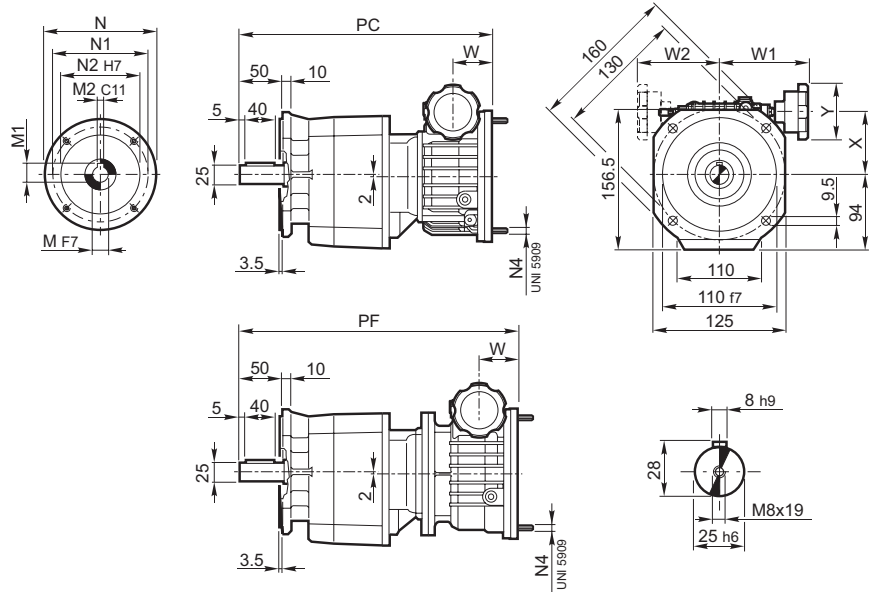

## C 21\_U + V\_P(IEC)

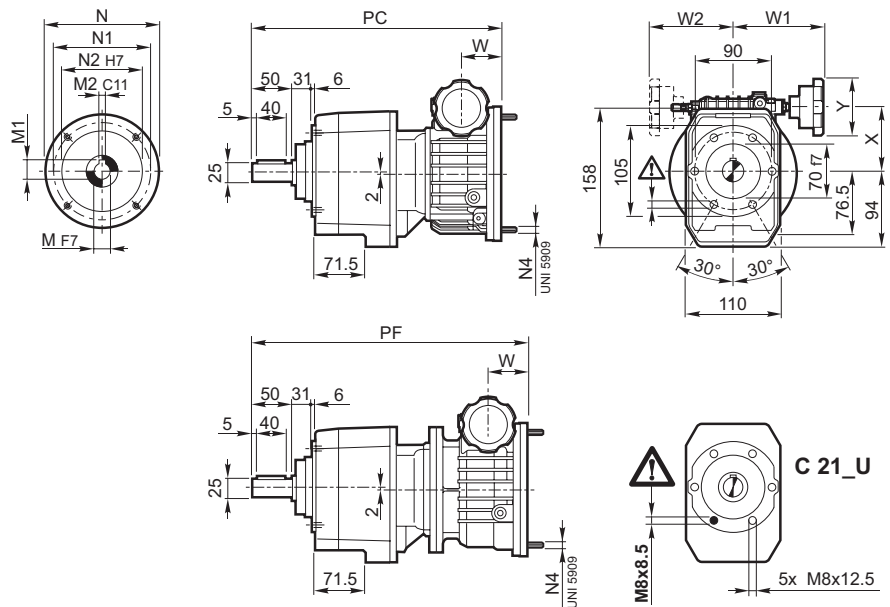

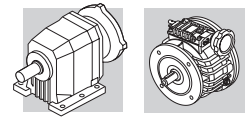

## C 21\_UF + V\_P(IEC)

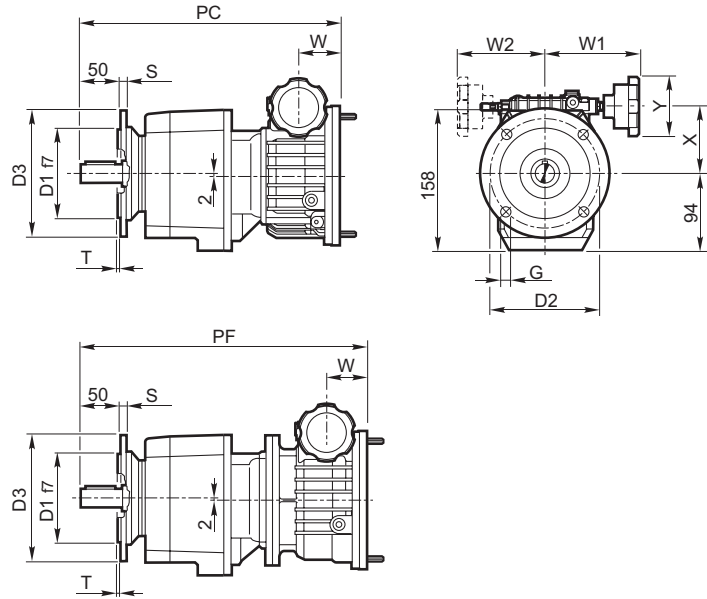

UF	D <sub>1</sub>	D <sub>2</sub>	D <sub>3</sub>	G	T	S
C 212_UFA	95	115	140	9	3	10
C 212_UFB	110	130	160	9	3	10
C 212_UFC	130	165	200	11	3.5	11

	IEC	V_C - V_F												C 21_ + V_C			C 21_ + V_F				
		N	N1	N2	N4	M	M1	M2	W	W1	W2	X	Y	PC	Kg			PF	Kg		
		P	F	U	P	F	U														
C 212_ V 0.25	P63	140	115	95	M8x20	11	12.8	4	45	115	110	68	83	307	9.2	8.9	9.0	382	11.7	11.4	11.2
	P71	160	130	110	M8x20	14	16.3	5	47.5	115	110	76	83	309	12.0	11.7	12.3	384	14.8	14.5	14.3
V 0.5	P80	200	165	130	M10x20	19	20.8*	6	51.5	115	110	76	83	313	12.0	11.7	12.3	388	14.8	14.5	14.3
V 1	P80	200	165	130	M10x20	19	21.8	6	59	133	124	95	83	—	—	—	—	429	22.3	22.0	21.8
V 1	P90	200	165	130	M10x20	24	26.3**	8	59	133	124	95	83	—	—	—	—	429	22.3	22.0	21.8

\* Utilizzare linguetta ribassata di ns. fornitura 6x5x30 "A"

\* Use thin parallel key 6x5x30 "A" supplied by Bonfiglioli

\* Den bei uns verfügbaren flachen Federkeil "A" 6x5x30 verwenden

\* Utiliser une languette abaissée de notre fabrication 6x5x30 "A"

\*\* Utilizzare linguetta ribassata di ns. fornitura 8x6x35 "A"

\*\* Use thin parallel key 8x6x35 "A" supplied by Bonfiglioli

\*\* Den bei uns verfügbaren flachen Federkeil "A" 8x6x35 verwenden

\*\* Utiliser une languette abaissée de notre fabrication 8x6x35 "A"

## C 21\_ + V\_P + BN

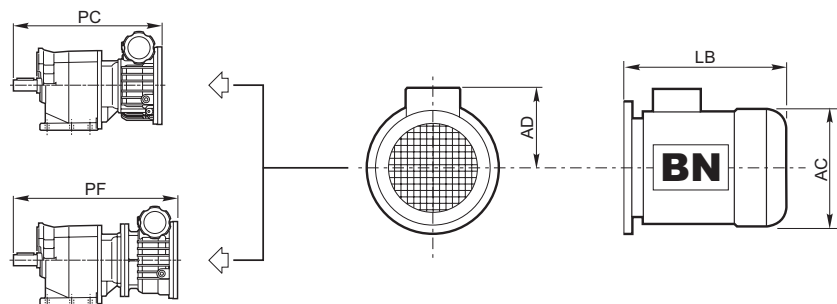

	IEC	BN			C 21_ + V_C					C 21_ + V_F			
		AC	AD	LB	PC+LB	Kg			PF+LB	Kg			
		P	F	U	P	F	U	P	F	U			
C 212_ V 0.25	63	121	95	184	491	13.1	12.8	12.9	566	15.6	15.3	15.1	
	71R	138	108	219	526	14.6	14.3	14.4	601	17.1	16.8	16.6	
V 0.5	71	138	108	219	528	17.9	17.6	18.2	603	20.7	20.4	20.2	
V 0.5	80	156	119	234	547	21.9	21.6	22.2	622	24.7	24.4	24.2	
V 1	80	156	119	234	—	—	—	—	663	32.2	31.9	31.7	
V 1	90S	176	133	276	—	—	—	—	705	34.6	34.3	34.1	
V 1	90L	176	133	276	—	—	—	—	705	36.6	36.3	36.1	

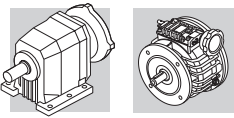

# C 31

## C 31\_P + V\_P(IEC)

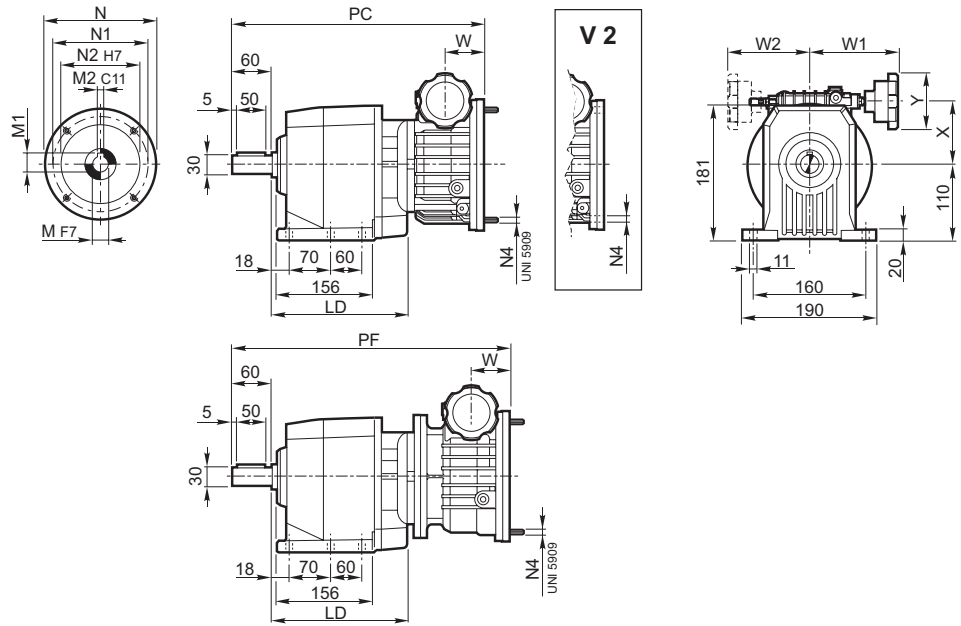

## C 31\_F + V\_P(IEC)

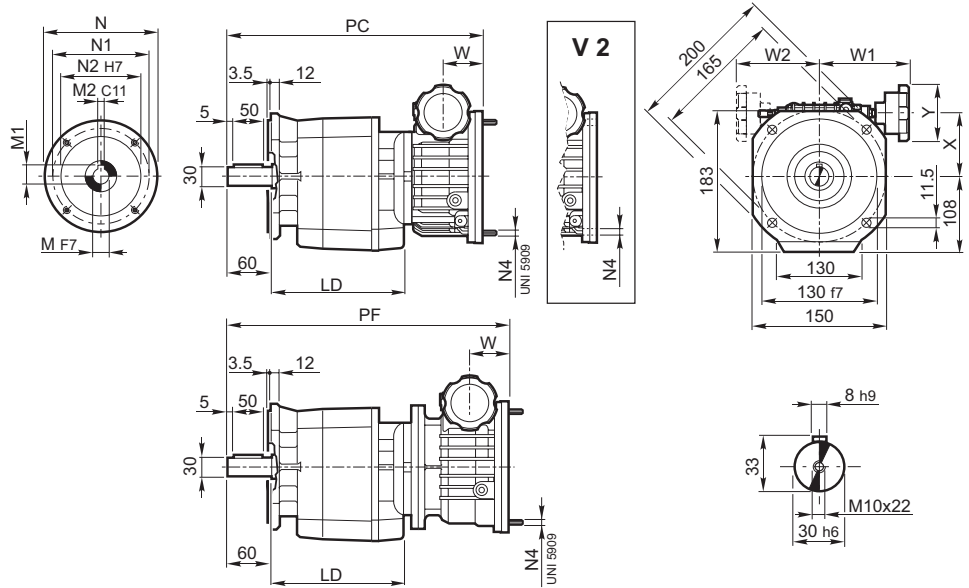

## C 31\_U + V\_P(IEC)

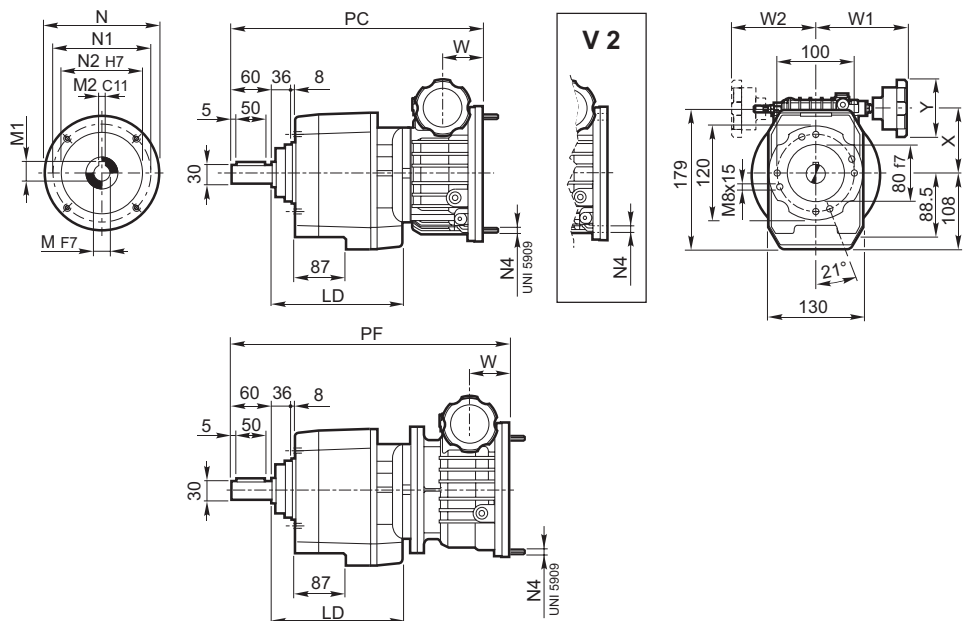

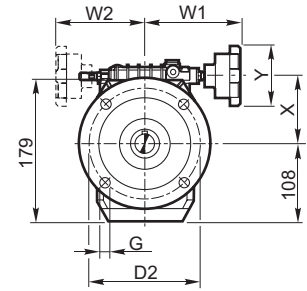
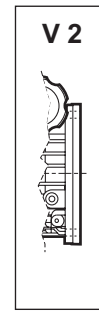
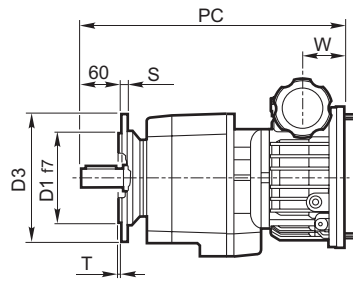
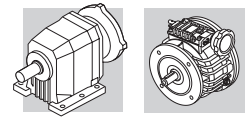

## C 31\_UF + V\_P(IEC)

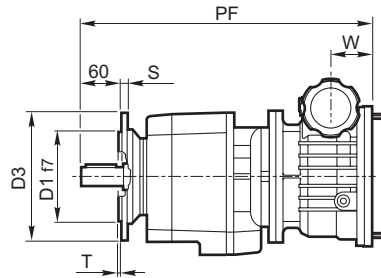

UF		D <sub>1</sub>	D <sub>2</sub>	D <sub>3</sub>	G	T	S
C 312_UFA	C 313_UFA	110	130	160	9	3	10
C 312_UFB	C 313_UFB	130	165	200	11	3.5	11
C 312_UFC	C 313_UFC	180	215	250	14	4	13

	IEC	V_C - V_F													C 31_ + V_C			C 31_ + V_F					
		LD	N	N1	N2	N4	M	M1	M2	W	W1	W2	X	Y	PC	Kg			PF	Kg			
		P	F	U	P	F	U																
C 312_	V 0.25	P63	217.5	140	115	95	M8x20	11	12.8	4	45	115	110	70	83	—	—	—	—	416	14.5	14.2	13.9
	V 0.5	P71	217.5	160	130	110	M8x20	14	16.3	5	47.5	115	110	78	83	344	14.7	14.9	14.6	418	17.7	17.4	17.1
	V 0.5	P80	227.5	200	165	130	M10x20	19	20.8*	6	51.5	115	110	78	83	348	14.7	14.9	14.6	422	17.7	17.4	17.1
	V 1	P80	227.5	200	165	130	M10x20	19	21.8	6	59	133	124	97	83	380	22.2	22.4	22.1	464	25.2	24.9	24.6
	V 1	P90	227.5	200	165	130	M10x20	24	26.3**	8	59	133	124	97	83	380	22.2	22.4	22.1	464	25.2	24.9	24.6
C 313_	V 0.25	P63	—	140	115	95	M8x20	11	12.8	4	45	115	110	70	83	392	13.2	12.9	12.9	473	15.7	15.4	15.1

\* Utilizzare linguetta ribassata di ns. fornitura 6x5x30 "A"

\* Use thin parallel key 6x5x30 "A" supplied by Bonfiglioli

\* Den bei uns verfügbaren flachen Federkeil "A" 6x5x30 verwenden

\* Utiliser une languette abaissée de notre fabrication 6x5x30 "A"

\*\* Utilizzare linguetta ribassata di ns. fornitura 8x6x35 "A"

\*\* Use thin parallel key 8x6x35 "A" supplied by Bonfiglioli

\*\* Den bei uns verfügbaren flachen Federkeil "A" 8x6x35 verwenden

\*\* Utiliser une languette abaissée de notre fabrication 8x6x35 "A"

## C 31\_ + V\_P + BN

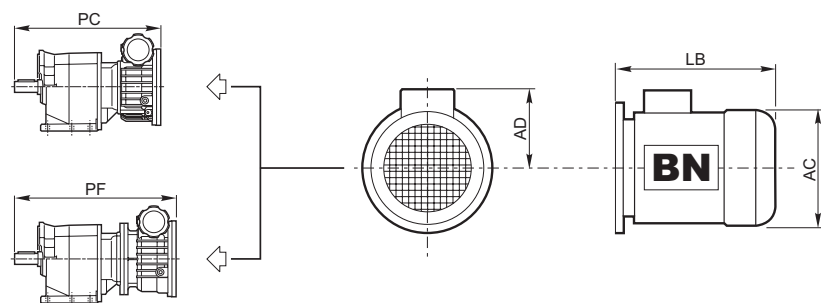

	IEC	BN				C 31_ + V_C				C 31_ + V_F			
		AC	AD	LB	PC+LB	Kg			PF+LB	Kg			
		P	F	U	P	F	U	P	F	U			
C 312_	V 0.25	63	121	95	184	—	—	—	—	600	18.4	18.1	17.8
	V 0.25	71R	138	108	219	—	—	—	—	635	19.9	19.6	19.3
	V 0.5	71	138	108	219	563	20.6	20.8	20.5	637	23.6	23.3	23.0
	V 0.5	80	156	119	234	582	24.6	24.8	24.5	656	27.6	27.3	27
	V 1	80	156	119	234	614	32	32	32	698	35	35	35
	V 1	90S	176	133	276	656	35	35	34	740	38	37	37
	V 1	90L	176	133	276	656	37	37	36	740	40	39	39
	V 2	90S	176	133	276	—	—	—	—	764	42	42	42
	V 2	90L	176	133	276	—	—	—	—	764	44	44	44
C 313_	V 0.25	63	121	95	184	576	17.1	16.8	16.8	657	19.6	19.3	19.0
	V 0.25	71R	138	108	219	611	18.6	18.3	18.3	692	21.1	20.8	20.5

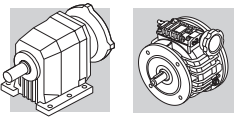

# C 35

## C 35\_P + V\_P(IEC)

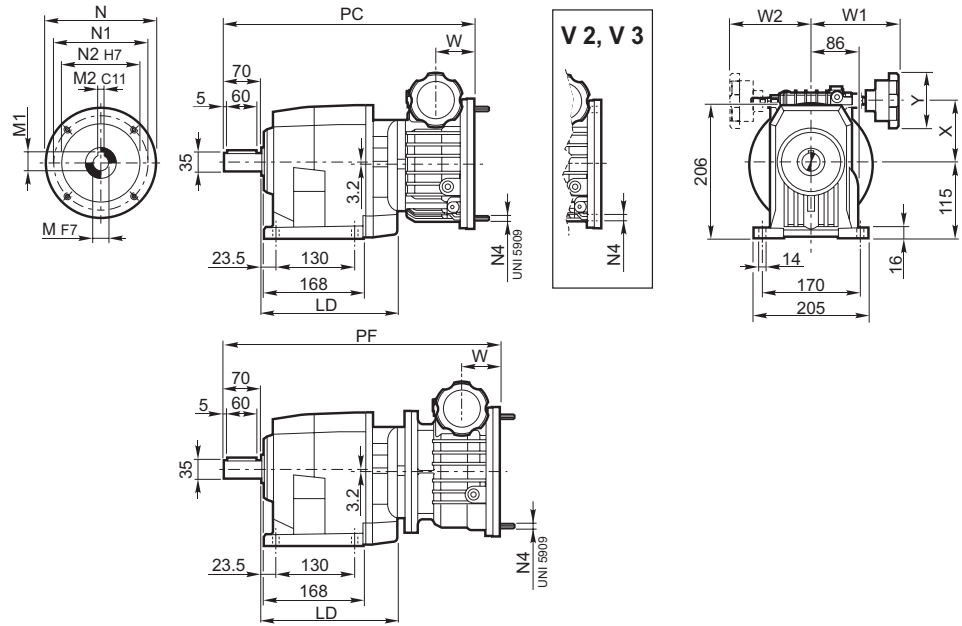

## C 35\_U + V\_P(IEC)

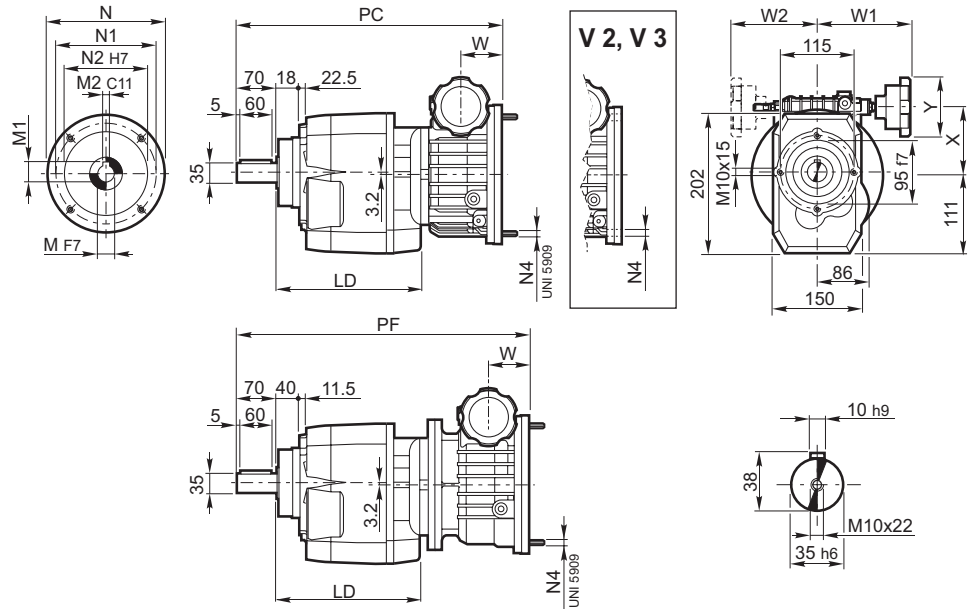

## C 35\_UF + V\_P(IEC)

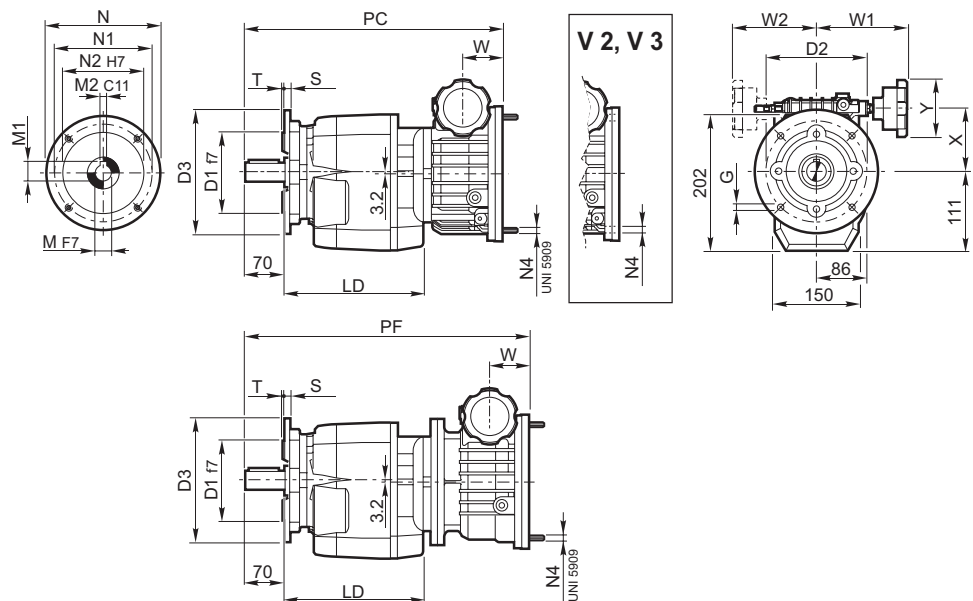



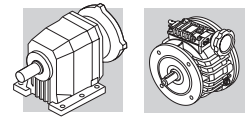

UF			D <sub>1</sub>	D <sub>2</sub>	D <sub>3</sub>	G	T	S
C 352_UFA	C 353_UFA	C 354_UFA	130	165	200	11	3.5	11
C 352_UFB	C 353_UFB	C 354_UFB	180	215	250	14	4	14

	IEC	V_C - V_F													C 35_ + V_C			C 35_ + V_F		
		LD	N	N1	N2	N4	M	M1	M2	W	W1	W2	X	Y	PC	P <sup>Kg</sup>	U	PF	P <sup>Kg</sup>	U
C 352_ 0.25	P63	226	140	115	95	M8x20	11	12.8	4	45	115	110	66.8	83	—	—	—	435	20.8	17.8
C 353_ V 0.5	P71	226	160	130	110	M8x20	14	16.3	5	47.5	115	110	74.8	83	360	22.0	21.2	437	24.0	21.0
	P80	236	200	165	130	M10x20	19	20.8*	6	51.5	115	110	74.8	83	364	22.0	21.2	441	24.0	21.0
	P80	236	200	165	130	M10x20	19	21.8	6	59	133	124	93.8	83	396	30	29.2	468	32	28.5
	P90	236	200	165	130	M10x20	24	26.3**	8	59	133	124	93.8	83	396	30	29.2	468	32	28.5
	P90	236	200	165	130	M10x15	24	27.3	8	74.1	137	120	109.8	83	—	—	—	492	36	33
	P100	236	250	215	180	M12x23	28	31.3	8	91	173	—	147.2	109	—	—	—	556	60	58
	P112	236	250	215	180	M12x23	28	31.3	8	91	173	—	147.2	109	—	—	—	556	60	58
C 354_ V 0.25	P63	—	140	115	95	M8x20	11	12.8	4	45	115	110	66.8	83	408	20.0	19.2	492	24.5	19.3
	P71	—	160	130	110	M8x20	14	16.3	5	47.5	115	110	74.8	83	410	26.0	25.2	494	27.5	22.5
	P80	—	200	165	130	M10x20	19	20.8*	6	51.5	115	110	74.8	83	414	26.0	25.2	498	27.5	22.5
	P80	—	200	165	130	M10x20	19	21.8	6	59	133	124	93.8	83	—	—	—	540	35	30

\* Utilizzare linguetta ribassata di ns. fornitura 6x5x30 "A"

\* Use thin parallel key 6x5x30 "A" supplied by Bonfiglioli

\* Den bei uns verfügbaren flachen Federkeil "A" 6x5x30 verwenden

\* Utiliser une languette abaissée de notre fabrication 6x5x30 "A"

\*\* Utilizzare linguetta ribassata di ns. fornitura 8x6x35 "A"

\*\* Use thin parallel key 8x6x35 "A" supplied by Bonfiglioli

\*\* Den bei uns verfügbaren flachen Federkeil "A" 8x6x35 verwenden

\*\* Utiliser une languette abaissée de notre fabrication 8x6x35 "A"

## C 35\_ + V\_P + BN

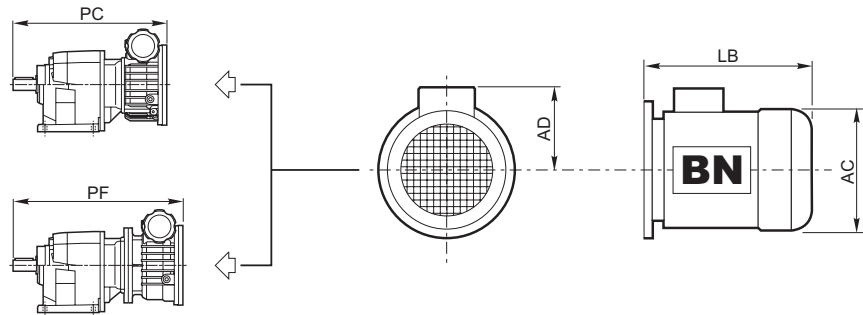

	IEC	BN			C 35_ + V_C			C 35_ + V_F		
		AC	AD	LB	PC+LB	P <sup>Kg</sup>	U	PF+LB	P <sup>Kg</sup>	U
C 352_ V 0.25	63	121	95	184	—	—	—	618.5	24.7	21.7
C 353_ V 0.25	71R	138	108	219	—	—	—	653.5	26.2	23.2
	71	138	108	219	578.5	27.9	27.1	656	29.9	26.9
	80	156	119	234	597.5	31.9	31.1	675	34	31
	80	156	119	234	629.5	39.9	39.1	701.5	41	38
	90S	176	133	276	671.5	42.3	41.5	743.5	43.8	40.8
	90L	176	133	276	671.5	44.3	43.5	743.5	45.8	42.8
	90S	176	133	276	—	—	—	767.5	48.1	45.6
	90L	176	133	276	—	—	—	767.5	50.1	47.6
	100R	195	142	307	—	—	—	798.5	58.1	55.6
	100	195	142	307	—	—	—	862.5	80.3	77.8
	112	219	157	325	—	—	—	880.5	90.3	87.8
C 354_ V 0.25	63	121	95	184	591.5	23.9	23.1	675.5	28.4	23.2
	71R	138	108	219	626.5	25.4	24.6	710.5	29.9	24.7
	71	138	108	219	629	31.9	31.1	713	33.4	28.4
	80	156	119	234	648	35.9	35.1	732	37.4	32.4
	80	156	119	234	—	—	—	773.5	45	39.9

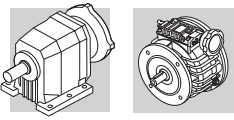

# C 41

## C 41\_P + V\_P(IEC)

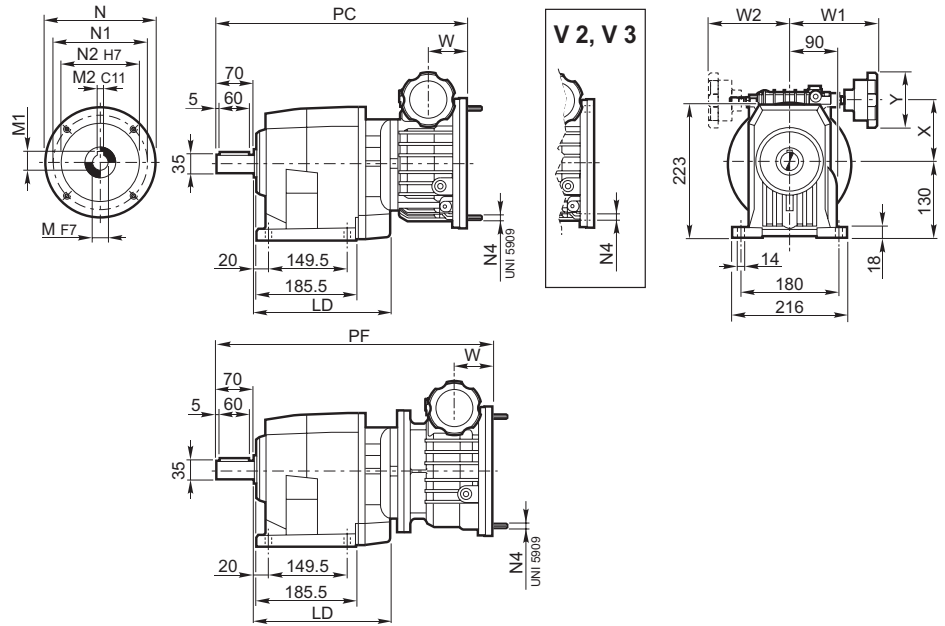

## C 41\_U + V\_P(IEC)

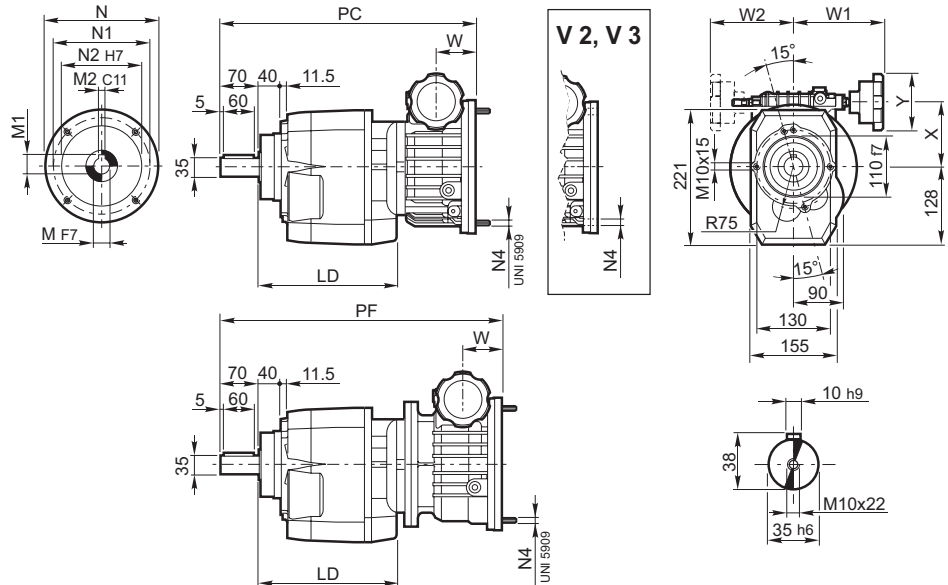

## C 41\_UF + V\_P(IEC)

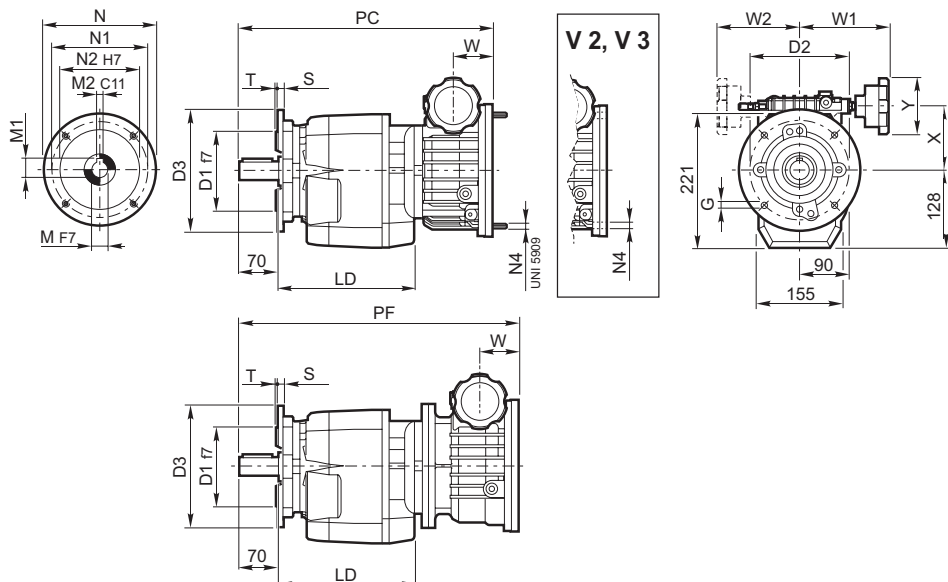

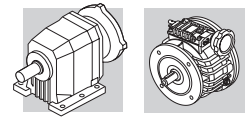

UF			D <sub>1</sub>	D <sub>2</sub>	D <sub>3</sub>	G	T	S
C 412_UFA	C 413_UFA	C 414_UFA	130	165	200	11	3.5	11
C 412_UFB	C 413_UFB	C 414_UFB	180	215	250	14	4	13

		IEC	V_C - V_F													C 41_ + V_C			C 41_ + V_F		
			LD	N	N1	N2	N4	M	M1	M2	W	W1	W2	X	Y	PC	Kg P U		PF	Kg P U	
C 412 C 413	V 0.5	P71	235.5	160	130	110	M8x20	14	16.3	5	47.5	115	110	78	83	381	29.5	25.9	448	35	29.9
	V 0.5	P80	251.5	200	165	130	M10x20	19	20.8*	6	51.5	115	110	78	83	385	29.5	25.9	452	35	29.9
	V 1	P80	251.5	200	165	130	M10x20	19	21.8	6	59	133	124	97	83	409	37	34	494	42	38
	V 1	P90	251.5	200	165	130	M10x20	24	26.3**	8	59	133	124	97	83	409	37	34	494	42	38
	V 2	P90	251.5	200	165	130	M10x15	24	27.3	8	74.1	137	120	113	83	432	41	36	518	47	42
	V 3	P100	—	250	215	180	M12x23	28	31.3	8	91	173	—	147.2	109	—	—	—	572	70	66
	V 3	P112	—	250	215	180	M12x23	28	31.3	8	91	173	—	147.2	109	—	—	—	572	70	66
C 414_	V 0.25	P63	—	140	115	95	M8x20	11	12.8	4	45	115	110	70	83	432	28.5	26.0	517	33	29.8
	V 0.5	P71	—	160	130	110	M8x20	14	16.3	5	47.5	115	110	78	83	435	32	29.2	519	36	33
	V 0.5	P80	—	200	165	130	M10x20	19	20.8*	6	51.5	115	110	78	83	439	32	29.2	523	36	33
	V 1	P80	—	200	165	130	M10x20	19	21.8	6	59	133	124	97	83	—	—	—	565	43	41
	V 1	P90	—	200	165	130	M10x20	24	26.3**	8	59	133	124	97	83	—	—	—	565	43	41

\* Utilizzare linguetta ribassata di ns. fornitura 6x5x30 "A"

\* Use thin parallel key 6x5x30 "A" supplied by Bonfiglioli

\* Den bei uns verfügbaren flachen Federkeil "A" 6x5x30 verwenden

\* Utiliser une languette abaissée de notre fabrication 6x5x30 "A"

\*\* Utilizzare linguetta ribassata di ns. fornitura 8x6x35 "A"

\*\* Use thin parallel key 8x6x35 "A" supplied by Bonfiglioli

\*\* Den bei uns verfügbaren flachen Federkeil "A" 8x6x35 verwenden

\*\* Utiliser une languette abaissée de notre fabrication 8x6x35 "A"

## C 41\_ + V\_P + BN

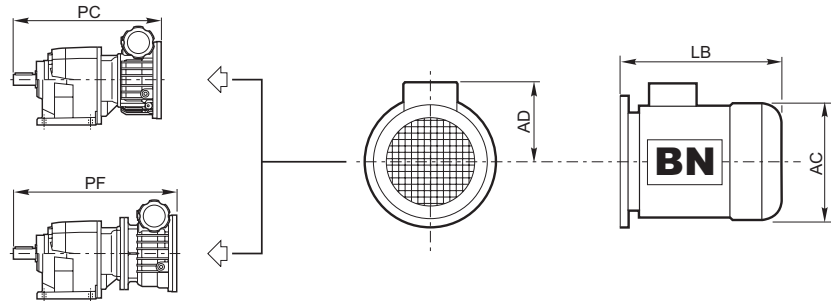

	IEC	BN			C 41_ + V_C			C 41_ + V_F			
		AC	AD	LB	PC+LB	Kg P U		PF+LB	Kg P U		
C 412_ V 0.5	71	138	108	219	599.5	35.4	32.4	667	40.4	35.8	
C 413_ V 0.5	80	156	119	234	618.5	39.4	36.4	686	44.4	39.8	
V 1	80	156	119	234	643	47	45	727.5	52	47.4	
V 1	90S	176	133	276	685	49.4	47.4	769.5	54.4	49.8	
V 1	90L	176	133	276	685	51.4	49.4	769.5	56.4	51.8	
V 2	90S	176	133	276	708	53.1	50.1	793.5	59.1	54.5	
V 2	90L	176	133	276	708	55.1	52.1	793.5	61.1	56.5	
V 2	100R	195	142	307	739	63.1	60.1	824.5	69.1	64.5	
V 3	100	195	142	307	—	—	—	878.5	90	86.4	
V 3	112	219	157	325	—	—	—	896.5	110	96.4	
C 414_	V 0.25	63	121	95	184	616	32.4	29.6	700.5	36.4	33.7
	V 0.25	71R	138	108	219	651	33.9	31.1	735.5	37.9	35.2
	V 0.5	71	138	108	219	653.5	37.4	34.6	738	41.4	38.9
	V 0.5	80	156	119	234	672.5	41.4	38.6	757	45.4	42.9
	V 1	80	156	119	234	—	—	—	798.5	53	50.5
	V 1	90S	176	133	276	—	—	—	840.5	55.4	52.9
	V 1	90L	176	133	276	—	—	—	840.5	57.4	54.9

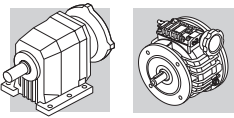

# C 51

**C 51\_P + V\_P(IEC)**

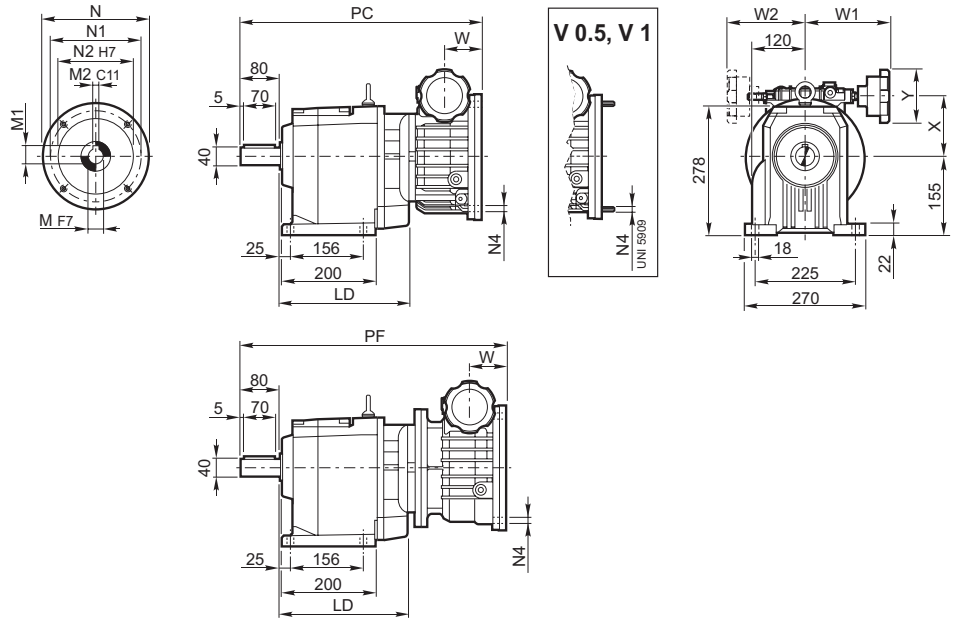

**C 51\_U + V\_P(IEC)**

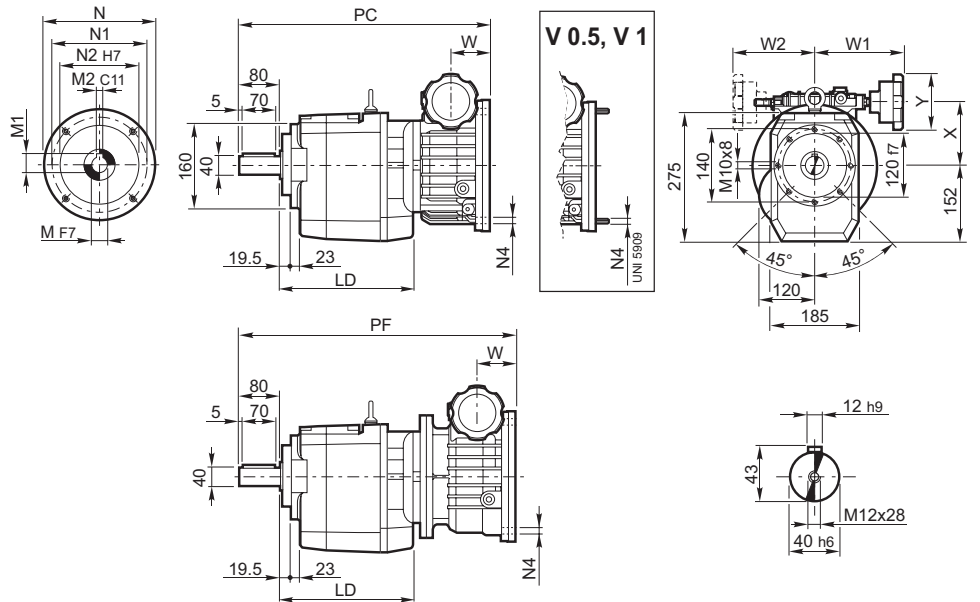

**C 51\_UF + V\_P(IEC)**

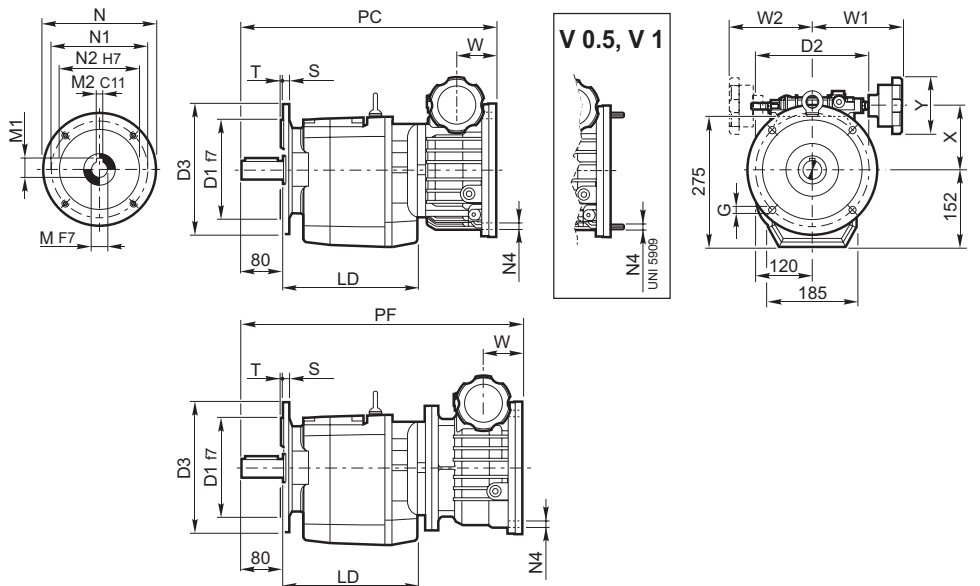

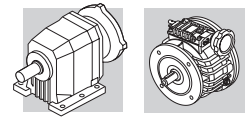

UF			D <sub>1</sub>	D <sub>2</sub>	D <sub>3</sub>	G	T	S
C 512_UFA	C 513_UFA	C 514_UFA	180	215	250	14	4	13
C 512_UFB	C 513_UFB	C 514_UFB	230	265	300	14	4	16

	IEC	V_C - V_F														C 51_ + V_C			C 51_ + V_F		
		LD	N	N1	N2	N4	M	M1	M2	W	W1	W2	X	Y	PC	P	U	PF	P	U	
C 512_ V 1	P80	267.5	200	165	130	M10x20	19	21.8	6	59	133	124	97	83	—	—	—	519	58	53	
C 513_ V 1	P90	267.5	200	165	130	M10x20	24	26.3**	8	59	133	124	97	83	—	—	—	519	58	53	
	V 2	P90	267.5	200	165	130	M10x15	24	27.3	8	74.1	137	120	113	83	458	58	53	543	63	58
	V 3	P100	252.5	250	215	180	M12x23	28	31.3	8	91	172.5	—	150.5	109	500	72	69	607	87	82
	V 3	P112	252.5	250	215	180	M12x23	28	31.3	8	91	172.5	—	150.5	109	500	72	69	607	87	82
	V 5.5	P112	252.5	250	215	180	M12x23	28	31.3	8	91	172.5	—	150.5	109	500	72	69	607	88	83
C 514_ V 0.5	P71	—	160	130	110	M8x20	14	16.3	5	47.5	115	110	78	83	470	45	42	544	55	51	
	V 0.5	P80	—	200	165	130	M10x20	19	20.8*	6	51.5	115	110	78	83	474	45	42	548	55	51
	V 1	P80	—	200	165	130	M10x20	19	21.8	6	59	133	124	97	83	506	60	52	590	63	59
	V 1	P90	—	200	165	130	M10x20	24	26.3**	8	59	133	124	97	83	506	60	52	590	63	59

\* Utilizzare linguetta ribassata di ns. fornitura 6x5x30 "A"

\* Use thin parallel key 6x5x30 "A" supplied by Bonfiglioli

\* Den bei uns verfügbaren flachen Federkeil "A" 6x5x30 verwenden

\* Utiliser une languette abaissée de notre fabrication 6x5x30 "A"

\*\* Utilizzare linguetta ribassata di ns. fornitura 8x6x35 "A"

\*\* Use thin parallel key 8x6x35 "A" supplied by Bonfiglioli

\*\* Den bei uns verfügbaren flachen Federkeil "A" 8x6x35 verwenden

\*\* Utiliser une languette abaissée de notre fabrication 8x6x35 "A"

## C 51\_ + V\_P + BN

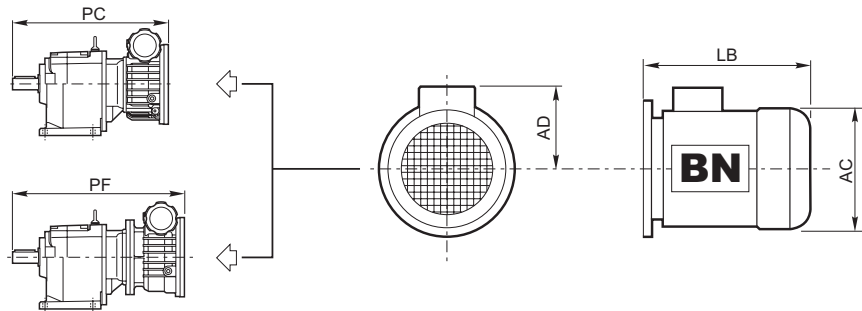

	IEC	BN			C 51_ + V_C			C 51_ + V_F			
		AC	AD	LB	PC+LB	P	U	PF+LB	P	U	
C 512_ V 1	80	156	119	234	—	—	—	753	68	63	
C 513_ V 1	90S	176	133	276	—	—	—	795	70.4	65.4	
	90L	176	133	276	—	—	—	795	72.4	67.4	
	V 2	90S	176	133	276	733.5	65.1	62.1	819	75.1	70.1
	V 2	90L	176	133	276	733.5	67.1	64.1	819	77.1	72.1
	V 2	100R	195	142	307	764.5	75.1	72.1	850	85.1	80.1
	V 3	100	195	142	307	807	92	89	914	107	102
	V 3	112	219	157	325	825	102	99	932	117	112
	V 5.5	112	219	157	325	825	102	99	932	118	113
C 514_ V 0.5	71	138	108	219	698	50.9	47.9	763	60.4	56.4	
	V 0.5	80	156	119	234	708	54.9	51.9	782	64.4	60.4
	V 1	80	156	119	234	740	65	61.9	824	73	69
	V 1	90S	176	133	276	782	67.4	64.3	866	75.4	71.4
	V 1	90L	176	133	276	782	69.4	66.3	866	77.4	73.4

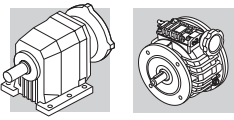

# C 61

## C 61\_P + V\_P(IEC)

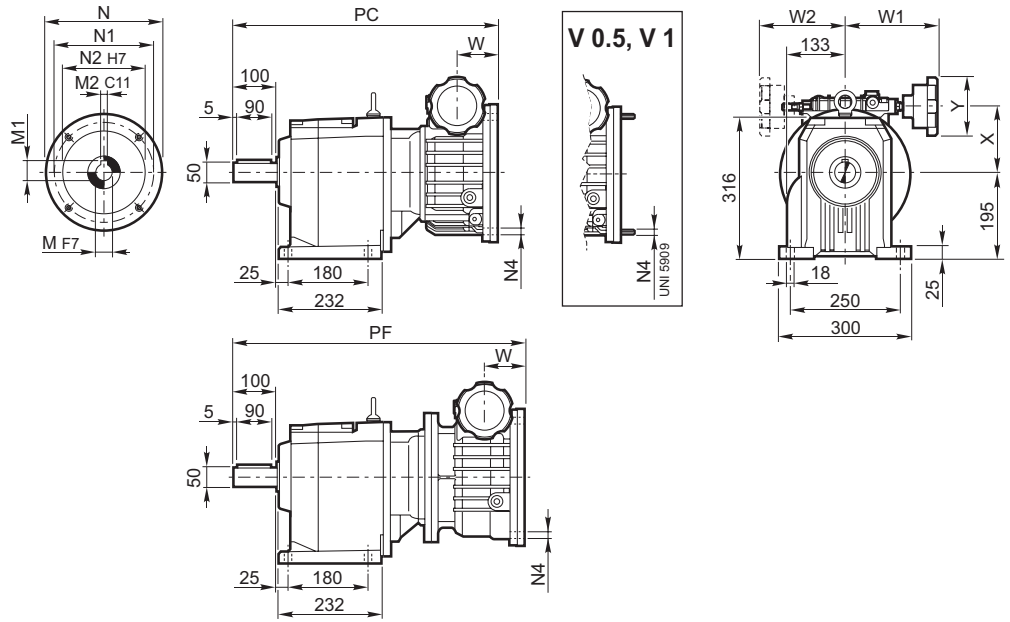

## C 61\_U + V\_P(IEC)

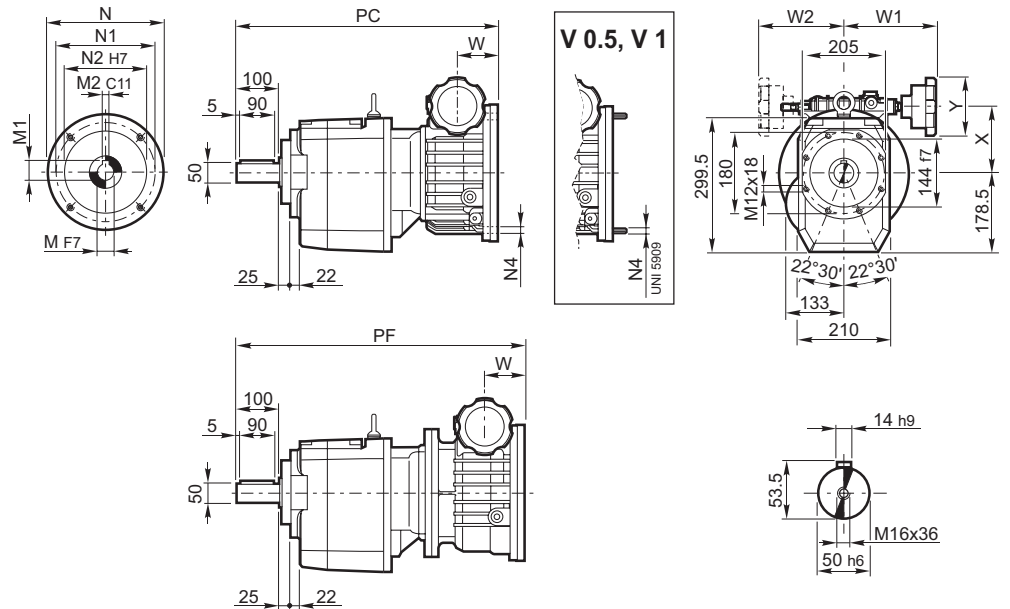

## C 61\_UF + V\_P(IEC)

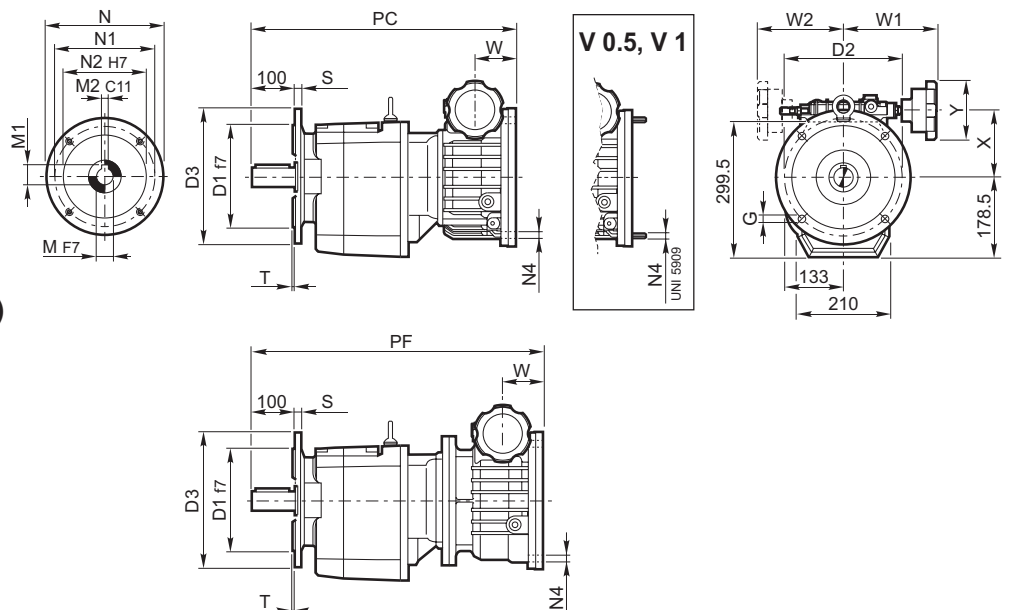

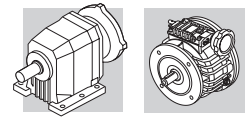

UF			D <sub>1</sub>	D <sub>2</sub>	D <sub>3</sub>	G	T	S
C 612_UFA	C 613_UFA	C 614_UFA	230	265	300	14	4	16
C 612_UFB	C 613_UFB	C 614_UFB	250	300	350	18	5	18

	IEC	V_C - V_F											C 61_ + V_C			C 61_ + V_F				
		N	N1	N2	N4	M	M1	M2	W	W1	W2	X	Y	PC	$\overset{\text{Kg}}{\text{P}}$	$\overset{\text{Kg}}{\text{U}}$	PF	$\overset{\text{Kg}}{\text{P}}$	$\overset{\text{Kg}}{\text{U}}$	
C 612_ V 1	P80	200	165	130	M10x20	19	21.8	6	59	133	124	97	83	—	—	—	574	72	67	
C 613_ V 1	P90	200	165	130	M10x20	24	26.3**	8	59	133	124	97	83	—	—	—	574	72	67	
	V 2	P90	200	165	130	M10x15	24	27.3	8	74.1	137	120	113	83	519	71	66	598	77	72
	V 3	P100	250	215	180	M12x23	28	31.3	8	91	172.5	—	150.5	109	555	93	85	675	101	96
	V 3	P112	250	215	180	M12x23	28	31.3	8	91	172.5	—	150.5	109	555	93	85	675	101	96
	V 5.5	P112	250	215	180	M12x23	28	31.3	8	91	172.5	—	150.5	109	555	94	86	675	102	97
	V 10	P132	300	265	230	M12x25	38	41.3	10	108	193.5	—	206.5	109	581	149	141	739	162	157
C 614_ V 0.5	P71	160	130	110	M8x20	14	16.3	5	47.5	115	110	78	83	532	75	67	598	71	63	
	V 0.5	P80	200	165	130	M10x20	19	20.8*	6	51.5	115	110	78	83	536	75	67	602	71	63
	V 1	P80	200	165	130	M10x20	19	21.8	6	59	133	124	97	83	560	82	74	644	81	73
	V 1	P90	200	165	130	M10x20	24	26.3**	8	59	133	124	97	83	560	82	74	644	81	73
	V 2	P90	200	165	130	M10x15	24	27.3	8	74.1	137	120	113	83	583	86	78	668	86	78

\* Utilizzare linguetta ribassata di ns. fornitura 6x5x30 "A"

\* Use thin parallel key 6x5x30 "A" supplied by Bonfiglioli

\* Den bei uns verfügbaren flachen Federkeil "A" 6x5x30 verwenden

\* Utiliser une languette abaissée de notre fabrication 6x5x30 "A"

\*\* Utilizzare linguetta ribassata di ns. fornitura 8x6x35 "A"

\*\* Use thin parallel key 8x6x35 "A" supplied by Bonfiglioli

\*\* Den bei uns verfügbaren flachen Federkeil "A" 8x6x35 verwenden

\*\* Utiliser une languette abaissée de notre fabrication 8x6x35 "A"

## C 61\_ + V\_P + BN

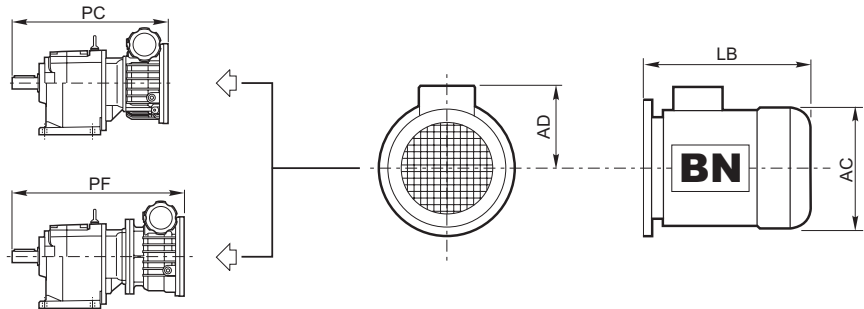

	IEC	BN			C 61_ + V_C			C 61_ + V_F			
		AC	AD	LB	PC+LB	$\overset{\text{Kg}}{\text{P}}$	$\overset{\text{Kg}}{\text{U}}$	PF+LB	$\overset{\text{Kg}}{\text{P}}$	$\overset{\text{Kg}}{\text{U}}$	
C 612_ V 1	80	156	119	234	—	—	—	808	82	77	
C 613_ V 1	90S	176	133	276	—	—	—	850	84.4	79.4	
	90L	176	133	276	—	—	—	850	86.4	81.4	
	V 2	90S	176	133	276	794.5	83.1	75.1	874	89.1	84.1
	V 2	90L	176	133	276	794.5	85.1	77.1	874	91.1	86.1
	V 2	100R	195	142	307	825.5	93.1	85.1	905	99.1	94.1
	V 3	100	195	142	307	862	113	105	982	121	116
	V 3	112	219	157	325	880	123	115	1000	131	126
	V 5.5	112	219	157	325	880	124	116	1000	132	127
	V 10	132S	258	193	413	994	192	184	1151.5	205	200
	V 10	132M	258	193	413	994	202	194	1151.5	215	210
C 614_ V 0.5	71	138	108	219	750.5	80.9	72.9	817	76.4	68.4	
	V 0.5	80	156	119	234	769.5	84.9	76.9	836	80.4	72.4
	V 1	80	156	119	234	794	91.9	83.9	878	91	83
	V 1	90S	176	133	276	836	94.3	86.3	920	93.4	85.4
	V 1	90L	176	133	276	836	96.3	88.3	920	95.4	87.4
	V 2	90S	176	133	276	859	98.3	90.3	944	98.1	90.1
	V 2	90L	176	133	276	859	100.3	92.3	944	100.1	92.1
	V 2	100R	195	142	307	890	108.3	100.3	975	108.1	100.1

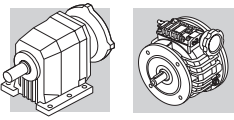

# C 70

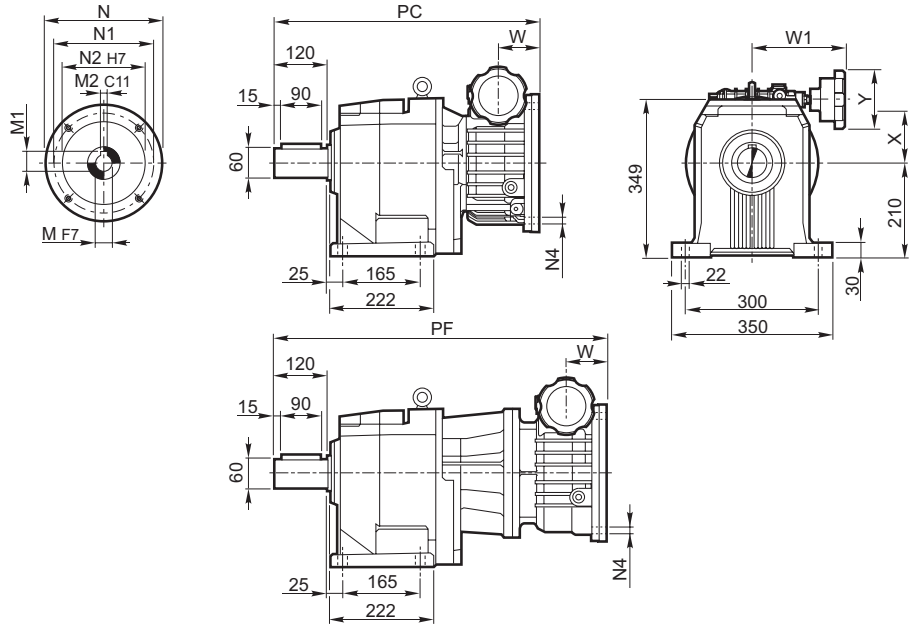

**C 70\_P + V\_P(IEC)**

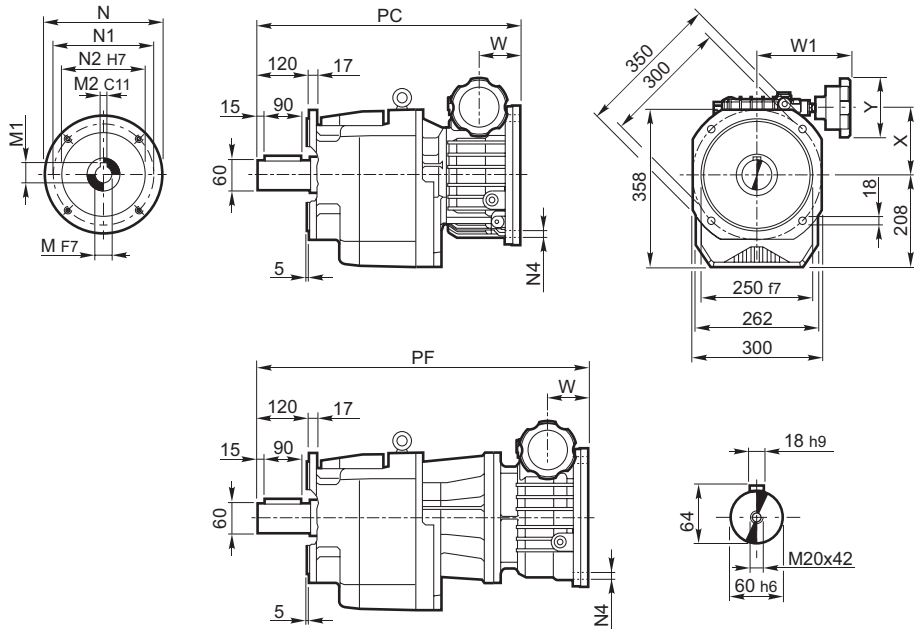

**C 70\_F + V\_P(IEC)**

	IEC	V_C - V_F													C 70_ + V_C		C 70_ + V_F			
		N	N1	N2	N4	M	M1	M2	W	W1	W2	X	Y	PC	Kg	PF	Kg			
		P	F	P	F															
C 702_	V 3	P100	250	215	180	M12x23	28	31.3	8	91	172.5	—	150.5	109	604	115	115	707	131	131
	V 5.5	P112	250	215	180	M12x23	28	31.3	8	91	172.5	—	150.5	109	604	116	116	707	132	132
	V 10	P132	300	265	230	M12x25	38	41.3	10	108	193.5	—	206.5	109	—	—	—	776	192	192
C 703_	V 2	P90	200	165	130	M10x15	24	27.3	8	74.1	137	120	113	83	—	—	—	634	107	107
	V 3	P100	250	215	180	M12x23	28	31.3	8	91	172.5	—	150.5	109	604	116	116	707	131	131
	V 5.5	P112	250	215	180	M12x23	28	31.3	8	91	172.5	—	150.5	109	604	117	117	707	132	132
	V 10	P132	300	265	230	M12x25	38	41.3	10	108	193.5	—	206.5	109	—	—	—	776	192	192



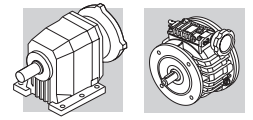

## C 70\_ + V\_P + BN

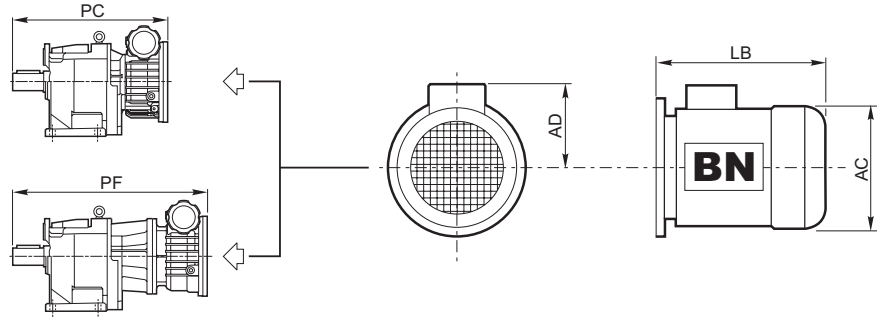

	IEC	BN			C 70_ + V_C			C 70_ + V_F			
		AC	AD	LB	PC+LB	Kg		PF+LB	Kg		
						P	F		P	F	
C 702_	V 3	100	195	142	307	911	142	142	1014	158	158
	V 3	112	219	157	325	929	153	153	1032	169	169
	V 5.5	112	219	157	325	929	154	154	1032	170	170
	V 10	132S	258	193	413	—	—	—	1189	244	244
	V 10	132M	258	193	413	—	—	—	1189	262	262
C 703_	V 2	90S	176	133	276	—	—	—	910	119	119
	V 2	90L	176	133	276	—	—	—	910	121	121
	V 2	100R	195	142	307	—	—	—	941	129	129
	V 3	100	195	142	307	911	143	143	1014	158	158
	V 3	112	219	157	325	929	154	154	1032	169	169
	V 5.5	112	219	157	325	929	155	155	1032	170	170
	V 10	132S	258	193	413	—	—	—	1189	244	244
	V 10	132M	258	193	413	—	—	—	1189	262	262

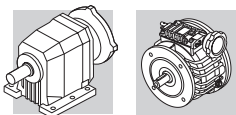

# C 80

## C 80\_P + V\_P(IEC)

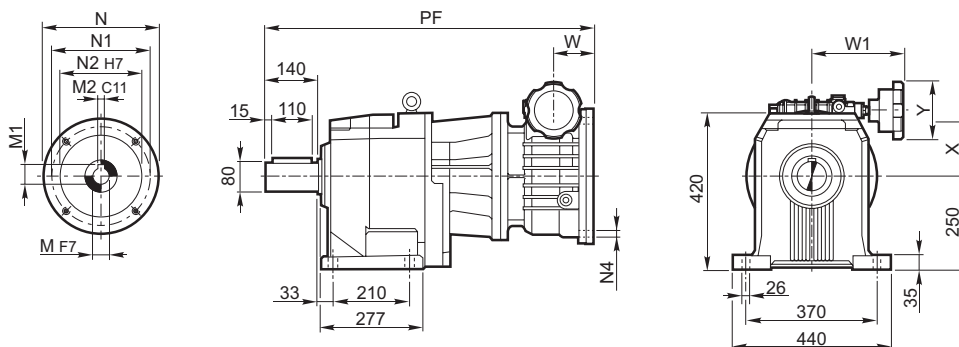

## C 80\_F + V\_P(IEC)

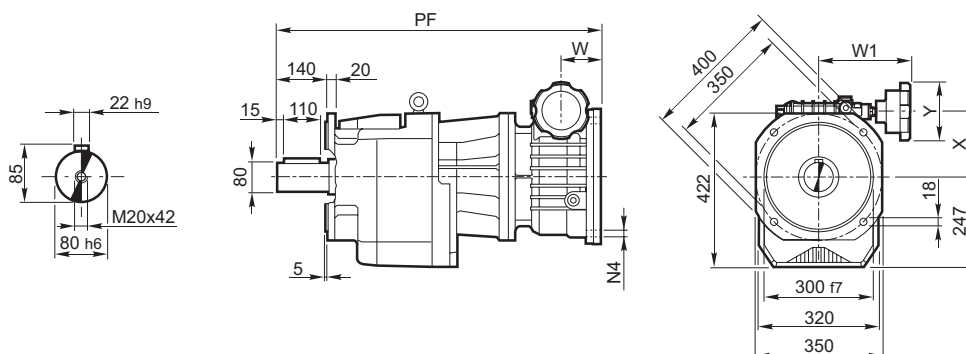

	IEC	V_C - V_F												C 80_ + V_C		C 80_ + V_F				
		N	N1	N2	N4	M	M1	M2	W	W1	W2	X	Y	PC	Kg		PF	Kg		
															P	F	P	F	F	
C 802_	V 5.5	P112	250	215	180	M12x23	28	31.3	8	91	172.5	—	150.5	109	—	—	—	768	179	177
	V 10	P132	300	265	230	M12x25	38	41.3	10	108	193.5	—	206.5	109	—	—	—	837	238	236
C 803_	V 2	P90	200	165	130	M10x15	24	27.3	8	74.1	137	120	113	83	—	—	—	695	157	155
	V 3	P100	250	215	180	M12x23	28	31.3	8	91	172.5	—	150.5	109	—	—	—	768	178	176
	V 5.5	P112	250	215	180	M12x23	28	31.3	8	91	172.5	—	150.5	109	—	—	—	768	179	177
	V 10	P132	300	265	230	M12x25	38	41.3	10	108	193.5	—	206.5	109	—	—	—	837	238	236

## C 80\_ + V\_P + BN

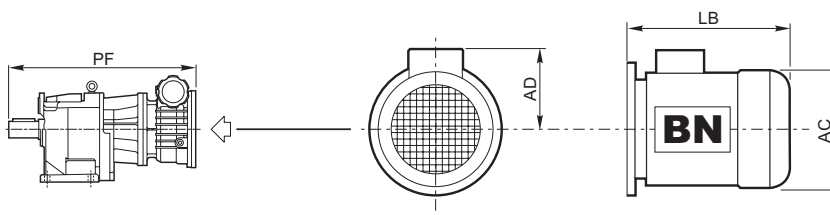

	IEC	BN			C 80_ + V_C			C 80_ + V_F			
		AC	AD	LB	PC+LB	Kg		PF+LB	Kg		
					P	F		P	F	F	
C 802_	V 5.5	112	219	157	325	—	—	—	1093	217	215
	V 10	132S	258	193	413	—	—	—	1250	290	288
	V 10	132M	258	193	413	—	—	—	1250	308	306
C 803_	V 2	90S	176	133	276	—	—	—	971	172	170
	V 2	90L	176	133	276	—	—	—	971	177	175
	V 2	100R	195	142	307	—	—	—	1002	184	182
	V 3	100	195	142	307	—	—	—	1075	205	203
	V 3	112	219	157	325	—	—	—	1093	216	214
	V 5.5	112	219	157	325	—	—	—	1093	217	215
	V 10	132S	258	193	413	—	—	—	1250	290	288
	V 10	132M	258	193	413	—	—	—	1250	308	306

# C 90

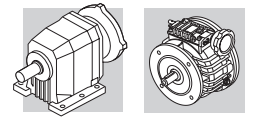

## C 90\_P + V\_P(IEC)

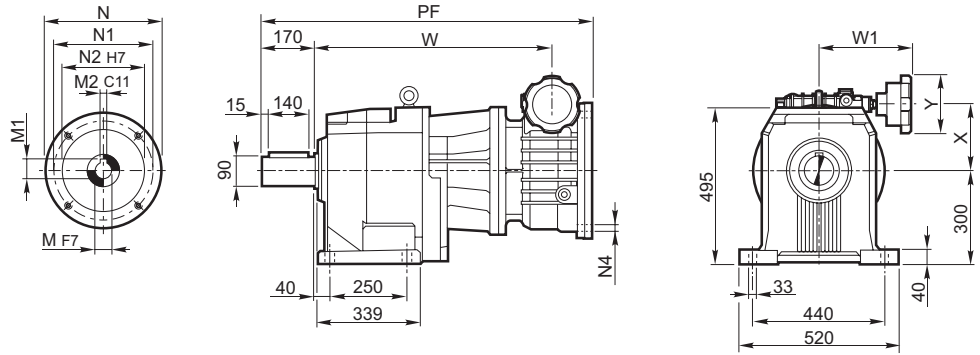

## C 90\_F + V\_P(IEC)

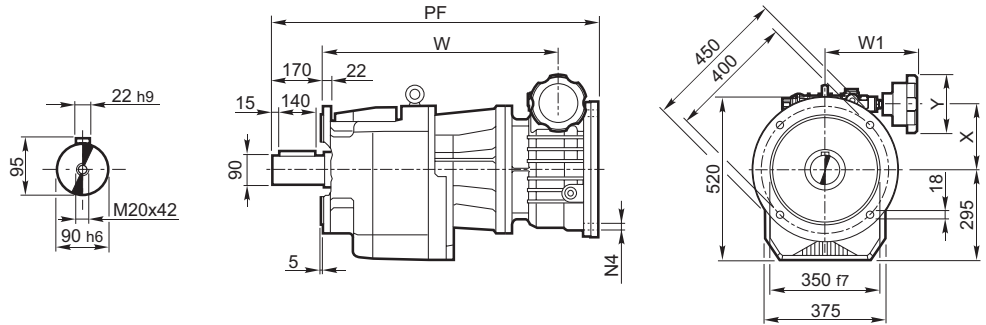

	IEC	V_C - V_F											C 90_ + V_C			C 90_ + V_F			
		N	N1	N2	N4	M	M1	M2	W	W1	X	Y	PC	Kg		PF	Kg		
														P	F		P	F	
C 902_	V 10	P132	300	265	230	M12x25	38	41.3	10	108	193.5	206.5	109	—	—	—	947	333	325
C 903_	V 3	P100	250	215	180	M12x23	28	31.3	8	91	172.5	150.5	109	—	—	—	878	273	264
	V 5.5	P112	250	215	180	M12x23	28	31.3	8	91	172.5	150.5	109	—	—	—	878	274	265
	V 10	P132	300	265	230	M12x25	38	41.3	10	108	193.5	206.5	109	—	—	—	947	333	325

## C 90\_ + V\_P + BN

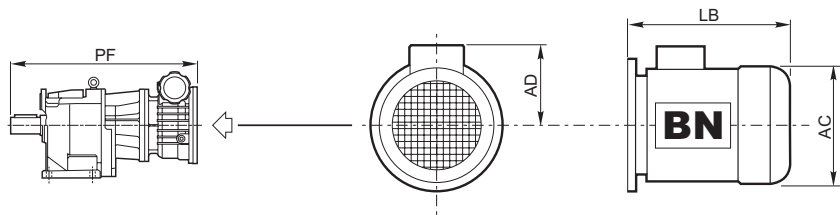

	IEC	BN			C 90_ + V_C				C 90_ + V_F		
		AC	AD	LB	PC+LB	Kg		PF+LB	Kg		
						P	F		P	F	
C 902_	V 10	132S	258	193	413	—	—	—	1360	385	377
	V 10	132M	258	193	413	—	—	—	1360	403	395
C 903_	V 3	100	195	142	307	—	—	—	1185	300	291
	V 3	112	219	157	325	—	—	—	1203	311	302
	V 5.5	112	219	157	325	—	—	—	1203	312	303
	V 10	132S	258	193	413	—	—	—	1360	385	377
	V 10	132M	258	193	413	—	—	—	1360	403	395

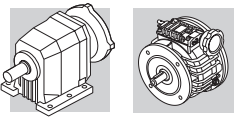

# C 100

## C 100\_P + V\_P(IEC)

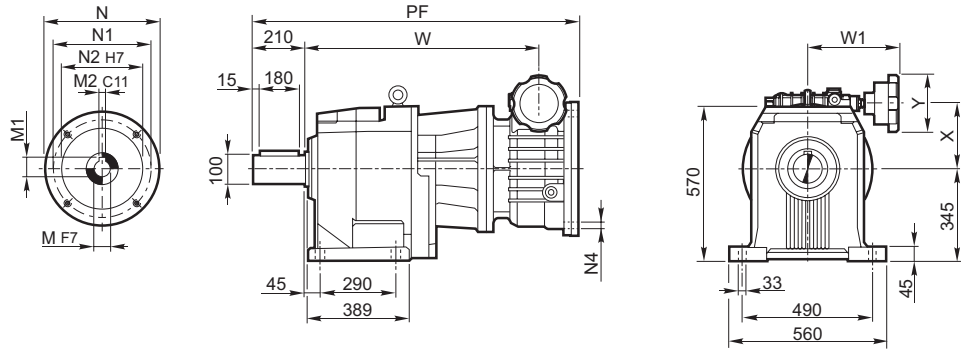

## C 100\_F + V\_P(IEC)

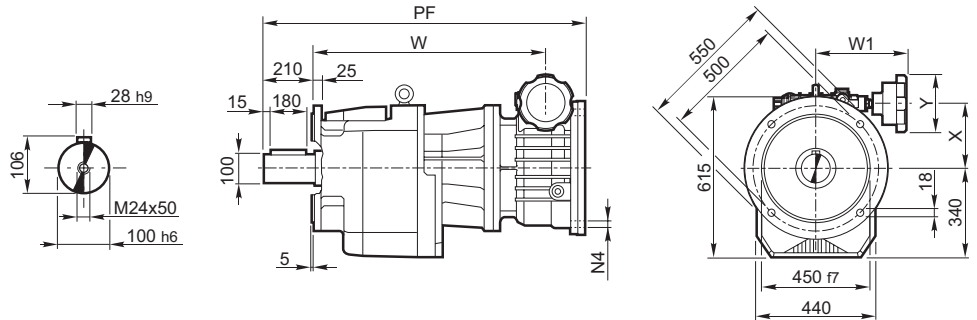

	IEC	V_C - V_F											C 100_ + V_C		C 100_ + V_F			
		N	N1	N2	N4	M	M1	M2	W	W1	X	Y	PC	P	F	PF	P	F
C1003_ V 10	P132	300	265	230	M12x25	38	41.3	10	108	193.5	206.5	109	—	—	—	1042	464	458

## C 100\_ + V\_P + BN

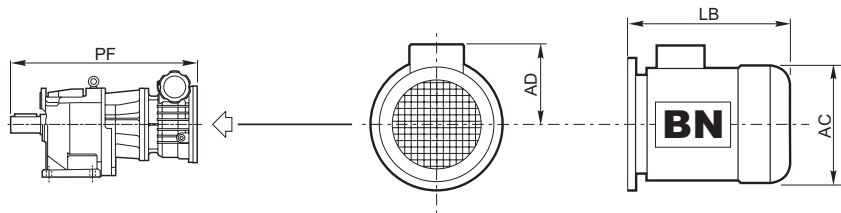

	IEC	BN			C 100_ + V_C				C 100_ + V_F		
		AC	AD	LB	PC+LB	P	F	PF+LB	P	F	
C1003_ V 10	132S	258	193	413	—	—	—	1455	516	510	
C1003_ V 10	132M	258	193	413	—	—	—	1455	534	528	

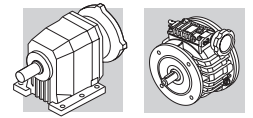

**C\_ + V\_**

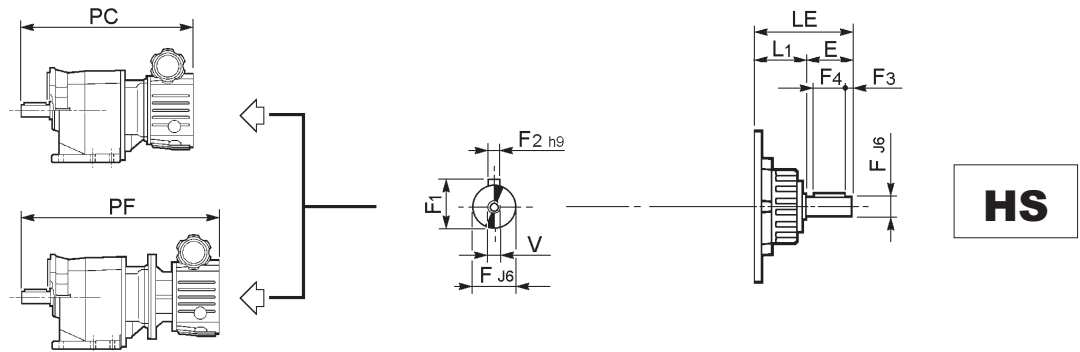

	E	F	F1	F2	F3	F4	LE	L1	V	Kg
<b>V 0.25</b>	23	11	12.5	4	2	20	58.5	35.5	M4	1.1
<b>V 0.5</b>	30	14	16	5	2.5	25	67	37	M5	1.6
<b>V 1</b>	40	19	21.5	6	5	30	88.5	48.5	M6	2.8
<b>V 2</b>	50	24	27	8	5	40	103.5	53.5	M8	4.0
<b>V 3</b>	60	28	31	8	5	50	121.5	61.5	M10	7.0
<b>V 5.5</b>	60	28	31	8	5	50	121.5	61.5	M10	7.0
<b>V 10</b>	80	38	41	10	5	70	160.5	80.5	M12	11.0

**C\_ + V\_**

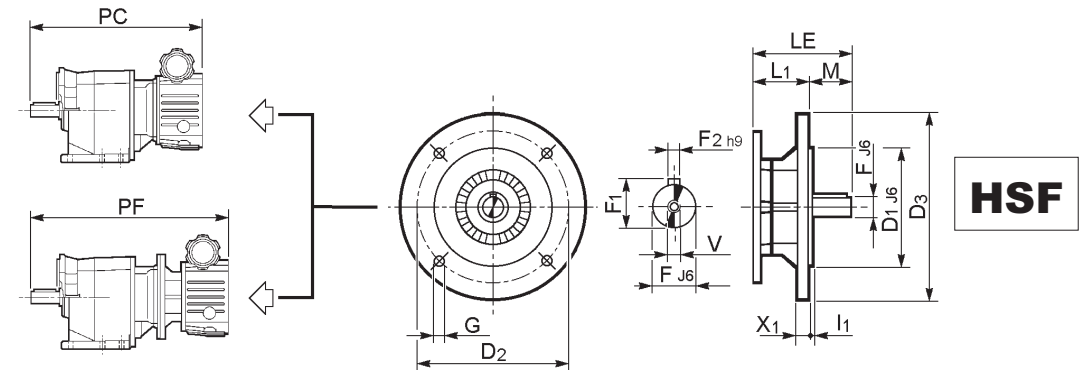

	D1	D2	D3	F	F1	F2	G	I1	LE	L1	M	V	X1	Kg
<b>V 0.25</b>	95	115	140	11	12.5	4	8.5	3	58.5	37.5	21	M4	8	1.6
<b>V 0.5</b>	110	130	160	14	16	5	8.5	3.5	67	37	30	M5	8	2.5
<b>V 1</b>	130	165	200	19	21.5	6	11.5	3.5	88.5	48.5	40	M6	12	4.5
<b>V 2</b>	130	165	200	24	27	8	11.5	3.5	103.5	53.5	50	M8	12	5.9
<b>V 3</b>	180	215	250	28	31	8	14	4	121.5	61.5	60	M10	14	11.0
<b>V 5.5</b>	180	215	250	28	31	8	14	4	121.5	61.5	60	M10	14	11.0
<b>V 10</b>	230	265	300	38	41	10	14	5	160.5	80.5	80	M12	16	20

**C\_ + V\_**

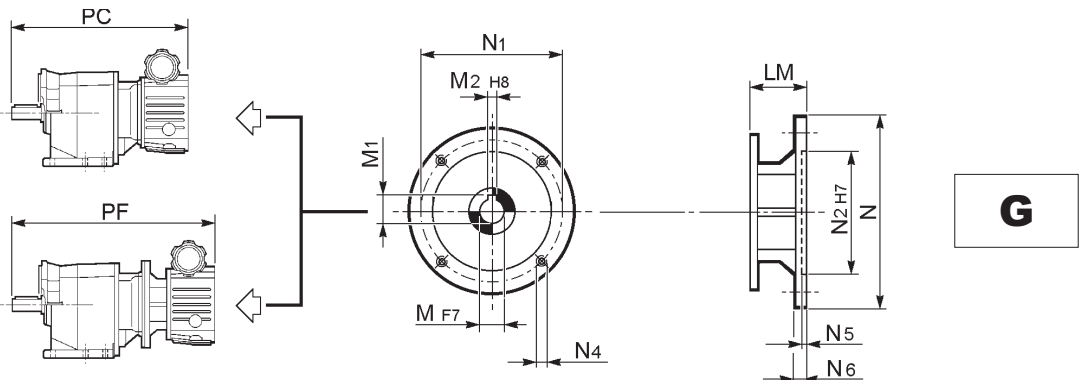

	LM	M	M1	M2	N	N1	N2	N4	N5	N6	Kg
<b>V 0.25 G71</b>	42	14	16.3	5	160	130	110	M8	4.5	11	1.8
<b>V 0.5 G80</b>	54	19	21.8	6	200	165	130	M10	4.5	11.5	2.8
<b>V 1 G90</b>	59	24	27.3	8	200	165	130	M10	4.5	11.5	5.0
<b>V 2 G112</b>	67	28	31.3	8	250	215	180	M12	5	14	6.8
<b>V 3 G132</b>	88.5	38	41.3	10	300	265	230	M12	5	15	12.0
<b>V 5.5 G132</b>	88.5	38	41.3	10	300	265	230	M12	5	15	12.0
<b>V 10 G160</b>	120	42	45.3	12	350	300	250	M16	6	18	22

N.B. I pesi riportati in questa pagina si riferiscono alle sole entrate.

NOTE: Weights reported in this page refer to input module.

HINWEIS: Die in dieser Tabelle angegebenen Gewichte beziehen sich nur auf den Antrieb.

N.B. : Les poids indiqués à cette page se réfèrent uniquement aux entrées.

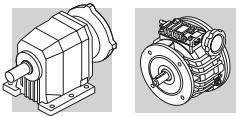

**VD**

**VD\_F\_P(IEC)**

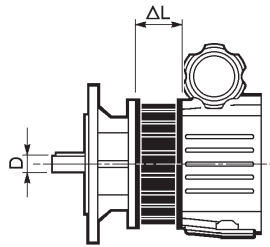

N.B. Le dimensioni mancanti sono riportate nelle pagine 184-203.

*Note: missing dimensions are indicated on pages 184-203.*

ACHTUNG: Die fehlenden Maße werden auf den Seiten 184-203 angegeben.

N.B. : Les dimensions manquantes sont indiquées pages 184-203.

	<b>D</b>	<b>ΔL</b>	<b>Kg</b>
<b>VD 0.5_P_</b>	14	69	3.1
<b>VD 1_P_</b>	19	80.5	4.7
<b>VD 2_P_</b>	24	89.5	7.7
<b>VD 3_P_</b>	28	100.4	16.3
<b>VD 5.5_P_</b>	28	100.4	16.3
<b>VD 10_P_</b>	38	119.2	27.7

N.B. Il differenziale è applicabile esclusivamente ai variatori nella forma costruttiva UF. I pesi riportati in tabella si riferiscono al solo differenziale.

*NOTE: Differential will only fit UF type variators. Weights refer to differential only.*

HINWEIS: Das Differential kann ausschließlich nur an den Verstellgetrieben der Bauform UF appliziert werden. Die in dieser Tabelle angegebenen Gewichte beziehen sich nur auf das Differential.

N.B. : Le différentiel est applicable uniquement aux variateurs dans la forme de construction UF. Les poids indiqués à cette page se réfèrent uniquement au différentiel.

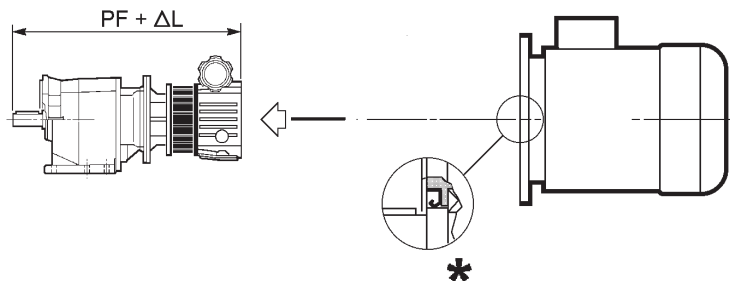

\* Nei variatori con differenziale, quando il motore elettrico è installato dall'utente, è necessario verificare che esso sia dotato di un anello di tenuta olio sull'albero montato secondo lo schema e che la flangia sia stagna. La tenuta olio fra la flangia motore e la flangia variatore è assicurata da una guarnizione fornita di serie sul variatore stesso.

*\* On fitting the electric motor onto variators featuring the differential unit make sure that the electric motor itself is oiltight and an oil seal is provided on drive end shaft. Sealing between flange of motor and variator is ensured by a gasket provided with the variator unit.*

\* Wenn der Elektromotor vom Kunden angebaut wird, ist es bei den Verstellgetrieben mit Differential erforderlich, die Motorwelle mit einem öldichten Wellendichtring auszustatten. Die Abdichtung zwischen Motor- und Verstelltriebflansch wird durch eine Dichtung gewährleistet, die beim Verstellgetriebe serienmäßig mitgeliefert wird.

\* Sur les variateurs avec différentiel, lorsque le moteur électrique est installé par l'utilisateur, il est nécessaire de vérifier qu'il soit doté d'une bague d'étanchéité sur l'arbre monté selon le schéma. L'étanchéité à l'huile entre la bride moteur et la bride variateur est assurée par un joint fourni de série et présent sur le variateur.

N.B. Le dimensioni e i pesi dei motori elettrici sono riportati nelle pag. 338-356.

*N.B. Dimensions and weights of electric motors are listed at page 338-356.*

ACHTUNG: Die Maße und Gewichte der Elektromotoren werden auf den Seiten 338-356 aufgeführt.

N.B. : Les dimensions et les poids des moteurs électriques sont indiqués à pages 338-356.

**Accessori:**

- CGY
- KITCGY
- ENTHS
- ENTG
- ENTN
- INDGRAV

Vedi pag. 88-94

**Accessories:**

- CGY
- KITCGY
- ENTHS
- ENTG
- ENTN
- INDGRAV

See page 88-94

**Zubehör:**

- CGY
- KITCGY
- ENTHS
- ENTG
- ENTN
- INDGRAV

Siehe Seite 88-94

**Accessoires:**

- CGY
- KITCGY
- ENTHS
- ENTG
- ENTN
- INDGRAV

Voir page 88-94

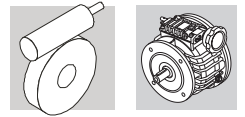

**23.0 - MOTOVARIARIDUTTORI**  
***GEARED MOTOVARIATORS***  
***VERSTELLGETRIEBEMOTOREN***  
***MOTOVARIAREDUCTEURS***

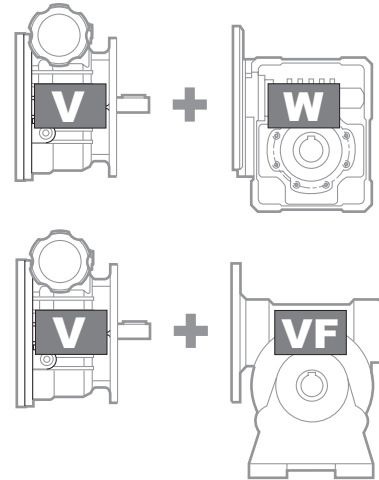

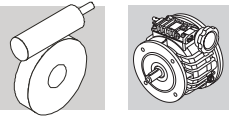

23.1 - Designazione riduttore

23.1 - Gearbox designation

23.1 - Getriebebezeichnung

23.1 - Désignation réducteur

**VF 49 L1 F1**  **28 V B3** .....

OPZIONI / OPTIONS  
OPTIONEN / OPTIONS

POSIZIONE DI MONTAGGIO / MOUNTING POSITION  
EINBAULAGEN / POSITION DE MONTAGE

**B3** (VF44, VF49)  
**B3** (Standard), **B6, B7, B8, V5, V6**

221

DESIGNAZIONE INGRESSO / INPUT DESIGNATION  
BEZEICHNUNG DER ANTRIEBSSEITE / DESIGNATION ENTREE

**V** + grandezza variatore = Predisposto per variatore compatto  
**V** + variator size = suitable to fit compact variator  
**V** + Verstellgetriebegröße = für kompaktes Verstellgetriebe geeignet  
**V** + grandeur variateur = prédisposé pour variateur compact

V025	V05	V1	V2	V3	V55	V10
V 0.25	V 0.5	V 1	V 2	V 3	V 5.5	V 10

**P** + grandezza motore = Predisposto per variatore flangiato  
**P** + motor size = suitable to fit flanged output variator  
**P** + Motorgröße = für geflanshtes Verstellgetriebe geeignet  
**P** + taille moteur = prédisposé pour variateur avec bride

P63	P71	P80	P90	P100	P112	P132
V 0.25	V 0.5	V 0.5 V 1	V 1 V 2	V 3	V 5.5	V 10

RAPPORTO DI RIDUZIONE / GEAR RATIO  
ÜBERSETZUNG / RAPPORT DE REDUCTION

DIAMETRO ALBERO LENTO / OUTPUT SHAFT DIAMETER  
DURCHMESSER DER ABTRIEBSWELLE / DIAMETRE ARBRE LENT

Solo per Only for Nur für Seulement pour	W 75	<b>D30</b> (default)
		<b>D28</b> (Su richiesta / on request / Option / sur demande)

FORMA COSTRUTTIVA / VERSION / BAUFORM / FORME DE CONSTRUCTION

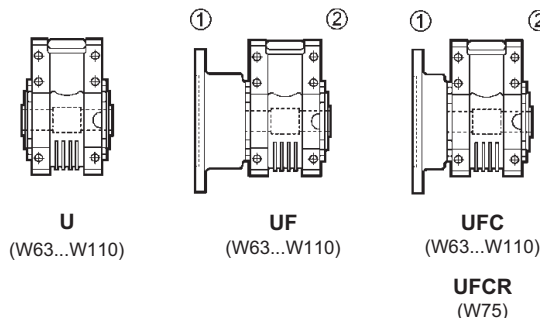
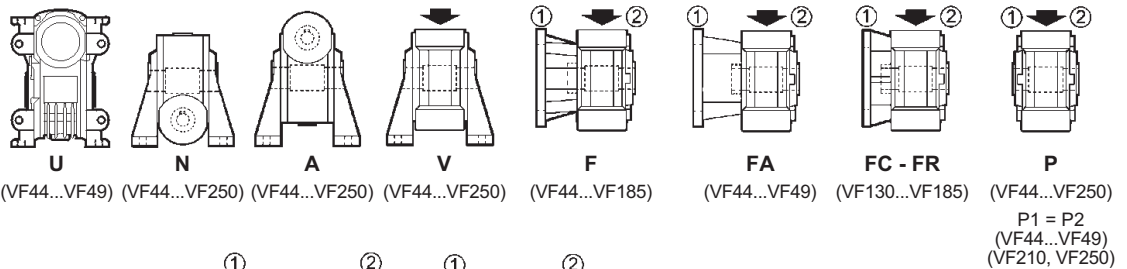

① - ② Lato fissaggio flangia / Flange mounting side  
Flansch Fixierungsseite / Position de la bride

LIMITATORE DI COPPIA / TORQUE LIMITER / DREHMOMENTBEGRENZER / LIMITEUR DE COUPLE  
L1, L2

GRANDEZZA RIDUTTORE / GEARBOX SIZE  
GETRIEBEBAUGRÖSSE / TAILLE REDUCTEUR  
44, 49, 130, 150, 185, 210, 250 (VF)  
63, 75, 86, 110 (W)

TIPO RIDUTTORE / GEARBOX TYPE / GETRIEBETYP / TYPE DE REDUCTEUR:

**VF, W** = Riduttore a vite senza fine / Worm gearbox / Schneckengetriebe / Réducteur a vis sans fin



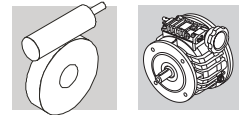

23.2 - Designazione variatore

23.2 - Designation of variator

23.2 - Bezeichnung für Drehzahlwandler

23.2 - Désignation variateur

**V**  **0.5** **C**   **P71** **B3** **1** **PDN** **SCT** ....

OPZIONI / OPTIONS  
OPTIONEN / OPTIONS

TIPO DI COMANDO / REMOTE CONTROL TYPE  
VERSTELLEINRICHTUNG / TYPE DE COMMANDE  
**A, VG, VA, VAG, SCT (3Ø), TC (1Ø)**

SONDA RILEVATRICE / SPEED SENSOR  
MEßSONDE / SONDE DE DETECTION  
**PDN, PDNA, PDP**

POSIZIONE DISPOSITIVO DI COMANDO / SPEED KNOB POSITION  
EINBAULAGE DER VERSTELLEINRICHTUNG / POSITION COMMANDE  
**1 (default), 2 (V 3...V 10)**

POSIZIONE DI MONTAGGIO / MOUNTING POSITION  
MOTOR BAUFORM / FORME DE CONSTRUCTION DU MOTEUR  
**B3 (default), B6, B7, B8, V5, V51, V52, V53, V6, V61, V62, V63**

221

CONFIGURAZIONE INGRESSO / INPUT CONFIGURATION  
BEZEICHNUNG DER ANTRIEBSSEITE / DESIGNATION ENTREE

- P (IEC)** - predisposizione IEC / Provided with IEC motor adaptor  
vorbereitet für den Anbau eines IEC-Motors / prédisposé IEC
- HS** - albero cilindrico / solid input shaft / freier Antriebswelle / arbre rapide sortant
- HSF** - albero cilindrico e flangia riportata / solid input shaft and bolt-on flange  
freier Antriebswelle und Flansch / arbre rapide sortant et adjonction de bride
- N (NEMA)** - predisposizione motore NEMA / provided with Nema motor adaptor  
vorbereitet für den Anschluß eines NEMA-Motors / prédisposé moteur NEMA
- G (IEC)** - flangia IEC maggiorata / provided with IEC extended adaptor  
mit zusätzlicher Baueinheit für IEC-Motore / avec module supplémentaire prédisposé IEC

DIAMETRO ALBERO LENTO / OUTPUT SHAFT BORE  
ABTRIEBSWELLE DURCHMESSER / DIAMETRE ARBRE LENT

**D +** diametro in mm / diameter in mm  
Durchmesser in mm / diamètre en mm **(11,14,...)**

<b>D11</b>	<b>D14</b>	<b>D19</b>	<b>D24</b>	<b>D28</b>	<b>D28</b>	<b>D38</b>
(V 0.25)	(V 0.5)	(V 1)	(V 2)	(V 3)	(V 5.5)	(V 10)

**IMP** albero in pollici / inch series shaft / Nema-Welle / arbre NEMA

TIPO DI FISSAGGIO (per gruppi tipo U) / OUTPUT CONFIGURATION (only for U version)  
MONTAGEMÖGLICHKEIT (ausschließlich für die Bauform U) / TIPE DE FIXATION (pour forme de construction U)

- F (IEC)** - flangia IEC riportata / bolt-on IEC flange / Flansch IEC / adjonction de bride IEC
- F (NEMA)** - flangia NEMA / NEMA flange mounted / NEMA Flansch / bride Nema

FORMA COSTRUTTIVA / VERSION / BAUFORM / VERSION

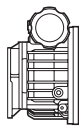

**C**

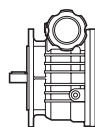

**F**

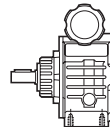

**U**

GRANDEZZA VARIATORE / VARIATOR SIZE / BAUGRÖSSE / TAILLE VARIATEUR  
**0.25, 0.5, 1, 2, 3, 5.5, 10**

DIFFERENZIALE / DIFFERENTIAL / DIFFERENTIAL / DIFFERENTIEL  
**D**

VARIATORE / VARIATOR TYPE / VERSTELLGETRIEBETYP / TYPE VARIATEUR  
**V**

23.3 - Designazione motore

23.3 - Motor designation

23.3 - Motor bezeichnung

23.3 - Désignation moteur

25

25

25

25

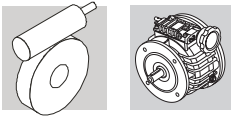

### 23.4 - Opzioni riduttori

**SO**  
I riduttori VF 44, VF 49, W 63 ... W 86, solitamente riempiti in fabbrica di lubrificante, sono in questo caso forniti privi di olio.

**LO**  
I riduttori delle grandezze da VF 130 a VF 250 e W 110, solitamente sprovvisti di lubrificante, sono richiesti con olio sintetico del tipo correntemente utilizzato da BONFIGLIOLI RIDUTTORI e riempiti in accordo alla posizione di montaggio specificata. L'applicabilità dell'opzione LO è descritta nella tabella seguente.

### 23.4 - Gearbox options

**SO**  
Gear units VF 44, VF 49 and W 63 ... W 86, usually factory filled with oil, are, in this case, supplied unlubricated.

**LO**  
Gearboxes VF 130...VF 250 and W 110, usually supplied unlubricated, to be filled with synthetic oil currently used by BONFIGLIOLI RIDUTTORI according to the mounting position specified. The applicability of the LO option is described in the table below.

### 23.4 - Getriebe Optionen

**SO**  
Die Getriebe VF 44, VF 49 und W 63 ... W 86, das normalerweise sind mit Schmiermittel geliefert, werden ohne Öl geliefert.

**LO**  
Die normalerweise ohne Schmiermittel gelieferten Getriebe vom VF 130...VF 250 und W 110, die gewöhnlich ohne Schmiermittel geliefert werden, in Übereinstimmung mit der Einbaulage gefüllt mit dem normalerweise von BONFIGLIOLI RIDUTTORI verwendeten synthetischen Schmierstoff. Die Anwendbarkeit der Option LO wird in der folgenden Tabelle näher erläutert.

### 23.4 - Options réducteurs

**SO**  
Les réducteurs VF 44, VF 49, W 63 ... W 86, habituellement fournis avec lubrifiant, sont livrés sans huile.

**LO**  
Les réducteurs VF 130...VF 250 et W 110, habituellement dépourvus de lubrifiants, sont demandés avec huile synthétique du type couramment utilisé par BONFIGLIOLI RIDUTTORI et remplis conformément à la position de montage demandée. L'applicabilité de l'option LO est décrite dans le tableau suivant.

	LO					
	Posizione di montaggio / Mounting position / Einbaulage / Position de montage					
	B3	B6	B7	B8	V5	V6
W 110 U-UF-UFC	X	X	X	X	⊖	⊖
VF 130 A-N-P-F-FC	X	X	X	X	⊖	⊖
VF 130 V	⊖	X	X	⊖	X	X
VF 130 FR	X	⊖	⊖	X	⊖	⊖
VF 150 A-N-P-F-FC	X	X	X	X	⊖	⊖
VF 150 V	⊖	X	X	⊖	X	X
VF 150 FR	X	⊖	⊖	X	⊖	⊖
VF 185 A-N-P-F-FC	X	X	X	X	⊖	⊖
VF 185 V	⊖	X	X	⊖	X	X
VF 185 FR	X	⊖	⊖	X	⊖	⊖
VF 210 A-N-P	X	⊖	⊖	X	⊖	⊖
VF 210 V	⊖	⊖	⊖	⊖	X	X
VF 250 A-N-P	X	⊖	⊖	X	⊖	⊖
VF 250 V	⊖	⊖	⊖	⊖	X	X

**RB**  
Albero veloce sporgente sul lato opposto comando.

**PV**  
Fornitura di anelli di tenuta in fluoro-elastomero sia sull'albero lento sia sull'albero veloce.

**KA**  
Kit piedi W 63...W 110 per intercambiabilità con gruppi equivalenti VF\_A.

**KV**  
Kit piedi W 63...W 110 per intercambiabilità con gruppi equivalenti VF\_V. (escluso W con opzione RB).

**RB**  
Double-ended input shaft at non-drive-end.

**PV**  
Oil seals from Fluoro elastomer compound on both the input and the output shaft.

**KA**  
VF\_A interchangeability kit. Option is available for units W 63 to W 110.

**KV**  
VF\_V interchangeability kit (barring W 7 option RB). Option is available for units W 63 to W 110.

**RB**  
Zweites Wellenende gegenüber von Eigangswelle.

**PV**  
Alle Wellendichtringen aus Fluor-Elastomer.

**KA**  
Durch mit VF\_A austauschbarem Satz - Abstellfüße komplettiert.

**KV**  
Durch mit VF\_V austauschbarem Satz - Abstellfüße komplettiert (W mit Option RB ausgeschlossen).

**RB**  
Vis saillante sur le côté opposé commande.

**PV**  
Les réducteurs sont équipées de bagues d'étanchéité en Elastomère fluoro soi sur l'arbre se sortie que sur l'arbre d'entrée.

**KA**  
Kit pieds pour interchangeabilité avec groupe équivalent type VF\_A.

**KV**  
Kit piedes pour interchangeabilité avec groupe équivalent type VF\_V (a l'exclusion de W avec option RB).

### 23.5 - Opzioni variatori

**CU**  
Cassa universale con piano di appoggio spianato e relativi fori di fissaggio (pag. 28).

**FL**  
Cassa universale con fianchi laterali spianati e relativi fori di fissaggio (pag. 28).

**PDN**  
Predisposizione al rilevamento di giri digitale incorporato all'interno del variatore con sonda rilevatrice di tipo NPN.

**PDP**  
Predisposizione al rilevamento di giri digitale incorporato all'interno del variatore con sonda rilevatrice di tipo PNP.

La tabella (F01) riporta le possibilità di applicazione e le dimensioni delle sonde NPN e PNP utilizzate.

### 23.5 - Variator options

**CU**  
Universal casing featuring machined supporting surface with drilled and tapped holes (page 28).

**FL**  
Universal casing featuring machined sides with drilled and tapped holes (page 28).

**PDN**  
Configured for digital speed detection by NPN sensor incorporated into variator.

**PDP**  
Configured for digital speed detection by PNP sensor incorporated into variator.

Table (F01) shows which units support which options and provides the (plug thread) dimensions of the various NPN and PNP sensors used.

### 23.5 - Optionen – Verstelltriebemotor

**CU**  
Universalgehäuse mit plangeschliffener Auflagefläche und entsprechenden Befestigungsbohrungen (Seite 28).

**FL**  
Universalgehäuse mit plangeschliffenen Seitenflanken und entsprechenden Befestigungsbohrungen (Seite 28).

**PDN**  
Vorbereitet für im Verstellgetriebe eingebaute digitale Vorrichtung für die Drehzahlerhebung über eine NPN-Sonde.

**PDP**  
Vorbereitet für im Verstellgetriebe eingebaute digitale Vorrichtung für die Drehzahlerhebung über eine PNP-Sonde.

In der Tabelle (F01) werden die möglichen Applikationsmöglichkeiten der verwendeten NPN- und PNP-Sonden aufgeführt.

### 23.5 - Options variateurs

**CU**  
Caisse universelle avec plan d'appui aplati et orifices de fixation correspondants (page 28).

**FL**  
Caisse universelle avec flancs latéraux aplatis et orifices de fixation correspondants (page 28).

**PDN**  
Prédisposition pour le dispositif de mesure du nombre de tours digital incorporé à l'intérieur du variateur avec sonde de détection de type NPN.

**PDP**  
Prédisposition pour le dispositif de mesure du nombre de tours digital incorporé à l'intérieur du variateur avec sonde de détection de type PNP.

Le tableau (F01) indique les différentes possibilités d'application ainsi que les dimensions des sondes NPN et PNP utilisées.

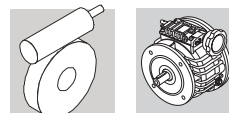

(F01)

Riduttore Gearbox Getriebe Réducteur	Sonda Plug thread Sonde Sonde (NPN/PNP)	Variatore Variator Verstellgetriebe Variateur	Forme costruttive / Versions Bauformen / Formes de construction		
			C	V	V_D UF
VF 44	M8x1	V 0.25	#		—
VF 49	M8x1	V 0.25	#		—
	M8x1	V 0.5	#		
W 63	M8x1	V 0.5	#		
	M10x1	V 1	#		
W 75	M8x1	V 0.5	#		
	M10x1	V 1	#		
W 86	M8x1	V 2	#		
		V 0.5	#		
	M10x1	V 1	#		
		V 2	#		

Applicazioni disponibili

# Applicazione disponibile per le posizioni di montaggio B3, a richiesta (come esecuzione speciale) per le altre posizioni di montaggio.

PV

Anelli di tenuta in fluoro-elastomero.

SO

I variatori V 0.25 - V 15 solitamente forniti con lubrificante dalla Bonfiglioli Riduttori sono forniti privi di lubrificante. Questa opzione non è prevista per i variatori con differenziale V 0.5D - V 10D con ingresso P.. in quanto normalmente forniti privi di lubrificante.

### 23.6 - Lubrificazione

#### Lubrificazione riduttori serie VF e W

I gruppi VF 44, VF 49, W 63 ... W 86 sono normalmente consegnati con carica di lubrificante del tipo "long life" dalla fabbrica, o dalla rete di vendita ufficiale. Su richiesta gli stessi riduttori possono essere forniti privi di lubrificante, specificando per questi l'opzione SO. L'applicabilità dell'opzione è descritta nel capitolo "OPZIONI RIDUTTORE".

I gruppi VF 130 ... VF 250 e W 110 sono normalmente forniti privi di lubrificante e sarà cura dell'utilizzatore riempirli di olio prima della messa in servizio.

Per questi stessi gruppi è disponibile l'opzione LO che, qualora specificata in fase di ordinativo, garantisce il primo riempimento in fabbrica con lubrificante sintetico, in quantità dipendente dalla posizione di montaggio. L'applicabilità dell'opzione è descritta nel capitolo "OPZIONI RIDUTTORE".

Le tavole che seguono sono da riferimento nell'interpretazione delle posizioni di montaggio, della collocazione dei tappi di servizio e delle quantità di lubrificante. Queste ultime sono indicative, e per il corretto riempimento si dovrà fare riferimento alla mezzera del tappo, o dell'astina di livello, se presente. Rispetto a questa condizione la quantità di lubrificante riportata in tabella può presentare scostamenti, occasionalmente anche rilevanti.

Option availability

# The provision is available for variator in the B3 mounting position alone. Enquire with Bonfiglioli for different requirements.

PV

Fluoro elastomer seals.

SO

The V 0.25 - V 15 variators - normally factory-filled with oil - are supplied dry. This option is not available on the V 0.5D - V 10D variators with differential unit and P input, that are normally supplied unlubricated.

### 23.6 - Lubrication

#### Lubrication of VF and W gearboxes

Frame sizes VF 44, VF 49, W 63 ... W 86 are supplied by the factory, or by authorized dealers, already filled with "long life" synthetic oil. On request, these units can be supplied unlubricated, in which case, the option SO must be specified on the order. The applicability of the option is described in the chapter "GEARBOX OPTIONS".

Unless otherwise specified, units type VF 130 ... VF 250 and W 110 are generally supplied unlubricated at it is the customer's responsibility to fill them with oil prior to putting them into operation. By requesting the LO option at the time of order, these units will be factory filled with synthetic lubricant in the quantity relevant to the mounting position that was specified in the purchase order. The applicability of the option is described in the chapter "GEARBOX OPTIONS".

The charts below must be referred to for the mounting position and related oil plugs, if applicable, as well as the lubricant quantity.

Oil quantities are approximate only. For correct filling always refer to the centre of the sight glass or the dipstick, when this is supplied. In some cases, even substantial discrepancies may occur compared to the oil quantities listed in the chart.

Riduttore Gearbox Getriebe Réducteur	Sonda Plug thread Sonde Sonde (NPN/PNP)	Variatore Variator Verstellgetriebe Variateur	Forme costruttive / Versions Bauformen / Formes de construction		
			C	V	V_D UF
W 110	M10x1	V 1	#		
		V 2	#		
VF 130	M10x1	V 3/5.5	—		
		V 2	#		
VF 150	M12x1	V 3/5.5	—		
		V 10	—		
VF 185	M12x1	V 3/5.5	—		
		V 10	—		
VF 210	M12x1	V 10	—		
VF 250	M12x1	V 10	—		

Zur Verfügung stehende Anwendungen

# Anwendung auch für die Montagepositionen B3 erhältlich; auf Anfrage (als Sonderausführung) auch für die anderen Montagepositionen.

PV

Dichtringe in Fluor-Elastomer.

SO

Die üblicherweise von der Bonfiglioli Riduttori mit Schmiermittel gelieferten Verstellgetriebe V 0.25 - V 15 werden bei dieser Ausführungsart ohne Schmiermittel geliefert. Diese Option ist bei den Verstellgetrieben mit Antrieb P.. V 0.5D - V 10D mit Differential nicht gegeben, da diese normalerweise ohne Schmiermittel geliefert werden.

### 23.6 - Schmierung

#### Schmierung der Getriebe der Serie VF und W

Die Getriebegrößen VF 44, VF 49, W 63 ... W 86 sind bei der Lieferung ab Werk bzw. ab offiziellem Verkaufszentrum mit einer synthetischen "Long-Life" -Dauerschmierung versehen. Auf Anfrage können die oben benannten Einheiten auch ohne Öl geliefert werden. Hier muss bei der Bestellung die Option SO angegeben werden.

Die Anwendbarkeit der Option wird im Kapitel „GETRIEBE OPTIONEN“ näher erläutert. Falls nicht anders spezifiziert werden die Getriebe VF 130 ... VF 250 und W 110 grundsätzlich ohne Ölfüllung ausgeliefert. Vor der Inbetriebnahme muss das Getriebe kundenseitig mit der richtigen Ölfüllmenge befüllt werden. Sollten Sie diese Getriebe mit der Option LO bestellen, werden die Einheiten direkt vom Werk aus mit synthetischem Öl, gemäß der spezifizierten Einbaulage, befüllt. Die Anwendbarkeit der Option wird im Kapitel „GETRIEBE OPTIONEN“ näher erläutert. Die folgenden Tabellen dienen für die Interpretation der Einbaulagen, für die Anbringung der Stopfen und der Ölfüllmengen.

Die angegebene Ölfüllmengen sind Anhaltswerte! Je nach Einbaulage muss das Getriebe bis zur Mitte des Stopfens bzw., falls vorhanden, des Pegelstabes befüllt werden. Bitte beachten Sie, dass die tatsächlichen Füllmengen u.U. stark von den Tabellenwerten abweichen können.

Applications disponibles

# Application disponible pour les positions de montage B3, sur demande (exécution spéciale) pour les autres positions de montage.

PV

Bagues d'étanchéité en Elastomère fluoré.

SO

Les variateurs V 0.25-V 15 généralement fournis avec du lubrifiant par Bonfiglioli Riduttori sont fournis sans lubrifiant. Cette option n'est pas prévue pour les variateurs avec différentiel V 0.5D - V 10D avec entrée P.. dans la mesure où il sont normalement fournis sans lubrifiant.

### 23.6 - Lubrification

#### Lubrification réducteurs Série VF et W

Les groupes VF 44, VF 49, W 63 ... W 86 sont normalement livrés par l'usine, ou par le réseau de vente officiel, avec une charge de lubrifiant synthétique. Sur demande les mêmes réducteurs peuvent être fournis sans lubrifiant, en spécifiant l'option SO. L'applicabilité de l'option est décrite dans le chapitre « OPTIONS REDUCTEURS ».

Les groupes VF 130 ... VF 250 et W 110 sont normalement fournis sans lubrifiant, le remplissage précédent être fourni sans lubrifiant, en précisant l'option LO lors de la commande, ces groupes seront remplis d'huile synthétique en usine, avec la quantité correspondant à la position de montage. L'applicabilité de l'option est décrite dans le chapitre « OPTIONS REDUCTEURS ».

Les tables suivantes sont la référence dans l'interprétation des positions de montage, le placement des bouchons de service et pour la quantité de lubrifiant.

Ces dernières sont indicatives, et pour un remplissage correct il faut faire référence au milieu du bouchon de niveau ou à la jauge à huile, si présents. Par rapport à cette condition la quantité de lubrifiant indiqué dans le tableau peut présenter des écarts, occasionnellement considérables.

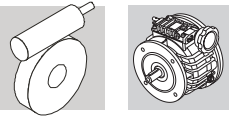

Il lubrificante "long life" fornito di serie è di natura sintetica e, a meno di contaminazione dall'esterno, non richiede sostituzioni periodiche per tutto l'arco di vita del riduttore.

Il funzionamento dei riduttori è ammesso per temperature ambiente comprese fra -20°C e +40°C. Per temperature ambiente comprese fra -20°C e -10°C l'avviamento del riduttore potrà avvenire solo dopo aver effettuato un pre-riscaldamento progressivo ed omogeneo del gruppo, oppure con funzionamento "a vuoto", senza carico collegato.

Il carico potrà poi essere applicato all'albero del riduttore quando la temperatura dello stesso avrà raggiunto la temperatura di -10°C, o superiore.

*In the absence of contamination, the "long life" synthetic lubricant supplied by the factory, does not require periodical changes throughout the lifetime of the gear unit.*

*Operation of gear units is permitted at ambient temperatures between -20°C and +40°C. However, for temperatures between -20°C and -10°C unit may only start up after it has been progressively and evenly pre-heated, or otherwise initially operated unloaded.*

*Load may then be connected to the output shaft when the gear unit has reached the temperature of -10°C, or higher.*

Die mit Lebensdauerschmierung gelieferten Getriebe sind mit synthetischem Öl auf Polyglykolbasis befüllt. Sollte das Öl nicht durch äußere Einwirkungen verunreinigt werden, benötigt das Getriebe über die gesamte Lebensdauer keinen Ölwechsel. Die Getriebe dürfen bei einer Umgebungstemperatur von -20°C bis +40°C betrieben werden. Allerdings darf ein Start unter Last bei -20°C bis -10°C erst nach stufenweiser und gleichmäßiger Vorwärmung erfolgen. Anderfalls muss das Anfahren ohne Last erfolgen. Die Last darf erst zugeschaltet werden, wenn die Getriebeeinheit eine Temperatur von mindestens -10° oder höher erreicht hat.

*Le lubrifiant "long life" ; fourni de série est de nature synthétique et, à moins de contamination par l'extérieur, il ne demande pas des remplacements périodiques pour toute la durée de vie du réducteur. Le même lubrifiant permet de fonctionner à des températures ambiantes comprises entre -20°C et +40°C. Pour des températures ambiantes comprises entre -20°C et -10°C le démarrage du réducteur est admis seulement après un préchauffage progressif et homogène, ou avec un fonctionnement « à vide », sans charge appliquée. La charge pourra être ensuite appliquée à l'arbre du réducteur quand celui-ci aura atteint une température de -10°C, ou supérieure.*

(F02)

Lubrificante di fornitura originale Bonfiglioli Riduttori / Original lubricant supplied by Bonfiglioli Riduttori Schmiermittel – Lieferzustand der Bonfiglioli Getriebe / Lubrifiant fourni à l'origine par Bonfiglioli Riduttori	
Riduttori a vite senza fine / Worm reducers Schneckengetriebe / Réducteurs à vis dans fin	<b>SHELL OMALA S4 WE 320</b>
Riduttori a vite s/fine con limitatore di coppia / Worm reducers with torque limiter Schneckengetriebe mit Drehzahlbegrenzer / Réducteurs à vis sans fin avec limiteur de couple	<b>SHELL OMALA S4 WE 460</b>

Bonfiglioli infine raccomanda che, qualora il lubrificante sia scelto al di fuori del tipo SHELL consigliato, questo sia di composizione equivalente in merito alla natura sintetica e alla viscosità, inoltre sia dotato degli opportuni additivi con funzione antischiama.

*Bonfiglioli finally recommends that, should a lubricant other than the approved Shell type be used, this be equivalent viscosity-wise and of the synthetic type. Lubricant must also have the necessary EP and anti-foaming additives.*

Bonfiglioli weist Sie letztendlich darauf hin, dass man in dem Fall, bei dem die Wahl der Schmiermittel nicht auf die empfohlene Marke SHELL trifft, ein in Bezug auf Viskosität und von der synthetischen Natur her gesehen gleichwertiges Schmiermittel verwenden sollte, das darüber hinaus mit den geeigneten Zusatzmitteln ausgestattet ist, die eine Schaumbildung verhindern.

*En fin, si le lubrifiant choisi n'est pas du type SHELL conseillé, Bonfiglioli recommande qu'il soit de composition équivalente en ce qui concerne la nature synthétique et la viscosité, de plus, il doit comprendre les additifs antimousse adaptés.*

Prima della messa in servizio rimuovere il tappo cieco e sostituirlo con il tappo dotato di sfiato, come indicato in figura.

*Prior to start-up make sure that the blind plug is replaced by the vented plug, as shown in the figure below.*

Vor der Inbetriebnahme, den Angaben in der Abbildung gemäß, Blindstopfen entfernen und durch die Entlüftungsschraube ersetzen.

*Avant la mise en service, enlever le bouchon bome et le remplacer par le bouchon de purge, comme indiqué sur la figure.*

(F03)

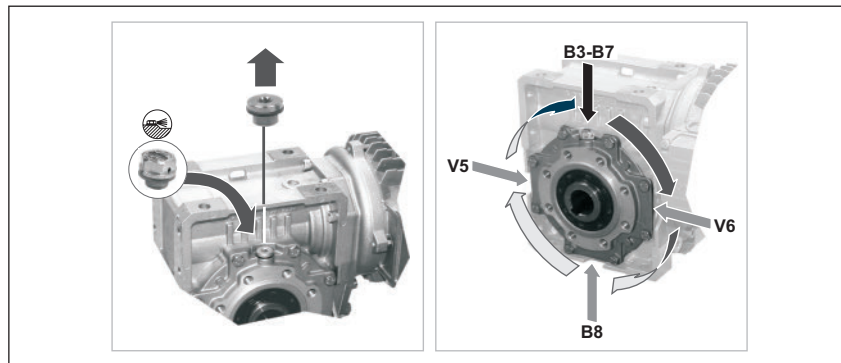

**VF 44, VF 49:** questi riduttori vengono forniti completi di olio in quantità tale da consentire l'installazione in qualsiasi posizione di montaggio.

*VF 44, VF 49: these units are factory-filled with oil which allows installation in any mounting position.*

**VF 44, VF 49:** Diese Getriebe werden komplett mit Öl geliefert, dessen Quantität ausreicht, dass die Installation in jeder beliebigen Einbaulage erfolgen kann.

*VF 44, VF 49: ces réducteurs sont fournis avec de l'huile en quantité suffisante pour permettre l'installation dans n'importe quelle position de montage.*

			[1]					
			B3	B6	B7	B8	V5	V6
<b>VF 44</b>	N - A - V - F - FA - P - U	HS - P(IEC)	0.075	0.075	0.075	0.075	0.075	0.075
<b>VF 49</b>	N - A - V - F - FA - P - U	HS - P(IEC)	0.12	0.12	0.12	0.12	0.12	0.12

Posizione di montaggio base.  
 Posizioni di montaggio derivate dalla posizione base B3.  
 Riduttori normalmente dotati di carica di lubrificante "a vita".

*Base mounting position.*  
*Mounting positions derived from base position B3.*  
*Life-time lubricated gear units.*

Grundeinbaulage.  
 Von der Grundeinbaulage B3 abgeleitete Einbaulagen.  
 Getriebe, zu deren normaler Ausstattung eine Schmierstoffladung für Dauerschmierung gehört.

*Position de montage de base.*  
*Positions de montage dérivées de la position de base B3.*  
*Réducteurs normalement livrés avec un plein de lubrifiant « à vie ».*

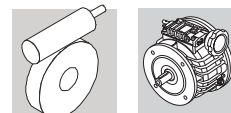

		[ ]					
		B3	B6	B7	B8	V5	V6
<b>W 63</b>	i = 7, 10, 12, 15	0.31	0.31	0.31	0.31	0.31	0.31
	i = 19, 24, 30, 38, 45, 64, 80, 100	0.38	0.38	0.38	0.38	0.38	0.38
<b>W 75</b>	i = 7, 10, 15	0.48	0.48	0.48	0.48	0.48	0.48
	i = 30, 40	0.52	0.52	0.52	0.52	0.52	0.52
	i = 20, 25, 50, 60, 80, 100	0.56	0.56	0.56	0.56	0.56	0.56
<b>W 86</b>	i = 7, 10, 15	0.64	0.64	0.64	0.64	0.64	0.64
	i = 30	0.73	0.73	0.73	0.73	0.73	0.73
	i = 20, 23, 40, 46, 56, 64, 80, 100	0.90	0.90	0.90	0.90	0.90	0.90
<b>W 110</b>	i = tutti / all / alle / tous	2.8	1.7	1.7	1.9	1.9	1.8

Riduttori normalmente dotati di carica di lubrificante "a vita".

Life-time lubricated gear units.

Getriebe, zu deren normaler Ausstattung eine Schmierstoffladung für Dauerschmierung gehört.

Réducteurs normalement livrés avec un plein de lubrifiant « à vie ».

			[ ]					
			B3	B6	B7	B8	V5	V6
<b>VF 130</b>	N		2.3	2.5	2.5	3.0	3.2	3.4
<b>VF 130</b>	V		3.4	2.5	2.5	3.1	3.0	2.5
<b>VF 130</b>	A - F - FC - FR - P	i = 7, 10, 15, 20, 23, 30, 40	3.0	2.5	2.5	2.3	3.3	3.3
<b>VF 130</b>	A - F - FC - FR - P	i = 46, 56, 64, 80, 100	3.9	2.5	2.5	2.3	3.3	3.3
<b>VF 150</b>	N		3.0	3.5	3.5	4.3	3.8	4.0
<b>VF 150</b>	V		4.0	3.5	3.5	3.6	4.3	3.0
<b>VF 150</b>	A - F - FC - FR - P	i = 7, 10, 15, 20, 23, 30, 40	4.3	3.5	3.5	3.0	3.9	3.9
<b>VF 150</b>	A - F - FC - FR - P	i = 46, 56, 64, 80, 100	4.5	3.5	3.5	3.0	3.9	3.9
<b>VF 185</b>	N		5.0	5.5	5.5	7.8	6.6	6.8
<b>VF 185</b>	V		6.8	5.5	5.5	6.4	7.8	5.4
<b>VF 185</b>	A - F - FC - FR - P		7.8	5.5	5.5	5.0	6.7	6.7
<b>VF 210</b>	N		7.5	9.5	9.5	7.3	9.2	9.0
<b>VF 210</b>	V		8.9	9.5	9.5	7.3	11	8.0
<b>VF 210</b>	A - F - FC - FR - P		11	9.5	9.5	7.5	9.4	8.9
<b>VF 250</b>	N		11	17	17	11	17	17
<b>VF 250</b>	V		17	17	17	11	23	11
<b>VF 250</b>	A - F - FC - FR - P		23	17	17	11	18	17

I valori delle quantità di olio riportati nelle tabelle sono da ritenersi indicativi; se si rende necessario un nuovo riempimento dei gruppi riferirsi sempre al livello visualizzato dalla mezzeria del tappo di livello.

The quantities of lubricant specified in the tables are only indicative. Correct level is at mid point of the level plug.

Bei den oben angegebenen Werten handelt es sich um Richtwerte. Sollte eine neue Füllung der Baugruppen erforderlich sein, muss man immer Bezug auf den an der Mittellinie der Ölstandsschraube angezeigten Pegel nehmen.

Les valeurs des quantités d'huile indiquées dans les tableaux sont indicatives; en cas de nécessité d'effectuer un nouveau remplissage, toujours se référer au niveau visualisé à la moitié du bouchon de niveau.

Collocazione dei tappi di carico, scarico e livello olio.

Positions of oil fill, level and drain plugs.

Anordnung des Einfüll-, Ölstands- und Ölablaßschrauben.

Position des bouchons de remplissage, niveau et vidange d'huile.

Legenda:	Key:	Zeichenerklärung:	Légende:
Tappo di sfiato / carico	Filling / breather plug	Einfüll / Ablasschraube	Bouchon de event / remplissage
Tappo di livello	Level plug	Ölstandsschraube	Bouchon de niveau
Tappo di scarico	Drain plug	Ölablaßschraube	Bouchon de vidange
Tappo in vista	Plug in sight	Sichtbarer Deckel	Bouchon visible
Tappo non in vista	Plug not in sight	Nicht sichtbarer Deckel	Bouchon non visible

Le pagine che seguono sono da riferimento per la collocazione dei tappi in relazione alla posizione di montaggio e ad altre variabili.

The following pages refer to plug position depending on reducer mounting position and other variables.

Die nachstehenden Seiten geben einen Hinweis in Bezug auf die Anordnung der jeweiligen Service-schrauben und die von der Einbaulage und anderen Variablen abhängige Schmiermittelmenge.

Les pages suivantes servent de référence pour le positionnement des bouchons de service en fonction de la position de montage et d'autres variables.

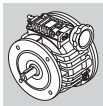
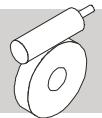

(F04)

# VF 44 ; VF 49

P (IEC)

V

A	<b>B3</b>	B7	V5		
	B6	B8	V6		
N	<b>B3</b>	B7	V5		
	B6	B8	V6		
V	<b>B3</b>	B7	V5		
	B6	B8	V6		
P	<b>B3</b>	B7	V5		
	B6	B8	V6		
F	<b>B3</b>	B7	V5		
	B6	B8	V6		
U	<b>B3</b>	B7	V5		
	B6	B8	V6		

Posizione di montaggio base. I riduttori sono targati esclusivamente nella posizione di montaggio base (B3) ma possono essere installati anche nelle posizioni derivate (B6, B7, B8, V5, V6). Dopo l'installazione la posizione di montaggio non può essere variata.

Base mounting position. Gearboxes are plated only for base mounting position (B3). They can nevertheless also be installed in any of the derived positions (B6, B7, B8, V5, V6). Mounting position may not be changed after installation.

Grundeinbaulage. Die Getriebe sind ausschließlich in der Grundeinbaulage (B3) beschildert; sie können aber auch in abgeleiteten Einbaulagen (B6, B7, B8, V5, V6) installiert werden. Nach der Installation ist es nicht möglich, die Einbaulage zu ändern.

Position de montage de base. Les réducteurs sont marqués exclusivement dans la position de montage de base (B3) mais ils peuvent être installés également dans des positions dérivées (B6, B7, B8, V5, V6). Après l'installation, la position de montage ne peut pas être modifiée.

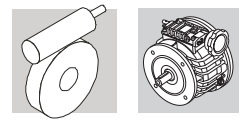

(F05)

**W 63 U ... W 86 U**

**W 63 UF/UFC ... W 86 UF/UFC**

**P (IEC)**

**V**

**P (IEC)**

**V**

**B3**

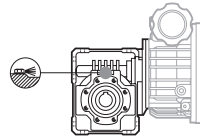
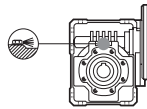
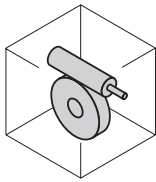

**B3**

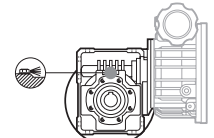
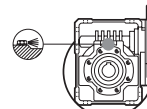
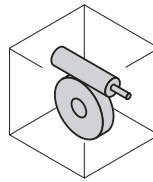

**B6**

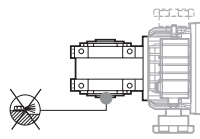
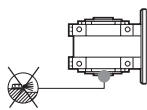
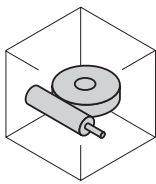

**B6**

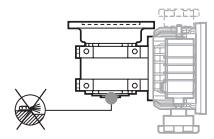
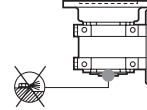
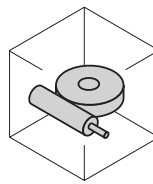

**B7**

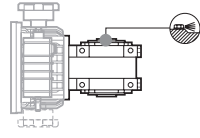
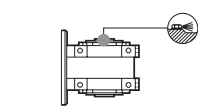
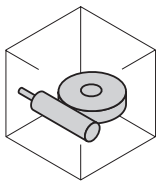

**B7**

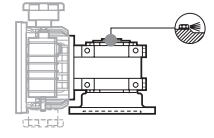
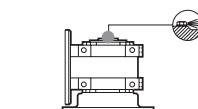
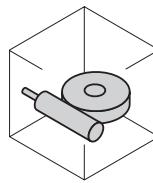

**B8**

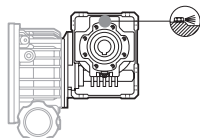
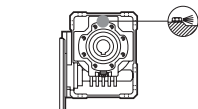
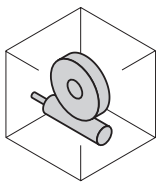

**B8**

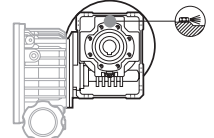
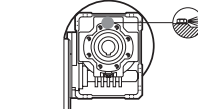
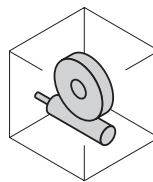

**V5**

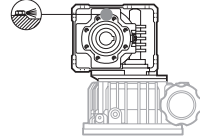
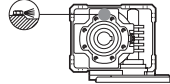
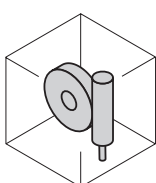

**V5**

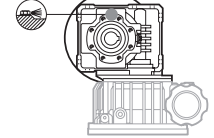
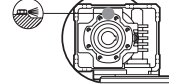
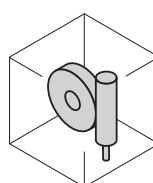

**V6**

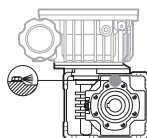
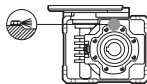
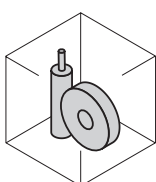

**V6**

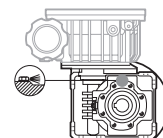
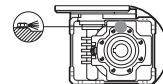
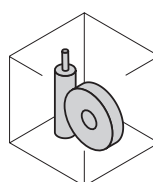

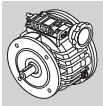
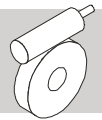

(F06)

## W 110 U

P (IEC)

V

B3

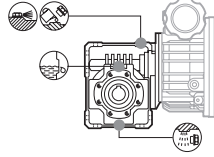
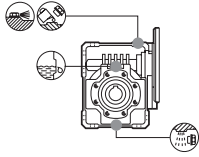
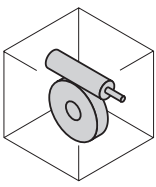

B6

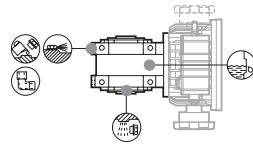
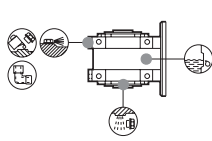
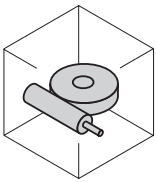

B7

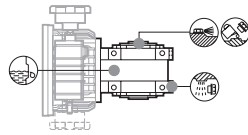
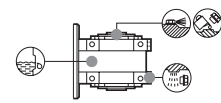
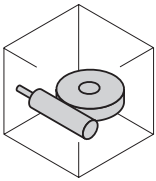

B8

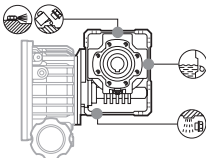
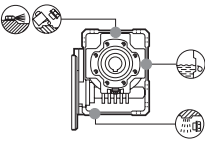
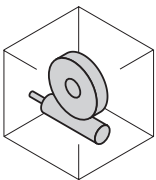

V5

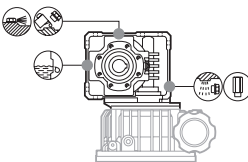
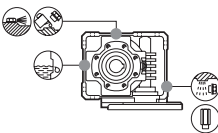
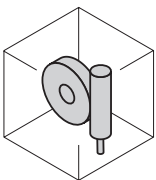

V6

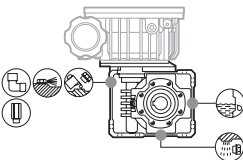
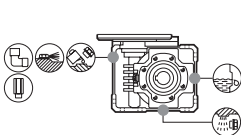
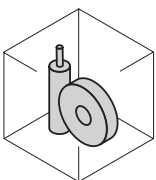

## W 110 UF/UFC

P (IEC)

V

B3

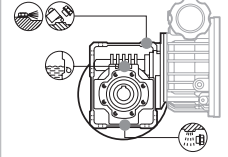
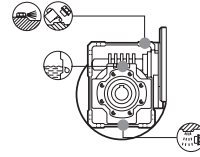
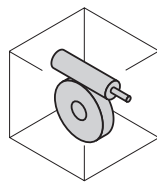

B6

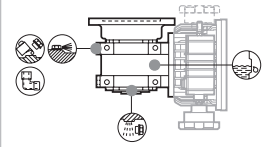
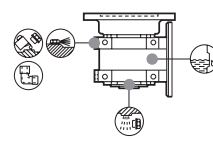
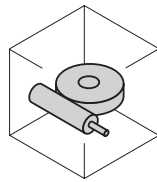

B7

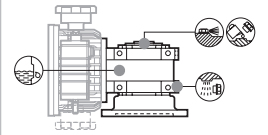
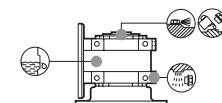
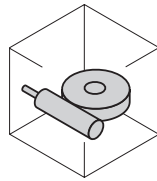

B8

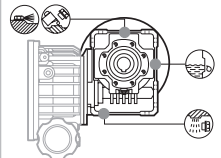
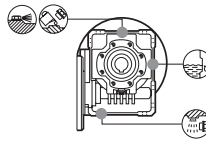
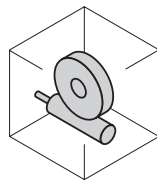

V5

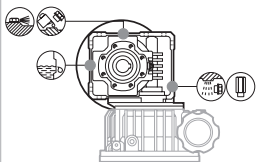
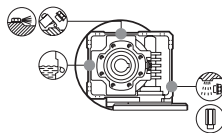
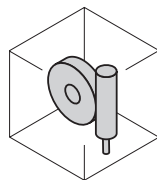

V6

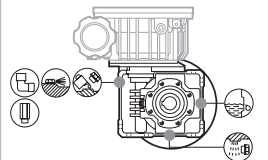
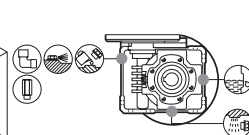
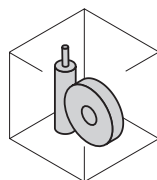



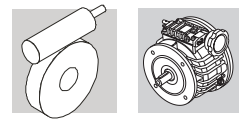

(F07)

## VF 130 A ... VF 250 A

P (IEC)

V

B3

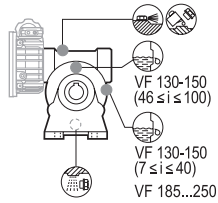
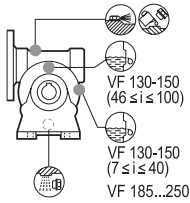
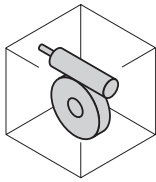

B6

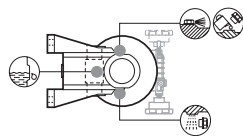
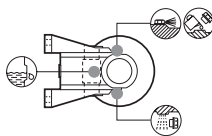
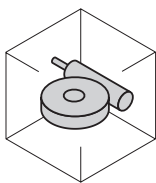

B3

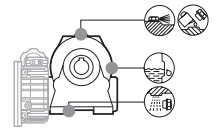
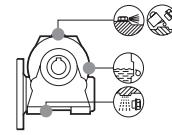
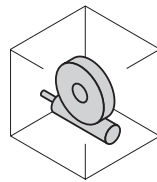

B6

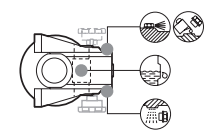
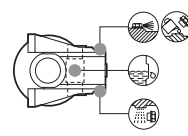
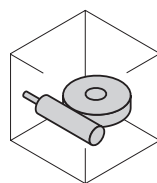

B7

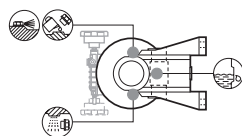
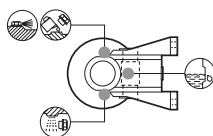
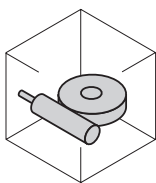

B7

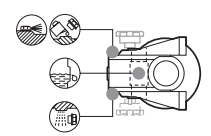
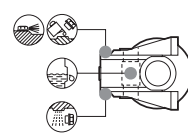
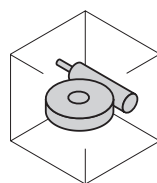

B8

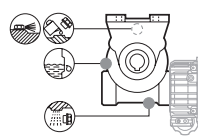
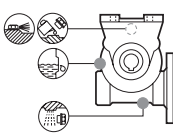
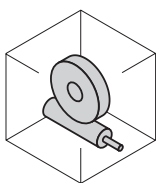

B8

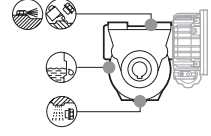
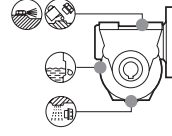
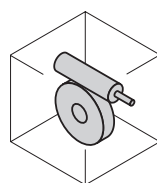

V5

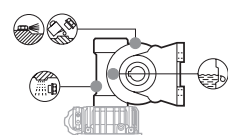
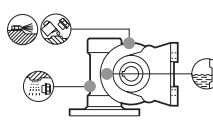
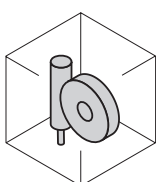

V5

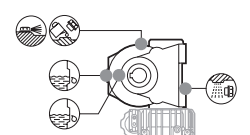
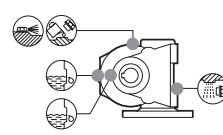
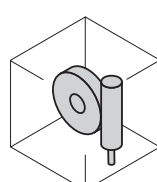

V6

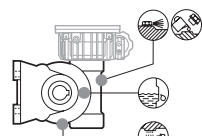
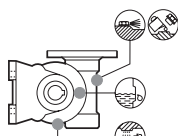
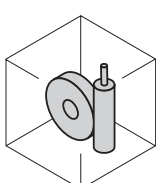

V6

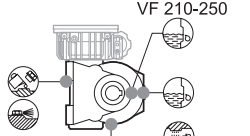
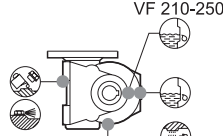
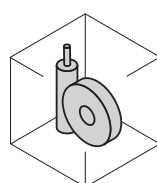

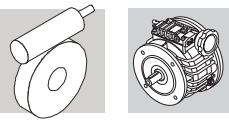

(F08)

## VF 130 V ... VF 250 V

P (IEC)

V

B3

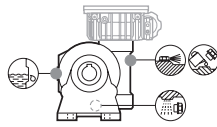
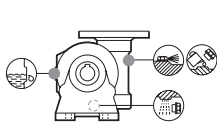
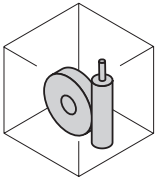

B6

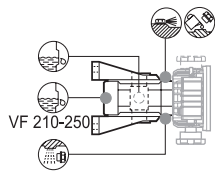
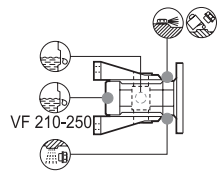
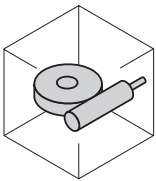

B7

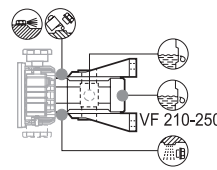
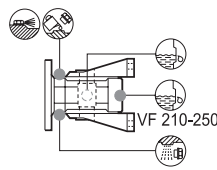
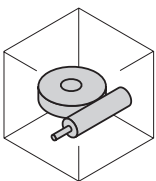

B8

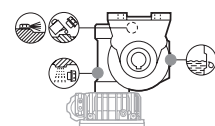
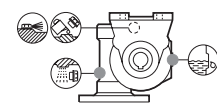
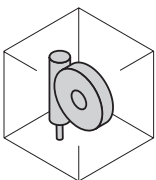

V5

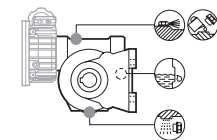
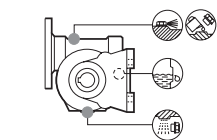
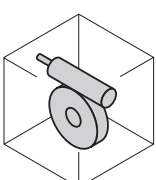

V6

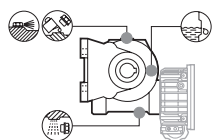
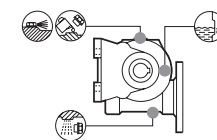
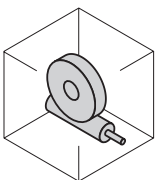

## VF 130 P ... VF 250 P

P (IEC)

V

B3

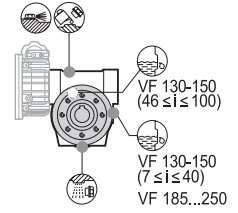
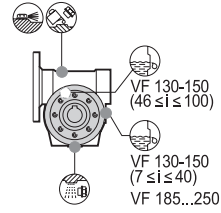
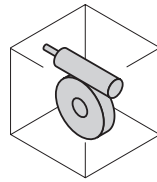

B6

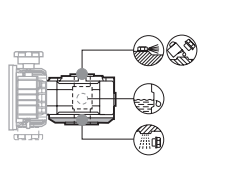
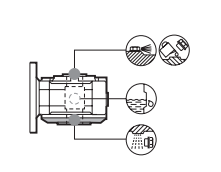
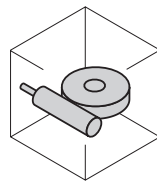

B7

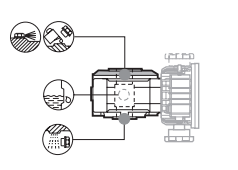
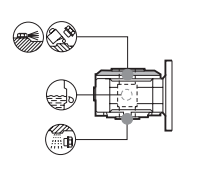
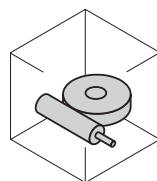

B8

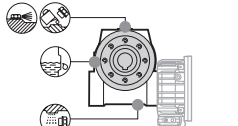
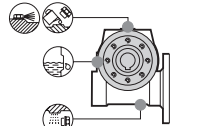
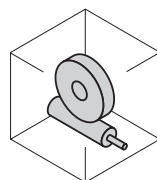

V5

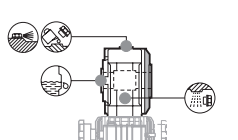
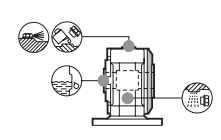
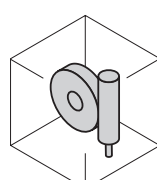

V6

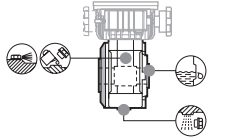
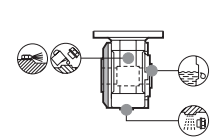
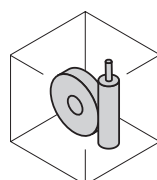

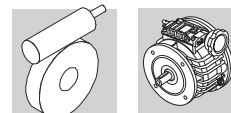

(F09)

## VF 130 F ... VF 250 F

	P (IEC)	V	P (IEC)	V
<b>B3</b>				
<b>B6</b>				
<b>B7</b>				
<b>B8</b>				
<b>V5</b>				
<b>V6</b>				

### Lubrificazione variatori

#### V, VD

La lubrificazione dei variatori V e VD avviene per sbattimento dell'olio. Prima della messa in funzione dei variatori accertarsi della presenza di olio al loro interno assicurandosi che esso compaia nella spia di livello.

#### VD

Tutti i variatori con differenziale VD completi di motore vengono forniti con carico di olio. Tutti i variatori con differenziale VD in configurazione P... (IEC), vengono forniti privi di olio. In questo caso l'utente dovrà provvedere al riempimento immettendo le quantità di olio indicate nelle tabelle (F10 - F11) e dovrà utilizzare motori elettrici con l'anello di tenuta lato albero e la flangia di accoppiamento al variatore a tenuta di olio.

### Lubrication of variators

#### V and VD

Variators V and VD are splash-lubricated. Before putting the variator into operation make sure there is oil inside up to the sight glass level.

#### VD

Motorized VD variators featuring the differential unit are factory filled with oil unlike VD variators with the IEC motor adapter (P...) which are supplied dry and must be filled with oil prior to be put into operation.

Proper oil quantity is shown in table (F10 - F11) and relates to actual mounting position.

### Schmierung der Verstellgetriebe

#### V, VD

Die Schmierung der Verstellgetriebe V und VD erfolgt durch Tauchschmierung im Ölbad. Vor der Inbetriebnahme der Verstellgetriebe muß geprüft werden, ob sie bis zur Ölstandskontrolle mit Öl gefüllt sind.

#### VD

Alle Verstellgetriebe mit Differential VD und Motor, sind bei Lieferung mit Öl gefüllt. Alle Verstellgetriebe mit Differential V-D für den Anbau eines IEC-Motors werden ohne Öl geliefert. Wenn der Kunde die Getrieb selbst mit Öl füllt, müssen die in Tabelle (F10 - F11) angegebenen Ölmenngen verwendet werden. Die zu verwendenden Motoren müssen einen Dichtring auf der Seite der Welle haben und der Flansch zur Kopplung an das Verstellgetriebe muß öldicht sein.

### Lubrification variateurs

#### V, VD

La lubrification des variateurs V et VD s'effectue par barbotage de l'huile. Avant la mise en service des variateurs/motovariateurs, vérifier la présence d'huile à l'intérieur en contrôlant que celle-ci apparaisse dans le témoin de niveau.

#### VD

Tous les variateurs avec différentiel VD avec moteur sont fournis avec le plein d'huile. Tous les variateurs avec différentiel VD en configuration P... (IEC) sont fournis sans huile. Dans ce cas, l'utilisateur doit effectuer le remplissage en versant la quantité d'huile indiquée dans le tableau (F10 - F11) et doit utiliser des moteurs électriques avec bague d'étanchéité côté arbre et bride d'accouplement au variateur étanche à l'huile.

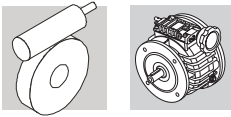

Benchè i variatori siano abbinabili a qualsiasi motore normalizzato IEC, **BONFIGLIOLI** raccomanda che siano utilizzati solo motori originali, provvisti di anelli di tenuta per l'olio.

*Although speed variators can match any IEC motors, **BONFIGLIOLI** recommends the use of genuine motors only, complete with shaft oil seals.*

Es wird empfohlen, die Verstellgetriebe mit Differential mit öldichten **BONFIGLIOLI** RIDUTTORI Motoren zu kaufen.

*Dans tous les cas, il est conseillé d'acquérir des variateurs avec différentiel avec moteurs avec étanchéité à l'huile **BONFIGLIOLI** RIDUTTORI.*

I variatori V 0.25 e V 0.5 vengono forniti completi di olio lubrificante "long life" sintetico **SHELL SPIRAX S4 ATF HDX**. Eventuali sostituzioni o rabbocchi dovranno essere effettuati utilizzando lo stesso tipo di prodotto.

*Variator units V 0.25 and V 0.5 are factory filled with "long life" synthetic oil **SHELL SPIRAX S4 ATF HDX**. Use same oil when topping up or refilling.*

Die Verstellgetriebe V 0.25 und V 0.5 werden mit Schmieröl **SHELL SPIRAX S4 ATF HDX** geliefert. Eventuelle Ölwechsel oder Nachfüllungen müssen unter Anwendung des gleichen Produkttyps erfolgen.

*Les variateurs V 0.25 et V 0.5 sont fournis avec de l'huile lubrifiante "long life" **SHELL SPIRAX S4 ATF HDX**. Utiliser le même type d'huile pour les éventuels vidanges ou remplissages.*

I variatori V 1...V 10 vengono forniti completi di olio lubrificante minerale **SHELL SPIRAX S2 ATF AX**. Eventuali sostituzioni o rabbocchi potranno essere effettuati utilizzando lubrificanti compatibili.

*Variator units V 1 through V 10 are factory filled with mineral oil **SHELL SPIRAX S2 ATF AX**. Use same type of oil when topping up or refilling.*

Die Verstellgetriebe V 1...V 10 werden mit dem Schmieröl **SHELL SPIRAX S2 ATF AX** geliefert. Ein eventueller Wechsel oder ein etwaiges Auffüllen sollte unter Verwendung der Schmiermittel erfolgen.

*Les variateurs V 1...V 10 sont fournis avec de l'huile lubrifiante **SHELL SPIRAX S2 ATF AX**. Utiliser le même type d'huiles pour les éventuels vidanges ou remplissages.*

Riduzione **R** lubrificata "a vita" con grasso **SHELL GADUS S5 V142W 00**.

*Helical reduction **R** is grease lubed "for life" with **SHELL GADUS S5 V142W 00**.*

Die Vorstufe **R** ist mit Fett Typ **SHELL GADUS S5 V142W 00** gefüllt.

*Réduction **R** avec lubrification permanente au moyen de graisse **SHELL GADUS S5 V142W 00**.*

Tutti i variatori sono forniti con carica di lubrificante, ad eccezione dei tipi **VD\_P(IEC)**.

*All speed variators are factory filled with lubricant, with the only exception of units type **VD\_P(IEC)**.*

Alle Verstellgetriebe sind ab Werk mit Öl gefüllt, außer dem Typ **VD\_P(IEC)**.

*Tous les variateurs sont fournis avec le lubrifiant, à l'exception des modèles **VD\_P (IEC)**.*

Il tappo di sfiato, fornito a corredo, va posizionato come indicato nelle tabelle (F10 - F11).

*The breather plug, supplied along with every unit, shall be located as per the schemes (F10 - F11).*

Der Entlüftungsstopfen, der jedem Getriebe beiligt, muss entsprechend der obige Skizze montiert werden.

*Le bouchon d'évent, fourni avec chaque variateur, doit être positionné comme indiqué dans les schémas (F10 - F11).*



Non mescolare oli di natura diversa.



*Do not mix synthetic oil with mineral oil.*



Auf keinen Fall darf synthetisches Öl mit mineralischem gemischt werden!



*Ne pas mélanger huiles de nature différente.*

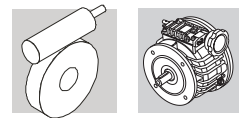

Collocazione dei tappi di carico, scarico e livello olio.

Positions of oil fill, level and drain plugs.

Anordnung des Einfüll-, Ölstands- und Ölablaßschrauben.

Position des bouchons de remplissage, niveau et vidange d'huile.

(F10)

V 0.25 - V 0.5

V 1 - V 2

B3		V 0.25 F	0.14		
		V 0.5 F	0.18		
		V 0.25 U / VR 0.25_	0.12		
		V 0.5 U_7 VR 0.5_	0.15		
		VD 0.5 U_ / VRD 0.5	0.30		
Oil SPIRAX S4 ATF HDX (for life)					
B6		V 1 F	0.30		
		V 2 F	0.40		
		V 1 U_ / VR 1_	0.25		
		V 2 U_ / VR 2_	0.32		
		VD 1 U_ / VRD 1	0.35		
		VD 2 U_ / VRD 2	0.46		
Oil SPIRAX S2 ATF AX (2000-3000 hrs.)					
B7		V 0.25 F	0.14		
		V 0.5 F	0.18		
		V 0.25 U / VR 0.25_	0.12		
		V 0.5 U_7 VR 0.5_	0.15		
		VD 0.5 U_ / VRD 0.5	0.30		
Oil SPIRAX S4 ATF HDX (for life)					
B8		V 1 F	0.30		
		V 2 F	0.40		
		V 1 U_ / VR 1_	0.25		
		V 2 U_ / VR 2_	0.32		
		VD 1 U_ / VRD 1	0.35		
		VD 2 U_ / VRD 2	0.46		
Oil SPIRAX S2 ATF AX (2000-3000 hrs.)					
V5		V 0.25 F	0.28		
		V 0.5 F	0.30		
		V 0.25 U / VR 0.25_	0.22		
		V 0.5 U_7 VR 0.5_	0.27		
		VD 0.5 U_ / VRD 0.5	0.70		
Oil SPIRAX S4 ATF HDX (for life)					
V6		V 1 F	0.58		
		V 2 F	0.78		
		V 1 U_ / VR 1_	0.40		
		V 2 U_ / VR 2_	0.54		
		VD 1 U_ / VRD 1	1.00		
		VD 2 U_ / VRD 2	1.5		
Oil SPIRAX S2 ATF AX (2000-3000 hrs.)					
V5		V 1 F	0.30		
		V 2 F	0.40		
		V 1 U_ / VR 1_	0.25		
		V 2 U_ / VR 2_	0.32		
		VD 1 U_ / VRD 1	0.50		
		VD 2 U_ / VRD 2	0.70		
Oil SPIRAX S2 ATF AX (2000-3000 hrs.)					
V6		V 0.25 F	0.14		
		V 0.5 F	0.18		
		V 0.25 U / VR 0.25_	0.12		
		V 0.5 U_7 VR 0.5_	0.15		
		VD 0.5 U_ / VRD 0.5	0.40		
Oil SPIRAX S4 ATF HDX (for life)					
V6		V 1 F	0.30		
		V 2 F	0.40		
		V 1 U_ / VR 1_	0.25		
		V 2 U_ / VR 2_	0.32		
		VD 1 U_ / VRD 1	0.50		
		VD 2 U_ / VRD 2	0.70		
Oil SPIRAX S2 ATF AX (2000-3000 hrs.)					



Tappo di sfogo  
Breather plug  
Entlüftungsstopfen  
Bouchon d'évent



Tappo di carico  
Filler plug  
Einfüllstopfen  
Bouchon de remplissage



Tappo di scarico  
Drain plug  
Ablassstopfen  
Bouchon de vidange



Tappo di livello  
Level plug  
Ölstandsstopfen  
Bouchon de niveau



Raccordo orientabile  
90° elbow  
90° Winkel  
Raccord coudé

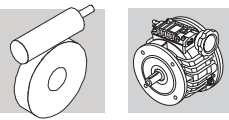

Collocazione dei tappi di carico, scarico e livello olio.

Positions of oil fill, level and drain plugs.

Anordnung des Einfüll-, Ölstands- und Ölablaßschrauben.

Position des bouchons de remplissage, niveau et vidange d'huile.

(F11)

### V 3 - V 5.5

### V 10

B3

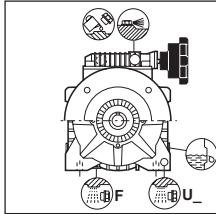

V 3 F - V 5.5 F_	0.70	
V 3 U / VR 3 V 5.5 U / VR 5.5	1.0	
VD 3 F VD 5.5 F_	1.3	
VD 3 U / VRD 3 U VD 5.5 U / VRD 5.5 U_	1.6	
Oil SPIRAX S2 ATF AX (2000-3000 hrs.)		

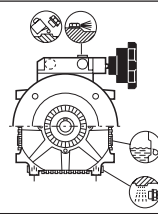

V 10 F V 10 U_ / VR 10	1.8	
VD 10 F VD 10 U_ / VRD 10 U_	2.0	
Oil SPIRAX S2 ATF AX (2000-3000 hrs.)		

B6

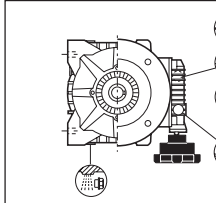

V 3 F - V 5.5 F_	0.90	
V 3 U / VR 3 V 5.5 U / VR 5.5	1.0	
VD 3 F VD 5.5 F_	1.3	
VD 3 U / VRD 3 U VD 5.5 U / VRD 5.5 U_	1.6	
Oil SPIRAX S2 ATF AX (2000-3000 hrs.)		

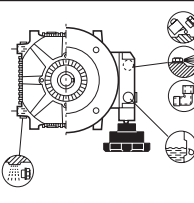

V 10 F V 10 U_ / VR 10	1.8	
VD 10 F VD 10 U_ / VRD 10 U_	2.0	
Oil SPIRAX S2 ATF AX (2000-3000 hrs.)		

B7

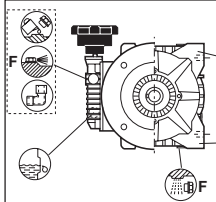

V 3 F - V 5.5 F_	0.90	
V 3 U / VR 3 V 5.5 U / VR 5.5	1.0	
VD 3 F VD 5.5 F_	1.3	
VD 3 U / VRD 3 U VD 5.5 U / VRD 5.5 U_	1.6	
Oil SPIRAX S2 ATF AX (2000-3000 hrs.)		

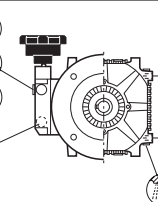

V 10 F V 10 U_ / VR 10	1.8	
VD 10 F VD 10 U_ / VRD 10 U_	2.0	
Oil SPIRAX S2 ATF AX (2000-3000 hrs.)		

B8

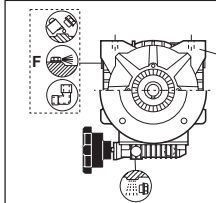

V 3 F - V 5.5 F_	1.0	
V 3 U / VR 3 V 5.5 U / VR 5.5	1.3	
VD 3 F VD 5.5 F_	1.6	
VD 3 U / VRD 3 U VD 5.5 U / VRD 5.5 U_	1.9	
Oil SPIRAX S2 ATF AX (2000-3000 hrs.)		

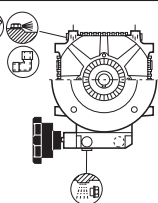

V 10 F V 10 U_ / VR 10	2.1	
VD 10 F VD 10 U_ / VRD 10 U_	2.1	
Oil SPIRAX S2 ATF AX (2000-3000 hrs.)		

V5

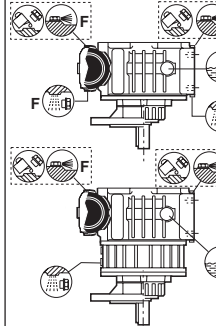

V 3 F - V 5.5 F_	2.1	
V 3 U / VR 3 V 5.5 U / VR 5.5	2.0	
Oil SPIRAX S2 ATF AX (2000-3000 hrs.)		
VD 3 F VD 5.5 F_	4.5	
VD 3 U / VRD 3 U VD 5.5 U / VRD 5.5 U_	4.8	
Oil SPIRAX S2 ATF AX (2000-3000 hrs.)		

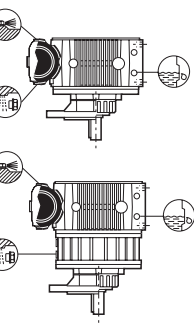

V 10 F V 10 U_ / VR 10	3.2	
Oil SPIRAX S2 ATF AX (2000-3000 hrs.)		
VD 10 F VD 10 U_ / VRD 10	8.5	
Oil SPIRAX S2 ATF AX (2000-3000 hrs.)		

V6

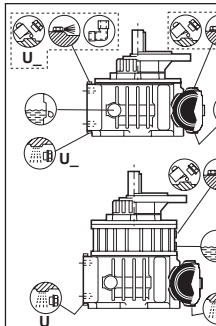

V 3 F - V 5.5 F_	1.0	
V 3 U / VR 3 V 5.5 U / VR 5.5	1.3	
Oil SPIRAX S2 ATF AX (2000-3000 hrs.)		
VD 3 F VD 5.5 F_	2.8	
VD 3 U / VRD 3 U VD 5.5 U / VRD 5.5 U_	3.0	
Oil SPIRAX S2 ATF AX (2000-3000 hrs.)		

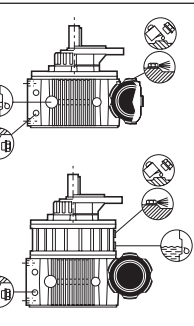

V 10 F V 10 U_ / VR 10	2.8	
Oil SPIRAX S2 ATF AX (2000-3000 hrs.)		
VD 10 F VD 10 U_ / VRD 10	7.0	
Oil SPIRAX S2 ATF AX (2000-3000 hrs.)		



Tappo di sfiao  
Breather plug  
Entlüftungsstopfen  
Bouchon d'évent



Tappo di carico  
Filler plug  
Einfüllstopfen  
Bouchon de remplissage



Tappo di scarico  
Drain plug  
Ablassstopfen  
Bouchon de vidange



Tappo di livello  
Level plug  
Ölstandsstopfen  
Bouchon de niveau



Raccordo orientabile  
90° elbow  
Bouchon de Winkel  
Raccord coudé

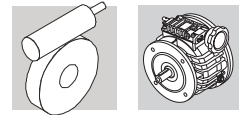

**23.7 - Posizioni di montaggio, orientamento morsetteria motore e comando variatore**

Le tabelle (F13...F30) evidenziano le posizioni che può assumere il variatore rispetto alla posizione di montaggio del riduttore.

In fase di ordine è necessario specificare oltre alla posizione di montaggio del riduttore anche la posizione del variatore, l'orientamento della morsetteria (W, N, E, S) e del comando (1, 2) scegliendo fra le alternative illustrate nelle tabelle.

La tabella (F12) facilita l'interpretazione delle varie posizioni di montaggio riportate.

**23.7 - Mounting position, motor terminal box angular position and variator control**

Tables (F13...F30) show the mounting positions of the variator depending on reducer mounting position.

Reducer mounting position and variator arrangement must be specified on order, as well as terminal board arrangement (W, N, E, S) and control position (1, 2). Choose from the options shown in the tables.

Table (F12) provides examples of the various mounting positions for better understanding.

**23.7 - Einbautagen, lage des Motorklemmenkastens und position der Steuerung des Verstellgetriebe**

Die Tabellen (F13...F30) stellen die Positionen dar, die das Verstellgetriebe den Einbautagen des Getriebes gegenüber einnehmen kann.

In der Auftragsphase muß daher über die Montageposition des Getriebes hinaus, auch die Lage des Verstellgetriebes, die Ausrichtung der Klemmenleiste (W, N, E, S) und position der Steuerung angegeben werden, die unter den in der Tabelle angegebenen Möglichkeiten ausgewählt werden können.

Die Tabelle (F12) erleichtert die Auslegung der verschiedenen, dargestellten Einbautagen.

**23.7 - Positions de montage, orientation boîte a borne du moteur et dispositif de commande variateur**

Les tableaux (F13...F30) indiquent les positions possibles du variateur par rapport à la position de montage du réducteur. Au moment de la commande, il est nécessaire de préciser la position de montage du réducteur ainsi que la position du variateur, l'orientation de la boîte à bornes (W, N, E, S) et la position du dispositif de commande (1, 2), en choisissant parmi les alternatives indiquées dans les tableaux.

Le tableau (F12) facilite l'interprétation des différentes positions de montage indiquées.

(F12)

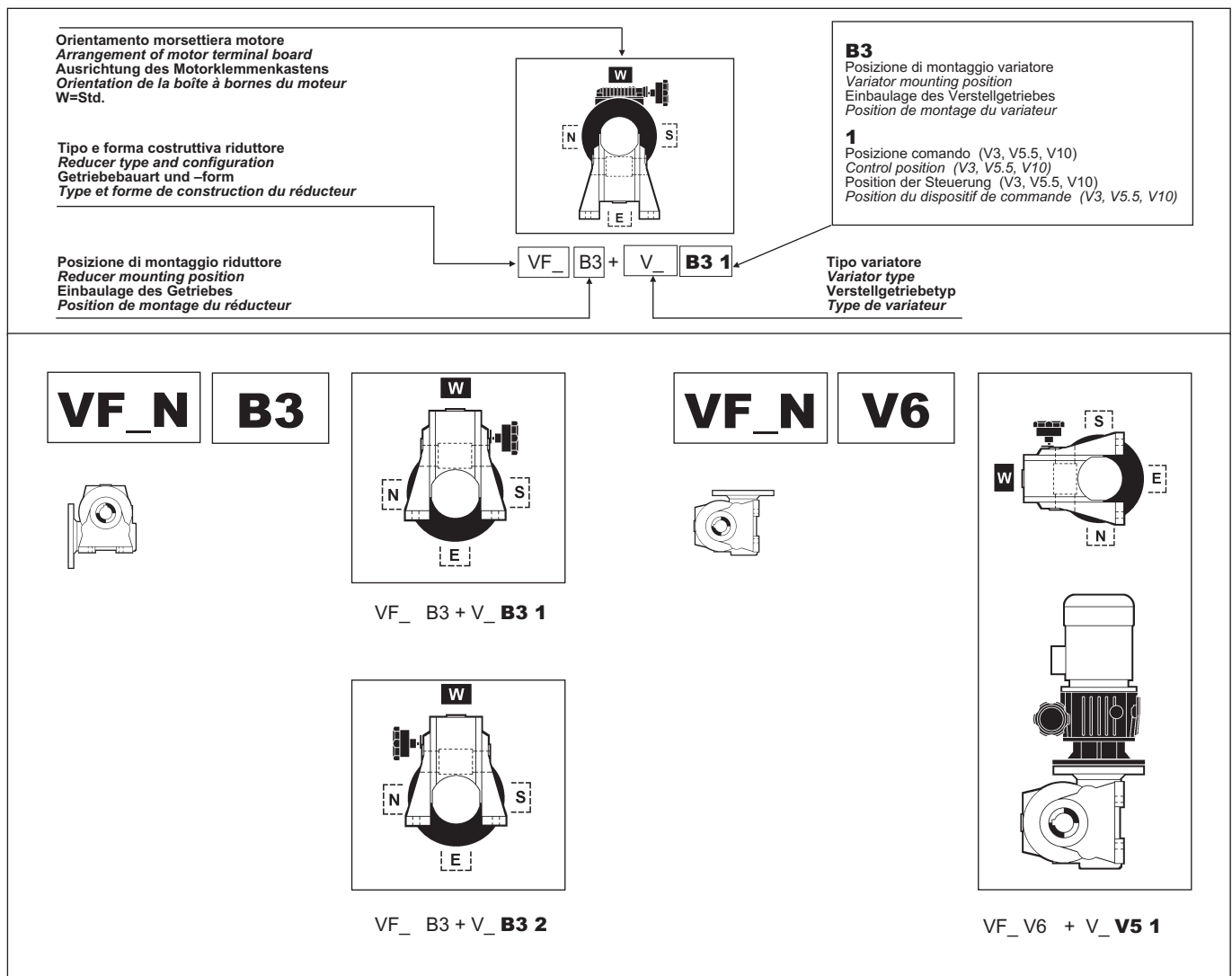

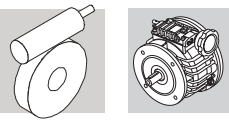

(F13)

**VF\_N**

**B3**

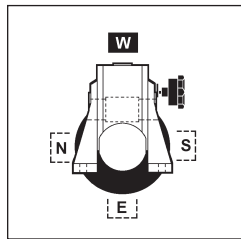
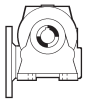

VF\_ B3 + V\_ **B3 1**

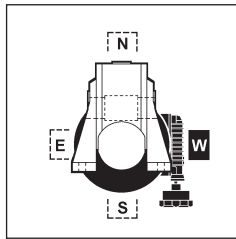

VF\_ B3 + V\_ **B6 1**

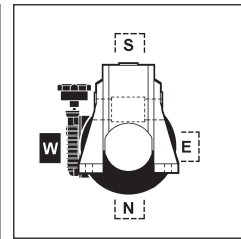

VF\_ B3 + V\_ **B7 1**

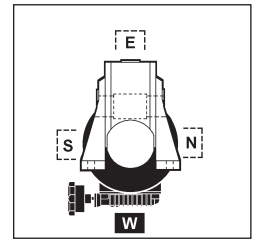

VF\_ B3 + V\_ **B8 1**

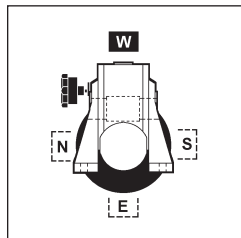

VF\_ B3 + V\_ **B3 2**

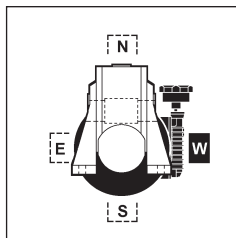

VF\_ B3 + V\_ **B6 2**

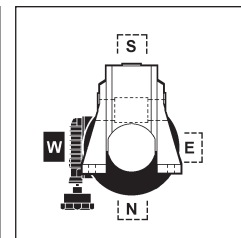

VF\_ B3 + V\_ **B7 2**

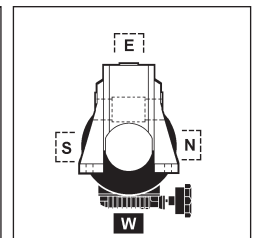

VF\_ B3 + V\_ **B8 2**

**VF\_N**

**B6**

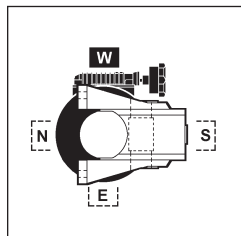

VF\_ B6 + V\_ **B3 1**

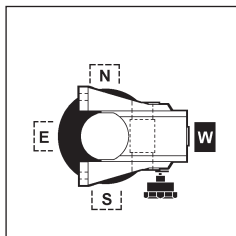

VF\_ B6 + V\_ **B6 1**

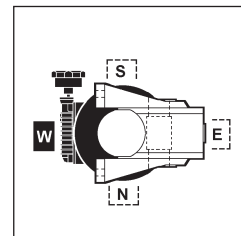

VF\_ B6 + V\_ **B7 1**

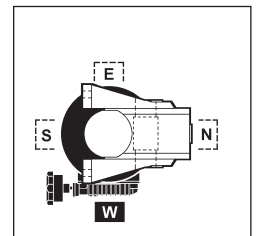

VF\_ B6 + V\_ **B8 1**

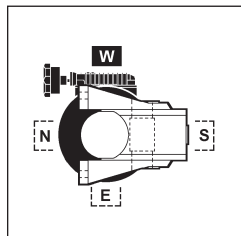

VF\_ B6 + V\_ **B3 2**

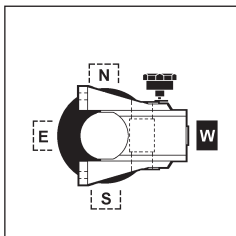

VF\_ B6 + V\_ **B6 2**

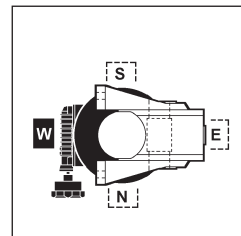

VF\_ B6 + V\_ **B7 2**

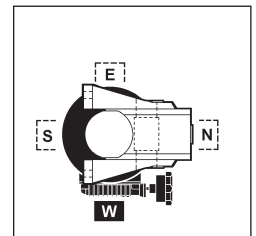

VF\_ B6 + V\_ **B8 2**

**VF\_N**

**B7**

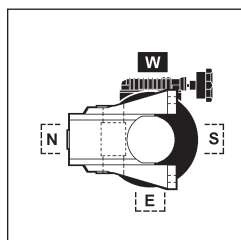

VF\_ B7 + V\_ **B3 1**

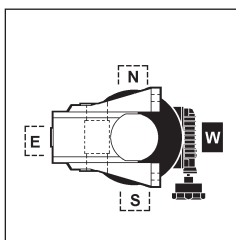

VF\_ B7 + V\_ **B6 1**

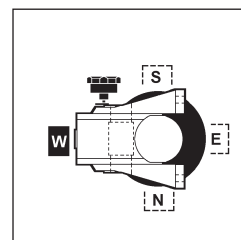

VF\_ B7 + V\_ **B7 1**

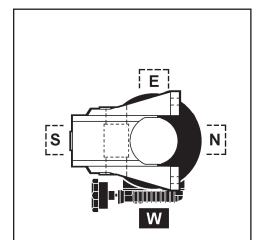

VF\_ B7 + V\_ **B8 1**

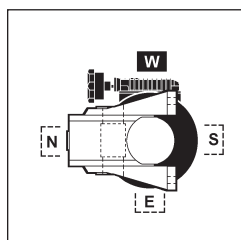

VF\_ B7 + V\_ **B3 2**

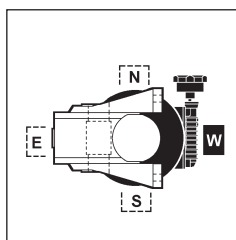

VF\_ B7 + V\_ **B6 2**

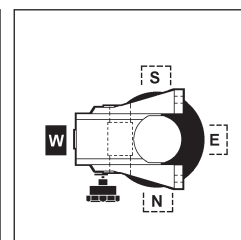

VF\_ B7 + V\_ **B7 2**

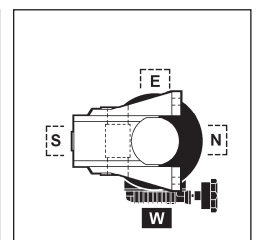

VF\_ B7 + V\_ **B8 2**



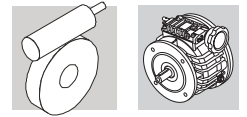

(F14)

<div data-bbox="129 241 284 315" style="border: 1px solid black; padding: 5px; font-weight: bold;">VF_N</div> <div data-bbox="316 241 443 315" style="border: 1px solid black; padding: 5px; font-weight: bold;">B8</div> <div data-bbox="151 362 236 461" style="margin-top: 20px;"> </div>					
	VF_ B8 + V_ B3 1	VF_ B8 + V_ B6 1	VF_ B8 + V_ B7 1	VF_ B8 + V_ B8 1	
	VF_ B8 + V_ B3 2	VF_ B8 + V_ B6 2	VF_ B8 + V_ B7 2	VF_ B8 + V_ B8 2	
	<div data-bbox="129 846 284 920" style="border: 1px solid black; padding: 5px; font-weight: bold;">VF_N</div> <div data-bbox="316 846 443 920" style="border: 1px solid black; padding: 5px; font-weight: bold;">V5</div> <div data-bbox="146 965 240 1043" style="margin-top: 20px;"> </div>				
		VF_ V5 + V_ V6 1	VF_ V5 + V_ V61 1	VF_ V5 + V_ V63 1	VF_ V5 + V_ V62 1
		VF_ V5 + V_ V6 2	VF_ V5 + V_ V61 2	VF_ V5 + V_ V63 2	VF_ V5 + V_ V62 2

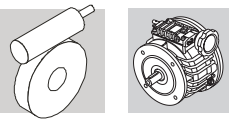

(F15)

**VF\_N**

**V6**

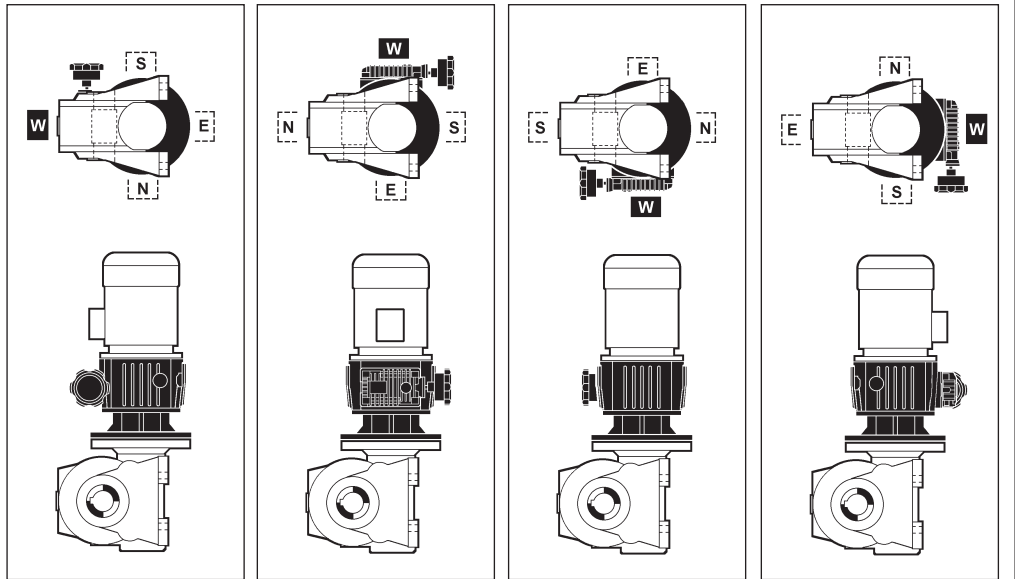

VF\_V6 + V\_V5 1

VF\_V6 + V\_V51 1

VF\_V6 + V\_V53 1

VF\_V6 + V\_V52 1

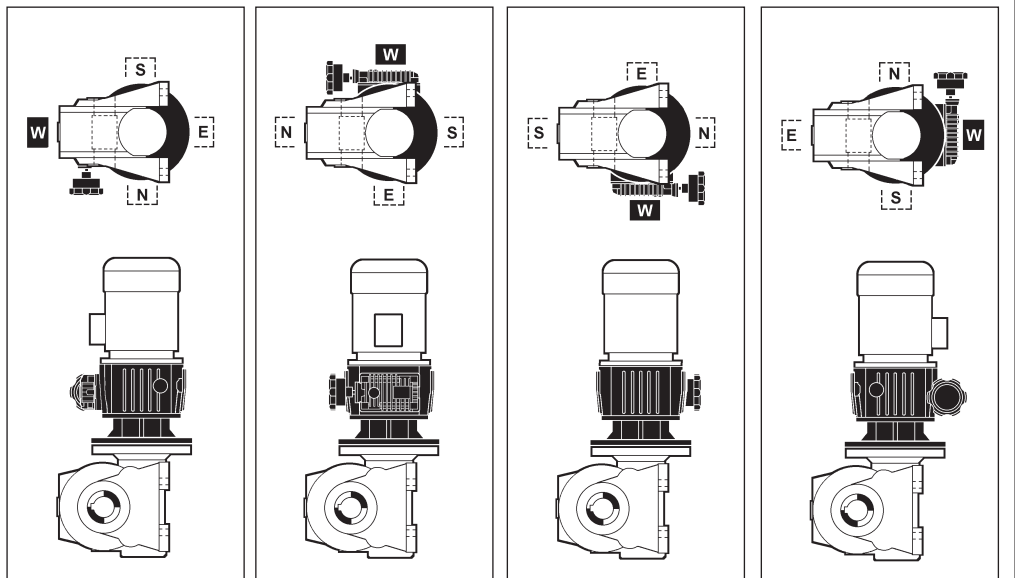

VF\_V6 + V\_V5 2

VF\_V6 + V\_V51 2

VF\_V6 + V\_V53 2

VF\_V6 + V\_V52 2

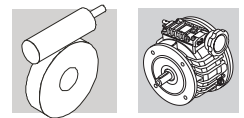

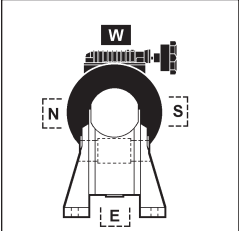
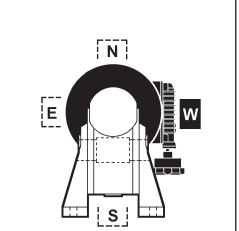
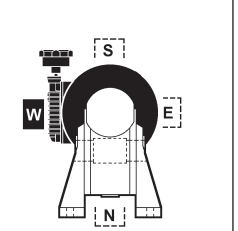
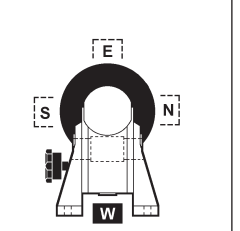
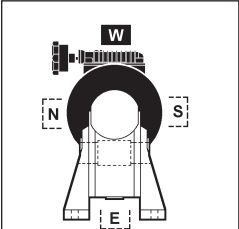
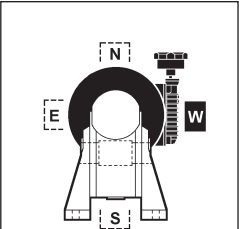
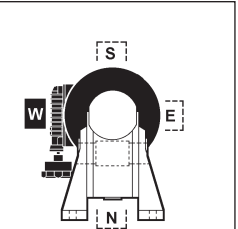
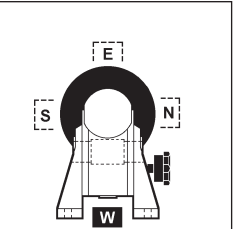
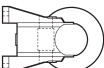
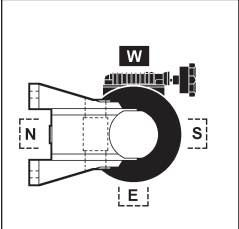
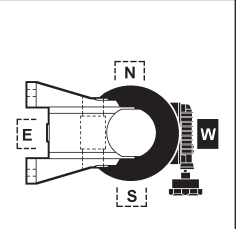
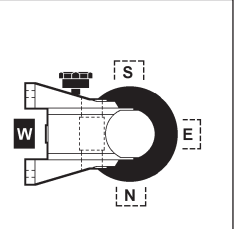
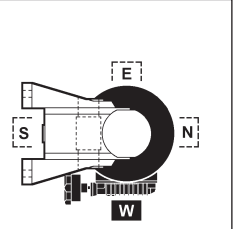
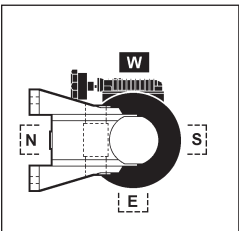
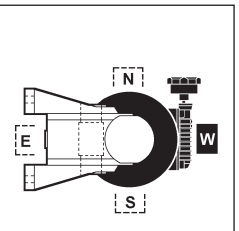
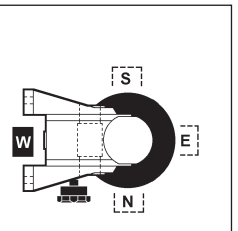
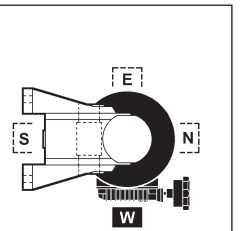
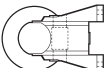
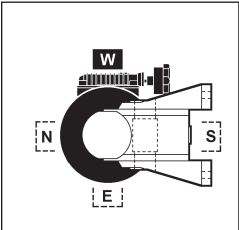
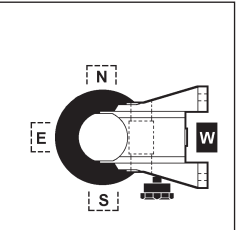
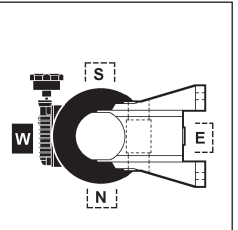
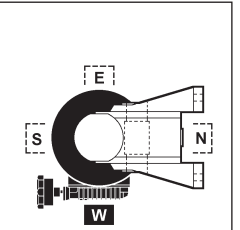
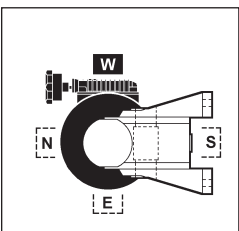
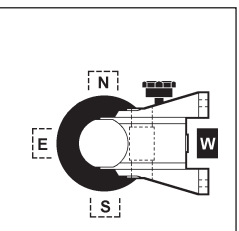
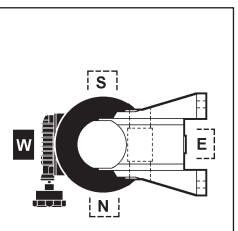
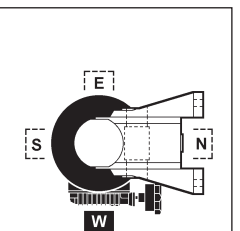

(F16)

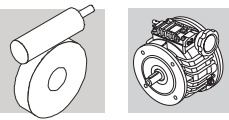
<b>VF_A</b> <b>VF_U</b> 	<b>B3</b>						
		VF_ B3 + V_ <b>B3 1</b>	VF_ B3 + V_ <b>B6 1</b>	VF_ B3 + V_ <b>B7 1</b>	VF_ B3 + V_ <b>B8 1</b>		
							
		VF_ B3 + V_ <b>B3 2</b>	VF_ B3 + V_ <b>B6 2</b>	VF_ B3 + V_ <b>B7 2</b>	VF_ B3 + V_ <b>B8 2</b>		
		<b>VF_A</b> <b>VF_U</b> 	<b>B6</b>				
				VF_ B6 + V_ <b>B3 1</b>	VF_ B6 + V_ <b>B6 1</b>	VF_ B6 + V_ <b>B7 1</b>	VF_ B6 + V_ <b>B8 1</b>
							
				VF_ B6 + V_ <b>B3 2</b>	VF_ B6 + V_ <b>B6 2</b>	VF_ B6 + V_ <b>B7 2</b>	VF_ B6 + V_ <b>B8 2</b>
<b>VF_A</b> <b>VF_U</b> 	<b>B7</b>						
				VF_ B7 + V_ <b>B3 1</b>	VF_ B7 + V_ <b>B6 1</b>	VF_ B7 + V_ <b>B7 1</b>	VF_ B7 + V_ <b>B8 1</b>
							
				VF_ B7 + V_ <b>B3 2</b>	VF_ B7 + V_ <b>B6 2</b>	VF_ B7 + V_ <b>B7 2</b>	VF_ B7 + V_ <b>B8 2</b>

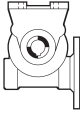
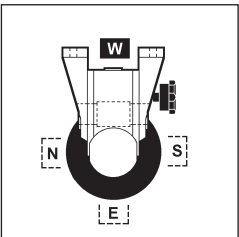
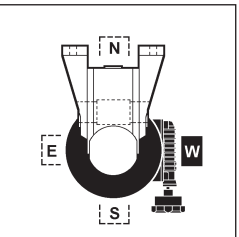
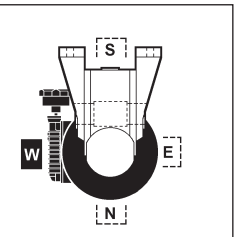
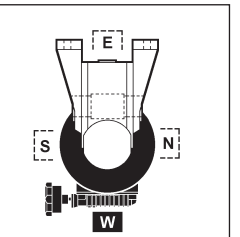
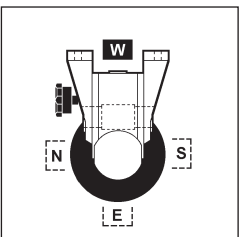
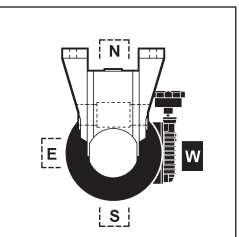
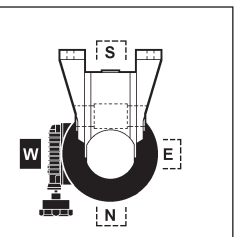
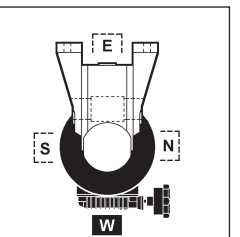

(F17)

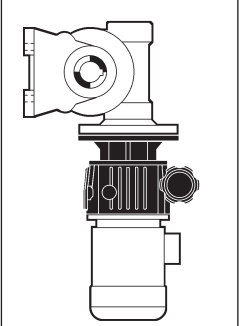
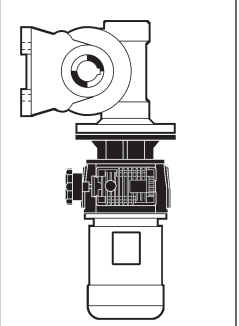
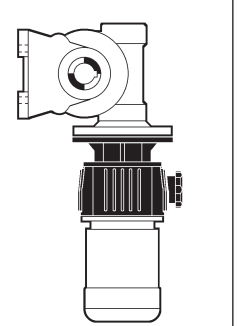
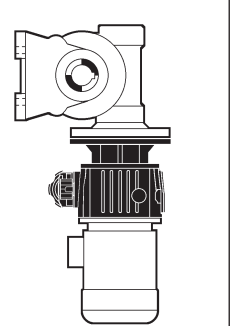
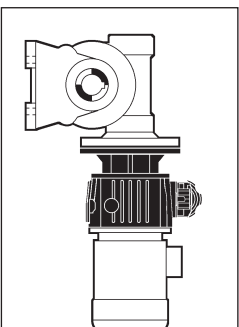
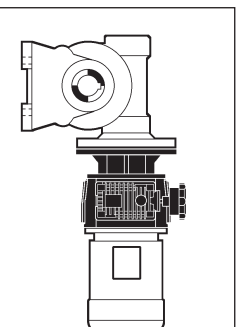
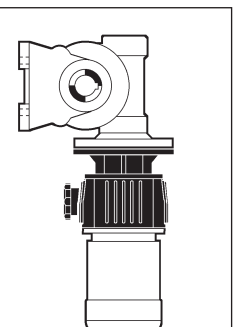
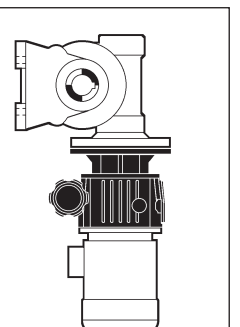
<b>VF_A</b> <b>VF_U</b> 	<b>B8</b>				
		<b>VF_ B8 + V_ B3 1</b>	<b>VF_ B8 + V_ B6 1</b>	<b>VF_ B8 + V_ B7 1</b>	<b>VF_ B8 + V_ B8 1</b>
					
		<b>VF_ B8 + V_ B3 2</b>	<b>VF_ B8 + V_ B6 2</b>	<b>VF_ B8 + V_ B7 2</b>	<b>VF_ B8 + V_ B8 2</b>
<b>VF_A</b> <b>VF_U</b> 	<b>V5</b>				
		<b>VF_ V5 + V_ V6 1</b>	<b>VF_ V5 + V_ V61 1</b>	<b>VF_ V5 + V_ V63 1</b>	<b>VF_ V5 + V_ V62 1</b>
					
		<b>VF_ V5 + V_ V6 2</b>	<b>VF_ V5 + V_ V61 2</b>	<b>VF_ V5 + V_ V63 2</b>	<b>VF_ V5 + V_ V62 2</b>

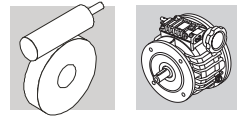

(F18)

**VF\_A**

**V6**

**VF\_U**

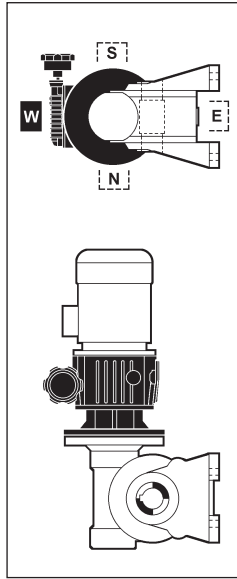
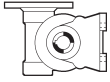

VF\_V6 + V\_V5 1

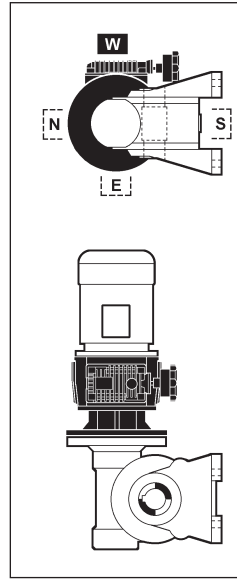

VF\_V6 + V\_V51 1

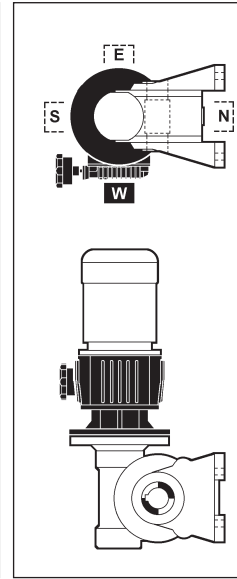

VF\_V6 + V\_V53 1

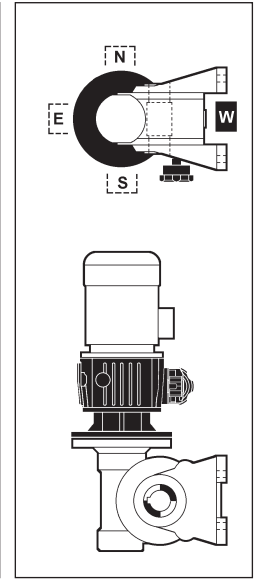

VF\_V6 + V\_V52 1

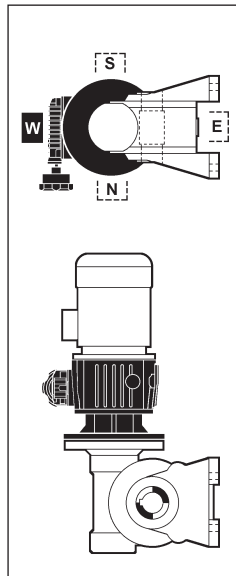

VF\_V6 + V\_V5 2

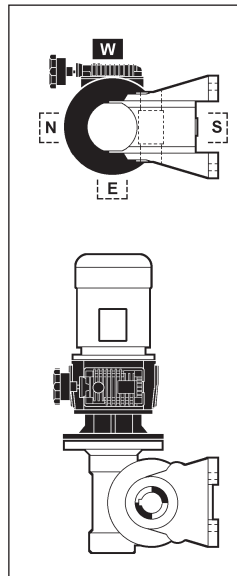

VF\_V6 + V\_V51 2

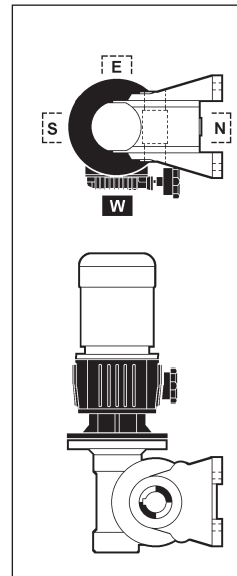

VF\_V6 + V\_V53 2

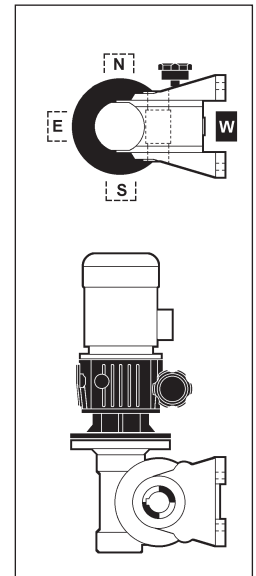

VF\_V6 + V\_V52 2

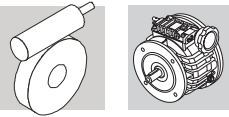

(F19)

**VF\_V**

**B3**

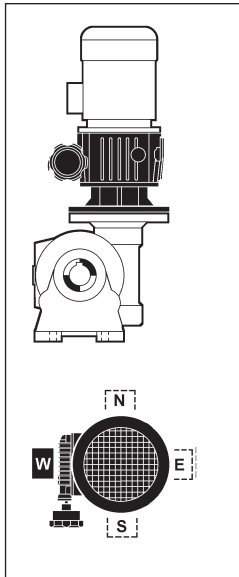

VF\_B3 + V\_V5 1

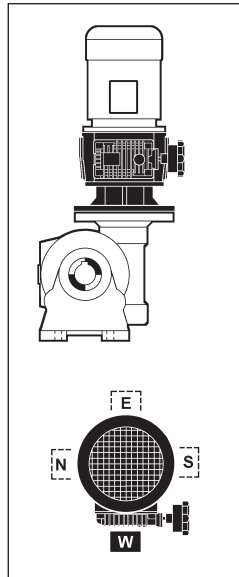

VF\_B3 + V\_V51 1

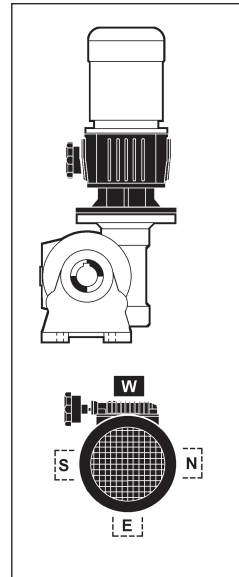

VF\_B3 + V\_V53 1

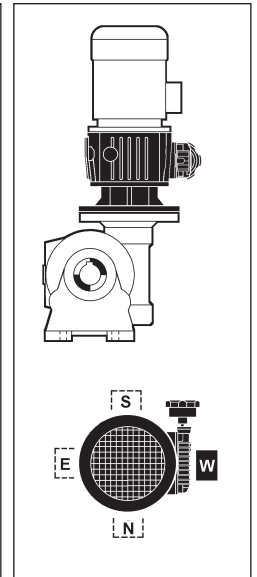

VF\_B3 + V\_V52 1

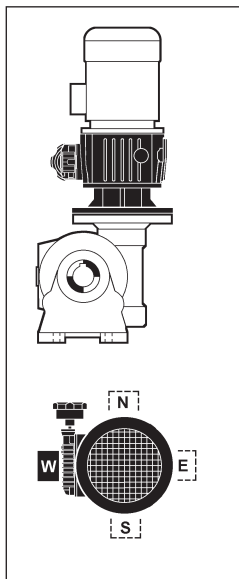

VF\_B3 + V\_V5 2

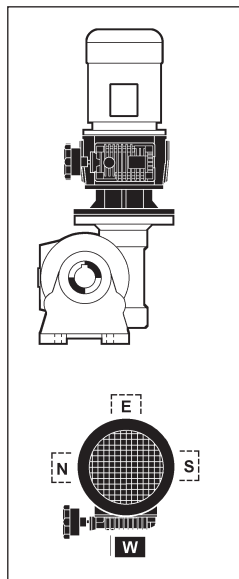

VF\_B3 + G\_V51 2

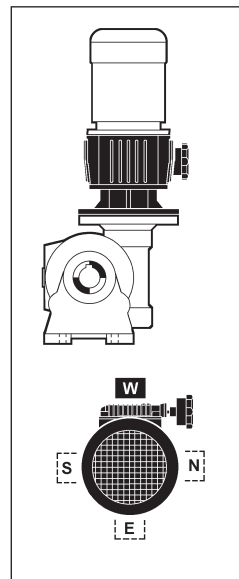

VF\_B3 + V\_V53 2

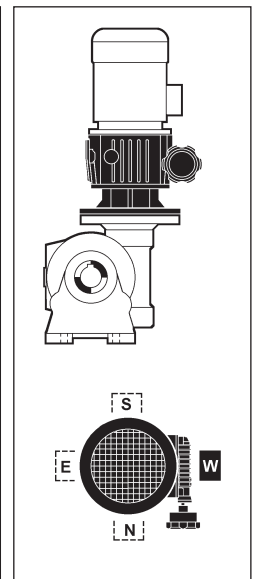

VF\_B3 + V\_V52 2

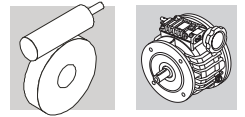

(F20)

**VF\_V**

**B8**

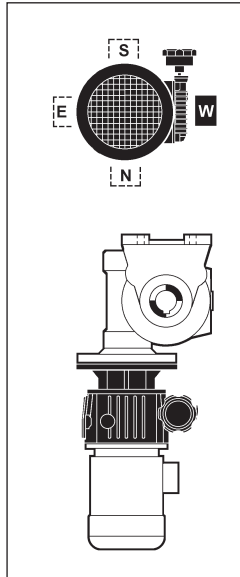

VF\_B8 + V\_V6 1

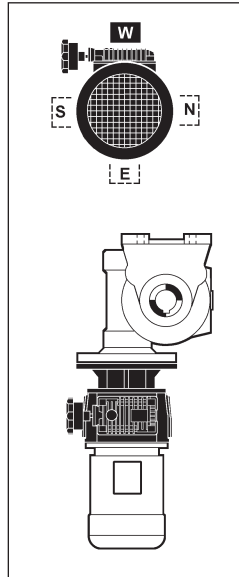

VF\_B8 + V\_V61 1

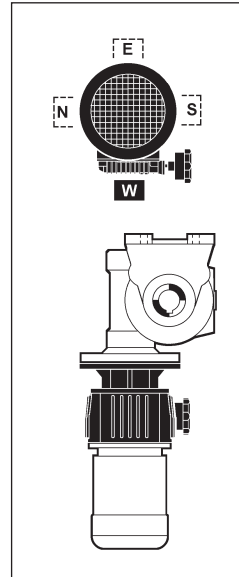

VF\_B8 + V\_V63 1

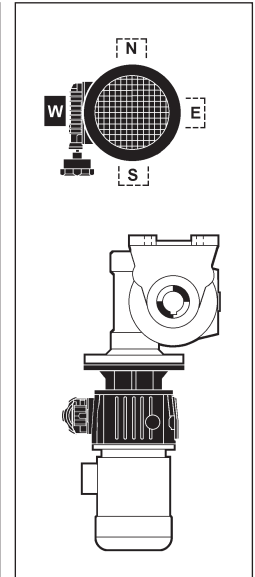

VF\_B8 + V\_V62 1

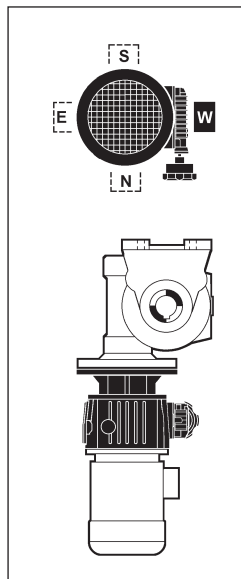

VF\_B8 + V\_V6 2

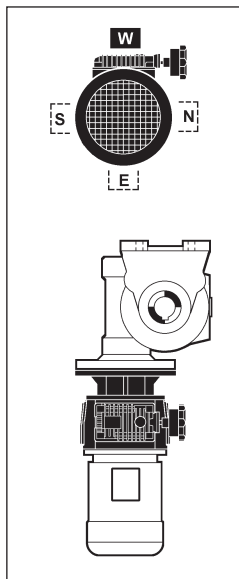

VF\_B8 + V\_V61 2

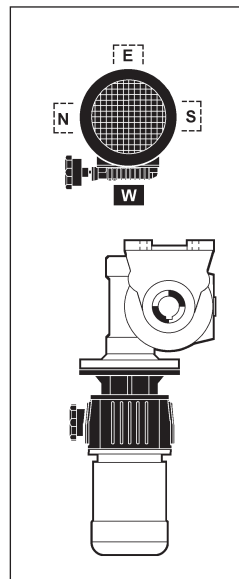

VF\_B8 + V\_V63 2

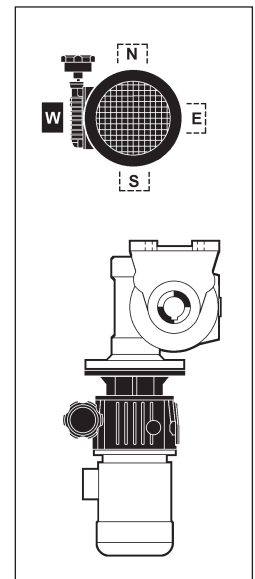

VF\_B8 + V\_V62 2

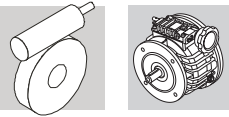

(F21)

**VF\_V**

**B6**

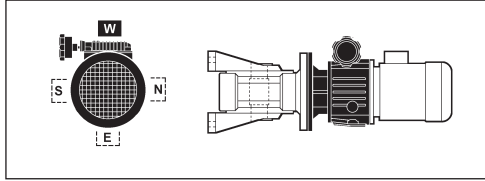

VF\_ B6 + V\_ **B3 1**

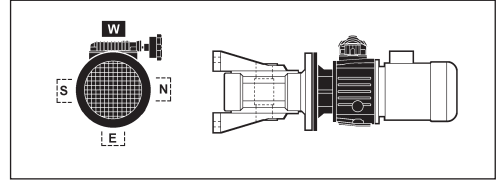

VF\_ B6 + V\_ **B3 2**

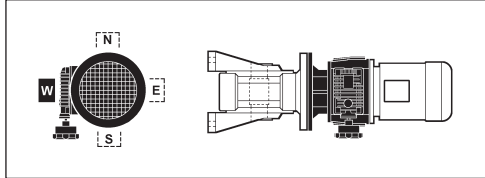

VF\_ B6 + V\_ **B6 1**

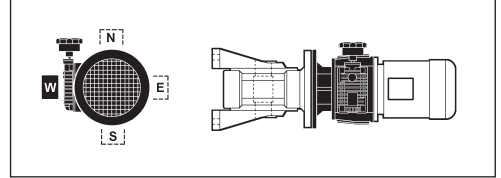

VF\_ B6 + V\_ **B6 2**

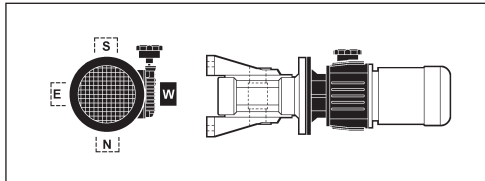

VF\_ B6 + V\_ **B7 1**

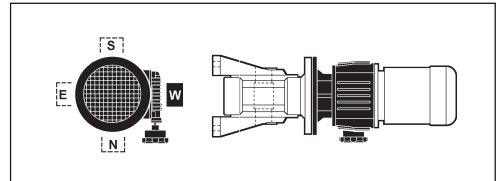

VF\_ B6 + V\_ **B7 2**

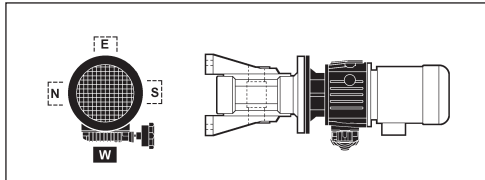

VF\_ B6 + V\_ **B8 1**

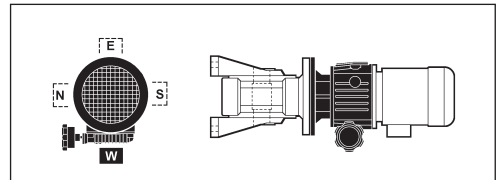

VF\_ B6 + V\_ **B8 2**

**VF\_V**

**B7**

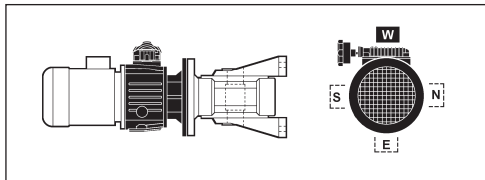

VF\_ B7 + V\_ **B3 1**

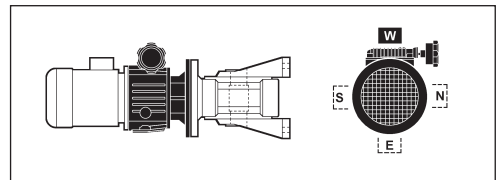

VF\_ B7 + V\_ **B3 2**

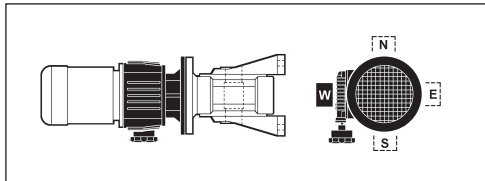

VF\_ B7 + V\_ **B6 1**

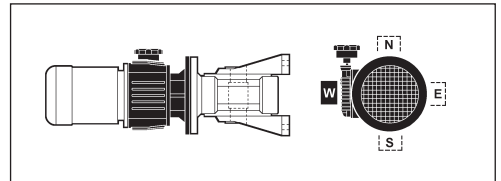

VF\_ B7 + V\_ **B6 2**

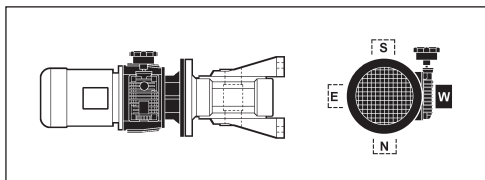

VF\_ B7 + V\_ **B7 1**

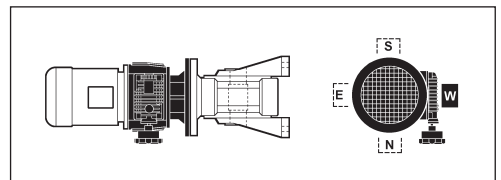

VF\_ B7 + V\_ **B7 2**

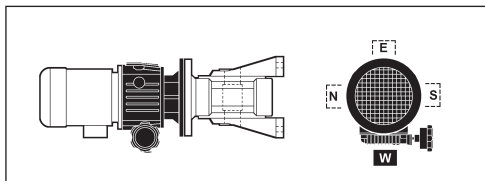

VF\_ B7 + V\_ **B8 1**

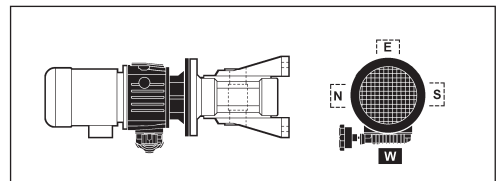

VF\_ B7 + V\_ **B8 2**



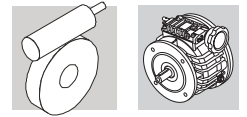

(F22)

**VF\_V**

**V5**

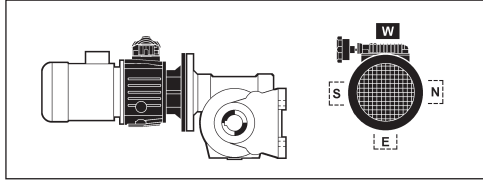
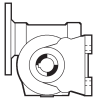

VF\_ V5 + V\_ **B3 1**

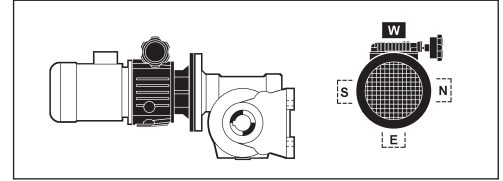

VF\_ V5 + V\_ **B3 2**

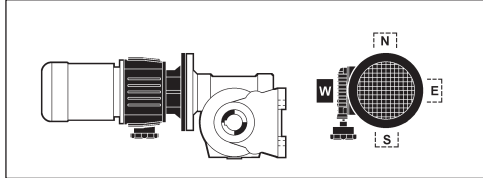

VF\_ V5 + V\_ **B6 1**

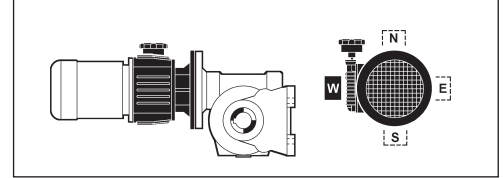

VF\_ V5 + V\_ **B6 2**

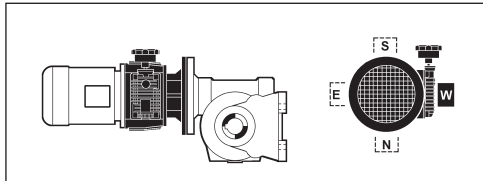

VF\_ V5 + V\_ **B7 1**

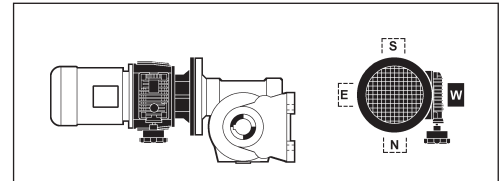

VF\_ V5 + V\_ **B7 2**

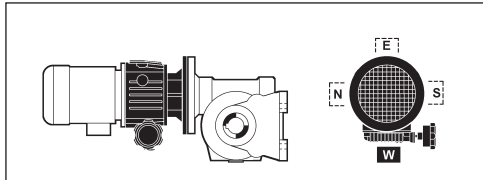

VF\_ V5 + V\_ **B8 1**

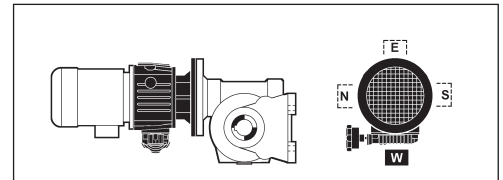

VF\_ V5 + V\_ **B8 2**

**VF\_V**

**V6**

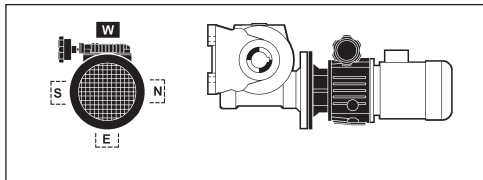
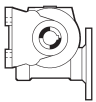

VF\_ V6 + V\_ **B3 1**

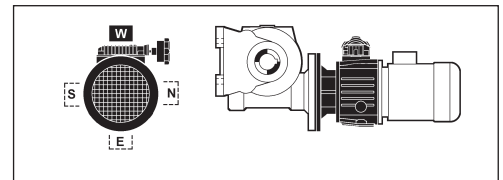

VF\_ V6 + V\_ **B3 2**

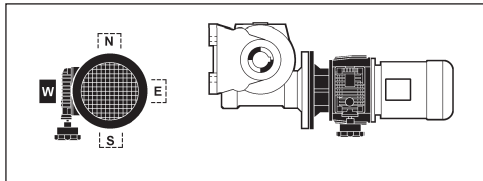

VF\_ V6 + V\_ **B6 1**

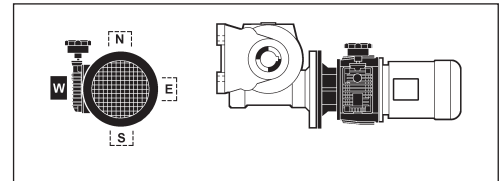

VF\_ V6 + V\_ **B6 2**

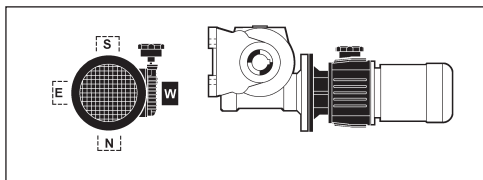

VF\_ V6 + V\_ **B7 1**

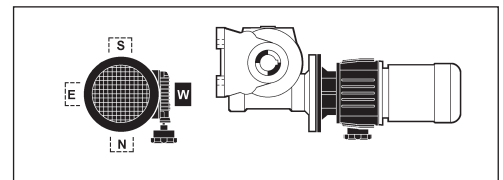

VF\_ V6 + V\_ **B7 2**

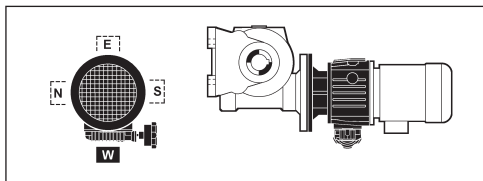

VF\_ V6 + V\_ **B8 1**

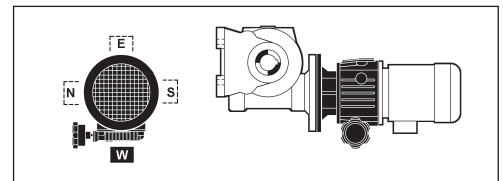

VF\_ V6 + V\_ **B8 2**

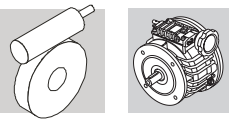

(F23)

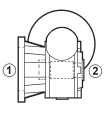
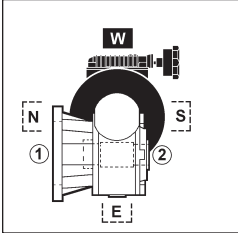
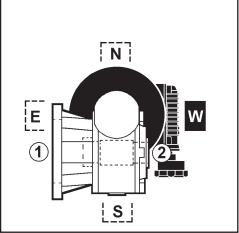
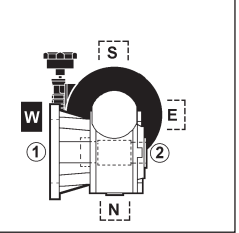
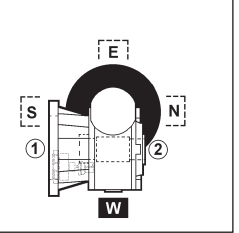
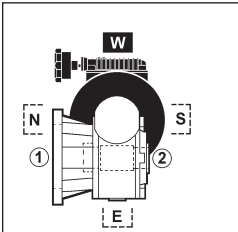
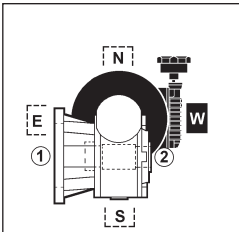
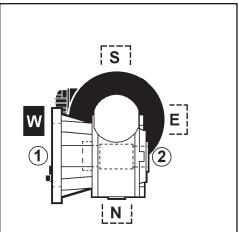
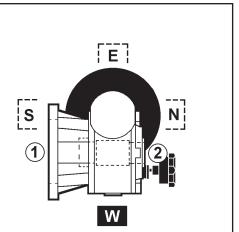
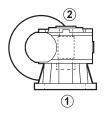
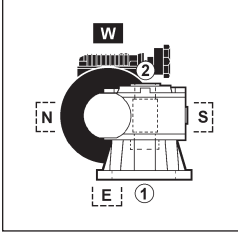
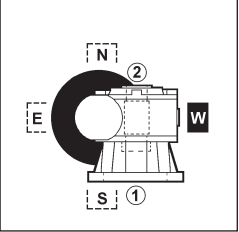
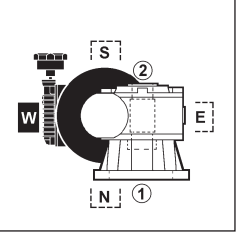
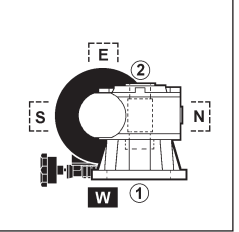
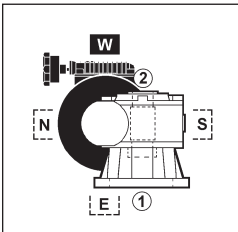
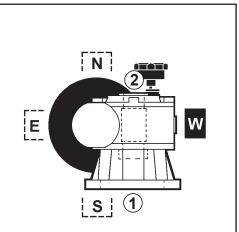
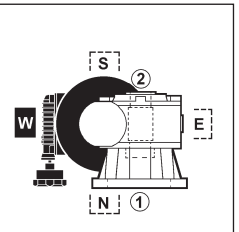
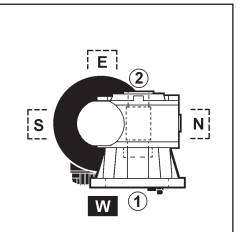
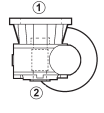
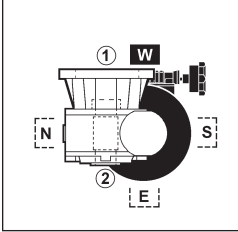
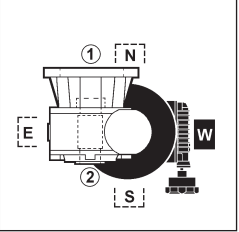
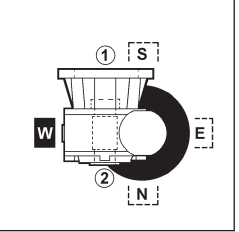
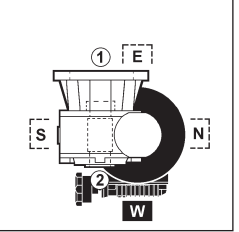
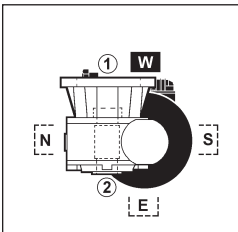
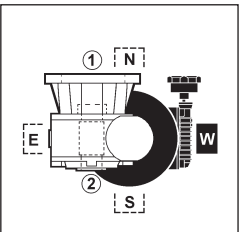
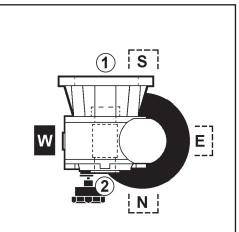
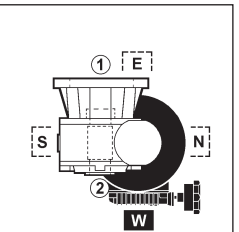
<div data-bbox="129 241 284 315" style="border: 1px solid black; padding: 5px; font-weight: bold;">VF_F</div> <div data-bbox="316 241 443 315" style="border: 1px solid black; padding: 5px; font-weight: bold;">B3</div> 					
	VF_ B3 + V_ <b>B3 1</b>	VF_ B3 + V_ <b>B6 1</b>	VF_ B3 + V_ <b>B7 1</b>	VF_ B3 + V_ <b>B8 1</b>	
					
	VF_ B3 + V_ <b>B3 2</b>	VF_ B3 + V_ <b>B6 2</b>	VF_ B3 + V_ <b>B7 2</b>	VF_ B3 + V_ <b>B8 2</b>	
	<div data-bbox="129 853 284 927" style="border: 1px solid black; padding: 5px; font-weight: bold;">VF_F</div> <div data-bbox="316 853 443 927" style="border: 1px solid black; padding: 5px; font-weight: bold;">B6</div> 				
		VF_ B6 + V_ <b>B3 1</b>	VF_ B6 + V_ <b>B6 1</b>	VF_ B6 + V_ <b>B7 1</b>	VF_ B6 + V_ <b>B8 1</b>
					
		VF_ B6 + V_ <b>B3 2</b>	VF_ B6 + V_ <b>B6 2</b>	VF_ B6 + V_ <b>B7 2</b>	VF_ B6 + V_ <b>B8 2</b>
<div data-bbox="129 1464 284 1538" style="border: 1px solid black; padding: 5px; font-weight: bold;">VF_F</div> <div data-bbox="316 1464 443 1538" style="border: 1px solid black; padding: 5px; font-weight: bold;">B7</div> 					
		VF_ B7 + V_ <b>B3 1</b>	VF_ B7 + V_ <b>B6 1</b>	VF_ B7 + V_ <b>B7 1</b>	VF_ B7 + V_ <b>B8 1</b>
					
		VF_ B7 + V_ <b>B3 2</b>	VF_ B7 + V_ <b>B6 2</b>	VF_ B7 + V_ <b>B7 2</b>	VF_ B7 + V_ <b>B8 2</b>

① ② Posizione flangia / Flange position / Flanschlage / Position bride

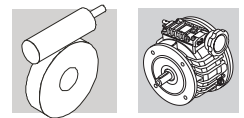

(F24)

**VF\_F**

**B8**

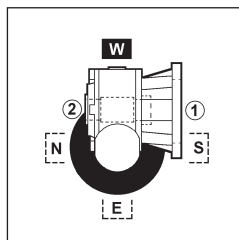
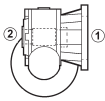

VF\_ B8 + V\_ B3 1

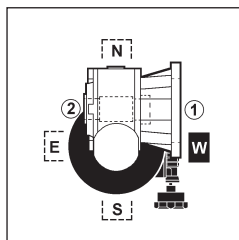

VF\_ B8 + V\_ B6 1

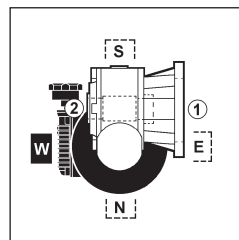

VF\_ B8 + V\_ B7 1

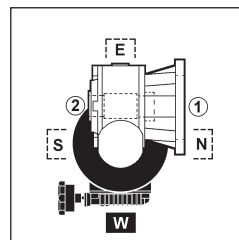

VF\_ B8 + V\_ B8 1

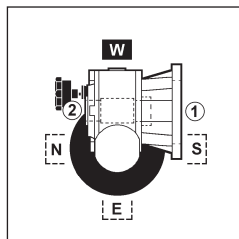

VF\_ B8 + V\_ B3 2

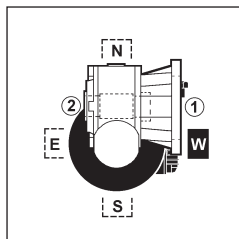

VF\_ B8 + V\_ B6 2

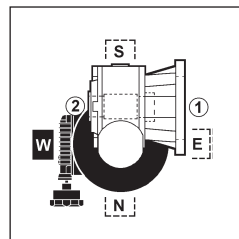

VF\_ B8 + V\_ B7 2

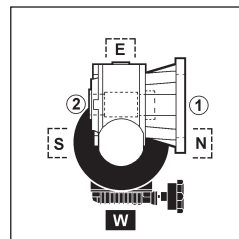

VF\_ B8 + V\_ B8 2

**VF\_F**

**V5**

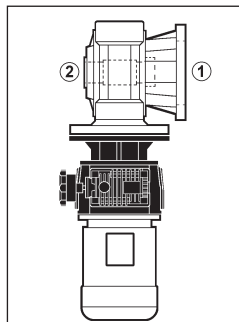
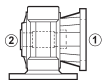

VF\_ V5 + V\_ V6 1

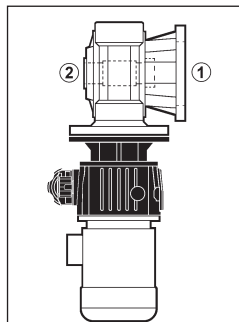

VF\_ V5 + V\_ V61 1

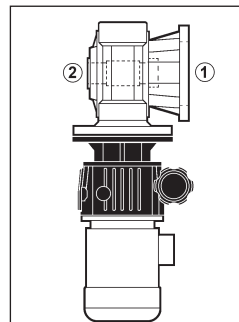

VF\_ V5 + V\_ V63 1

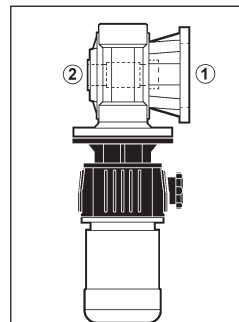

VF\_ V5 + V\_ V62 1

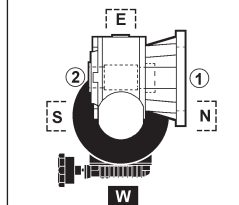

VF\_ V5 + V\_ V6 2

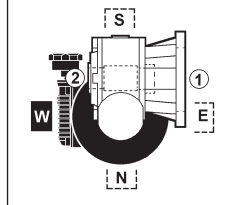

VF\_ V5 + V\_ V61 2

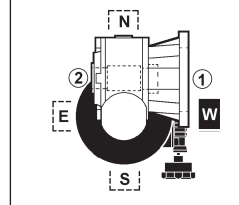

VF\_ V5 + V\_ V63 2

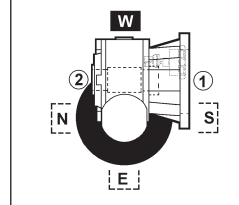

VF\_ V5 + V\_ V62 2

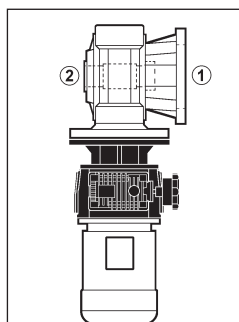

VF\_ V5 + V\_ V6 2

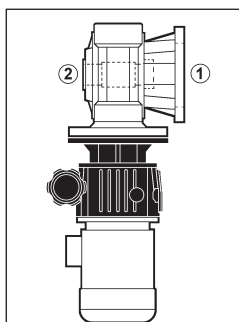

VF\_ V5 + V\_ V61 2

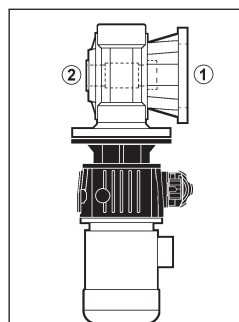

VF\_ V5 + V\_ V63 2

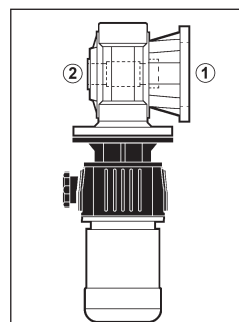

VF\_ V5 + V\_ V62 2

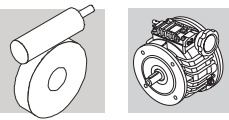

(F25)

**VF\_F**

**V6**

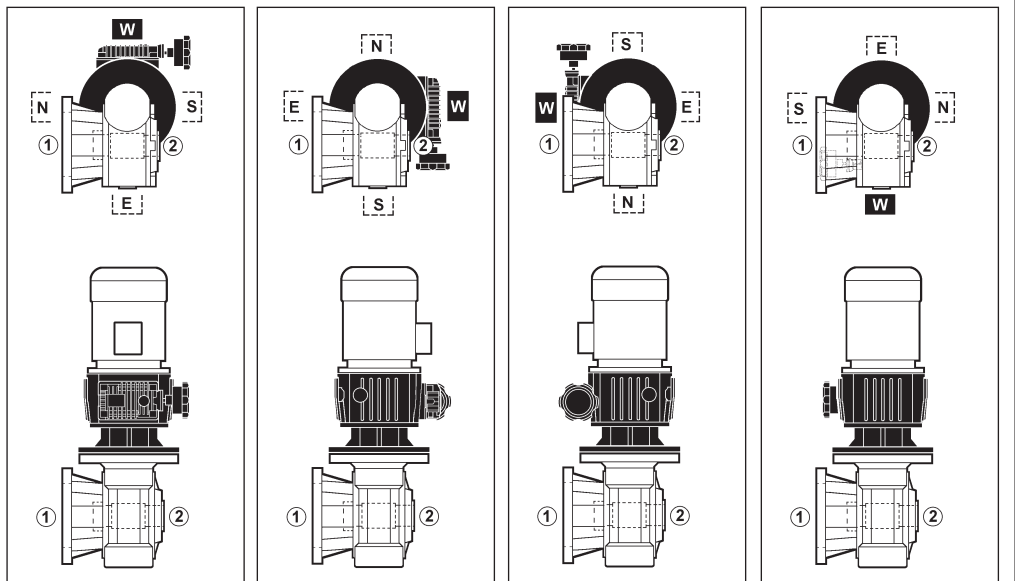
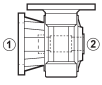

VF\_V6 + V\_V5 1

VF\_V6 + V\_V51 1

VF\_V6 + V\_V53 1

VF\_V6 + V\_V52 1

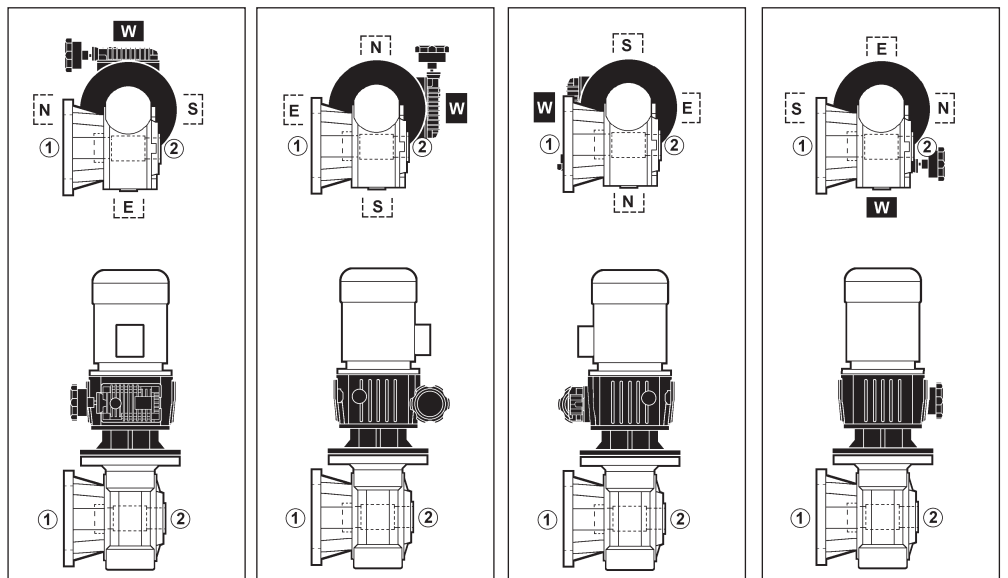

VF\_V6 + V\_V5 2

VF\_V6 + V\_V51 2

VF\_V6 + V\_V53 2

VF\_V6 + V\_V52 2

① ② Posizione flangia / Flange position / Flanschlage / Position bride

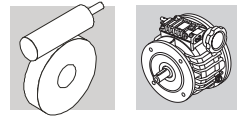

(F26)

**VF\_P**

**B3**

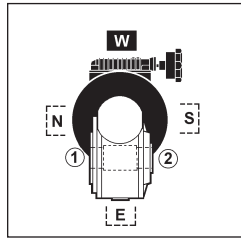

VF\_ B3 + V\_ **B3 1**

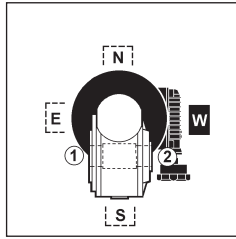

VF\_ B3 + V\_ **B6 1**

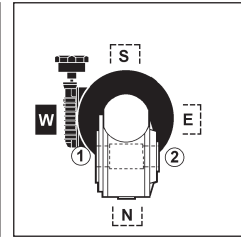

VF\_ B3 + V\_ **B7 1**

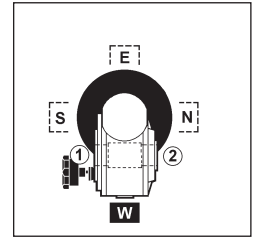

VF\_ B3 + V\_ **B8 1**

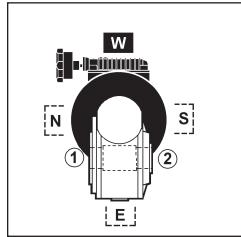

VF\_ B3 + V\_ **B3 2**

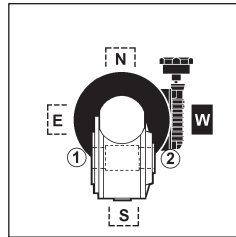

VF\_ B3 + V\_ **B6 2**

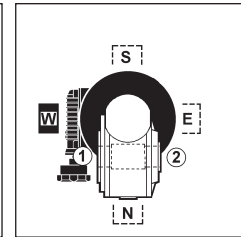

VF\_ B3 + V\_ **B7 2**

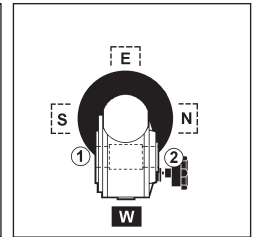

VF\_ B3 + V\_ **B8 2**

**VF\_P**

**B6**

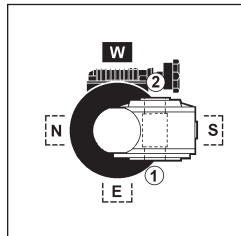

VF\_ B6 + V\_ **B3 1**

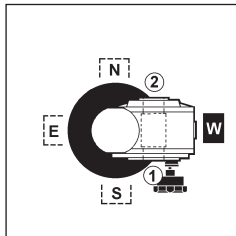

VF\_ B6 + V\_ **B6 1**

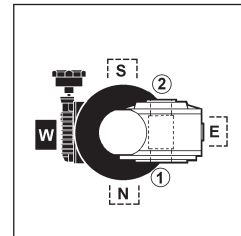

VF\_ B6 + V\_ **B7 1**

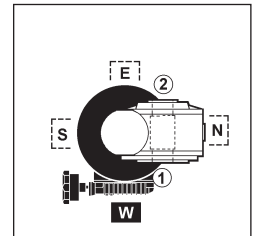

VF\_ B6 + V\_ **B8 1**

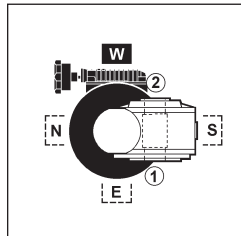

VF\_ B6 + V\_ **B3 2**

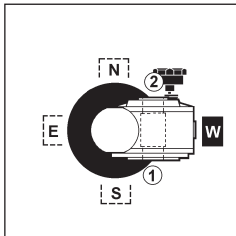

VF\_ B6 + V\_ **B6 2**

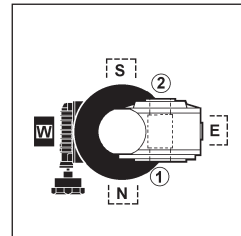

VF\_ B6 + V\_ **B7 2**

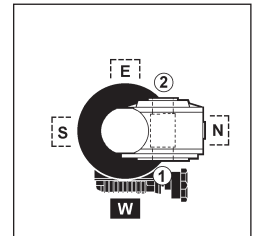

VF\_ B6 + V\_ **B8 2**

**VF\_P**

**B7**

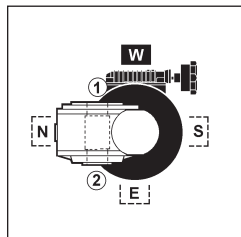

VF\_ B7 + V\_ **B3 1**

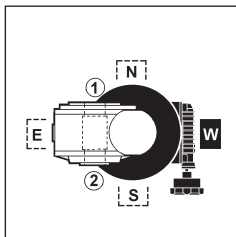

VF\_ B7 + V\_ **B6 1**

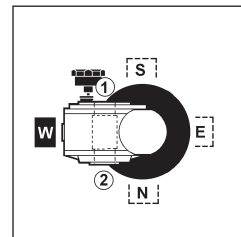

VF\_ B7 + V\_ **B7 1**

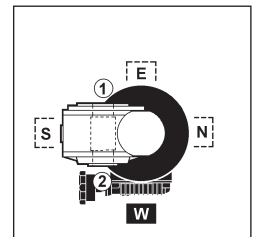

VF\_ B7 + V\_ **B8 1**

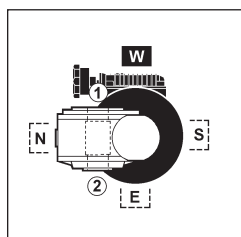

VF\_ B7 + V\_ **B3 2**

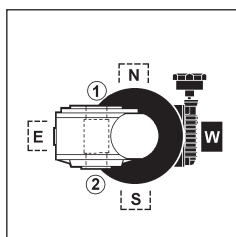

VF\_ B7 + V\_ **B6 2**

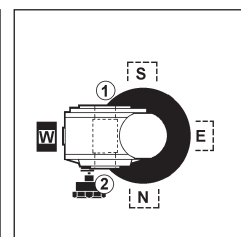

VF\_ B7 + V\_ **B7 2**

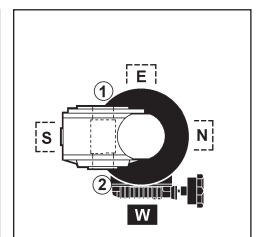

VF\_ B7 + V\_ **B8 2**

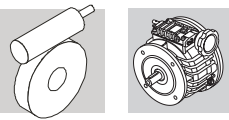

(F27)

**VF\_P**

**B8**

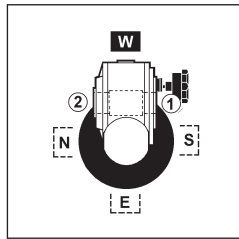

VF\_ B8 + V\_ B3 1

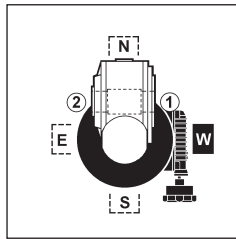

VF\_ B8 + V\_ B6 1

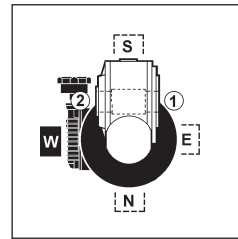

VF\_ B8 + V\_ B7 1

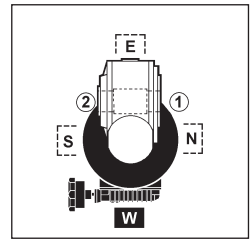

VF\_ B8 + V\_ B8 1

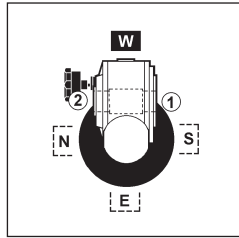

VF\_ B8 + V\_ B3 2

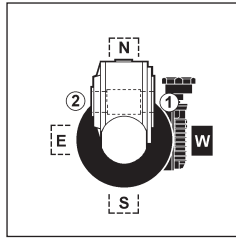

VF\_ B8 + V\_ B6 2

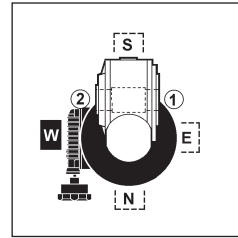

VF\_ B8 + V\_ B7 2

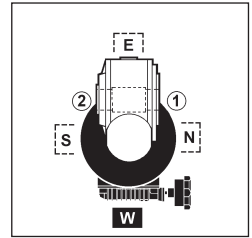

VF\_ B8 + V\_ B8 2

**VF\_P**

**V5**

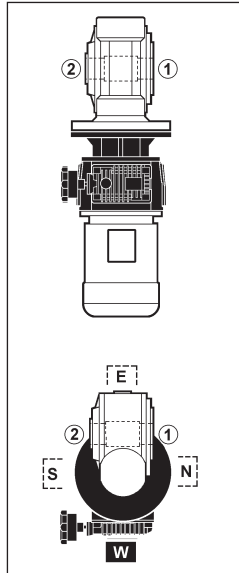

VF\_ V5 + V\_ V6 1

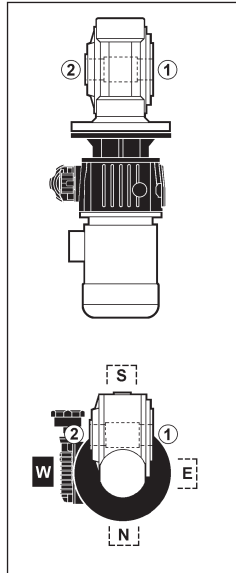

VF\_ V5 + V\_ V61 1

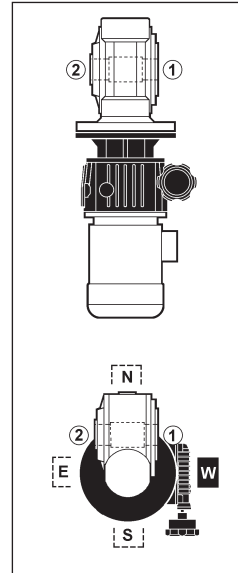

VF\_ V5 + V\_ V63 1

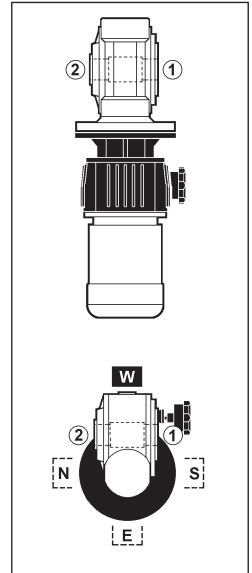

VF\_ V5 + V\_ V62 1

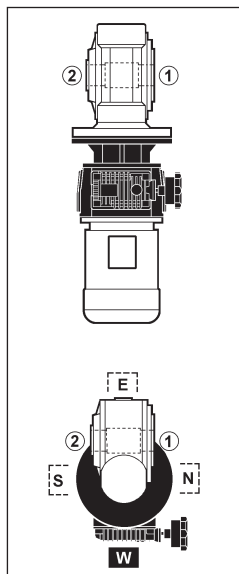

VF\_ V5 + V\_ V6 2

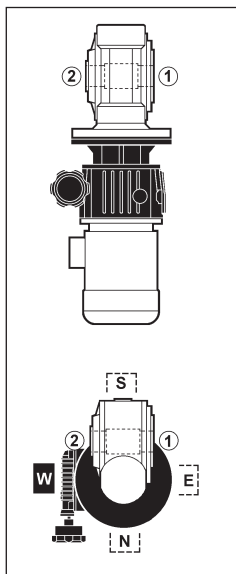

VF\_ V5 + V\_ V61 2

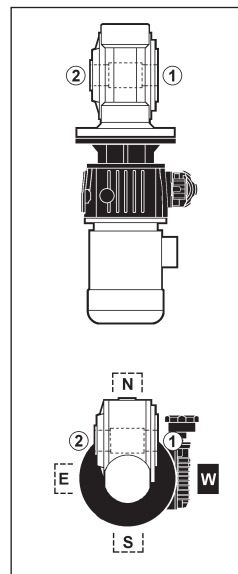

VF\_ V5 + V\_ V63 2

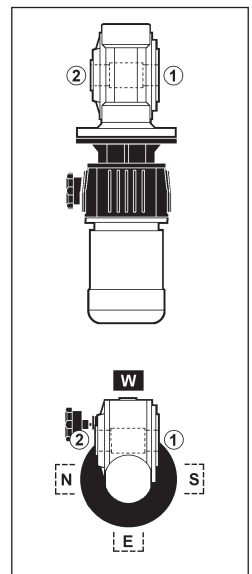

VF\_ V5 + V\_ V62 2

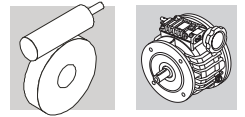

(F28)

**VF\_P**

**V6**

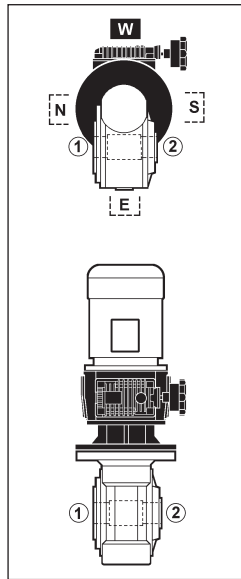

VF\_V6 + V\_V5 1

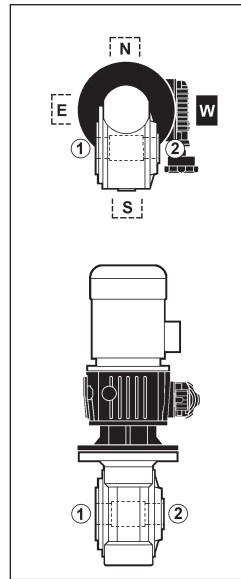

VF\_V6 + V\_V51 1

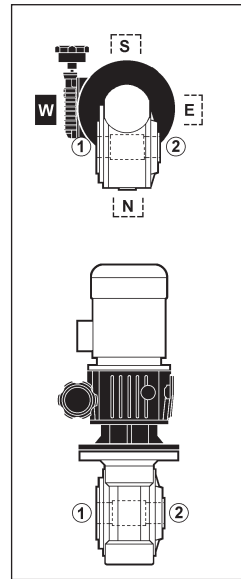

VF\_V6 + V\_V53 1

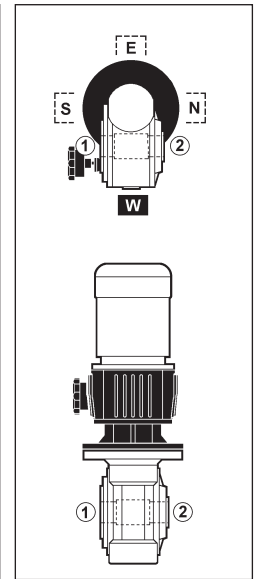

VF\_V6 + V\_V52 1

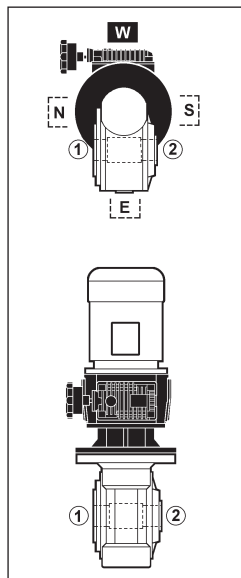

VF\_V6 + V\_V5 2

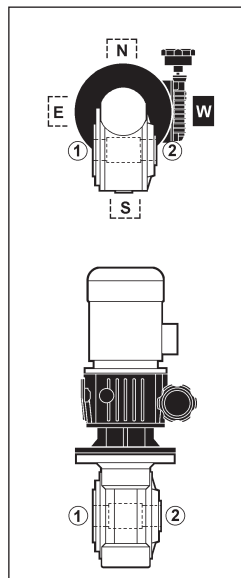

VF\_V6 + V\_V51 2

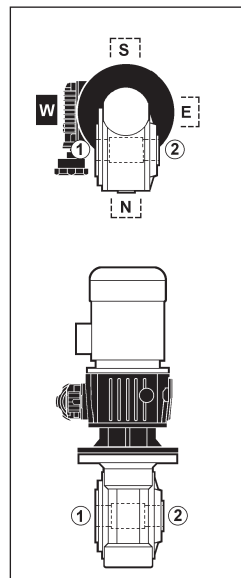

VF\_V6 + V\_V53 2

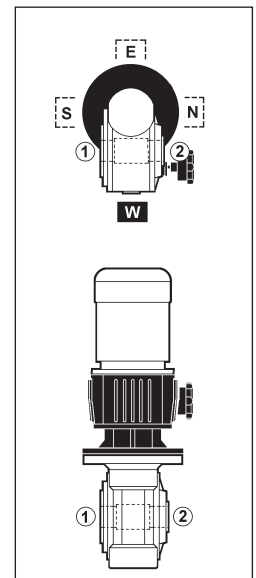

VF\_V6 + V\_V52 2

① ② Posizione flangia / Flange position / Flanschlage / Position bride

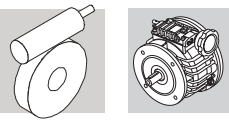

(F29)

<p><b>W_U</b></p>	<p><b>B3</b></p>				
		<p>W_ B3 + V_ B3 ①-②</p>	<p>W_ B3 + V_ B6 ①-②</p>	<p>W_ B3 + V_ B7 ①-②</p>	<p>W_ B3 + V_ B8 ①-②</p>
<p>W_U_B3 W_UF_B3 W_UFC_B3</p>					
<p><b>W_U</b></p>	<p><b>B6</b></p>				
		<p>W_ B6 + V_ B3 ①-②</p>	<p>W_ B6+ V_ B6 ①-②</p>	<p>W_ B6+ V_ B7 ①-②</p>	<p>W_ B6+ V_ B8 ①-②</p>
<p>W_U_B6 W_UF_B6 W_UFC_B6</p>					
<p><b>W_U</b></p>	<p><b>B7</b></p>				
		<p>W_ B7 + V_ B3 ①-②</p>	<p>W_ B7 + V_ B6 ①-②</p>	<p>W_ B7 + V_ B7 ①-②</p>	<p>W_ B7 + V_ B8 ①-②</p>
<p>W_U_B7 W_UF_B7 W_UFC_B7</p>					
<p><b>W_U</b></p>	<p><b>B8</b></p>				
		<p>W_ B8 + V_ B3 ①-②</p>	<p>W_ B8 + V_ B6 ①-②</p>	<p>W_ B8 + V_ B7 ①-②</p>	<p>W_ B8 + V_ B8 ①-②</p>
<p>W_U_B8 W_UF_B8 W_UFC_B8</p>					

① ② Posizione dispositivo di comando / Speed knob position / Eibaulage der Verstellrichtung / Position commande : 1 default, 2 (V 3...V 10)

① ② Posizione flangia / Flange position / Flanschlage / Position bride



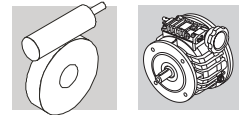

(F30)

**W\_U**

**V5**

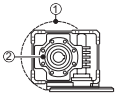

W\_U\_V5  
W\_UF\_V5  
W\_UFC\_V5

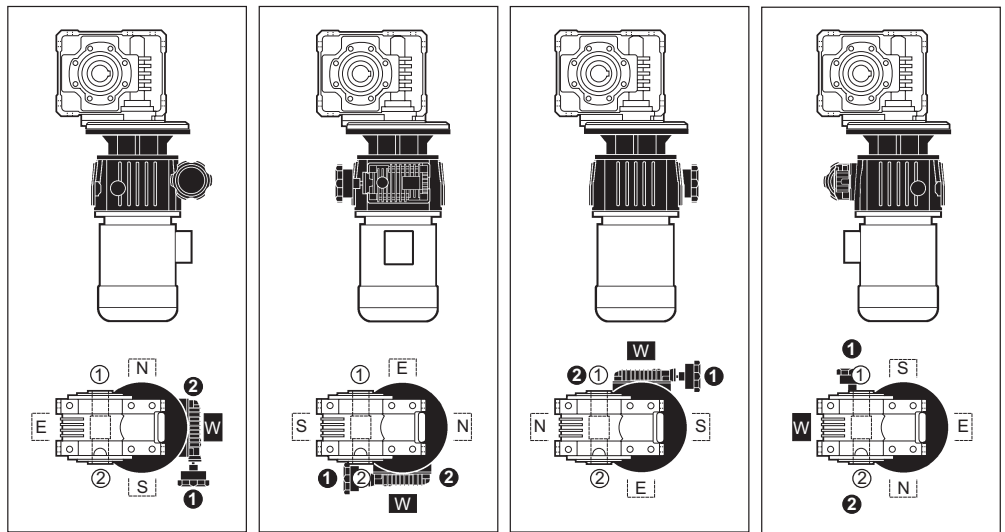

W\_ V5 + V\_ V6 1-2    W\_ V5 + V\_ V61 1-2    W\_ V5 + V\_ V63 1-2    W\_ V5 + V\_ 62 1-2

**W\_U**

**V6**

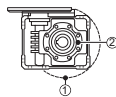

W\_U\_V6  
W\_UF\_V6  
W\_UFC\_V6

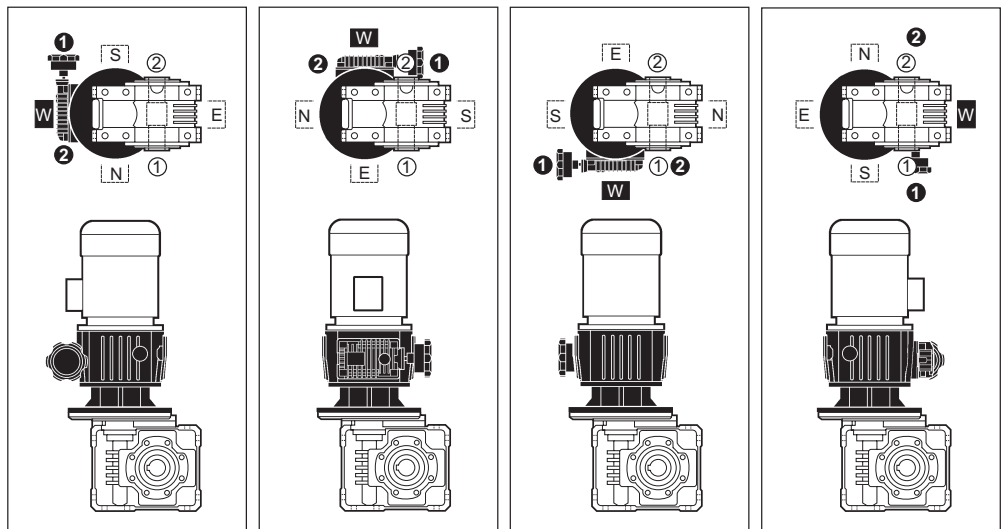

W\_ V6 + V\_ V5 1-2    W\_ V6 + V\_ V51 1-2    W\_ V6 + V\_ V53 1-2    W\_ V6 + V\_ V52 1-2

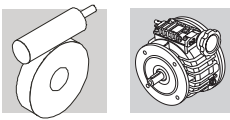

## 0.12 kW





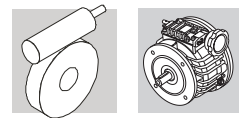

$n_2$ min <sup>-1</sup>	$n_2'$ min <sup>-1</sup>	$M_2$ Nm	$M_2'$ Nm	S	S'	i	$R_{n2}$ N	V-	P(IEC)		F		
7.6	1.6	50	127	1.2	0.5	80	3450	VF 49_80	<b>V025</b> P63	<b>V 0.25 C</b> V 0.25 F	<b>P63</b>	<b>BN63B6</b>	262-263
8.6	1.8	47	119	1.4	0.6	70	3450	VF 49_70	<b>V025</b> P63	<b>V 0.25 C</b> V 0.25 F	<b>P63</b>	<b>BN63B6</b>	262-263
10.1	2.1	43	109	1.5	0.6	60	3450	VF 49_60	<b>V025</b> P63	<b>V 0.25 C</b> V 0.25 F	<b>P63</b>	<b>BN63B6</b>	262-263
10.1	2.1	44	111	1.1	0.5	60	2500	VF 44_60	<b>V025</b> P63	<b>V 0.25 C</b> V 0.25 F	<b>P63</b>	<b>BN63B6</b>	260-261
13.1	2.7	37	94	1.3	0.5	46	2500	VF 44_46	<b>V025</b> P63	<b>V 0.25 C</b> V 0.25 F	<b>P63</b>	<b>BN63B6</b>	260-261
13.4	2.8	36	92	2.1	0.9	45	3450	VF 49_45	<b>V025</b> P63	<b>V 0.25 C</b> V 0.25 F	<b>P63</b>	<b>BN63B6</b>	262-263
16.8	3.5	31	79	2.5	1.0	36	3450	VF 49_36	<b>V025</b> P63	<b>V 0.25 C</b> V 0.25 F	<b>P63</b>	<b>BN63B6</b>	262-263
17.3	3.6	30	78	1.7	0.7	35	2500	VF 44_35	<b>V025</b> P63	<b>V 0.25 C</b> V 0.25 F	<b>P63</b>	<b>BN63B6</b>	260-261
21.6	4.5	25	65	3.3	1.3	28	3390	VF 49_28	<b>V025</b> P63	<b>V 0.25 C</b> V 0.25 F	<b>P63</b>	<b>BN63B6</b>	262-263
21.6	4.5	26	66	2.0	0.8	28	2500	VF 44_28	<b>V025</b> P63	<b>V 0.25 C</b> V 0.25 F	<b>P63</b>	<b>BN63B6</b>	260-261
25.2	5.2	24	60	3.0	1.2	24	3230	VF 49_24	<b>V025</b> P63	<b>V 0.25 C</b> V 0.25 F	<b>P63</b>	<b>BN63B6</b>	262-263
30	6.3	20	53	2.3	0.9	20	2500	VF 44_20	<b>V025</b> P63	<b>V 0.25 C</b> V 0.25 F	<b>P63</b>	<b>BN63B6</b>	260-261
34	6.9	19.0	48	3.8	1.5	18	2940	VF 49_18	<b>V025</b> P63	<b>V 0.25 C</b> V 0.25 F	<b>P63</b>	<b>BN63B6</b>	262-263
43	8.9	15.0	39	4.9	2.0	14	2720	VF 49_14	<b>V025</b> P63	<b>V 0.25 C</b> V 0.25 F	<b>P63</b>	<b>BN63B6</b>	262-263
43	8.9	15.0	39	3.1	1.3	14	2420	VF 44_14	<b>V025</b> P63	<b>V 0.25 C</b> V 0.25 F	<b>P63</b>	<b>BN63B6</b>	260-261
60	12.5	11.0	30	3.7	1.5	10	2170	VF 44_10	<b>V025</b> P63	<b>V 0.25 C</b> V 0.25 F	<b>P63</b>	<b>BN63B6</b>	260-261
86	17.9	8.0	21	5.1	2.1	7	1930	VF 44_7	<b>V025</b> P63	<b>V 0.25 C</b> V 0.25 F	<b>P63</b>	<b>BN63B6</b>	260-261

## 0.18 kW

8.6	1.8	67	129	1.0	0.5	70	3450	VF 49_70	<b>V025</b> P63	<b>V 0.25 C</b> V 0.25 F	<b>P63</b>	<b>BN71A6R</b>	262-263
10.1	2.1	61	118	1.1	0.6	60	3450	VF 49_60	<b>V025</b> P63	<b>V 0.25 C</b> V 0.25 F	<b>P63</b>	<b>BN71A6R</b>	262-263
11.4	2.4	56	138	1.0	0.4	80	3300	VF 49_80	<b>V025</b> P63	<b>V 0.25 C</b> V 0.25 F	<b>P63</b>	<b>BN63B4</b>	262-263
13.0	2.7	53	129	1.1	0.5	70	3300	VF 49_70	<b>V025</b> P63	<b>V 0.25 C</b> V 0.25 F	<b>P63</b>	<b>BN63B4</b>	262-263
15.2	3.2	48	118	1.3	0.6	60	3300	VF 49_60	<b>V025</b> P63	<b>V 0.25 C</b> V 0.25 F	<b>P63</b>	<b>BN63B4</b>	262-263
16.8	3.5	44	85	1.8	0.9	36	3450	VF 49_36	<b>V025</b> P63	<b>V 0.25 C</b> V 0.25 F	<b>P63</b>	<b>BN71A6R</b>	262-263
19.8	4.1	41	101	1.2	0.5	46	1300	VF 44_46	<b>V025</b> P63	<b>V 0.25 C</b> V 0.25 F	<b>P63</b>	<b>BN63B4</b>	260-261
20.2	4.2	40	99	1.8	0.8	45	3300	VF 49_45	<b>V025</b> P63	<b>V 0.25 C</b> V 0.25 F	<b>P63</b>	<b>BN63B4</b>	262-263
21.6	4.5	36	71	2.3	1.2	28	3300	VF 49_28	<b>V025</b> P63	<b>V 0.25 C</b> V 0.25 F	<b>P63</b>	<b>BN71A6R</b>	262-263
25.3	5.3	34	85	2.2	0.9	36	3150	VF 49_36	<b>V025</b> P63	<b>V 0.25 C</b> V 0.25 F	<b>P63</b>	<b>BN63B4</b>	262-263
26.0	5.4	34	84	1.5	0.7	35	1300	VF 44_35	<b>V025</b> P63	<b>V 0.25 C</b> V 0.25 F	<b>P63</b>	<b>BN63B4</b>	260-261



## 0.18 kW





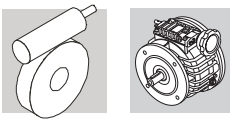

$n_2$ min <sup>-1</sup>	$n_2'$ min <sup>-1</sup>	M <sub>2</sub> Nm	M <sub>2'</sub> Nm	S	S'	i	R <sub>n2</sub> N	 V-  P(IEC)	 C  F				
30	6.3	29	58	1.6	0.9	20	2500	VF 44_20	V025 P63	V 0.25 C V 0.25 F	P63	BN71A6R	260-261
33	6.8	28	71	2.9	1.2	28	2910	VF 49_28	V025 P63	V 0.25 C V 0.25 F	P63	BN63B4	262-263
33	6.8	28	72	1.7	0.8	28	1300	VF 44_28	V025 P63	V 0.25 C V 0.25 F	P63	BN63B4	260-261
38	7.9	26	65	2.7	1.1	24	2780	VF 49_24	V025 P63	V 0.25 C V 0.25 F	P63	BN63B4	262-263
43	8.9	22	43	2.2	1.2	14	2360	VF 44_14	V025 P63	V 0.25 C V 0.25 F	P63	BN71A6R	260-261
46	9.5	22	58	2.0	0.9	20	1300	VF 44_20	V025 P63	V 0.25 C V 0.25 F	P63	BN63B4	260-261
51	10.6	20	52	3.4	1.4	18	2450	VF 49_18	V025 P63	V 0.25 C V 0.25 F	P63	BN63B4	262-263
60	12.5	16.0	32	2.6	1.4	10	2120	VF 44_10	V025 P63	V 0.25 C V 0.25 F	P63	BN71A6R	260-261
65	13.6	16.0	42	4.3	1.9	14	2350	VF 49_14	V025 P63	V 0.25 C V 0.25 F	P63	BN63B4	262-263
65	13.6	16.0	43	2.4	1.2	14	2080	VF 44_14	V025 P63	V 0.25 C V 0.25 F	P63	BN63B4	260-261
86	17.9	12.0	23	3.6	1.9	7	1890	VF 44_7	V025 P63	V 0.25 C V 0.25 F	P63	BN71A6R	260-261
91	19.0	12.0	32	5.2	2.3	10	2110	VF 49_10	V025 P63	V 0.25 C V 0.25 F	P63	BN63B4	262-263
91	19.0	12.0	32	3.2	1.4	10	1870	VF 44_10	V025 P63	V 0.25 C V 0.25 F	P63	BN63B4	260-261
130	27.1	9.0	23	4.4	1.9	7	1660	VF 44_7	V025 P63	V 0.25 C V 0.25 F	P63	BN63B4	260-261

## 0.25 kW

6.6	1.3	150	352	1.1	0.5	100	6200	W 75_100	— P71	— V 0.5 F	P71	BN71B6	265
8.3	1.6	130	314	1.5	0.7	80	6200	W 75_80	— P71	— V 0.5 F	P71	BN71B6	265
8.3	1.6	125	294	1.0	0.5	80	5000	W 63_80	V05 P71	V 0.5 C V 0.5 F	P71	BN71B6	264
10.0	1.9	100	220	1.6	0.8	100	6200	W 75_100	— P71	— V 0.5 F	P71	BN71A4	265
10.0	1.9	92	205	1.3	0.6	100	5000	W 63_100	V05 P71	V 0.5 C V 0.5 F	P71	BN71A4	264
11.1	2.1	108	264	2.0	0.9	60	6200	W 75_60	— P71	— V 0.5 F	P71	BN71B6	265
12.5	2.4	86	196	2.3	1.1	80	6200	W 75_80	— P71	— V 0.5 F	P71	BN71A4	265
12.5	2.4	83	184	1.5	0.7	80	5000	W 63_80	V05 P71	V 0.5 C V 0.5 F	P71	BN71A4	264
13.0	2.7	63	129	1.0	0.5	70	3300	VF 49_70	V025 P63	V 0.25 C V 0.25 F	P63	BN63C4	262-263
14.7	2.8	85	209	1.8	0.8	45	5000	W 63_45	V05 P71	V 0.5 C V 0.5 F	P71	BN71B6	264
15.2	3.2	57	118	1.1	0.6	60	3300	VF 49_60	V025 P63	V 0.25 C V 0.25 F	P63	BN63C4	262-263
15.6	3.0	81	186	3.7	1.8	64	7000	W 86_64	— P71	— V 0.5 F	P71	BN71A4	266
16.7	3.2	72	165	3.0	1.4	60	6200	W 75_60	— P71	— V 0.5 F	P71	BN71A4	265
18.4	3.5	66	170	1.2	0.5	36	3270	VF 49_36	V05 P71	V 0.5 C V 0.5 F	P71	BN71B6	262-263
19.8	4.1	49	101	1.0	0.5	46	2300	VF 44_46	V025 P63	V 0.25 C V 0.25 F	P63	BN63C4	260-261
20.0	3.8	63	145	3.7	1.8	50	6200	W 75_50	— P71	— V 0.5 F	P71	BN71A4	265
20.2	4.2	48	99	1.5	0.8	45	3300	VF 49_45	V025 P63	V 0.25 C V 0.25 F	P63	BN63C4	262-263



## 0.25 kW

$n_2$ min <sup>-1</sup>	$n_2'$ min <sup>-1</sup>	$M_2$ Nm	$M_2'$ Nm	S	S'	i	R <sub>n2</sub> N	 V-  P(IEC)	 C  F	 IEC			
22.2	4.2	53	124	1.3	0.6	45	3150	VF 49_45	V05 P71	V 0.5 C V 0.5 F	P71	BN71A4	262-263
22.2	4.2	57	131	2.7	1.3	45	5000	W 63_45	V05 P71	V 0.5 C V 0.5 F	P71	BN71A4	264
23.7	4.5	55	141	1.6	0.6	28	3040	VF 49_28	V05 P71	V 0.5 C V 0.5 F	P71	BN71B6	262-263
25.3	5.3	41	85	1.8	0.9	36	3100	VF 49_36	V025 P63	V 0.25 C V 0.25 F	P63	BN63C4	262-263
26.0	5.4	40	84	1.2	0.7	35	2300	VF 44_35	V025 P63	V 0.25 C V 0.25 F	P63	BN63C4	260-261
26.3	5.0	50	116	3.3	1.6	38	4790	W 63_38	V05 P71	V 0.5 C V 0.5 F	P71	BN71A4	264
27.8	5.3	45	106	1.7	0.8	36	2960	VF 49_36	V05 P71	V 0.5 C V 0.5 F	P71	BN71A4	262-263
30	6.3	38	76	1.1	0.9	60	2970	VF 49_60	V025 P63	V 0.25 C V 0.25 F	P63	BN63B2	262-263
33	6.8	34	71	2.4	1.2	28	2870	VF 49_28	V025 P63	V 0.25 C V 0.25 F	P63	BN63C4	262-263
33	6.8	34	72	1.5	0.8	28	2300	VF 44_28	V025 P63	V 0.25 C V 0.25 F	P63	BN63C4	260-261
33	6.3	42	96	4.0	2.0	30	4460	W 63_30	V05 P71	V 0.5 C V 0.5 F	P71	BN71A4	264
35	6.6	44	111	3.6	1.6	19	4360	W 63_19	V05 P71	V 0.5 C V 0.5 F	P71	BN71B6	264
36	6.8	38	88	2.2	1.0	28	2740	VF 49_28	V05 P71	V 0.5 C V 0.5 F	P71	BN71A4	262-263
38	7.9	31	65	2.2	1.1	24	2740	VF 49_24	V025 P63	V 0.25 C V 0.25 F	P63	BN63C4	262-263
40	8.4	31	64	1.6	1.2	45	2710	VF 49_45	V025 P63	V 0.25 C V 0.25 F	P63	BN63B2	262-263
42	7.9	36	84	4.6	2.2	24	4160	W 63_24	V05 P71	V 0.5 C V 0.5 F	P71	BN71A4	264
42	7.9	34	82	2.0	0.9	24	2620	VF 49_24	V05 P71	V 0.5 C V 0.5 F	P71	BN71A4	262-263
44	8.3	36	91	4.4	2.0	15	4060	W 63_15	V05 P71	V 0.5 C V 0.5 F	P71	BN71B6	264
46	9.5	27	58	1.7	0.9	20	2290	VF 44_20	V025 P63	V 0.25 C V 0.25 F	P63	BN63C4	260-261
47	8.9	32	84	2.3	0.9	14	2490	VF 49_14	V05 P71	V 0.5 C V 0.5 F	P71	BN71B6	262-263
51	10.6	24	52	2.8	1.4	18	2510	VF 49_18	V025 P63	V 0.25 C V 0.25 F	P63	BN63C4	262-263
52	10.9	26	55	1.1	1.0	35	2230	VF 44_35	V025 P63	V 0.25 C V 0.25 F	P63	BN63B2	260-261
53	10.0	30	69	5.4	2.6	19	3870	W 63_19	V05 P71	V 0.5 C V 0.5 F	P71	BN71A4	264
56	10.6	27	65	2.5	1.1	18	2400	VF 49_18	V05 P71	V 0.5 C V 0.5 F	P71	BN71A4	262-263
65	13.6	21	46	2.7	1.9	28	2340	VF 49_28	V025 P63	V 0.25 C V 0.25 F	P63	BN63B2	262-263
65	13.6	20	42	3.6	1.9	14	2320	VF 49_14	V025 P63	V 0.25 C V 0.25 F	P63	BN63C4	262-263
65	13.6	21	47	1.4	1.2	28	2080	VF 44_28	V025 P63	V 0.25 C V 0.25 F	P63	BN63B2	260-261
65	13.6	20	43	2.0	1.2	14	2050	VF 44_14	V025 P63	V 0.25 C V 0.25 F	P63	BN63C4	260-261
71	13.6	22	53	3.3	1.5	14	2230	VF 49_14	V05 P71	V 0.5 C V 0.5 F	P71	BN71A4	262-263
76	15.8	19.0	42	2.5	1.7	24	2230	VF 49_24	V025 P63	V 0.25 C V 0.25 F	P63	BN63B2	262-263
91	19.0	16.0	37	1.8	1.3	20	1870	VF 44_20	V025 P63	V 0.25 C V 0.25 F	P63	BN63B2	260-261
91	19.0	15.0	32	4.3	2.3	10	2090	VF 49_10	V025 P63	V 0.25 C V 0.25 F	P63	BN63C4	262-263
91	19.0	15.0	32	2.6	1.4	10	1840	VF 44_10	V025 P63	V 0.25 C V 0.25 F	P63	BN63C4	260-261
100	19.0	16.0	40	3.9	1.9	10	2000	VF 49_10	V05 P71	V 0.5 C V 0.5 F	P71	BN71A4	262-263
101	21.1	15.0	34	3.0	2.2	18	2040	VF 49_18	V025 P63	V 0.25 C V 0.25 F	P63	BN63B2	262-263

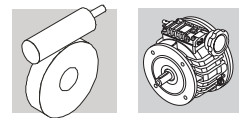

## 0.25 kW





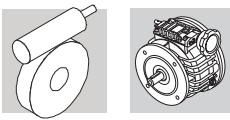

$n_2$ min <sup>-1</sup>	$n_2'$ min <sup>-1</sup>	M <sub>2</sub> Nm	M <sub>2'</sub> Nm	S	S'	i	R <sub>n2</sub> N	V-  P(IEC)	C  F	IEC			
130	27.1	12.0	28	1.9	1.8	14	1670	VF 44_14	V025 P63	V 0.25 C V 0.25 F	P63	BN63B2	260-261
130	27.1	11.0	23	3.6	1.9	7	1640	VF 44_7	V025 P63	V 0.25 C VBG 0.25 F	P63	BN63C4	260-261
143	27.1	12.0	29	5.1	2.5	7	1790	VF 49_7	V05 P71	V 0.5 C V 0.5 F	P71	BN71A4	262-263
182	38	9.0	21	2.5	2.2	10	1500	VF 44_10	V025 P63	V 0.25 C V 0.25 F	P63	BN63B2	260-261
260	54	6.0	15.0	3.6	3.0	7	1330	VF 44_7	V025 P63	V 0.25 C V 0.25 F	P63	BN63B2	260-261

## 0.37 kW

8.3	1.6	173	314	1.1	0.7	80	6200	W 75_80	— P71	— V 0.5 F	P71	BN71C6	265
10.0	1.9	150	352	1.1	0.5	100	6200	W 75_100	— P71	— V 0.5 F	P71	BN71B4	265
10.4	2.0	143	261	0.9	0.6	64	5000	W 63_64	V05 P71	V 0.5 C V 0.5 F	P71	BN71C6	264
12.5	2.4	130	314	1.5	0.7	80	6200	W 75_80	— P71	— V 0.5 F	P71	BN71B4	265
12.5	2.4	125	294	1.0	0.5	80	5000	W 63_80	V05 P71	V 0.5 C V 0.5 F	P71	BN71B4	264
14.7	2.8	113	209	1.4	0.8	45	5000	W 63_45	V05 P71	V 0.5 C V 0.5 F	P71	BN71C6	264
15.6	3.0	108	261	1.3	0.6	64	5000	W 63_64	V05 P71	V 0.5 C V 0.5 F	P71	BN71B4	264
16.7	3.2	108	264	2.0	0.9	60	6200	W 75_60	— P71	— V 0.5 F	P71	BN71B4	265
17.4	3.3	100	185	1.6	1.0	38	5000	W 63_38	V05 P71	V 0.5 C V 0.5 F	P71	BN71C6	264
20.0	3.8	95	232	2.5	1.1	50	6200	W 75_50	— P71	— V 0.5 F	P71	BN71B4	265
22.2	4.2	85	209	1.8	0.8	45	4850	W 63_45	V05 P71	V 0.5 C V 0.5 F	P71	BN71B4	264
23.7	4.5	73	141	1.2	0.6	28	2900	VF 49_28	V05 P71	V 0.5 C V 0.5 F	P71	BN71C6	262-263
26.3	5.0	75	185	2.2	1.0	38	4620	W 63_38	V05 P71	V 0.5 C V 0.5 F	P71	BN71B4	264
27.6	5.2	72	134	2.3	1.4	24	4550	W 63_24	V05 P71	V 0.5 C V 0.5 F	P71	BN71C6	264
27.8	5.3	68	170	1.1	0.5	36	2790	VF 49_36	V05 P71	V 0.5 C V 0.5 F	P71	BN71B4	262-263
33	6.3	63	154	2.7	1.2	30	4310	W 63_30	V05 P71	V 0.5 C V 0.5 F	P71	BN71B4	264
35	6.6	59	111	2.7	1.6	19	4250	W 63_19	V05 P71	V 0.5 C V 0.5 F	P71	BN71C6	264
36	6.8	56	141	1.5	0.6	28	2600	VF 49_28	V05 P71	V 0.5 C V 0.5 F	P71	BN71B4	262-263
40	8.4	47	99	1.1	0.8	45	2610	VF 49_45	V025 P63	V 0.25 C V 0.25 F	P63	BN63C2	262-263
42	7.9	54	134	3.1	1.4	24	4030	W 63_24	V05 P71	V 0.5 C V 0.5 F	P71	BN71B4	264
42	7.9	51	131	1.3	0.6	24	2490	VF 49_24	V05 P71	V 0.5 C V 0.5 F	P71	BN71B4	262-263
44	8.3	48	91	3.3	2.0	15	3970	W 63_15	V05 P71	V 0.5 C V 0.5 F	P71	BN71C6	264
51	10.6	39	85	1.3	0.9	36	2450	VF 49_36	V025 P63	V 0.25 C V 0.25 F	P63	BN63C2	262-263
53	10.0	44	111	3.6	1.6	19	3760	W 63_19	V05 P71	V 0.5 C V 0.5 F	P71	BN71B4	264
56	10.6	41	104	1.7	0.7	18	2290	VF 49_18	V05 P71	V 0.5 C V 0.5 F	P71	BN71B4	262-263
65	13.6	32	71	1.8	1.2	28	2270	VF 49_28	V025 P63	V 0.25 C V 0.25 F	P63	BN63C2	262-263



## 0.37 kW

$n_2$ min <sup>-1</sup>	$n_2'$ min <sup>-1</sup>	M <sub>2</sub> Nm	M <sub>2</sub> ' Nm	S	S'	i	R <sub>n2</sub> N	 	 				
67	12.7	36	91	4.4	2.0	15	3500	W 63_15	V05 P71	V 0.5 C V 0.5 F	P71	BN71B4	264
71	13.6	33	84	2.2	0.9	14	2140	VF 49_14	V05 P71	V 0.5 C V 0.5 F	P71	BN71B4	262-263
76	15.8	28	65	1.7	1.1	24	2160	VF 49_24	V025 P63	V 0.25 C V 0.25 F	P63	BN63C2	262-263
91	19.0	24	58	1.2	0.9	20	1810	VF 44_20	V025 P63	V 0.25 C V 0.25 F	P63	BN63C2	260-261
95	17.9	24	46	2.8	1.6	7	1950	VF 49_7	V05 P71	V 0.5 C V 0.5 F	P71	BN71C6	262-263
100	19.0	25	65	6.0	2.5	10	5000	W 63_10	V05 P71	V 0.5 C V 0.5 F	P71	BN71B4	264
100	19.0	25	64	2.6	1.2	10	1930	VF 49_10	V05 P71	V 0.5 C V 0.5 F	P71	BN71B4	262-263
101	21.1	22	52	2.0	1.4	18	1980	VF 49_18	V025 P63	V 0.25 C V 0.25 F	P63	BN63C2	262-263
130	27.1	18.0	42	2.8	1.9	14	1840	VF 49_14	V025 P63	V 0.25 C V 0.25 F	P63	BN63C2	262-263
130	27.1	18.0	43	1.2	1.2	14	1620	VF 44_14	V025 P63	V 0.25 C V 0.25 F	P63	BN63C2	260-261
143	27.1	18.0	46	3.4	1.6	7	1730	VF 49_7	V05 P71	V 0.5 C V 0.5 F	P71	BN71B4	262-263
182	38	13.0	32	3.4	2.3	10	1650	VF 49_10	V025 P63	V 0.25 C V 0.25 F	P63	BN63C2	262-263
260	54	9.0	23	2.4	1.9	7	1300	VF 44_7	V025 P63	V 0.25 C V 0.25 F	P63	BN63C2	260-261

## 0.55 kW

6.6	1.3	342	816	1.4	0.7	100	8000	W 110_100	— P80	— V 1 F	P80	BN80B6	267
8.3	1.6	293	717	1.7	0.8	80	8000	W 110_80	— P80	— V 1 F	P80	BN80B6	267
8.3	1.6	283	678	1.0	0.4	80	7000	W 86_80	V1 P80	V 1 C V 1 F	P80	BN80B6	266
10.0	1.9	257	612	1.9	0.9	100	8000	W 110_100	— P80	— V 1 F	P80	BN80A4	267
10.0	1.9	248	392	1.0	0.7	100	7000	W 86_100	— P71	— V 0.5 F	P80	BN80A4	266
10.4	2.0	250	614	2.3	1.0	64	8000	W 110_64	— P80	— V 1 F	P80	BN80B6	267
10.4	2.0	242	594	1.2	0.6	64	7000	W 86_64	V1 P80	V 1 C V 1 F	P80	BN80B6	266
11.8	2.2	228	564	2.8	1.3	56	8000	W 110_56	— P80	— V 1 F	P80	BN80B6	267
11.8	2.2	222	269	1.5	1.3	56	7000	W 86_56	— P71	— V 0.5 F	P80	BN80B6	266
12.5	2.4	212	509	1.3	0.6	80	7000	W 86_80	V1 P80	V 1 C V 1 F	P80	BN80A4	266
12.5	2.4	194	470	1.0	0.5	80	6200	W 75_80	V1 P80	V 1 C V 1 F	P80	BN80A4	265
14.4	2.7	196	486	3.3	1.5	46	8000	W 110_46	— P80	— V 1 F	P80	BN80B6	267
15.6	3.0	181	445	1.7	0.7	64	7000	W 86_64	V1 P80	V 1 C V 1 F	P80	BN80A4	266
16.6	3.1	163	403	1.7	0.8	40	6200	W 75_40	V1 P80	V 1 C V 1 F	P80	BN80B6	265
16.7	3.2	162	396	1.3	0.6	60	6200	W 75_60	V1 P80	V 1 C V 1 F	P80	BN80A4	265
17.9	3.4	166	403	2.0	0.9	56	7000	W 86_56	V1 P80	V 1 C V 1 F	P80	BN80A4	266
20.0	3.8	142	348	1.7	0.7	50	6200	W 75_50	V1 P80	V 1 C V 1 F	P80	BN80A4	265

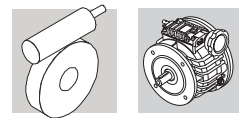





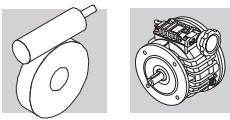

## 0.55 kW

$n_2$ min <sup>-1</sup>	$n_2'$ min <sup>-1</sup>	M <sub>2</sub> Nm	M <sub>2'</sub> Nm	S	S'	i	R <sub>n2</sub> N						
21.7	4.1	143	348	2.6	1.2	46	7000	W 86_46	V1 P80	V 1 C V 1 F	P80	BN80A4	266
22.1	4.2	133	331	2.2	1.0	30	6200	W 75_30	V1 P80	V 1 C V 1 F	P80	BN80B6	265
22.2	4.2	128	209	1.2	0.8	45	5000	W 63_45	V05 P71	V 0.5 C V 0.5 F	P80	BN80A4	264
22.2	4.2	128	313	1.2	0.5	45	5000	W 63_45	V1 P80	V 1 C V 1 F	P80	BN80A4	264
25.0	4.8	128	317	2.8	1.2	40	7000	W 86_40	V1 P80	V 1 C V 1 F	P80	BN80A4	266
25.0	4.8	122	302	2.2	1.0	40	6200	W 75_40	V1 P80	V 1 C V 1 F	P80	BN80A4	265
25.0	4.8	104	196	1.5	1.1	80	6200	W 75_80	— P71	— V 0.5 F	P71	BN71B2	265
26.3	5.0	113	185	1.5	1.0	38	4360	W 63_38	V05 P71	V 0.5 C V 0.5 F	P80	BN80A4	264
26.3	5.0	113	278	1.5	0.7	38	4360	W 63_38	V1 P80	V 1 C V 1 F	P80	BN80A4	264
27.6	5.2	108	269	1.5	0.7	24	4300	W 63_24	V1 P80	V 1 C V 1 F	P80	BN80B6	264
31	5.9	86	163	1.3	0.9	64	4360	W 63_64	V05 P71	V 0.5 C V 0.5 F	P71	BN71B2	264
33	6.3	100	248	2.9	1.3	30	5700	W 75_30	V1 P80	V 1 C V 1 F	P80	BN80A4	265
33	6.3	95	154	1.8	1.2	30	4080	W 63_30	V05 P71	V 0.5 C V 0.5 F	P80	BN80A4	264
33	6.3	95	230	1.8	0.8	30	4080	W 63_30	V1 P80	V 1 C V 1 F	P80	BN80A4	264
35	6.6	89	222	1.8	0.8	19	4040	W 63_19	V1 P80	V 1 C V 1 F	P80	BN80B6	264
40	7.6	87	219	3.1	1.3	25	5400	W 75_25	V1 P80	V 1 C V 1 F	P80	BN80A4	265
40	7.6	73	145	2.7	1.8	50	5530	W 75_50	— P71	— V 0.5 F	P71	BN71B2	265
42	7.9	81	134	2.0	1.4	24	38470	W 63_24	V05 P71	V 0.5 C V 0.5 F	P80	BN80A4	264
42	7.9	81	202	2.0	0.9	24	5000	W 63_24	V1 P80	V 1 C V 1 F	P80	BN80A4	264
44	8.3	74	187	4.8	2.1	15	7000	W 86_15	V1 P80	V 1 C V 1 F	P80	BN80B6	266
44	8.4	66	131	2.0	1.3	45	3930	W 63_45	V05 P71	V 0.5 C V 0.5 F	P71	BN71B2	264
50	9.5	72	185	3.8	1.6	20	5050	W 75_20	V1 P80	V 1 C V 1 F	P80	BN80A4	265
53	10.0	67	111	2.4	1.6	19	3600	W 63_19	V05 P71	V 0.5 C V 0.5 F	P80	BN80A4	264
53	10.0	67	166	2.4	1.1	19	3600	W 63_19	V1 P80	V 1 C V 1 F	P80	BN80A4	264
56	10.6	52	106	1.0	0.8	36	2280	VF 49_36	V05 P71	V 0.5 C V 0.5 F	P71	BN71B2	262-263
66	12.5	50	130	3.0	1.3	10	3370	W 63_10	V1 P80	V 1 C V 1 F	P80	BN80B6	264
67	12.7	54	91	3.0	2.0	15	3370	W 63_15	V05 P71	V 0.5 C V 0.5 F	P80	BN80A4	264
67	12.7	54	137	3.0	1.3	15	3370	W 63_15	V1 P80	V 1 C V 1 F	P80	BN80A4	264
71	13.6	42	88	1.3	1.0	28	2120	VF 49_28	V05 P71	V 0.5 C V 0.5 F	P71	BN71B2	262-263
83	15.8	38	82	1.2	0.9	24	2020	VF 49_24	V05 P71	V 0.5 C V 0.5 F	P71	BN71B2	262-263
83	15.8	44	76	3.4	2.2	12	3150	W 63_12	V05 P71	V 0.5 C V 0.5 F	P80	BN80A4	264
95	17.9	37	94	3.6	1.5	7	3030	W 63_7	V1 P80	V 1 C V 1 F	P80	BN80B6	264
100	19.0	38	65	4.0	2.5	10	2990	W 63_10	V05 P71	V 0.5 C V 0.5 F	P80	BN80A4	264



## 0.55 kW

$n_2$ min <sup>-1</sup>	$n_2'$ min <sup>-1</sup>	M <sub>2</sub> Nm	M <sub>2'</sub> Nm	S	S'	i	R <sub>n2</sub> N	 V	 P(IEC)	 C	 F	 IEC	
100	19.0	38	97	4.0	1.7	10	2990	W 63_10	V1 P80	V 1 C V 1 F	P80	BN80A4	264
105	20.0	32	69	4.1	2.6	19	3030	W 63_19	V05 P71	V 0.5 C V 0.5 F	P71	BN71B2	264
111	21.1	30	65	1.5	1.1	18	1860	VF 49_18	V05 P71	V 0.5 C V 0.5 F	P71	BN71B2	262-263
143	27.1	27	47	4.7	3.0	7	2680	W 63_7	V05 P71	V 0.5 C V 0.5 F	P80	BN80A4	264
143	27.1	27	71	4.7	2.0	7	2680	W 63_7	V1 P80	V 1 C V 1 F	P80	BN80A4	264
143	27.1	24	53	2.1	1.5	14	1730	VF 49_14	V05 P71	V 0.5 C V 0.5 F	P71	BN71B2	262-263
200	38	17.0	40	2.6	1.9	10	1560	VF 49_10	V05 P71	V 0.5 C V 0.5 F	P71	BN71B2	262-263
286	54	12.0	29	3.3	2.5	7	1400	VF 49_7	V05 P71	V 0.5 C V 0.5 F	P71	BN71B2	262-263

## 0.75 kW

6.6	1.3	456	816	1.1	0.7	100	8000	W 110_100	— P80	— V 1 F	P80	BN80C6	267
8.3	1.6	390	717	1.3	0.8	80	8000	W 110_80	— P80	— V 1 F	P80	BN80C6	267
10.0	1.9	342	816	1.4	0.7	100	8000	W 110_100	— P80	— V 1 F	P80	BN80B4	267
10.4	2.0	323	594	0.9	0.6	64	7000	W 86_64	V1 P80	V 1 C V 1 F	P80	BN80C6	266
11.8	2.2	305	564	2.1	1.3	56	8000	W 110_56	— P80	— V 1 F	P80	BN80C6	267
11.8	2.2	296	538	1.1	0.7	56	7000	W 86_56	V1 P80	V 1 C V 1 F	P80	BN80C6	266
12.5	2.4	293	717	1.7	0.8	80	8000	W 110_80	— P80	— V 1 F	P80	BN80B4	267
12.5	2.4	283	678	1.0	0.4	80	7000	W 86_80	V1 P80	V 1 C V 1 F	P80	BN80B4	266
14.4	2.7	254	464	1.4	0.9	46	7000	W 86_46	V1 P80	V 1 C V 1 F	P80	BN80C6	266
15.6	3.0	250	614	2.3	1.0	64	8000	W 110_64	— P80	— V 1 F	P80	BN80B4	267
15.6	3.0	242	594	1.2	0.6	64	7000	W 86_64	V1 P80	V 1 C V 1 F	P80	BN80B4	266
16.6	3.1	218	403	1.3	0.8	40	6200	W 75_40	V1 P80	V 1 C V 1 F	P80	BN80C6	265
17.4	3.3	201	371	0.8	0.5	38	4200	W 63_38	V1 P80	V 1 C V 1 F	P80	BN80C6	264
17.9	3.4	228	564	2.8	1.3	56	8000	W 110_56	— P80	— V 1 F	P80	BN80B4	267
17.9	3.4	222	538	1.5	0.7	56	7000	W 86_56	V1 P80	V 1 C V 1 F	P80	BN80B4	266
20.0	3.8	189	464	1.2	0.6	50	6200	W 75_50	V1 P80	V 1 C V 1 F	P80	BN80B4	265
21.7	4.1	196	486	3.3	1.5	46	8000	W 110_46	— P80	— V 1 F	P80	BN80B4	267
21.7	4.1	190	464	1.9	0.9	46	7000	W 86_46	V1 P80	V 1 C V 1 F	P80	BN80B4	266
25.0	4.8	175	435	4.1	1.8	40	8000	W 110_40	— P80	— V 1 F	P80	BN80B4	267
25.0	4.8	170	422	2.1	0.9	40	7000	W 86_40	V1 P80	V 1 C V 1 F	P80	BN80B4	266
25.0	4.8	163	403	1.7	0.8	40	5960	W 75_40	V1 P80	V 1 C V 1 F	P80	BN80B4	265
26.3	5.0	150	185	1.1	1.0	38	4090	W 63_38	V05 P71	V 0.5 C V 0.5 F	P80	BN80B4	264



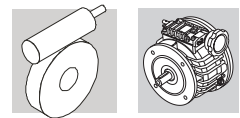

# 0.75 kW

$n_2$ min <sup>-1</sup>	$n_2'$ min <sup>-1</sup>	M <sub>2</sub> Nm	M <sub>2</sub> ' Nm	S	S'	i	R <sub>n2</sub> N	V-  P(IEC)	C  F	IEC			
26.5	5.0	154	292	1.8	1.0	25	5860	W 75_25	V1 P80	V 1 C V 1 F	P80	BN80C6	265
27.6	5.2	144	269	1.1	0.7	24	4040	W 63_24	V1 P80	V 1 C V 1 F	P80	BN80C6	264
33	6.3	128	246	2.1	1.2	20	5500	W 75_20	V1 P80	V 1 C V 1 F	P80	BN80C6	265
33	6.3	126	264	1.4	0.9	60	5630	W 75_60	— P71	— V 0.5 F	P71	BN71C2	265
33	6.3	126	154	1.3	1.2	30	3860	W 63_30	V05 P71	V 0.5 C V 0.5 F	P80	BN80B4	264
33	6.3	126	307	1.3	0.6	30	3860	W 63_30	V1 P80	V 1 C V 1 F	P80	BN80B4	264
35	6.6	119	222	1.3	0.8	19	3820	W 63_19	V1 P80	V 1 C V 1 F	P80	BN80C6	264
40	7.6	116	292	2.3	1.0	25	5220	W 75_25	V1 P80	V 1 C V 1 F	P80	BN80B4	265
40	7.6	110	232	1.8	1.1	50	5340	W 75_50	— P71	— V 0.5 F	P71	BN71C2	265
42	7.9	108	134	1.5	1.4	24	3650	W 63_24	V05 P71	V 0.5 C V 0.5 F	P80	BN80B4	264
42	7.9	108	269	1.5	0.7	24	3650	W 63_24	V1 P80	V 1 C V 1 F	P80	BN80B4	264
44	8.3	100	192	2.7	1.5	15	5080	W 75_15	V1 P80	V 1 C V 1 F	P80	BN80C6	265
44	8.3	96	182	1.7	1.0	15	3600	W 63_15	V1 P80	V 1 C V 1 F	P80	BN80C6	264
44	8.4	99	209	1.3	0.8	45	3730	W 63_45	V05 P71	V 0.5 C V 0.5 F	P71	BN71C2	264
50	9.5	96	246	2.8	1.2	20	4900	W 75_20	V1 P80	V 1 C V 1 F	P80	BN80B4	265
53	10.0	89	111	1.8	1.6	19	3440	W 63_19	V05 P71	V 0.5 C V 0.5 F	P80	BN80B4	264
53	10.0	89	222	1.8	0.8	19	3440	W 63_19	V1 P80	V 1 C V 1 F	P80	BN80B4	264
53	10.0	86	185	1.5	1.0	38	3560	W 63_38	V05 P71	V 0.5 C V 0.5 F	P71	BN71C2	264
66	12.5	67	130	2.2	1.3	10	3240	W 63_10	V1 P80	V 1 C V 1 F	P80	BN80C6	264
67	12.7	75	192	3.6	1.5	15	4510	W 75_15	V1 P80	V 1 C V 1 F	P80	BN80B4	265
67	12.7	72	91	2.2	2.0	15	3230	W 63_15	V05 P71	V 0.5 C V 0.5 F	P80	BN80B4	264
67	12.7	72	182	2.2	1.0	15	3230	W 63_15	V1 P80	V 1 C V 1 F	P80	BN80B4	264
67	12.7	70	154	1.8	1.2	30	3330	W 63_30	V05 P71	V 0.5 C V 0.5 F	P71	BN71C2	264
83	15.8	59	76	2.5	2.2	12	3040	W 63_12	V05 P71	V 0.5 C V 0.5 F	P80	BN80B4	264
83	15.8	59	134	2.2	1.4	24	3120	W 63_24	V05 P71	V 0.5 C V 0.5 F	P71	BN71C2	264
95	17.9	49	94	2.7	1.5	7	2920	W 63_7	V1 P80	V 1 C V 1 F	P80	BN80C6	264
100	19.0	52	134	4.8	2.0	10	4100	W 75_10	V1 P80	V 1 C V 1 F	P80	BN80B4	265
100	19.0	50	65	3.0	2.5	10	2890	W 63_10	V05 P71	V 0.5 C V 0.5 F	P80	BN80B4	264
100	19.0	50	130	3.0	1.3	10	2890	W 63_10	V1 P80	V 1 C V 1 F	P80	BN80B4	264
105	20.0	48	111	2.7	1.6	19	2920	W 63_19	V05 P71	V 0.5 C V 0.5 F	P71	BN71C2	264
111	21.1	44	104	1.0	0.7	18	1750	VF 49_18	V05 P71	V 0.5 C V 0.5 F	P71	BN71C2	262-263
133	25.3	39	91	3.2	2.0	15	2720	W 63_15	V05 P71	V 0.5 C V 0.5 F	P71	BN71C2	264
143	27.1	37	47	3.6	3.0	7	2600	W 63_7	V05 P71	V 0.5 C V 0.5 F	P80	BN80B4	264

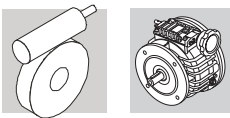

## 0.75 kW

$n_2$ min <sup>-1</sup>	$n_2'$ min <sup>-1</sup>	M <sub>2</sub> Nm	M <sub>2'</sub> Nm	S	S'	i	R <sub>n2</sub> N	V-  P(IEC)	C  F	IEC			
143	27.1	37	94	3.6	1.5	7	2600	W 63_7	V1 P80	V 1 C V 1 F	P80	BN80B4	264
143	27.1	35	84	1.4	0.9	14	1640	VF 49_14	V05 P71	V 0.5 C V 0.5 F	P71	BN71C2	262-263
200	38	26	65	4.7	2.5	10	2410	W 63_10	V05 P71	V 0.5 C V 0.5 F	P71	BN71C2	264
200	38	26	64	1.7	1.2	10	1490	VF 49_10	V05 P71	V 0.5 C V 0.5 F	P71	BN71C2	262-263
286	54	18.0	46	2.2	1.6	7	1340	VF 49_7	V05 P71	V 0.5 C V 0.5 F	P71	BN71C2	262-263

## 1.1 kW

6.6	1.3	684	1728	1.2	0.5	100	13800	VF 130_100	V2 P90	V 2 C V 2 F	P90	BN90L6	268-269
8.3	1.6	586	1485	1.8	0.8	80	13800	VF 130_80	V2 P90	V 2 C V 2 F	P90	BN90L6	268-269
10.0	1.9	531	1296	1.5	0.7	100	13200	VF 130_100	V2 P90	V 2 C V 2 F	P90	BN90S4	268-269
10.4	2.0	499	1229	1.1	0.5	64	8000	W 110_64	V2 P90	V 2 C V 2 F	P90	BN90L6	267
10.6	2.2	457	564	1.4	1.3	56	8000	W 110_56	— P80	— V 1 F	P90	BN90L6	267
11.8	2.2	457	1165	2.5	1.0	56	13800	VF 130_56	V2 P90	V 2 C V 2 F	P90	BN90L6	268-269
12.5	2.4	461	1114	2.1	1.0	80	13200	VF 130_80	V2 P90	V 2 C V 2 F	P90	BN90S4	268-269
12.5	2.4	439	1075	1.1	0.5	80	8000	W 110_80	V2 P90	V 2 C V 2 F	P90	BN90S4	267
14.4	2.7	392	972	1.6	0.7	46	8000	W 110_46	V2 P90	V 2 C V 2 F	P90	BN90L6	267
15.6	3.0	392	952	2.7	1.3	64	13200	VF 130_64	V2 P90	V 2 C V 2 F	P90	BN90S4	268-269
15.6	3.0	374	922	1.5	0.7	64	8000	W 110_64	V2 P90	V 2 C V 2 F	P90	BN90S4	267
16.1	3.4	336	538	1.0	0.7	56	7000	W 86_56	V1 P80	V 1 C V 1 F	P90	BN90S4	266
16.6	3.1	341	845	1.0	0.5	40	7000	W 86_40	V2 P90	V 2 C V 2 F	P90	BN90L6	266
17.9	3.4	343	847	1.9	0.8	56	8000	W 110_56	V2 P90	V 2 C V 2 F	P90	BN90S4	267
17.9	3.4	353	874	3.1	1.4	56	13200	VF 130_56	V2 P90	V 2 C V 2 F	P90	BN90S4	268-269
19.6	4.1	289	464	1.3	0.9	46	7000	W 86_46	V1 P80	V 1 C V 1 F	P90	BN90S4	266
20.0	3.8	302	612	1.4	0.9	100	8000	W 110_100	— P80	— V 1 F	P80	BN80B2	267
21.7	4.1	302	751	3.8	1.8	46	7700	VF 130_46	V2 P90	V 2 C V 2 F	P90	BN90S4	268-269
21.7	4.1	294	729	2.2	1.0	46	8000	W 110_46	V2 P90	V 2 C V 2 F	P90	BN90S4	267
21.7	4.1	286	696	1.3	0.6	46	7000	W 86_46	V2 P90	V 2 C V 2 F	P90	BN90S4	266
22.5	4.8	258	422	1.4	0.9	40	7000	W 86_40	V1 P80	V 1 C V 1 F	P90	BN90S4	266
22.5	4.8	248	403	1.1	0.8	40	5480	W 75_40	V1 P80	V 1 C V 1 F	P90	BN90S4	265
25.0	4.8	263	653	2.7	1.2	40	8000	W 110_40	V2 P90	V 2 C V 2 F	P90	BN90S4	267
25.0	4.8	256	538	1.6	1.0	80	8000	W 110_80	— P80	— V 1 F	P80	BN80B2	267
25.0	4.8	256	634	1.4	0.6	40	7000	W 86_40	V2 P90	V 2 C V 2 F	P90	BN90S4	266

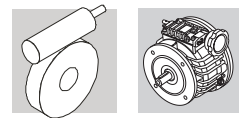

# 1.1 kW

$n_2$ min <sup>-1</sup>	$n_2'$ min <sup>-1</sup>	M <sub>2</sub> Nm	M <sub>2'</sub> Nm	S	S'	i	R <sub>n2</sub> N	V-  P(IEC)	C  F	IEC			
28.8	5.4	221	552	1.6	0.7	23	7000	W 86_23	V2 P90	V 2 C V 2 F	P90	BN90L6	266
30	6.3	199	322	2.0	1.4	30	7000	W 86_30	V1 P80	V 1 C V 1 F	P90	BN90S4	266
30	6.3	202	331	1.4	1.0	30	5110	W 75_30	V1 P80	V 1 C V 1 F	P90	BN90S4	265
31	5.9	210	297	1.2	1.1	64	7000	W 86_64	— P71	— V 0.5 F	P80	BN80B2	266
33	6.3	192	493	1.4	0.6	20	5100	W 75_20	V2 P90	V 2 C V 2 F	P90	BN90L6	265
33	6.3	200	504	3.8	1.6	30	8000	W 110_30	V2 P90	V 2 C V 2 F	P90	BN90S4	267
33	6.3	197	482	2.0	0.9	30	7000	W 86_30	V2 P90	V 2 C V 2 F	P90	BN90S4	266
36	6.8	192	423	2.8	1.7	56	8000	W 110_56	— P80	— V 1 F	P80	BN80B2	267
36	6.8	189	403	1.4	0.9	56	7000	W 86_56	V1 P80	V 1 C V 1 F	P80	BN80B2	266
36	7.6	175	292	1.5	1.0	25	4870	W 75_25	V1 P80	V 1 C V 1 F	P90	BN90S4	265
38	7.9	164	269	1.0	0.7	24	3270	W 63_24	V1 P80	V 1 C V 1 F	P90	BN90S4	264
43	8.3	168	425	3.5	1.5	23	8000	W 110_23	V2 P90	V 2 C V 2 F	P90	BN90S4	267
43	8.3	166	414	2.1	0.9	23	7000	W 86_23	V2 P90	V 2 C V 2 F	P90	BN90S4	266
43	8.3	159	348	1.9	1.2	46	7000	W 86_46	V1 P80	V 1 C V 1 F	P80	BN80B2	266
44	8.3	148	374	2.4	1.0	15	7000	W 86_15	V2 P90	V 2 C V 2 F	P90	BN90L6	266
44	8.3	149	384	1.8	0.8	15	4750	W 75_15	V2 P90	V 2 C V 2 F	P90	BN90L6	265
45	9.5	147	246	2.3	1.5	20	7000	W 86_20	V1 P80	V 1 C V 1 F	P90	BN90S4	266
45	9.5	146	246	1.9	1.2	20	4600	W 75_20	V1 P80	V 1 C V 1 F	P90	BN90S4	265
47	10.0	135	222	1.2	0.8	19	3110	W 63_19	V1 P80	V 1 C V 1 F	P90	BN90S4	264
50	9.5	148	379	4.2	1.8	20	8000	W 110_20	V2 P90	V 2 C V 2 F	P90	BN90S4	267
50	9.5	146	370	2.4	1.0	20	7000	W 86_20	V2 P90	V 2 C V 2 F	P90	BN90S4	266
50	9.5	144	370	1.9	0.8	20	4600	W 75_20	V2 P90	V 2 C V 2 F	P90	BN90S4	265
50	9.5	139	302	1.6	1.0	40	4770	W 75_40	V1 P80	V 1 C V 1 F	P80	BN80B2	265
60	12.7	113	192	2.4	1.5	15	4500	W 75_15	V1 P80	V 1 C V 1 F	P90	BN90S4	265
60	12.7	109	182	1.5	1.0	15	2960	W 63_15	V1 P80	V 1 C V 1 F	P90	BN90S4	264
66	12.5	103	269	2.4	1.0	10	4240	W 75_10	V2 P90	V 2 C V 2 F	P90	BN90L6	265
67	12.7	112	288	5.8	2.5	15	8000	W 110_15	V2 P90	V 2 C V 2 F	P90	BN90S4	267
67	12.7	111	281	3.2	1.4	15	7000	W 86_15	V2 P90	V 2 C V 2 F	P90	BN90S4	266
67	12.7	112	288	2.4	1.0	15	4260	W 75_15	V2 P90	V 2 C V 2 F	P90	BN90S4	265
67	12.7	105	230	1.2	0.8	30	2960	W 63_30	V1 P80	V 1 C V 1 F	P80	BN80B2	264
75	15.8	90	152	1.7	1.1	12	2810	W 63_12	V1 P80	V 1 C V 1 F	P90	BN90S4	264
80	15.2	93	219	2.4	1.3	25	4180	W 75_25	V1 P80	V 1 C V 1 F	P80	BN80B2	265
83	15.8	89	202	1.5	0.9	24	2930	W 63_24	V1 P80	V 1 C V 1 F	P80	BN80B2	264

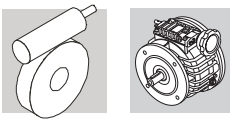

## 1.1 kW

n <sub>2</sub> min <sup>-1</sup>	n <sub>2</sub> ' min <sup>-1</sup>	M <sub>2</sub> Nm	M <sub>2</sub> ' Nm	S	S'	i	R <sub>n2</sub> N	V- P(IEC)	C F				
87	16.5	88	207	3.2	1.8	23	7000	W 86_23	V1 P80	V 1 C V 1 F	P80	BN80B2	266
90	19.0	78	134	3.2	2.0	10	3790	W 75_10	V1 P80	V 1 C V 1 F	P90	BN90S4	265
90	19.0	76	130	2.0	1.3	10	6780	W 63_10	V1 P80	V 1 C V 1 F	P90	BN90S4	264
100	19.0	77	190	6.6	3.6	20	8000	W 110_20	— P80	— V 1 F	P80	BN80B2	267
100	19.0	77	202	3.2	1.4	10	3790	W 75_10	V2 P90	V 2 C V 2 F	P90	BN90S4	265
100	19.0	77	185	2.9	1.6	20	3910	W 75_20	V1 P80	V 1 C V 1 F	P80	BN80B2	265
105	20.0	72	166	1.8	1.1	19	2760	W 63_19	V1 P80	V 1 C V 1 F	P80	BN80B2	264
129	27.1	56	96	3.7	2.3	7	3400	W 75_7	V1 P80	V 1 C V 1 F	P90	BN90S4	265
129	27.1	55	94	2.3	1.5	7	2440	W 63_7	V1 P80	V 1 C V 1 F	P90	BN90S4	264
133	25.3	59	144	3.8	2.0	15	3600	W 75_15	V1 P80	V 1 C V 1 F	P80	BN80B2	265
133	25.3	58	137	2.2	1.3	15	2590	W 63_15	V1 P80	V 1 C V 1 F	P80	BN80B2	264
143	27.1	55	144	9.7	4.1	7	8000	W 110_7	V2 P90	V 2 C V 2 F	P90	BN90S4	267
143	27.1	55	144	3.7	1.6	7	3400	W 75_7	V2 P90	V 2 C V 2 F	P90	BN90S4	265
200	38	40	97	3.2	1.7	10	2310	W 63_10	V1 P80	V 1 C V 1 F	P80	BN80B2	264
286	54	28	71	3.7	2.0	7	2080	W 63_7	V1 P80	V 1 C V 1 F	P80	BN80B2	264

## 1.5 kW

8.3	1.6	781	1624	1.3	0.7	80	13800	VF 130_80	V2 P90	V 2 C V 2 F	P90	BN100LA6R	268-269
10.0	1.9	708	1728	1.1	0.5	100	13200	VF 130_100	V2 P90	V 2 C V 2 F	P90	BN90LA4	268-269
10.4	2.0	666	1389	1.7	0.9	64	13800	VF 130_64	V2 P90	V 2 C V 2 F	P90	BN100LA6R	268-269
11.8	2.2	609	1235	1.1	0.6	56	8000	W 110_56	V2 P90	V 2 C V 2 F	P90	BN100LA6R	267
12.5	2.4	614	1485	1.5	0.8	80	13200	VF 130_80	V2 P90	V 2 C V 2 F	P90	BN90LA4	268-269
14.4	2.7	523	1063	1.2	0.7	46	8000	W 110_46	V2 P90	V 2 C V 2 F	P90	BN100LA6R	267
15.6	3.0	522	1270	2.0	0.9	64	13200	VF 130_64	V2 P90	V 2 C V 2 F	P90	BN90LA4	268-269
16.6	3.1	467	952	1.5	0.8	40	8000	W 110_40	V2 P90	V 2 C V 2 F	P90	BN100LA6R	267
17.9	3.4	457	1129	1.4	0.6	56	8000	W 110_56	V2 P90	V 2 C V 2 F	P90	BN90LA4	267
17.9	3.4	470	1165	2.3	1.0	56	13200	VF 130_56	V2 P90	V 2 C V 2 F	P90	BN90LA4	268-269
19.6	4.1	381	464	1.0	0.9	46	7000	W 86_46	V1 P80	V 1 C V 1 F	P90	BN90LA4	266
21.7	4.1	403	1001	2.9	1.3	46	13200	VF 130_46	V2 P90	V 2 C V 2 F	P90	BN90LA4	268-269
21.7	4.1	392	972	1.6	0.7	46	8000	W 110_46	V2 P90	V 2 C V 2 F	P90	BN90LA4	267
22.1	4.2	350	704	1.1	0.6	30	7000	W 86_30	V2 P90	V 2 C V 2 F	P90	BN100LA6R	266
22.5	4.8	341	422	1.0	0.9	40	7000	W 86_40	V1 P80	V 1 C V 1 F	P90	BN90LA4	266
25.0	4.8	350	870	3.4	1.6	40	13200	VF 130_40	—	—	P90	BN90LA4	268-269

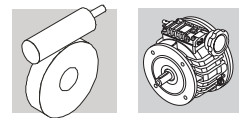





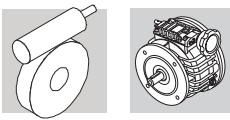

# 1.5 kW

$n_2$ min <sup>-1</sup>	$n_2'$ min <sup>-1</sup>	$M_2$ Nm	$M_2'$ Nm	S	S'	i	$R_{n2}$ N						
25.0	4.8	350	870	2.1	0.9	40	8000	W 110_40	V2 P90	V 2 C V 2 F	P90	BN90LA4	267
25.0	4.8	341	845	1.0	0.5	40	7000	W 86_40	V2 P90	V 2 C V 2 F	P90	BN90LA4	266
28.8	5.4	298	620	1.9	1.0	23	8000	W 110_23	V2 P90	V 2 C V 2 F	P90	BN100LA6R	267
28.8	5.4	294	604	1.2	0.6	23	7000	W 86_23	V2 P90	V 2 C V 2 F	P90	BN100LA6R	266
30	6.3	263	322	1.5	1.4	30	7000	W 86_30	V1 P80	V 1 C V 1 F	P90	BN90LA4	266
30	6.3	266	331	1.1	1.0	30	4710	W 75_30	V1 P80	V 1 C V 1 F	P90	BN90LA4	265
31	5.9	284	614	1.7	1.0	64	8000	W 110_64	— P80	— V 1 F	P80	BN80C2	267
33	6.3	277	691	4.5	2.2	30	13200	VF 130_30	V2 —	V 2 C —	P90	BN90LA4	268-269
33	6.3	266	672	2.8	1.2	30	8000	W 110_30	V2 P90	V 2 C V 2 F	P90	BN90LA4	267
33	6.3	263	643	1.5	0.7	30	7000	W 86_30	V2 P90	V 2 C V 2 F	P90	BN90LA4	266
36	6.8	255	564	2.1	1.3	56	8000	W 110_56	— P80	— V 1 F	P80	BN80C2	267
36	7.6	231	292	1.2	1.0	25	4530	W 75_25	V1 P80	V 1 C V 1 F	P90	BN90LA4	265
39	8.3	221	276	1.6	1.4	23	7000	W 86_23	V1 P80	V 1 C V 1 F	P90	BN90LA4	266
43	8.3	224	567	2.6	1.1	23	8000	W 110_23	V2 P90	V 2 C V 2 F	P90	BN90LA4	267
43	8.3	218	486	2.5	1.5	46	8000	W 110_46	— P80	— V 1 F	P80	BN80C2	267
43	8.3	221	552	1.6	0.7	23	7000	W 86_23	V2 P90	V 2 C V 2 F	P90	BN90LA4	266
43	8.3	213	464	1.4	0.9	46	7000	W 86_46	V1 P80	V 1 C V 1 F	P80	BN80C2	266
45	9.5	194	246	1.8	1.5	20	7000	W 86_20	V1 P80	V 1 C V 1 F	P90	BN90LA4	266
45	9.5	192	246	1.4	1.2	20	4300	W 75_20	V1 P80	V 1 C V 1 F	P90	BN90LA4	265
50	9.5	197	506	3.1	1.3	20	8000	W 110_20	V2 P90	V 2 C V 2 F	P90	BN90LA4	267
50	9.5	194	493	1.8	0.8	20	7000	W 86_20	V2 P90	V 2 C V 2 F	P90	BN90LA4	266
50	9.5	190	422	1.6	0.9	40	7000	W 86_40	V1 P80	V 1 C V 1 F	P80	BN80C2	266
50	9.5	192	493	1.4	0.6	20	4300	W 75_20	V2 P90	V 2 C V 2 F	P90	BN90LA4	265
60	12.7	148	187	2.4	2.1	15	7000	W 86_15	V1 P80	V 1 C V 1 F	P90	BN90LA4	266
60	12.7	149	192	1.8	1.5	15	4020	W 75_15	V1 P80	V 1 C V 1 F	P90	BN90LA4	265
60	12.7	144	182	1.1	1.0	15	2690	W 63_15	V1 P80	V 1 C V 1 F	P90	BN90LA4	264
67	12.7	149	384	4.3	1.8	15	2960	W 110_15	V2 P90	V 2 C V 2 F	P90	BN90LA4	267
67	12.7	148	374	2.4	1.0	15	8000	W 86_15	V2 P90	V 2 C V 2 F	P90	BN90LA4	266
67	12.7	149	384	1.8	0.8	15	7000	W 75_15	V2 P90	V 2 C V 2 F	P90	BN90LA4	265
67	12.7	146	331	1.6	1.0	30	4200	W 75_30	V1 P80	V 1 C V 1 F	P80	BN80C2	265
75	15.8	118	152	1.3	1.1	12	2570	W 63_12	V1 P80	V 1 C V 1 F	P90	BN90LA4	264
80	15.2	125	292	1.8	1.0	25	4000	W 75_25	V1 P80	V 1 C V 1 F	P80	BN80C2	265
87	16.5	117	276	2.4	1.4	23	6940	W 86_23	V1 P80	V 1 C V 1 F	P80	BN80C2	266
90	19.0	103	134	2.4	2.0	10	3600	W 75_10	V1 P80	V 1 C V 1 F	P90	BN90LA4	265
90	19.0	101	130	1.5	1.3	10	2480	W 63_10	V1 P80	V 1 C V 1 F	P90	BN90LA4	264



## 1.5 kW

$n_2$ min <sup>-1</sup>	$n_2'$ min <sup>-1</sup>	M <sub>2</sub> Nm	M <sub>2'</sub> Nm	S	S'	i	R <sub>n2</sub> N	 	 				
95	17.9	99	211	2.1	1.1	7	3590	W 75_7	V2 P90	V 2 C V 2 F	P90	BN100LA6R	265
100	19.0	103	262	3.0	1.3	10	6530	W 86_10	V2 P90	V 2 C V 2 F	P90	BN90LA4	266
100	19.0	103	269	2.4	1.0	10	3600	W 75_10	V2 P90	V 2 C V 2 F	P90	BN90LA4	265
100	19.0	103	246	2.2	1.2	20	3760	W 75_20	V1 P80	V 1 C V 1 F	P80	BN80C2	265
105	20.0	96	222	1.4	0.8	19	2590	W 63_19	V1 P80	V 1 C V 1 F	P80	BN80C2	264
129	27.1	74	96	2.8	2.3	7	2270	W 75_7	V1 P80	V 1 C V 1 F	P90	BN90LA4	265
129	27.1	73	94	1.8	1.5	7	2270	W 63_7	V1 P80	V 1 C V 1 F	P90	BN90LA4	264
133	25.3	79	192	2.8	1.5	15	3480	W 75_15	V1 P80	V 1 C V 1 F	P80	BN80C2	265
133	25.3	77	182	1.6	1.0	15	2540	W 63_15	V1 P80	V 1 C V 1 F	P80	BN80C2	264
143	27.1	74	190	3.7	1.5	7	5850	W 86_7	V2 P90	V 2 C V 2 F	P90	BN90LA4	266
143	27.1	74	193	2.8	1.2	7	3240	W 75_7	V2 P90	V 2 C V 2 F	P90	BN90LA4	265
200	38	54	134	3.8	2.0	10	3080	W 75_10	V1 P80	V 1 C V 1 F	P80	BN80C2	265
200	38	53	130	2.4	1.3	10	2210	W 63_10	V1 P80	V 1 C V 1 F	P80	BN80C2	264
286	54	38	94	2.8	1.5	7	2000	W 63_7	V1 P80	V 1 C V 1 F	P80	BN80C2	264

## 1.8 kW

10.0	1.9	826	1890	1.0	0.5	100	13200	VF 130_100	V2 P90	V 2 C V 2 F	P90	BN90LB4	268-269
12.5	2.4	717	1624	1.3	0.7	80	13200	VF 130_80	V2 P90	V 2 C V 2 F	P90	BN90LB4	268-269
15.6	3.0	609	1389	1.7	0.9	64	13200	VF 130_64	V2 P90	V 2 C V 2 F	P90	BN90LB4	268-269
17.9	3.4	533	1235	1.2	0.6	56	8000	W 110_56	V2 P90	V 2 C V 2 F	P90	BN90LB4	267
17.9	3.4	549	1274	2.0	0.9	56	13200	VF 130_56	V2 P90	V 2 C V 2 F	P90	BN90LB4	268-269
21.7	4.1	470	1095	2.4	1.2	46	13200	VF 130_46	V2 P90	V 2 C V 2 F	P90	BN90LB4	268-269
21.7	4.1	457	1063	1.4	0.7	46	8000	W 110_46	V2 P90	V 2 C V 2 F	P90	BN90LB4	267
25.0	4.8	409	952	2.9	1.5	40	13200	VF 130_40	V2 —	V 2 C —	P90	BN90LB4	268-269
25.0	4.8	409	952	1.8	0.8	40	8000	W 110_40	V2 P90	V 2 C V 2 F	P90	BN90LB4	267
33	6.3	323	756	3.9	2.0	30	13200	VF 130_30	V2 —	V 2 C —	P90	BN90LB4	268-269
33	6.3	311	735	2.4	1.1	30	8000	W 110_30	V2 P90	V 2 C V 2 F	P90	BN90LB4	267
33	6.3	307	704	1.3	0.6	30	7000	W 86_30	V2 P90	V 2 C V 2 F	P90	BN90LB4	266
43	8.3	261	620	2.2	1.0	23	8000	W 110_23	V2 P90	V 2 C V 2 F	P90	BN90LB4	267
43	8.3	258	604	1.3	0.6	23	7000	W 86_23	V2 P90	V 2 C V 2 F	P90	BN90LB4	266
50	9.5	230	553	2.7	1.2	20	8000	W 110_20	V2 P90	V 2 C V 2 F	P90	BN90LB4	267
50	9.5	227	539	1.5	0.7	20	7000	W 86_20	V2 P90	V 2 C V 2 F	P90	BN90LB4	266
67	12.7	174	420	3.7	1.7	15	8000	W 110_15	V2 P90	V 2 C V 2 F	P90	BN90LB4	267

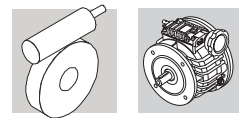

## 1.8 kW

$n_2$ min <sup>-1</sup>	$n_2'$ min <sup>-1</sup>	M <sub>2</sub> Nm	M <sub>2'</sub> Nm	S	S'	i	R <sub>n2</sub> N	V-  P(IEC)	C  F	IEC			
67	12.7	172	410	2.1	1.0	15	7000	W 86_15	V2 P90	V 2 C V 2 F	P90	BN90LB4	266
67	12.7	174	420	1.5	0.7	15	3860	W 75_15	V2 P90	V 2 C V 2 F	P90	BN90LB4	265
100	19.0	120	287	2.6	1.2	10	6420	W 86_10	V2 P90	V 2 C V 2 F	P90	BN90LB4	266
100	19.0	120	294	2.1	0.9	10	3470	W 75_10	V2 P90	V 2 C V 2 F	P90	BN90LB4	265
143	27.1	86	208	3.1	1.4	7	5760	W 86_7	V2 P90	V 2 C V 2 F	P90	BN90LB4	266
143	27.1	86	211	2.4	1.1	7	3130	W 75_7	V2 P90	V 2 C V 2 F	P90	BN90LB4	265

## 2.2 kW

6.6	1.3	1440	3136	1.4	0.7	100	19500	VF 185_100	V3 P100	V 3 C V 3 F	P112	BN112M6	272-273
8.3	1.6	1229	2688	2.1	1.0	80	19500	VF 185_80	V3 P100	V 3 C V 3 F	P112	BN112M6	272-273
8.3	1.6	1210	2643	1.2	0.6	80	16000	VF 150_80	V3 P100	V 3 C V 3 F	P112	BN112M6	270-271
10.0	1.9	976	2200	1.2	0.6	100	15000	VF 150_100	V3 P100	V 3 C V 3 F	P100	BN100LA4	270-271
10.4	2.0	998	2222	1.1	0.5	64	13800	VF 130_64	V3 P100	V 3 C V 3 F	P112	BN112M6	268-269
11.8	2.2	927	2070	1.8	0.8	56	16000	VF 150_56	V3 P100	V 3 C V 3 F	P112	BN112M6	270-271
11.8	2.2	914	2038	1.2	0.6	56	13800	VF 130_56	V3 P100	V 3 C V 3 F	P112	BN112M6	268-269
12.5	2.4	832	1888	1.6	0.8	80	15500	VF 150_80	V3 P100	V 3 C V 3 F	P100	BN100LA4	270-271
12.5	2.4	819	1856	1.2	0.6	80	13200	VF 130_80	V3 P100	V 3 C V 3 F	P100	BN100LA4	268-269
14.4	2.7	795	1777	2.4	1.1	46	16000	VF 150_46	V3 P100	V 3 C V 3 F	P112	BN112M6	270-271
14.4	2.7	784	1752	1.6	0.8	46	13800	VF 130_46	V3 P100	V 3 C V 3 F	P112	BN112M6	268-269
15.6	3.0	707	1613	2.1	1.1	64	15500	VF 150_64	V3 P100	V 3 C V 3 F	P100	BN100LA4	270-271
15.6	3.0	696	1587	1.5	0.8	64	13200	VF 130_64	V3 P100	V 3 C V 3 F	P100	BN100LA4	268-269
16.6	3.1	701	1523	1.0	0.5	40	8000	W 110_40	— P100	— V 3 F	P112	BN112M6	267
17.9	3.4	636	1478	2.4	1.2	56	15500	VF 150_56	V3 P100	V 3 C V 3 F	P100	BN100LA4	270-271
17.9	3.4	627	1456	1.7	0.8	56	13200	VF 130_56	V3 P100	V 3 C V 3 F	P100	BN100LA4	268-269
21.7	4.1	545	1270	3.2	1.6	46	15500	VF 150_46	V3 P100	V 3 C V 3 F	P100	BN100LA4	270-271
21.7	4.1	537	1251	2.1	1.1	46	13200	VF 130_46	V3 P100	V 3 C V 3 F	P100	BN100LA4	268-269
21.7	4.1	523	1214	1.2	0.6	46	8000	W 110_46	— P100	— V 3 F	P100	BN100LA4	267
25.0	4.8	474	1104	3.7	1.8	40	15500	VF 150_40	V3 P100	V 3 C V 3 F	P100	BN100LA4	270-271
25.0	4.8	467	1088	2.6	1.3	40	13200	VF 130_40	V3 P100	V 3 C V 3 F	P100	BN100LA4	268-269
25.0	4.8	467	1088	1.5	0.7	40	8000	W 110_40	— P100	— V 3 F	P100	BN100LA4	267
28.8	5.4	436	992	2.7	1.3	23	13800	VF 130_23	V3 P100	V 3 C V 3 F	P112	BN112M6	268-269
28.8	5.4	447	992	1.3	0.6	23	8000	W 110_23	— P100	— V 3 F	P112	BN112M6	267

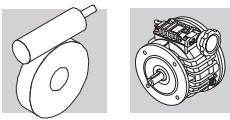

## 2.2 kW

$n_2$ min <sup>-1</sup>	$n_2'$ min <sup>-1</sup>	M <sub>2</sub> Nm	M <sub>2'</sub> Nm	S	S'	i	R <sub>n2</sub> N	V-	C				
33	6.3	370	876	4.3	2.2	30	15500	VF 150_30	V3 P100	V 3 C V 3 F	P100	BN100LA4	270-271
33	6.3	370	864	3.4	1.7	30	13200	VF 130_30	V3 P100	V 3 C V 3 F	P100	BN100LA4	268-269
33	6.3	355	840	2.1	1.0	30	8000	W 110_30	— P100	— V 3 F	P100	BN100LA4	267
43	8.3	298	708	3.5	1.8	23	13200	VF 130_23	V3 P100	V 3 C V 3 F	P100	BN100LA4	268-269
43	8.3	298	708	1.9	0.9	23	8000	W 110_23	— P100	— V 3 F	P100	BN100LA4	267
50	9.5	262	632	4.0	2.1	20	13200	VF 130_20	V3 P100	V 3 C V 3 F	P100	BN100LA4	268-269
50	9.5	262	632	2.3	1.1	20	8000	W 110_20	— P100	— V 3 F	P100	BN100LA4	267
67	12.7	199	480	3.2	1.5	15	8000	W 110_15	— P100	— V 3 F	P100	BN100LA4	267
95	17.9	148	337	3.7	1.8	7	8000	W 110_7	— P100	— V 3 F	P112	BN112M6	267
95	17.9	148	333	1.8	0.9	7	6250	W 86_7	— P100	— V 3 F	P112	BN112M6	266
100	19.0	138	336	4.3	1.9	10	8000	W 110_10	— P100	— V 3 F	P100	BN100LA4	267
143	27.1	99	241	5.5	2.5	7	8000	W 110_7	— P100	— V 3 F	P100	BN100LA4	267

## 3.0 kW

10.0	1.9	1488	3136	1.3	0.7	100	19000	VF 185_100	— P100	— V 3 F	P100	BN100LB4	272-273
12.5	2.4	1267	2688	1.9	1.0	80	19000	VF 185_80	— P100	— V 3 F	P100	BN100LB4	272-273
12.5	2.4	1248	2643	1.1	0.6	80	15500	VF 150_80	V3 P100	V 3 C V 3 F	P100	BN100LB4	270-271
15.6	3.0	1060	2258	1.4	0.8	64	15500	VF 150_64	V3 P100	V 3 C V 3 F	P100	BN100LB4	270-271
15.6	3.0	1044	2222	1.0	0.5	64	13200	VF 130_64	V3 P100	V 3 C V 3 F	P100	BN100LB4	268-269
16.7	3.2	1022	2218	2.5	1.4	60	19000	VF 185_60	— P100	— V 3 F	P100	BN100LB4	272-273
17.9	3.4	954	2070	1.6	0.8	56	15500	VF 150_56	V3 P100	V 3 C V 3 F	P100	BN100LB4	270-271
17.9	3.4	941	2038	1.1	0.6	56	13200	VF 130_56	V3 P100	V 3 C V 3 F	P100	BN100LB4	268-269
20.0	3.8	876	1904	3.3	1.7	50	19000	VF 185_50	— P100	— V 3 F	P100	BN100LB4	272-273
21.7	4.1	817	1777	2.1	1.1	46	15500	VF 150_46	V3 P100	V 3 C V 3 F	P100	BN100LB4	270-271
21.7	4.1	806	1752	1.4	0.8	46	13200	VF 130_46	V3 P100	V 3 C V 3 F	P100	BN100LB4	268-269
25.0	4.8	710	1546	2.5	1.3	40	15500	VF 150_40	V3 P100	V 3 C V 3 F	P100	BN100LB4	270-271
25.0	4.8	701	1523	1.7	0.9	40	13200	VF 130_40	V3 P100	V 3 C V 3 F	P100	BN100LB4	268-269
33	6.3	554	1226	2.9	1.6	30	15500	VF 150_30	V3 P100	V 3 C V 3 F	P100	BN100LB4	270-271
33	6.3	554	1210	2.3	1.2	30	13200	VF 130_30	V3 P100	V 3 C V 3 F	P100	BN100LB4	268-269
33	6.3	533	1176	1.4	0.7	30	8000	W 110_30	— P100	— V 3 F	P100	BN100LB4	267
43	8.3	453	1005	3.3	1.8	23	15500	VF 150_23	V3 P100	V 3 C V 3 F	P100	BN100LB4	270-271
43	8.3	447	992	2.3	1.3	23	13200	VF 130_23	V3 P100	V 3 C V 3 F	P100	BN100LB4	268-269



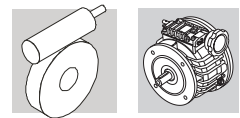

## 3.0 kW

$n_2$ min <sup>-1</sup>	$n_2'$ min <sup>-1</sup>	M <sub>2</sub> Nm	M <sub>2'</sub> Nm	S	S'	i	R <sub>n2</sub> N	V	P(IEC)	C	F		
43	8.3	447	992	1.3	0.6	23	8000	W 110_23	— P100	— V 3 F	P100	BN100LB4	267
50	9.5	394	885	2.7	1.5	20	13200	VF 130_20	V3 P100	V 3 C V 3 F	P100	BN100LB4	268-269
50	9.5	394	885	1.6	0.8	20	8000	W 110_20	— P100	— V 3 F	P100	BN100LB4	267
67	12.7	299	672	2.2	1.1	15	8000	W 110_15	— P100	— V 3 F	P100	BN100LB4	267
67	12.7	302	680	3.6	2.0	15	13130	VF 130_15	V3 P100	V 3 C V 3 F	P100	BN100LB4	268-269
100	19.0	206	470	2.9	1.4	10	8000	W 110_10	— P100	— V 3 F	P100	BN100LB4	267
143	27.1	148	337	3.7	1.8	7	8000	W 110_7	— P100	— V 3 F	P100	BN100LB4	267

## 4.0 kW

6.6	1.3	2666	4988	2.0	1.0	100	52000	VF 250_100	— P132	— V 10 F	P132	BN132MA6	275
6.6	1.3	2537	4816	1.3	0.7	100	34500	VF 210_100	— P132	— V 10 F	P132	BN132MA6	274
8.3	1.6	2167	4128	1.7	0.9	80	34500	VF 210_80	— P132	— V 10 F	P132	BN132MA6	274
8.3	1.6	2202	4128	1.2	0.7	80	19500	VF 185_80	— P132	— V 10 F	P132	BN132MA6	272-273
10.0	1.9	1984	4032	1.0	0.6	100	19000	VF 185_100	— P100	— V 5.5 F	P112	BN112M4	272-273
11.1	2.1	1754	3354	2.3	1.3	60	34500	VF 210_60	— P132	— V 10 F	P132	BN132MA6	274
11.1	2.1	1780	3406	1.6	0.9	60	19500	VF 185_60	— P132	— V 10 F	P132	BN132MA6	272-273
12.5	2.4	1690	3456	1.4	0.8	80	19000	VF 185_80	— P100	— V 5.5 F	P112	BN112M4	272-273
13.3	2.5	1527	2924	2.8	1.5	50	34500	VF 210_50	— P132	— V 10 F	P132	BN132MA6	274
13.3	2.5	1527	2924	2.0	1.1	50	19500	VF 185_50	— P132	— V 10 F	P132	BN132MA6	272-273
14.4	2.7	1424	2730	1.3	0.7	46	16000	VF 150_46	— P132	— V 10 F	P132	BN132MA6	270-271
15.6	3.0	1413	2903	1.0	0.6	64	15500	VF 150_64	V55 P112	V 5.5 C V 5.5 F	P112	BN112M4	270-271
16.7	3.2	1363	2851	1.9	1.1	60	19000	VF 185_60	— P100	— V 5.5 F	P112	BN112M4	272-273
17.9	3.4	1272	2661	1.2	0.7	56	15500	VF 150_56	V55 P112	V 5.5 C V 5.5 F	P112	BN112M4	270-271
20.0	3.8	1168	2448	2.5	1.3	50	19000	VF 185_50	V55 P112	V 5.5 C V 5.5 F	P112	BN112M4	272-273
21.7	4.1	1089	2285	1.6	0.9	46	15500	VF 150_46	V55 P112	V 5.5 C V 5.5 F	P112	BN112M4	270-271
21.7	4.1	1075	2252	1.1	0.6	46	13200	VF 130_46	V55 P112	V 5.5 C V 5.5 F	P112	BN112M4	268-269
25.0	4.8	947	1987	1.8	1.0	40	15500	VF 150_40	V55 P112	V 5.5 C V 5.5 F	P112	BN112M4	270-271
25.0	4.8	934	1958	1.3	0.7	40	13200	VF 130_40	V55 P112	V 5.5 C V 5.5 F	P112	BN112M4	268-269
28.8	5.4	781	1523	1.5	0.9	23	13800	VF 130_23	— P132	— V 10 F	P132	BN132MA6	268-269
33	6.3	739	1577	2.2	1.2	30	15500	VF 150_30	V55 P112	V 5.5 C V 5.5 F	P112	BN112M4	270-271
33	6.3	739	1555	1.7	1.0	30	13200	VF 130_30	V55 P112	V 5.5 C V 5.5 F	P112	BN112M4	268-269

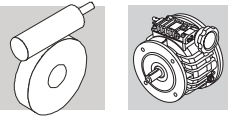

## 4.0 kW





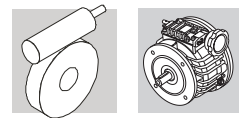

$n_2$ min <sup>-1</sup>	$n_2'$ min <sup>-1</sup>	$M_2$ Nm	$M_2'$ Nm	S	S'	i	R <sub>n2</sub> N	V	P(IEC)	C	F		
33	6.3	710	1512	1.1	0.5	30	8000	W 110_30	— P112	— V 5.5 F	P112	BN112M4	267
43	8.3	604	1292	2.5	1.4	23	15500	VF 150_23	V55 P112	V 5.5 C V 5.5 F	P112	BN112M4	270-271
43	8.3	596	1275	1.8	1.0	23	13200	VF 130_23	V55 P112	V 5.5 C V 5.5 F	P112	BN112M4	268-269
43	8.3	596	1275	1.0	0.5	23	8000	W 110_23	— P112	— V 5.5 F	P112	BN112M4	267
50	9.5	531	1152	2.8	1.6	20	15500	VF 150_20	V55 —	V 5.5 C —	P112	BN112M4	270-271
50	9.5	525	1138	2.0	1.2	20	13200	VF 130_20	V55 P112	V 5.5 C V 5.5 F	P112	BN112M4	268-269
67	12.7	398	864	1.6	0.8	15	8000	W 110_15	— P112	— V 5.5 F	P112	BN112M4	267
67	12.7	408	896	3.3	1.9	15	14420	VF 150_15	V55 —	V 5.5 C —	P112	BN112M4	270-271
67	12.7	403	875	2.7	1.5	15	12720	VF 130_15	V55 P112	V 5.5 C V 5.5 F	P112	BN112M4	268-269
95	17.9	265	518	3.5	1.9	7	11350	VF 130_7	— P132	— V 10 F	P132	BN132MA6	268-269
100	19.0	278	612	4.3	2.5	10	12770	VF 150_10	V55 —	V 5.5 C —	P112	BN112M4	270-271
100	19.0	278	605	3.2	1.8	10	11290	VF 130_10	V55 P112	V 5.5 C V 5.5 F	P112	BN112M4	268-269
100	19.0	275	605	2.1	1.1	10	8000	W 110_10	— P112	— V 5.5 F	P112	BN112M4	267
143	27.1	199	438	5.8	3.2	7	11370	VF 150_7	V55 P112	V 5.5 C V 5.5 F	P112	BN112M4	270-271
143	27.1	197	433	2.7	1.4	7	7810	W 110_7	— P100	— V 5.5 F	P112	BN112M4	267

## 5.5 kW

8.3	1.6	3175	5568	1.1	0.7	80	34500	VF 210_80	— P132	— V 10 F	P132	BN132MB6	274
10.0	1.9	2623	4816	1.1	0.7	100	33000	VF 210_100	— P132	— V 10 F	P132	BN132S4	274
11.1	2.1	2570	4524	1.6	1.0	60	34500	VF 210_60	— P132	— V 10 F	P132	BN132MB6	274
11.1	2.1	2608	4594	1.1	0.7	60	33000	VF 185_60	— P132	— V 10 F	P132	BN132MB6	272-273
12.5	2.4	2236	4128	1.5	0.9	80	33000	VF 210_80	— P132	— V 10 F	P132	BN132S4	274
12.5	2.4	2270	4128	1.1	0.7	80	19000	VF 185_80	— P132	— V 10 F	P132	BN132S4	272-273
16.6	3.1	1814	3202	1.0	0.6	40	16000	VF 150_40	— P132	— V 10 F	P132	BN132MB6	270-271
16.7	3.2	1806	3354	2.1	1.3	60	33000	VF 210_60	— P132	— V 10 F	P132	BN132S4	274
16.7	3.2	1832	3406	1.4	0.9	60	19000	VF 185_60	— P132	— V 10 F	P132	BN132S4	272-273
20.0	3.8	1548	2924	2.6	1.5	50	33000	VF 210_50	— P132	— V 10 F	P132	BN132S4	274
20.0	3.8	1570	2924	1.8	1.1	50	19000	VF 185_50	— P132	— V 10 F	P132	BN132S4	272-273
21.7	4.1	1464	2730	1.2	0.7	46	15500	VF 150_46	— P132	— V 10 F	P132	BN132S4	270-271
22.1	4.2	1493	2680	1.7	1.0	30	19500	VF 185_30	— P132	— V 10 F	P132	BN132MB6	272-273
22.1	4.2	1436	2540	1.2	0.8	30	16000	VF 150_30	— P132	— V 10 F	P132	BN132MB6	270-271
25.0	4.8	1307	2442	2.4	1.5	40	19000	VF 185_40	— P132	— V 10 F	P132	BN132S4	272-273
25.0	4.8	1273	2374	1.4	0.8	40	15500	VF 150_40	— P132	— V 10 F	P132	BN132S4	270-271



## 5.5 kW

$n_2$ min <sup>-1</sup>	$n_2'$ min <sup>-1</sup>	$M_2$ Nm	$M_2'$ Nm	S	S'	i	$R_{n2}$ N	 	 				
28.8	5.4	1159	2081	1.4	0.9	23	16000	VF 150_23	— P132	— V 10 F	P132	BN132MB6	270-271
28.8	5.4	1145	2054	1.0	0.6	23	13800	VF 130_23	— P132	— V 10 F	P132	BN132MB6	268-269
33	6.3	1045	1987	2.3	1.4	30	19000	VF 185_30	— P132	— V 10 F	P132	BN132S4	272-273
33	6.3	993	1883	1.6	1.0	30	15500	VF 150_30	— P132	— V 10 F	P132	BN132S4	270-271
33	6.3	993	1858	1.3	0.8	30	13200	VF 130_30	— P132	— V 10 F	P132	BN132S4	268-269
43	8.3	811	1543	1.8	1.2	23	15500	VF 150_23	— P132	— V 10 F	P132	BN132S4	270-271
43	8.3	801	1523	1.3	0.9	23	13200	VF 130_23	— P132	— V 10 F	P132	BN132S4	268-269
50	9.5	714	1376	2.1	1.4	20	15120	VF 150_20	— P132	— V 10 F	P132	BN132S4	270-271
50	9.5	705	1359	1.5	1.0	20	13080	VF 130_20	— P132	— V 10 F	P132	BN132S4	268-269
66	12.5	542	974	1.8	1.1	10	11900	VF 130_10	— P132	— V 10 F	P132	BN132MB6	268-269
67	12.7	548	1071	2.5	1.6	15	13890	VF 150_15	— P132	— V 10 F	P132	BN132S4	270-271
67	12.7	542	1045	2.0	1.3	15	12140	VF 130_15	— P132	— V 10 F	P132	BN132S4	268-269
95	17.9	388	698	2.4	1.4	7	10680	VF 130_7	— P132	— V 10 F	P132	BN132MB6	268-269
100	19.0	374	731	3.2	2.1	10	12370	VF 150_10	— P132	— V 10 F	P132	BN132S4	270-271
100	19.0	374	722	2.4	1.5	10	10850	VF 130_10	— P132	— V 10 F	P132	BN132S4	268-269
143	27.1	265	518	3.2	1.9	7	9710	VF 130_7	— P132	— V 10 F	P132	BN132S4	268-269

## 7.5 kW

8.3	1.7	4680	8928	1.2	0.6	80	52000	VF 250_80	— P160	— V 15 UF	P160	BN160M6	275
10.0	1.9	3654	6728	1.3	0.7	100	50000	VF 250_100	— P132	— V 10 F	P132	BN132MA4	275
11.1	2.2	3834	7344	1.6	0.9	60	52000	VF 250_60	— P160	— V 15 UF	P160	BN160M6	275
11.1	2.2	3672	7020	1.1	0.6	60	34500	VF 210_60	— P160	— V 15 UF	P160	BN160M6	274
12.5	2.4	3109	5754	1.7	0.9	80	50000	VF 250_80	— P132	— V 10 F	P132	BN132MA4	275
12.5	2.4	3016	5568	1.1	0.7	80	33000	VF 210_80	— P132	— V 10 F	P132	BN132MA4	274
13.3	2.6	3195	6120	1.3	0.7	50	34500	VF 210_50	— P160	— V 15 UF	P160	BN160M6	274
16.7	3.2	2506	4733	2.2	1.3	60	50000	VF 250_60	— P132	— V 10 F	P132	BN132MA4	275
16.7	3.2	2436	4524	1.5	1.0	60	33000	VF 210_60	— P132	— V 10 F	P132	BN132MA4	274
16.7	3.2	2471	4594	1.1	0.7	60	19000	VF 185_60	— P132	— V 10 F	P132	BN132MA4	272-273
20.0	3.8	2088	3944	1.9	1.1	50	33000	VF 210_50	— P132	— V 10 F	P132	BN132MA4	274
20.0	3.8	2117	3944	1.4	0.8	50	19000	VF 185_50	— P132	— V 10 F	P132	BN132MA4	272-273
22.1	4.4	2133	4158	1.7	1.0	30	34500	VF 210_30	— P160	— V 15 UF	P160	BN160M6	274
22.1	4.4	2133	4158	1.2	0.7	30	19500	VF 185_30	— P160	— V 15 UF	P160	BN160M6	272-273
25.0	4.8	1740	3294	2.5	1.5	40	33000	VF 210_40	— P132	— V 10 F	P132	BN132MA4	274

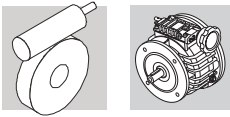

## 7.5 kW





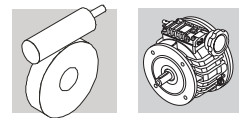

$n_2$ min <sup>-1</sup>	$n_2'$ min <sup>-1</sup>	$M_2$ Nm	$M_2'$ Nm	<b>S</b>	<b>S'</b>	<b>i</b>	$R_{n2}$ N					
25.0	4.8	1763	3294	1.8	1.1	40	19000	VF 185_40	— P132	— V 10 F	P132 BN132MA4	272-273
25.0	4.8	1717	3202	1.0	0.6	40	15500	VF 150_40	— P132	— V 10 F	P132 BN132MA4	270-271
33	6.3	1392	2680	2.4	1.5	30	33000	VF 210_30	— P132	— V 10 F	P132 BN132MA4	274
33	6.3	1409	2680	1.7	1.0	30	19000	VF 185_30	— P132	— V 10 F	P132 BN132MA4	272-273
33	6.3	1340	2540	1.2	0.8	30	15500	VF 150_30	— P132	— V 10 F	P132 BN132MA4	270-271
43	8.3	1094	2081	1.4	0.9	23	14770	VF 150_23	— P132	— V 10 F	P132 BN132MA4	270-271
43	8.3	1081	2054	1.0	0.6	23	12500	VF 130_23	— P132	— V 10 F	P132 BN132MA4	268-269
44	8.8	1134	2241	1.3	0.8	15	13980	VF 150_15	— P160	— V 15 UF	P160 BN160M6	270-271
50	9.5	963	1856	1.6	1.0	20	14270	VF 150_20	— P132	— V 10 F	P132 BN132MA4	270-271
50	9.5	951	1833	1.1	0.7	20	12130	VF 130_20	— P132	— V 10 F	P132 BN132MA4	268-269
67	12.7	740	1444	1.8	1.2	15	13170	VF 150_15	— P132	— V 10 F	P132 BN132MA4	270-271
67	12.7	731	1409	1.5	1.0	15	11370	VF 130_15	— P132	— V 10 F	P132 BN132MA4	268-269
95	18.9	554	1096	2.3	1.3	7	11370	VF 150_7	— P160	— V 15 UF	P160 BN160M6	270-271
100	19.0	505	986	2.4	1.5	10	11820	VF 150_10	— P132	— V 10 F	P132 BN132MA4	270-271
100	19.0	505	974	1.8	1.1	10	10260	VF 130_10	— P132	— V 10 F	P132 BN132MA4	268-269
143	27.1	357	698	2.4	1.4	7	9210	VF 130_7	— P132	— V 10 F	P132 BN132MA4	268-269

## 9.2 kW

10.0	1.9	4536	8352	1.1	0.6	100	50000	VF 250_100	— P132	— V 10 F	P132 BN132MB4	275
12.5	2.4	3859	7142	1.3	0.8	80	50000	VF 250_80	— P132	— V 10 F	P132 BN132MB4	275
16.7	3.2	3110	5875	1.8	1.1	60	50000	VF 250_60	— P132	— V 10 F	P132 BN132MB4	275
16.7	3.2	3024	5616	1.2	0.8	60	33000	VF 210_60	— P132	— V 10 F	P132 BN132MB4	274
20.0	3.8	2628	4896	2.4	1.3	50	50000	VF 250_50	— P132	— V 10 F	P132 BN132MB4	275
20.0	3.8	2592	4896	1.5	0.9	50	33000	VF 210_50	— P132	— V 10 F	P132 BN132MB4	274
20.0	3.8	2628	4896	1.1	0.7	50	19000	VF 185_50	— P132	— V 10 F	P132 BN132MB4	272-273
25.0	4.8	2189	4147	3.0	1.7	40	50000	VF 250_40	— P132	— V 10 F	P132 BN132MB4	275
25.0	4.8	2160	4090	2.0	1.2	40	33000	VF 210_40	— P132	— V 10 F	P132 BN132MB4	274
25.0	4.8	2189	4090	1.4	0.9	40	19000	VF 185_40	— P132	— V 10 F	P132 BN132MB4	272-273
33	6.3	1750	3413	3.1	1.8	30	48950	VF 250_30	— P132	— V 10 F	P132 BN132MB4	275
33	6.3	1728	3326	2.0	1.2	30	33000	VF 210_30	— P132	— V 10 F	P132 BN132MB4	274
33	6.3	1750	3326	1.4	0.8	30	19000	VF 185_30	— P132	— V 10 F	P132 BN132MB4	272-273
33	6.3	1663	3154	1.0	0.6	30	14820	VF 150_30	— P132	— V 10 F	P132 BN132MB4	270-271
43	8.3	1358	2583	1.1	0.7	23	13900	VF 150_23	— P132	— V 10 F	P132 BN132MB4	270-271



## 9.2 kW

$n_2$ min <sup>-1</sup>	$n_2'$ min <sup>-1</sup>	$M_2$ Nm	$M_2'$ Nm	<b>S</b>	<b>S'</b>	<b>i</b>	$R_{n2}$ N	 V_	 P(IEC)	 C	 F	 IEC	
<b>50</b>	<b>9.5</b>	1195	2333	3.2	2.0	20	33000	<b>VF 210_20</b>	— P132	— V 10 F	<b>P132</b>	<b>BN132MB4</b>	274
<b>50</b>	<b>9.5</b>	1195	2304	1.3	0.8	20	13480	<b>VF 150_20</b>	— P132	— V 10 F	<b>P132</b>	<b>BN132MB4</b>	270-271
<b>67</b>	<b>12.7</b>	918	1793	1.5	0.9	15	12500	<b>VF 150_15</b>	— P132	— V 10 F	<b>P132</b>	<b>BN132MB4</b>	270-271
<b>67</b>	<b>12.7</b>	907	1750	1.2	0.8	15	10640	<b>VF 130_15</b>	— P132	— V 10 F	<b>P132</b>	<b>BN132MB4</b>	268-269
<b>100</b>	<b>19.0</b>	626	1224	1.9	1.2	10	11320	<b>VF 150_10</b>	— P132	— V 10 F	<b>P132</b>	<b>BN132MB4</b>	270-271
<b>100</b>	<b>19.0</b>	626	1210	1.4	0.9	10	9700	<b>VF 130_10</b>	— P132	— V 10 F	<b>P132</b>	<b>BN132MB4</b>	268-269
<b>143</b>	<b>27.1</b>	449	877	2.6	1.6	7	10120	<b>VF 150_7</b>	— P132	— V 10 F	<b>P132</b>	<b>BN132MB4</b>	270-271
<b>143</b>	<b>27.1</b>	444	867	1.9	1.2	7	8740	<b>VF 130_7</b>	— P132	— V 10 F	<b>P132</b>	<b>BN132MB4</b>	268-269

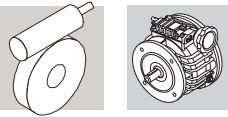

# VF 44

## 23.9 - Dimensioni

## 23.9 - Dimensions

## 23.9 - Abmessungen

## 23.9 - Dimensions

**VF 44 N  
+  
V\_P(IEC)**

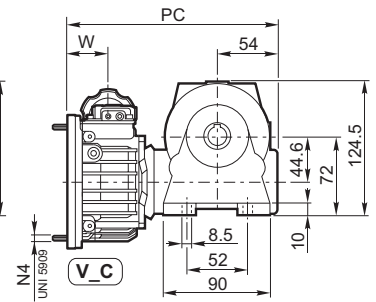
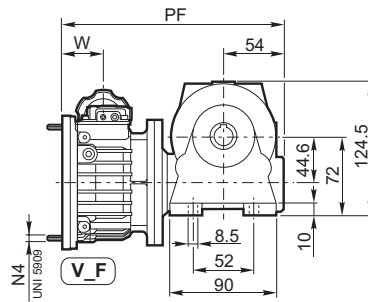
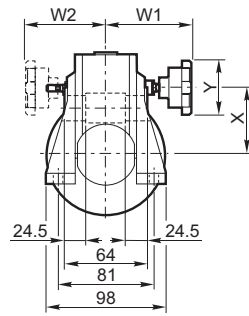

**VF 44 A  
+  
V\_P(IEC)**

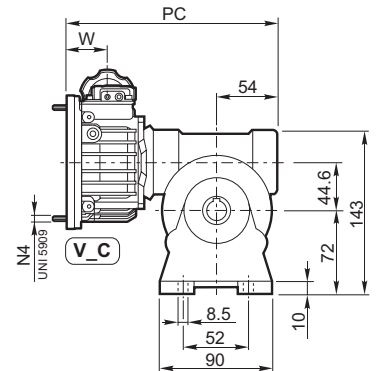
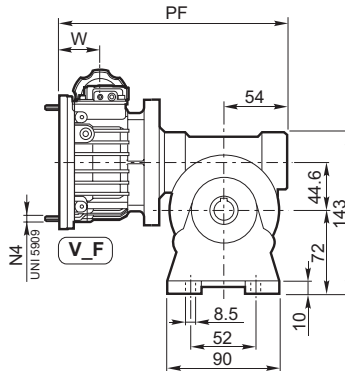
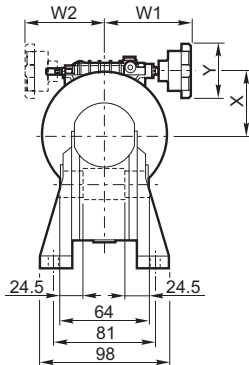

**VF 44 V  
+  
V\_P(IEC)**

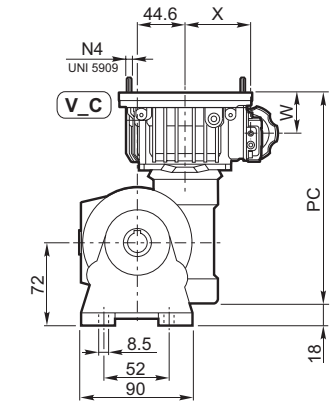
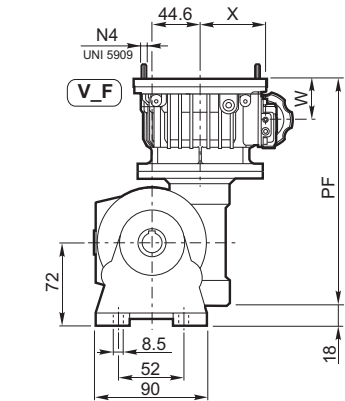
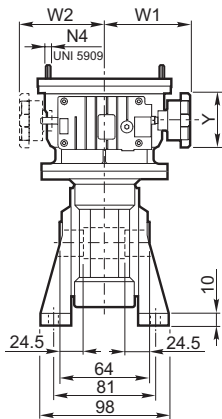

**VF 44 F  
+  
V\_P(IEC)**

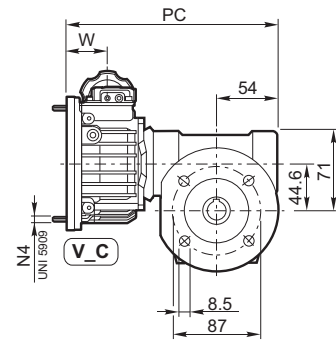
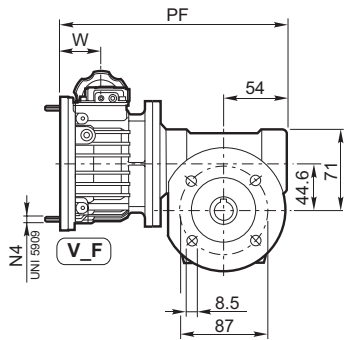
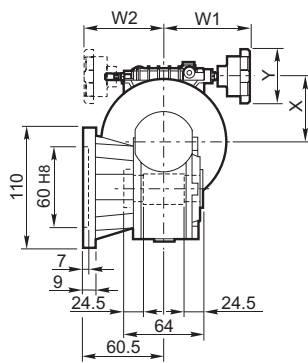

**VF 44 FA  
+  
V\_P(IEC)**

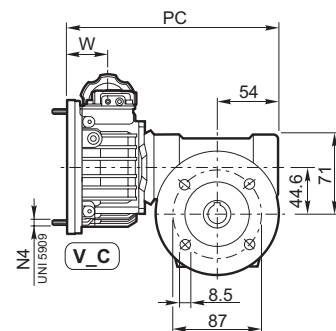
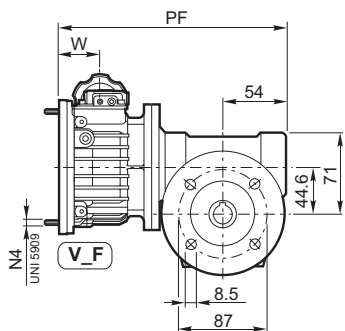
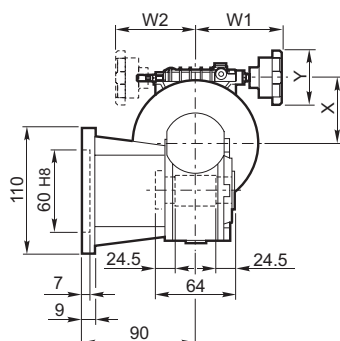

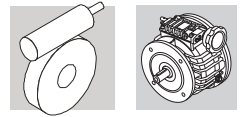

## VF 44 P + V\_P(IEC)

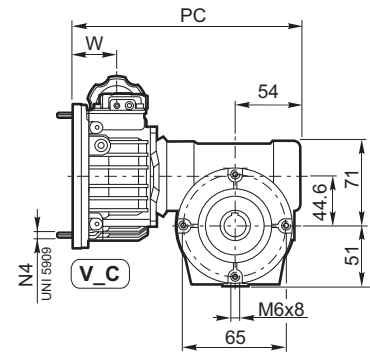
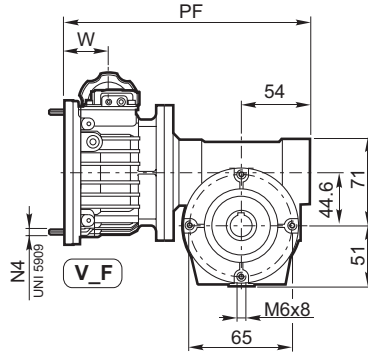
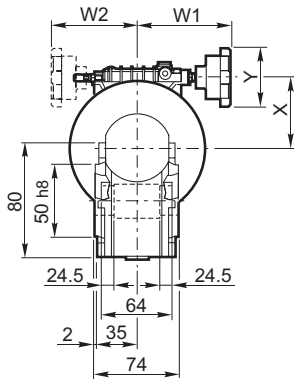

## VF 44 U + V\_P(IEC)

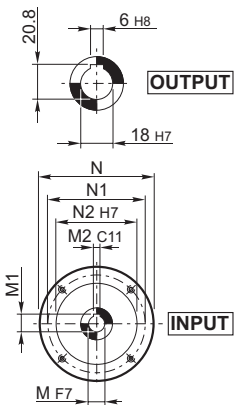
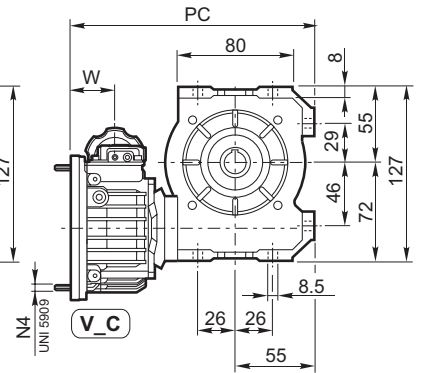
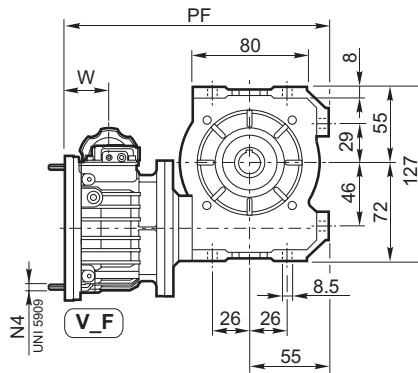
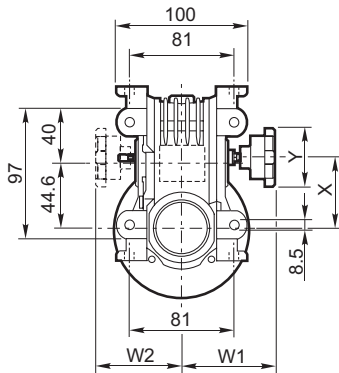
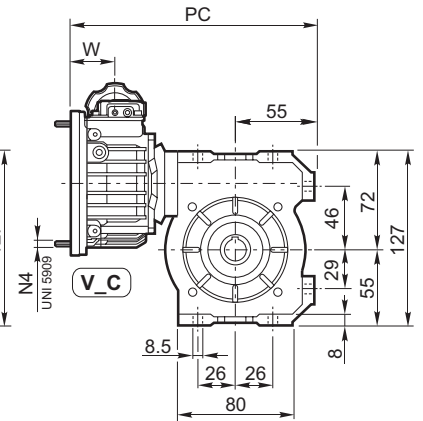
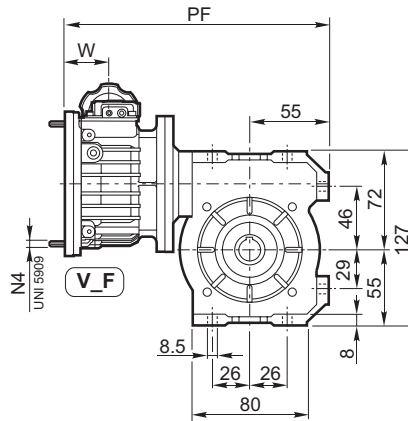
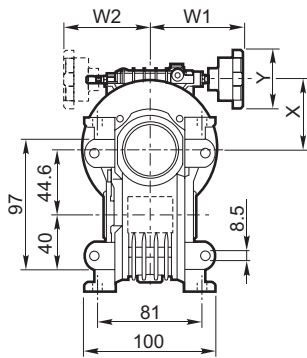

	IEC	V_C - V_F											VF44 + V_C		VF44 + V_F		
		N	N1	N2	N4	M	M1	M2	W	W1	W2	X	Y	PC	kg	PF	kg
VF 44_ V 0.25	P63	140	115	95	M8x20	11	12.8	4	45.0	115	110	70	83	203 <sup>1)</sup> 204 <sup>2)</sup>	6.3	228 <sup>1)</sup> 229 <sup>2)</sup>	6.5

<sup>1)</sup> N - A - V - F - FA - P    <sup>2)</sup> U

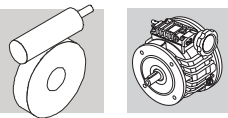

# VF 49

## VF 49 N + V\_P(IEC)

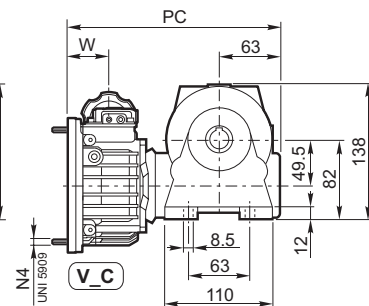
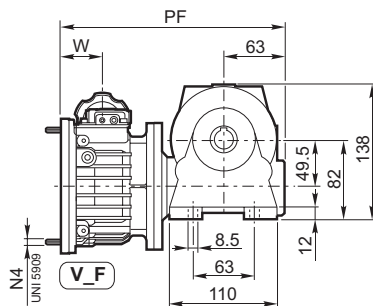
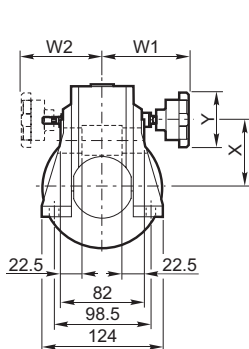

## VF 49 A + V\_P(IEC)

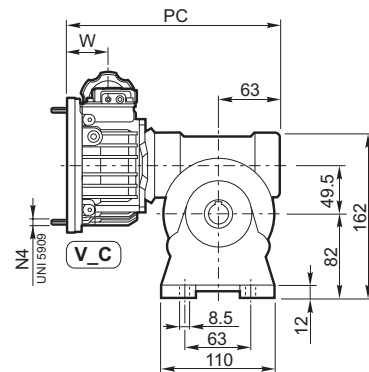
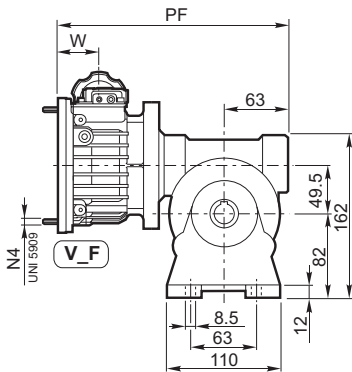
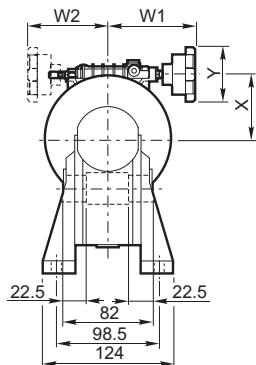

## VF 49 V + V\_P(IEC)

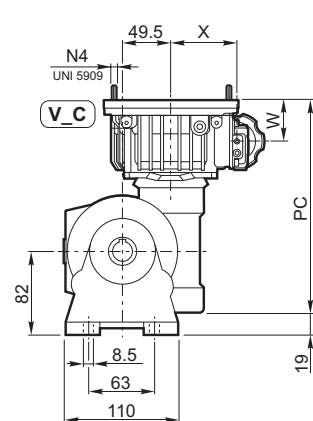
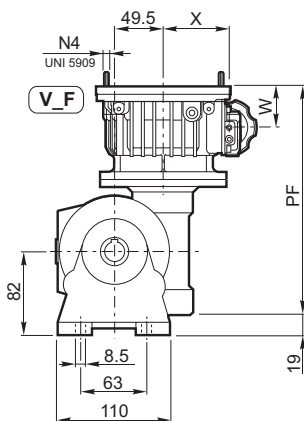
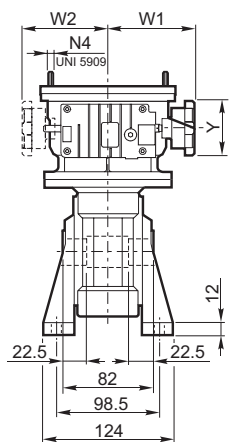

## VF 49 F + V\_P(IEC)

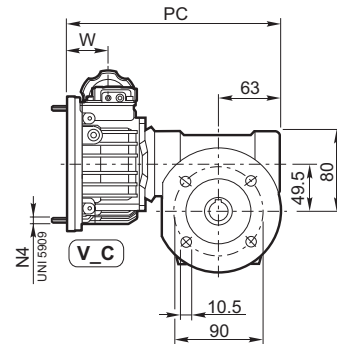
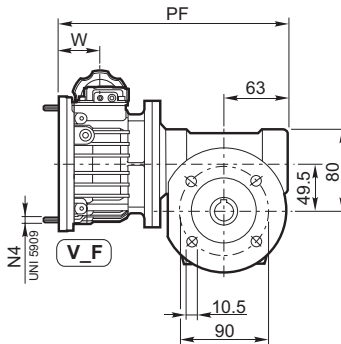
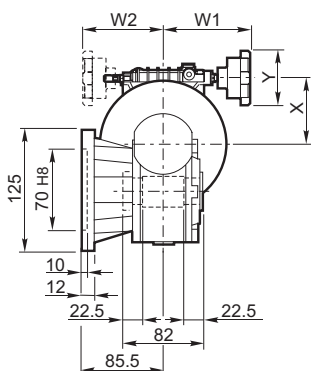

## VF 49 FA + V\_P(IEC)

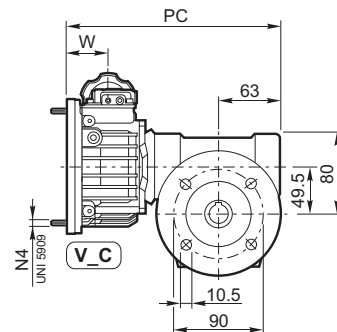
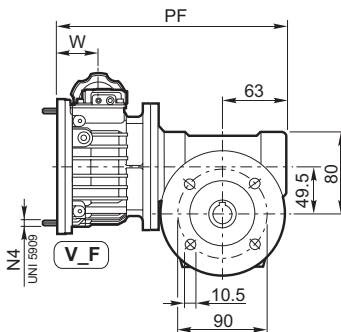
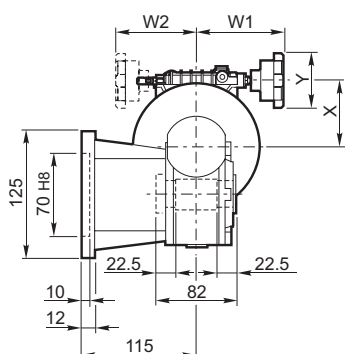



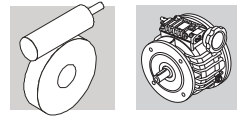

## VF 49 P + V\_P(IEC)

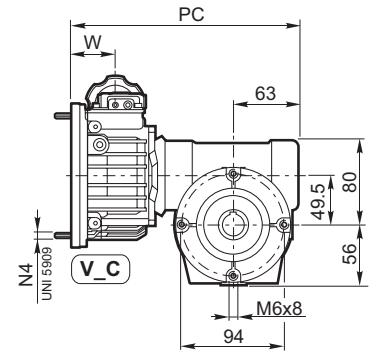
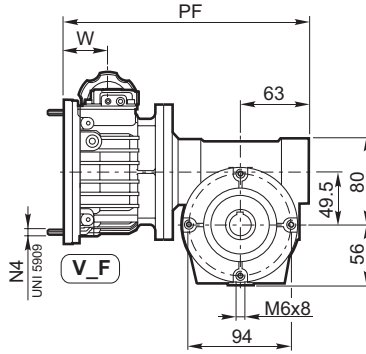
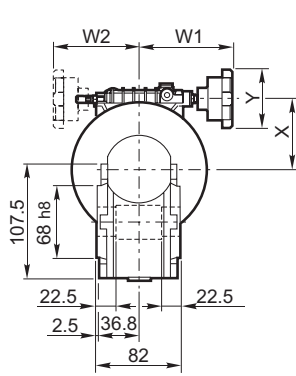

## VF 49 U + V\_P(IEC)

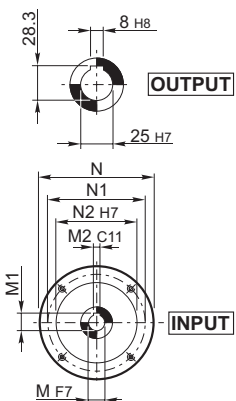
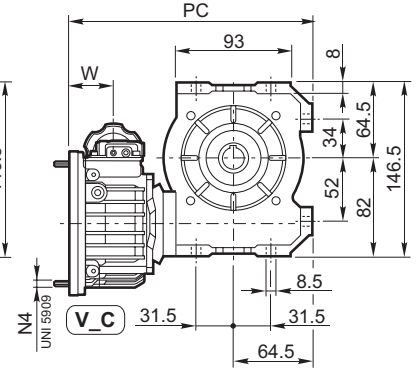
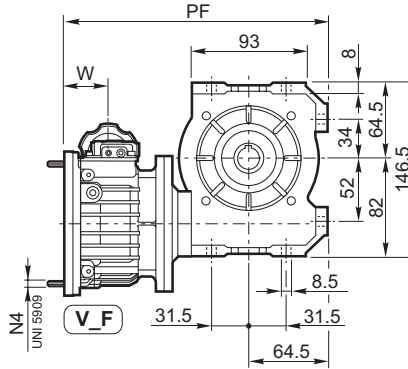
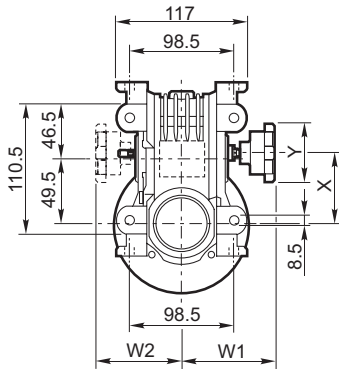
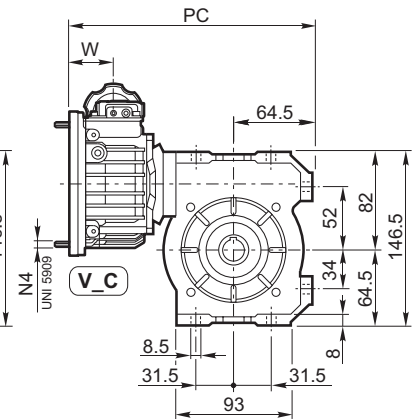
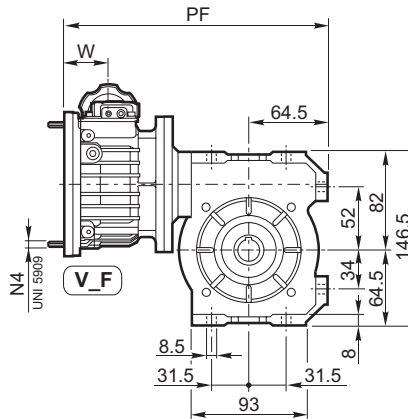
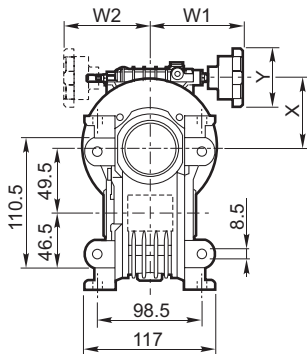

VF 49	V	IEC	V_C - V_F											VF49 + V_C		VF49 + V_F		
			N	N1	N2	N4	M	M1	M2	W	W1	W2	X	Y	PC	Kg	PF	Kg
	<b>V 0.25</b>	<b>P63</b>	140	115	95	M8x20	11	12.8	4	45.0	115	110	70	83	222 <sup>1)</sup> /223 <sup>2)</sup>	7.2	242 <sup>1)</sup> /243 <sup>2)</sup>	7.5
	<b>V 0.5</b>	<b>P71</b>	160	130	110	M8x20	14	16.3	5	47.5	115	110	78	83	224 <sup>1)</sup> /225 <sup>2)</sup>	9.9	244 <sup>1)</sup> /245 <sup>2)</sup>	10.5
	<b>V 0.5</b>	<b>P80</b>	200	165	130	M10x20	19	20.8*	6	51.5	115	110	78	83	228 <sup>1)</sup> /229 <sup>2)</sup>	9.9	248 <sup>1)</sup> /248 <sup>2)</sup>	10.5
	<b>V 1</b>	<b>P80</b>	200	165	130	M10x20	19	21.8	6	59.0	133	124	97	83	—	—	270 <sup>1)</sup> /271 <sup>2)</sup>	17.1
	<b>V 1</b>	<b>P90</b>	200	165	130	M10x20	24	26.3**	8	59.0	133	124	97	83	—	—	270 <sup>1)</sup> /271 <sup>2)</sup>	17.1

\* Utilizzare linguetta ribassata di ns. fornitura 6x5x30 "A"

\* Use thin parallel key 6x5x30 "A" supplied by Bonfiglioli

\* Den bei uns verfügbaren flachen Federkeil "A" 6x5x30 verwenden

\* Utiliser une languette abaissée de notre fabrication 6x5x30 "A"

\*\* Utilizzare linguetta ribassata di ns. fornitura 8x6x35 "A"

\*\* Use thin parallel key 8x6x35 "A" supplied by Bonfiglioli

\*\* Den bei uns verfügbaren flachen Federkeil "A" 8x6x35 verwenden

\*\* Utiliser une languette abaissée de notre fabrication 8x6x35 "A"

1) N - A - V - F - FA - P 2) U

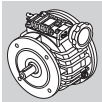
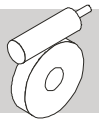

# W 63

## W 63 U + V\_P(IEC)

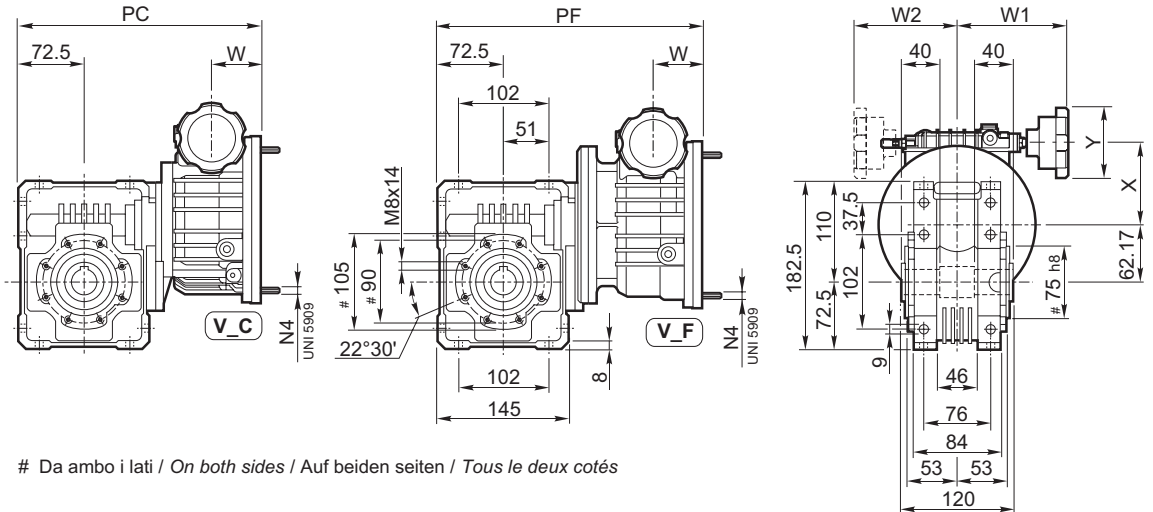

# Da ambo i lati / On both sides / Auf beiden Seiten / Tous le deux cotés

## W 63 UFC + V\_P(IEC)

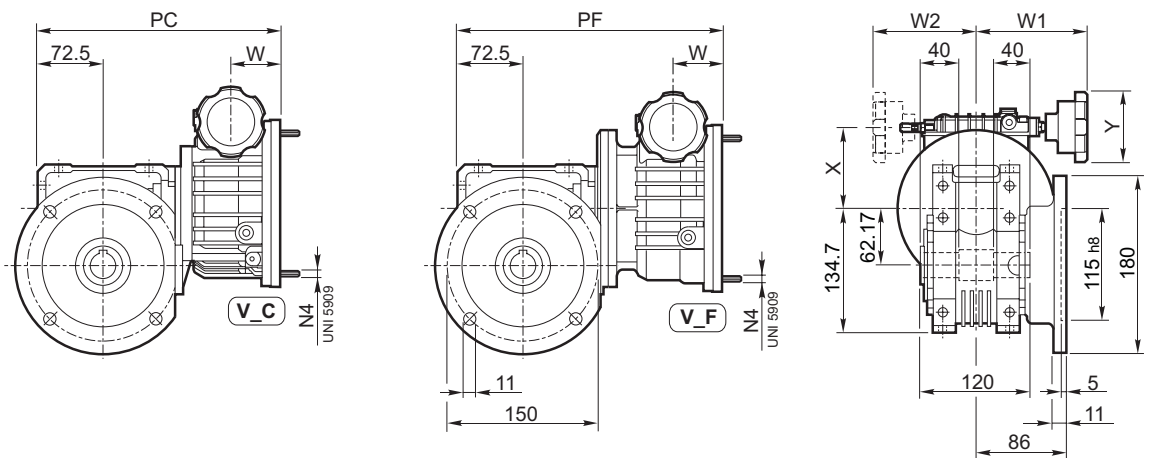

## W 63 UF + V\_P(IEC)

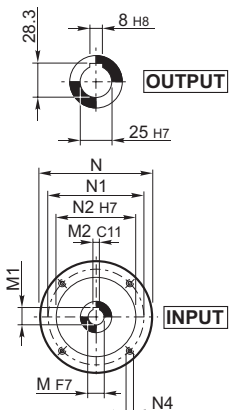
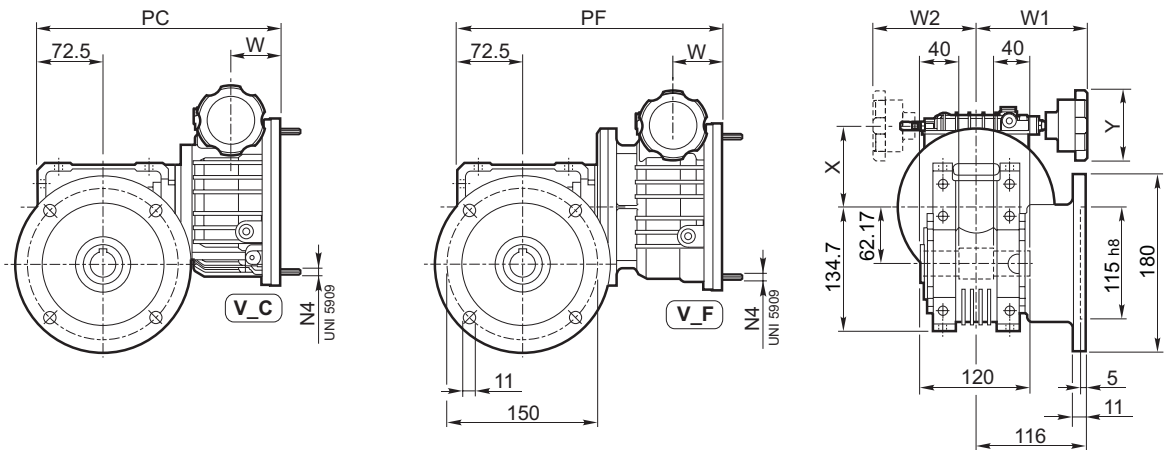

	IEC	V_C - V_F											W63_ + V_C		W63_ + V_F			
		N	N1	N2	N4	M	M1	M2	W	W1	W2	X	Y	PC	Kg	PF	Kg	
W 63_	V 0.5	P71	160	130	110	M8x20	14	16.3	5	47.5	115	110	78	83	255	13.2	279	13.8
	V 0.5	P80	200	165	130	M10x20	19	20.8*	6	51.5	115	110	78	83	259	13.2	283	13.8
	V 1	P80	200	165	130	M10x20	19	21.8	6	59	133	124	97	83	274	19.6	312	21
	V 1	P90	200	165	130	M10x20	24	26.3**	8	59	133	124	97	83	274	19.6	312	21

\* Utilizzare linguetta ribassata di ns. forniture 6x5x30 "A"

\*\* Use thin parallel key 6x5x30 "A" supplied by Bonfiglioli

\* Den bei uns verfügbaren flachen Federkeil "A" 6x5x30 verwenden

\*\* Utiliser une languette abaissée de notre fabrication 6x5x30 "A"

\*\* Utilizzare linguetta ribassata di ns. forniture 8x6x35 "A"

\*\* Use thin parallel key 8x6x35 "A" supplied by Bonfiglioli

\* Den bei uns verfügbaren flachen Federkeil "A" 8x6x35 verwenden

\*\* Utiliser une languette abaissée de notre fabrication 8x6x35 "A"

# W 75

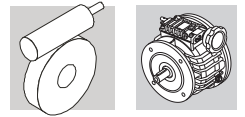

## W 75 U + V\_P(IEC)

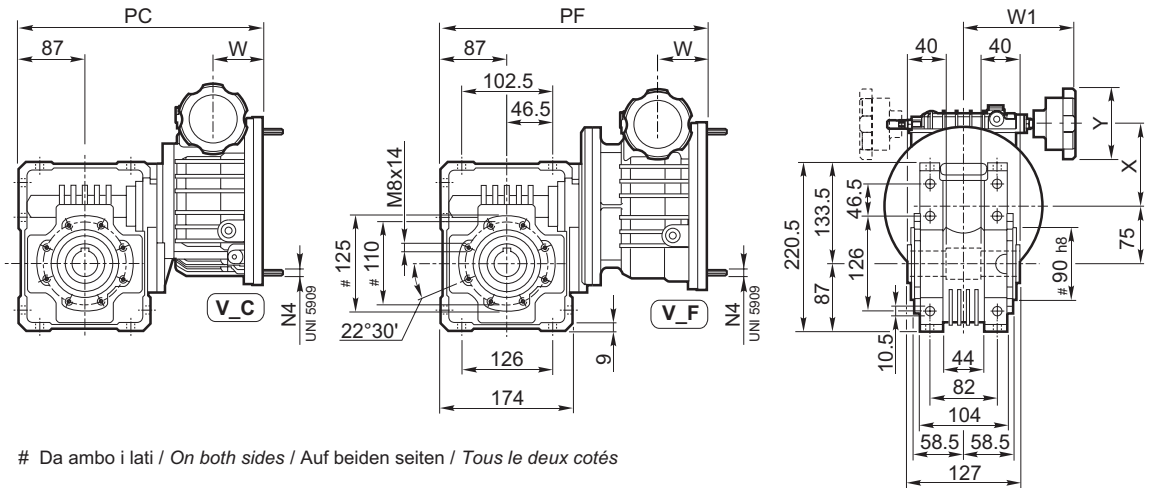

# Da ambo i lati / On both sides / Auf beiden seiten / Tous le deux cotés

## W 75 UFC + V\_P(IEC)

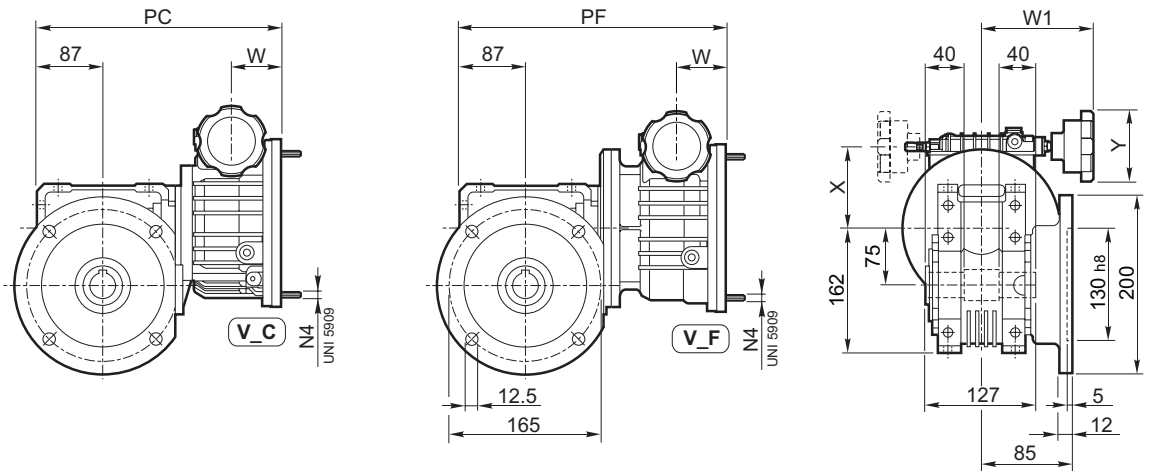

## W 75 UF + V\_P(IEC)

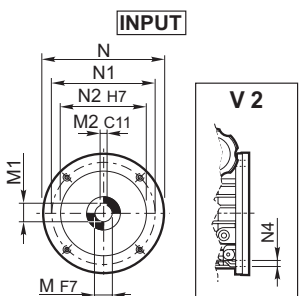
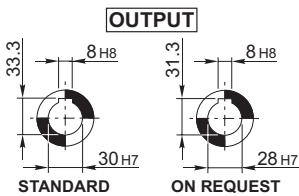
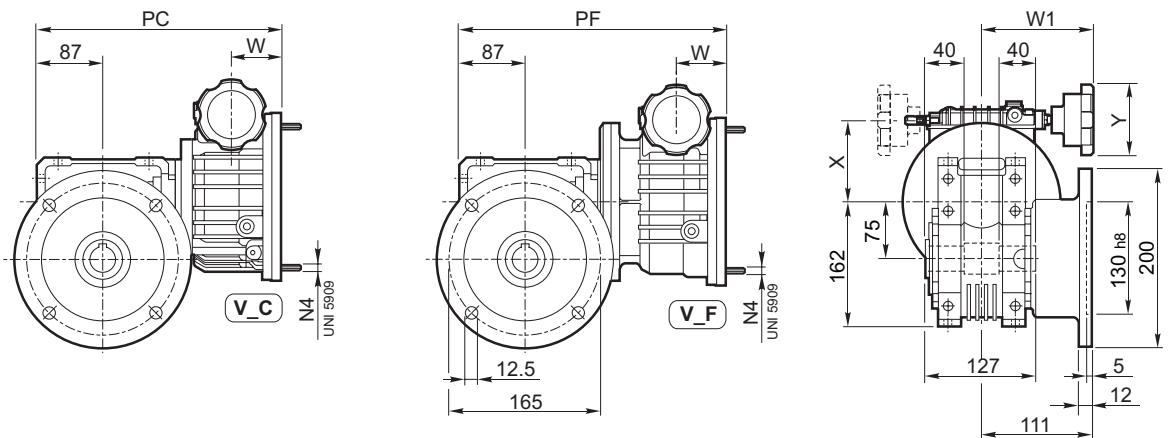

	IEC	V_C - V_F											W75_+ V_C		W75_+ V_F			
		N	N1	N2	N4	M	M1	M2	W	W1	W2	X	Y	PC	Kg	PF	Kg	
W 75_	V 0.5	P71	160	130	110	M8x20	14	16.3	5	47.5	115	110	78	83	—	—	310	17.1
	V 0.5	P80	200	165	130	M10x20	19	20.8*	6	51.5	115	110	78	83	—	—	314	17.0
	V 1	P80	200	165	130	M10x20	19	21.8	6	59	133	124	97	83	307	23	336	24
	V 1	P90	200	165	130	M10x20	24	26.3**	8	59	133	124	97	83	307	23	336	24
	V 2	P90	200	165	130	M10x15	24	27.3	8	74.1	137	120	113	83	333	27	360	28

\* Utilizzare linguetta ribassata di ns. fornitura 6x5x30 "A"

\*\* Use thin parallel key 6x5x30 "A" supplied by Bonfiglioli

\* Den bei uns verfügbaren flachen Federkeil "A" 6x5x30 verwenden

\*\* Utiliser une languette abaissée de notre fabrication 6x5x30 "A"

\*\* Utilizzare linguetta ribassata di ns. fornitura 8x6x35 "A"

\*\* Use thin parallel key 8x6x35 "A" supplied by Bonfiglioli

\*\* Den bei uns verfügbaren flachen Federkeil "A" 8x6x35 verwenden

\*\* Utiliser une languette abaissée de notre fabrication 8x6x35 "A"

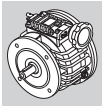
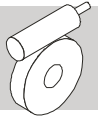

# W 86

## W 86 U + V\_P(IEC)

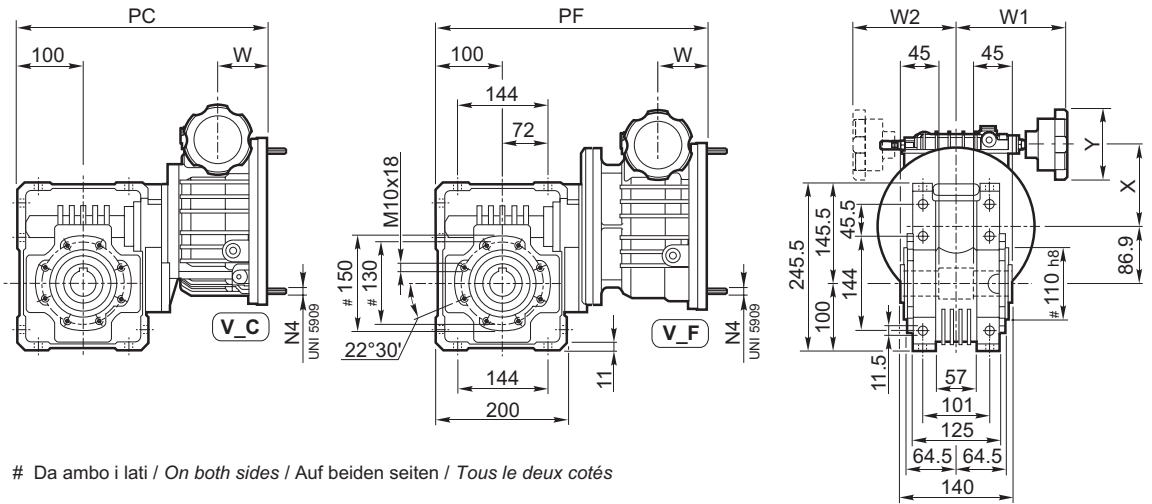

# Da ambo i lati / On both sides / Auf beiden Seiten / Tous le deux cotés

## W 86 UFC + V\_P(IEC)

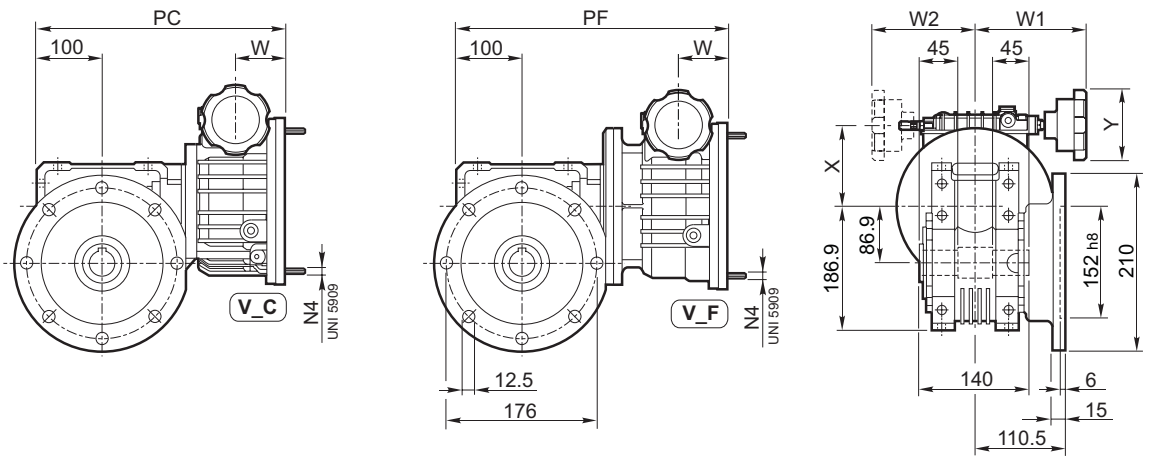

## W 86 UF + V\_P(IEC)

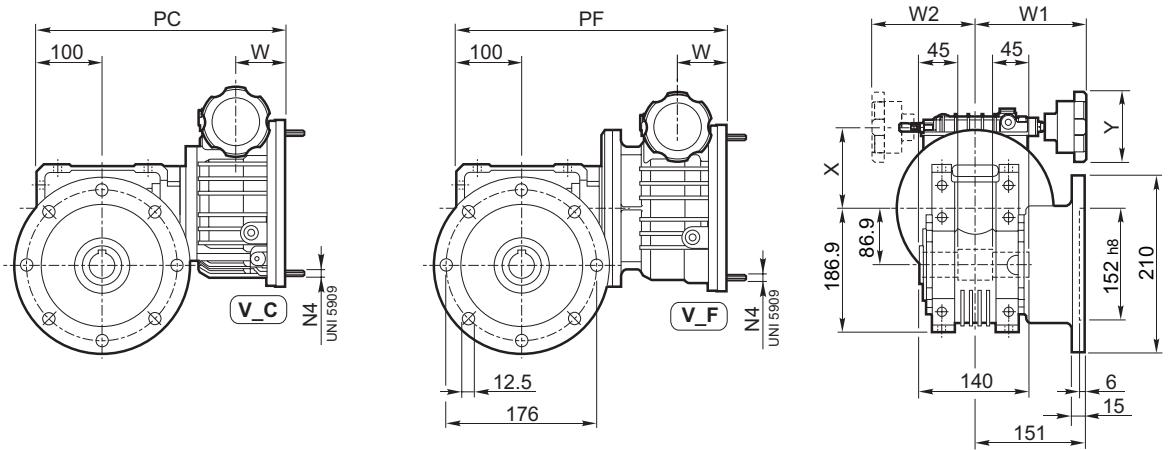

### OUTPUT

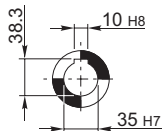

### INPUT

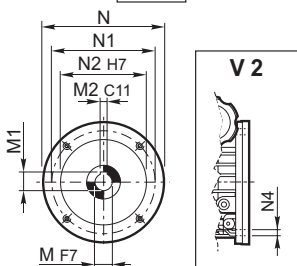

	IEC	V_C - V_F											W86_ + V_C		W86_ + V_F			
		N	N1	N2	N4	M	M1	M2	W	W1	W2	X	Y	PC	Kg	PF	Kg	
W 86_	V 0.5	P71	160	130	110	M8x20	14	16.3	5	47.5	115	110	78	83	—	—	339	21
	V 0.5	P80	200	165	130	M10x20	19	20.8*	6	51.5	115	110	78	83	—	—	343	21
	V 1	P80	200	165	130	M10x20	19	21.8	6	59	133	124	97	83	336	32	365	28
	V 1	P90	200	165	130	M10x20	24	26.3**	8	59	133	124	97	83	336	—	365	28
	V 2	P90	200	165	130	M10x15	24	27.3	8	74.1	137	120	113	83	362	37	389	33

\* Utilizzare linguetta ribassata di ns. fornitura 6x5x30 "A"

\* Use thin parallel key 6x5x30 "A" supplied by Bonfiglioli

\* Den bei uns verfügbaren flachen Federkeil "A" 6x5x30 verwenden

\* Utiliser une languette abaissée de notre fabrication 6x5x30 "A"

\*\* Utilizzare linguetta ribassata di ns. fornitura 8x6x35 "A"

\*\* Use thin parallel key 8x6x35 "A" supplied by Bonfiglioli

\*\* Den bei uns verfügbaren flachen Federkeil "A" 8x6x35 verwenden

\*\* Utiliser une languette abaissée de notre fabrication 8x6x35 "A"

# W 110

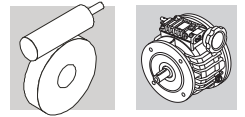

## W 110 U + V\_P(IEC)

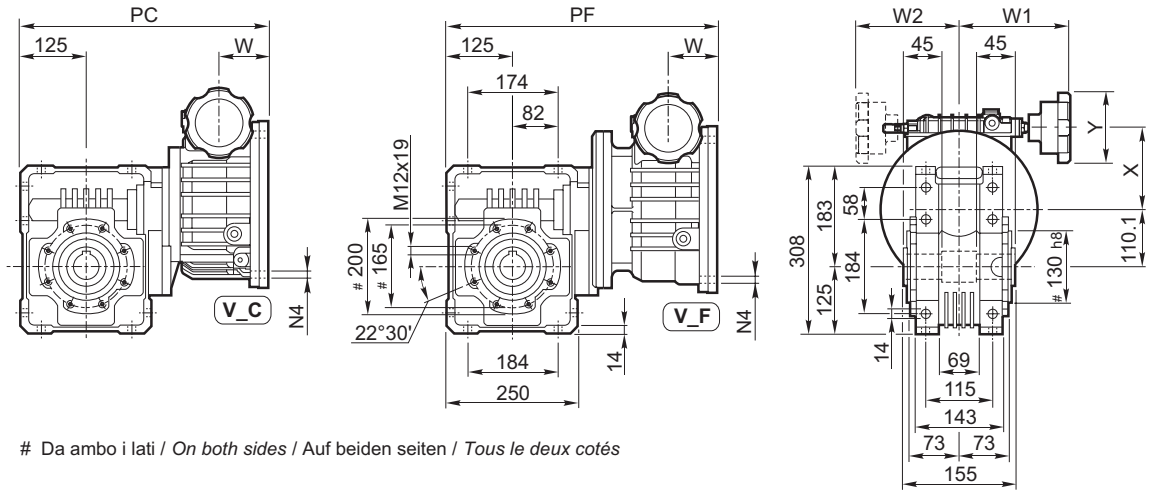

# Da ambo i lati / On both sides / Auf beiden seiten / Tous le deux cotés

## W 110 UFC + V\_P(IEC)

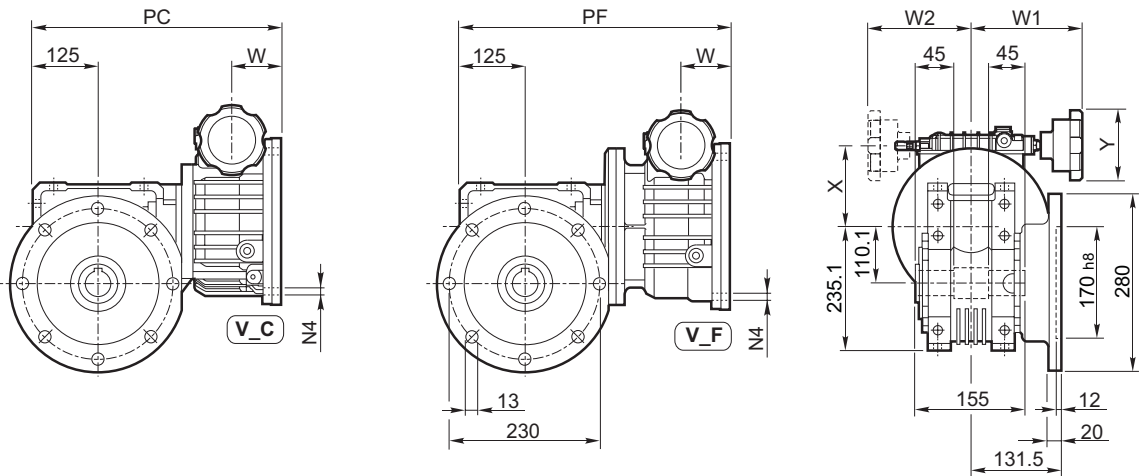

## W 110 UF + V\_P(IEC)

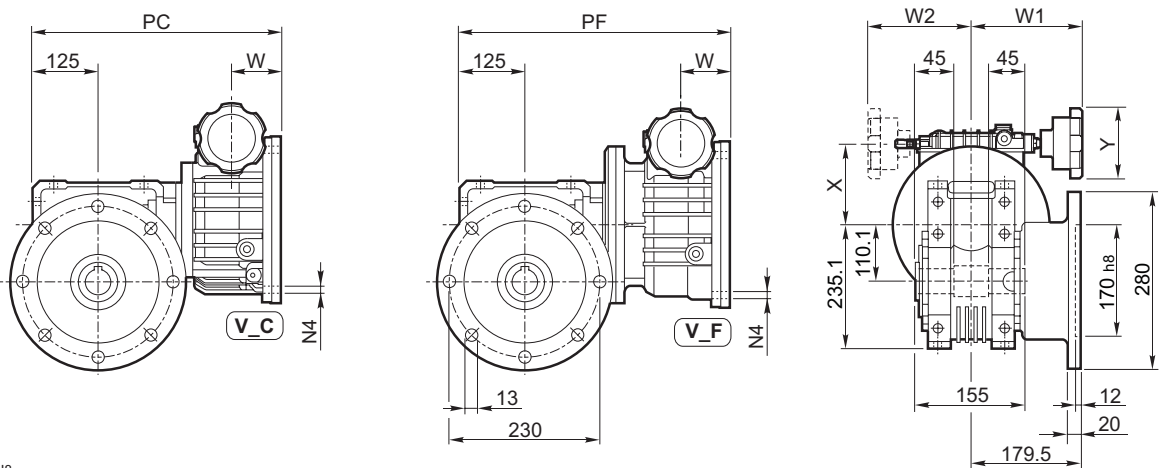

### OUTPUT

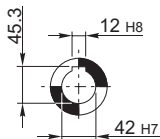

### INPUT

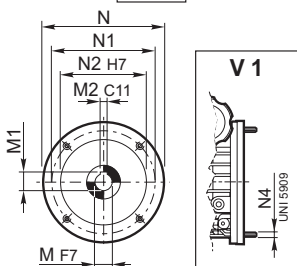

W 110_	V	IEC	V_C - V_F										W110_ + V_C		W110_ + V_F			
			N	N1	N2	N4	M	M1	M2	W	W1	W2	X	Y	PC	KG	PF	KG
W 110_	V 1	P80	200	165	130	M10x20	19	21.8	6	59	133	124	97	83	—	—	280	52
	V 1	P90	200	165	130	M10x20	24	26.3*	8	59	133	124	97	83	—	—	280	52
	V 2	P90	200	165	130	M10x15	24	27.3	8	70	137	120	113	83	277	54	304	57
	V 3	P100	250	215	180	M12	28	31.3	8	91	172.5	—	150.5	109	—	—	506	72
	V 5.5	P112	250	215	180	M12	28	31.3	8	91	172.5	—	150.5	109	—	—	506	73

\* Utilizzare linguetta ribassata di ns. fornitura 8x6x35 "A"

\* Use thin parallel key 8x6x35 "A" supplied by Bonfiglioli

\* Den bei uns verfügbaren flachen Federkeil "A" 8x6x35 verwenden

\* Utiliser une languette abaissée de notre fabrication 8x6x35 "A"

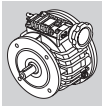
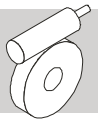

# VF 130

## VF 130 N + V\_P(IEC)

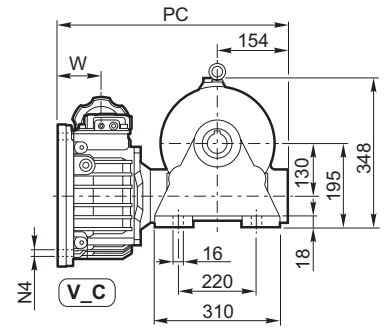
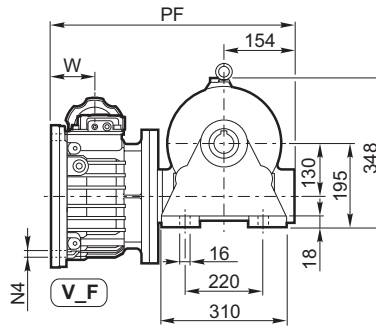
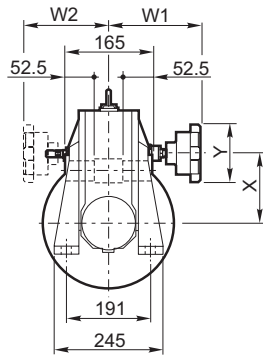

## VF 130 A + V\_P(IEC)

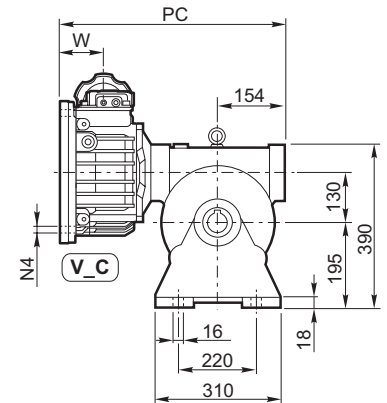
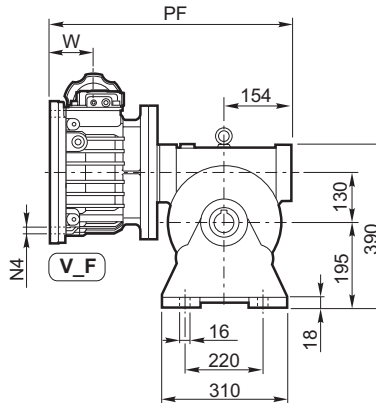
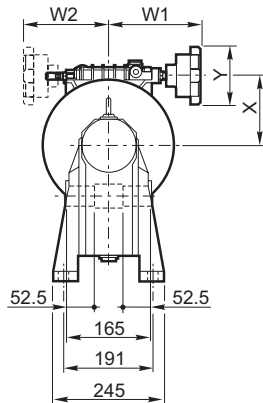

## VF 130 V + V\_P(IEC)

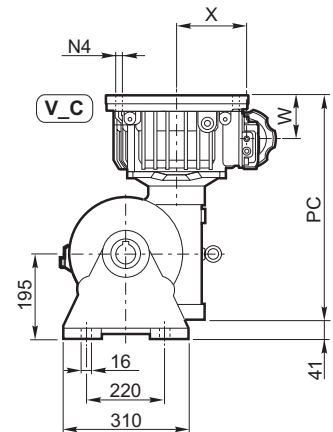
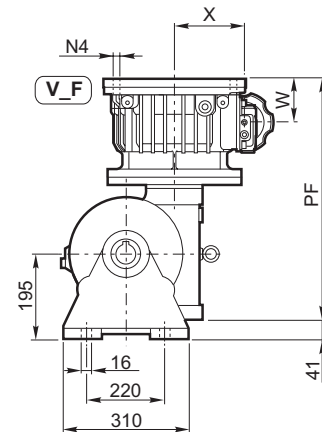
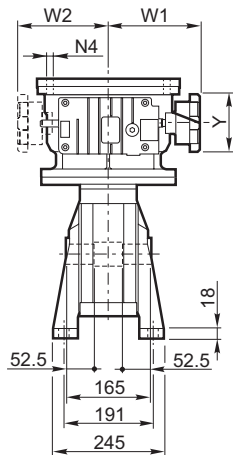

## VF 130 F + V\_P(IEC)

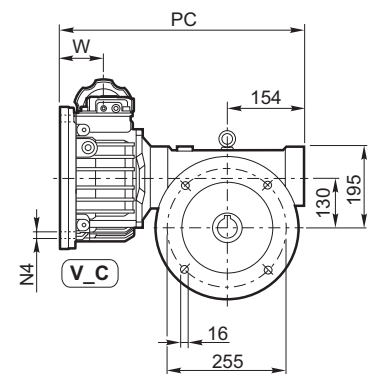
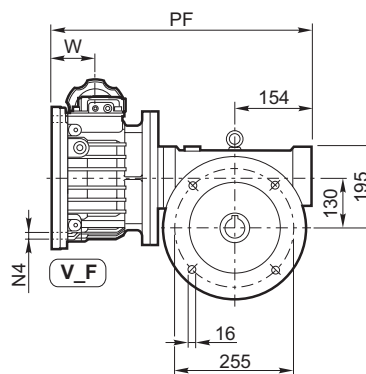
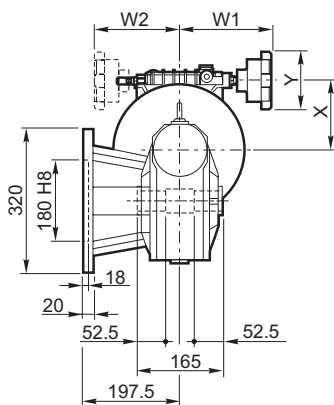

# VF 130

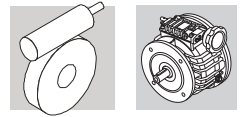

## VF 130 FC/FR + V\_P(IEC)

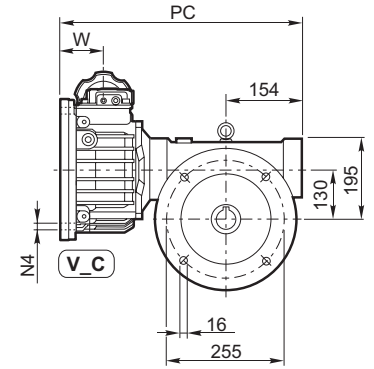
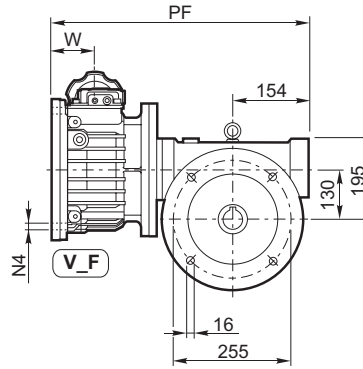
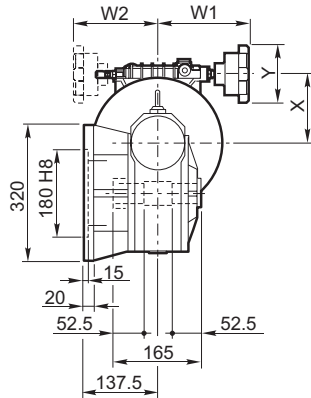

## VF 130 P + V\_P(IEC)

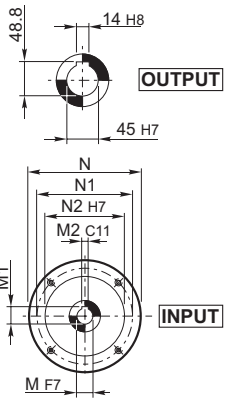
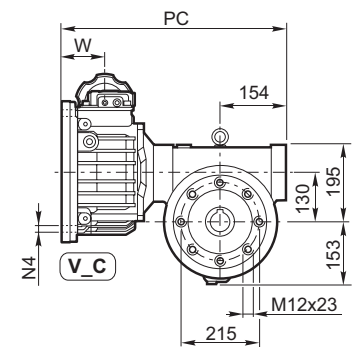
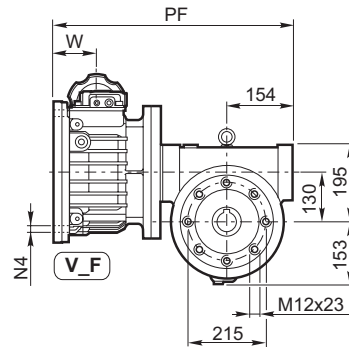
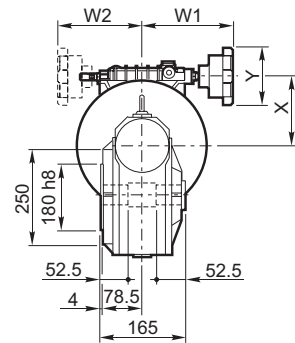

	IEC	V_C - V_F												VF130_+ V_C		VF130_+ V_F		
		N	N1	N2	N4	M	M1	M2	W	W1	W2	X	Y	PC	kg	PF	kg	
VF 130_	V 2	P90	200	165	130	M10x15	24	27.3	8	74.1	137	120	113	83	453	66	500	68
	V 3	P100	250	215	180	M12x23	28	31.3	8	91	172.5	—	150.5	109	479	86	554	88
	V 5.5	P112	250	215	180	M12x23	28	31.3	8	91	172.5	—	150.5	109	479	87	554	89
	V 10	P132	300	265	230	M12x25	38	41.3	10	108	193.5	—	206.5	109	—	—	594.5	146

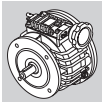
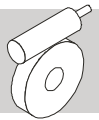

# VF 150

## VF 150 N + V\_P(IEC)

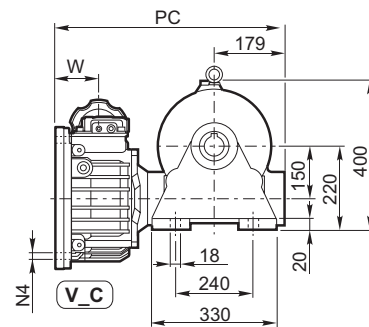
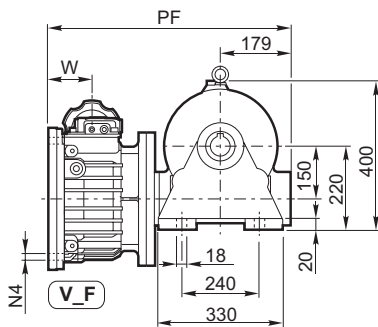
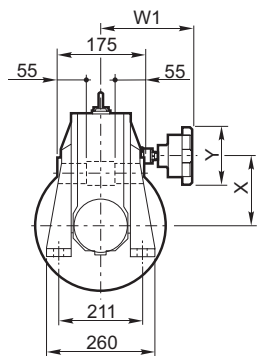

## VF 150 A + V\_P(IEC)

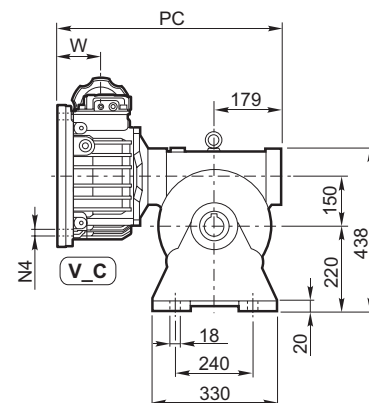
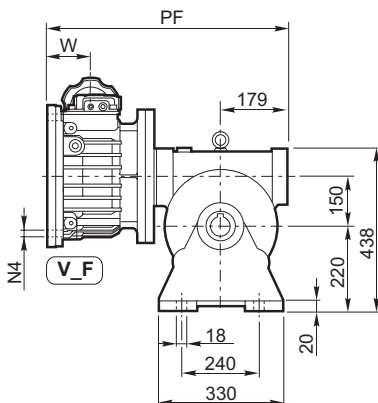
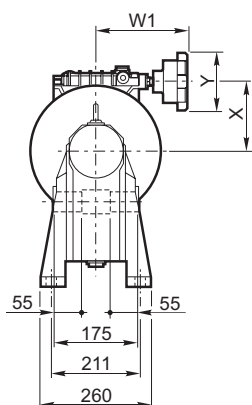

## VF 150 V + V\_P(IEC)

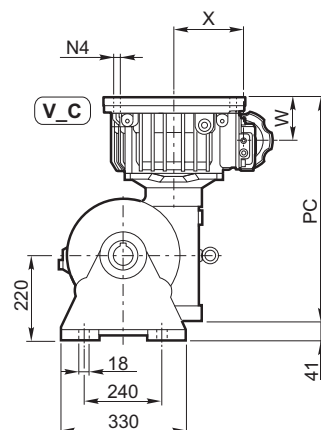
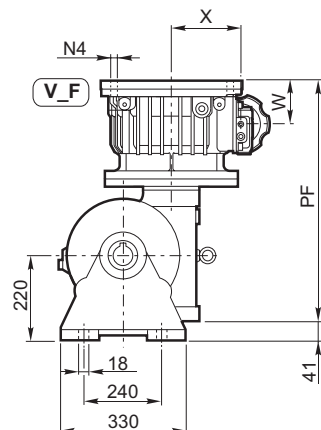
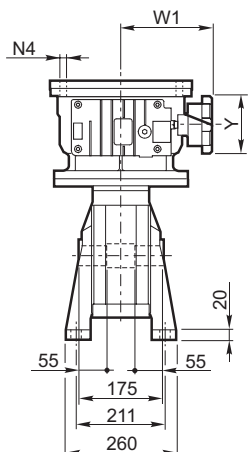

## VF 150 F + V\_P(IEC)

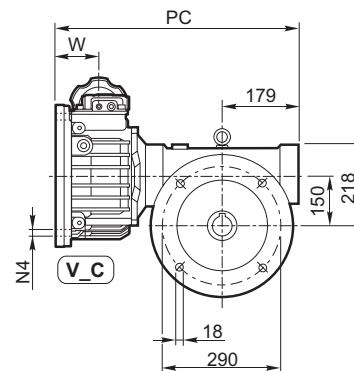
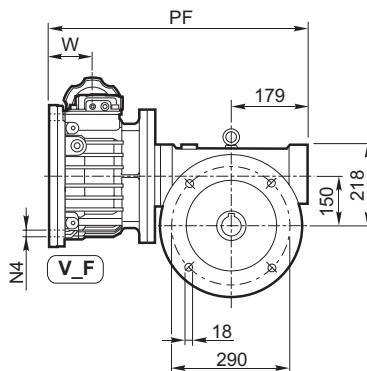
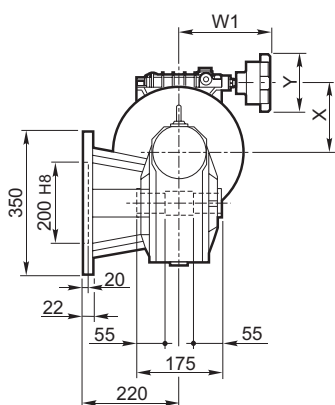



# VF 150

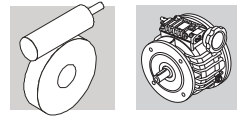

## VF 150 FC/FR + V\_P(IEC)

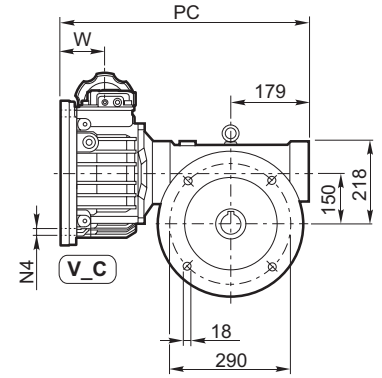
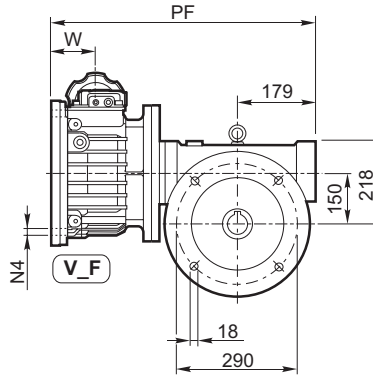
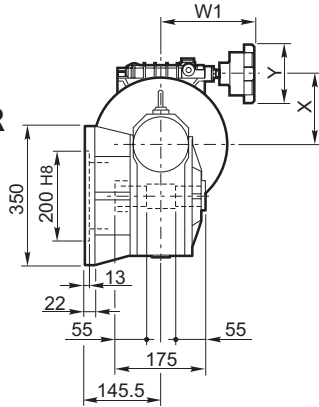

## VF 150 P + V\_P(IEC)

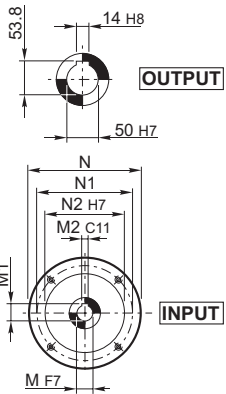
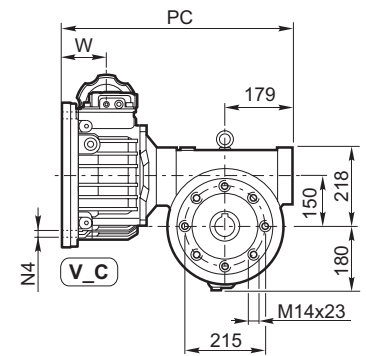
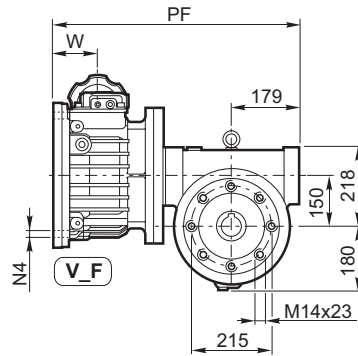
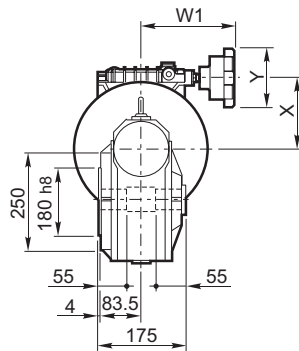

	IEC	V_C - V_F										VF150_ + V_C		VF150_ + V_F			
		N	N1	N2	N4	M	M1	M2	W	W1	X	Y	PC	kg	PF	kg	
VF 150_	V 3	P100	250	215	180	M12x23	28	31.3	8	91	172.5	150.5	109	534	97	584	99
	V 5.5	P112	250	215	180	M12x23	28	31.3	8	91	172.5	150.5	109	534	98	584	100
	V 10	P132	300	265	230	M12x25	38	41.3	10	108	193.5	206.5	109	—	—	624.5	157

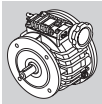
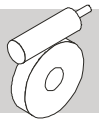

# VF 185

## VF 185 N + V\_P(IEC)

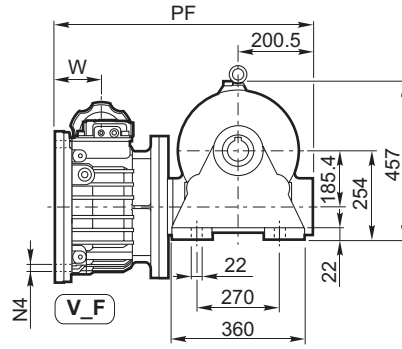
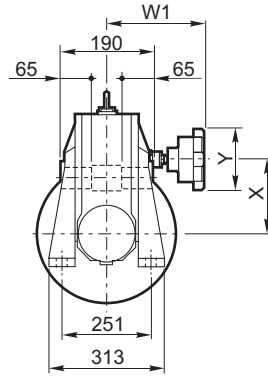

## VF 185 A + V\_P(IEC)

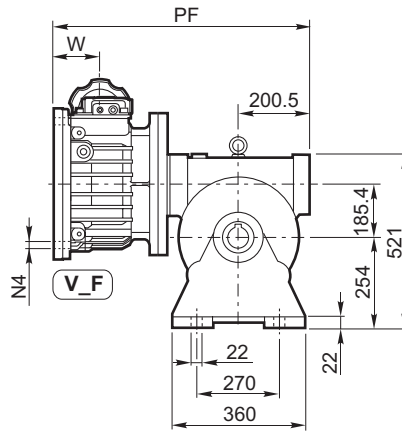
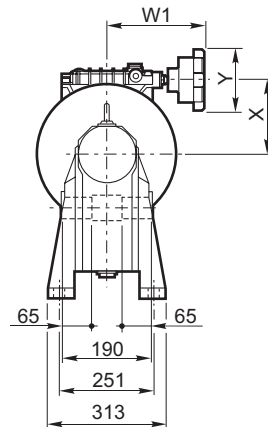

## VF 185 V + V\_P(IEC)

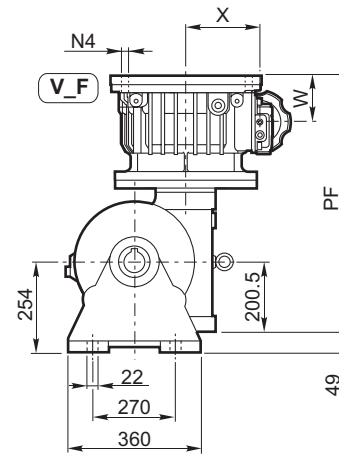
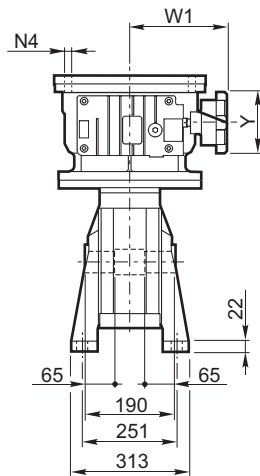

## VF 185 F + V\_P(IEC)

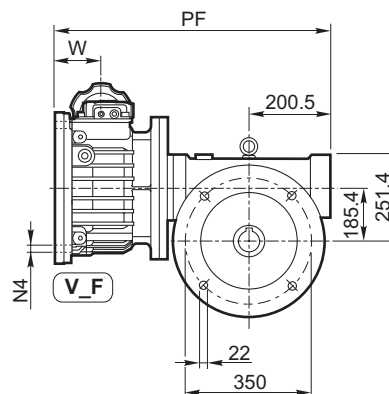
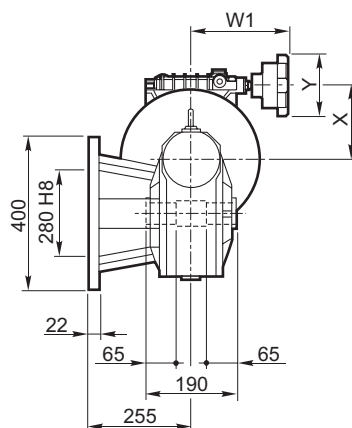

# VF 185

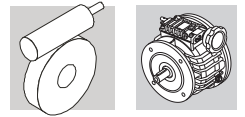

## VF 185 FC/FR + V\_P(IEC)

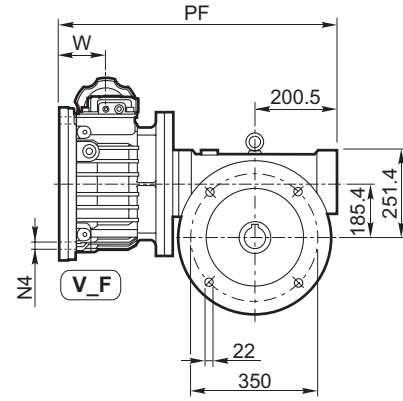
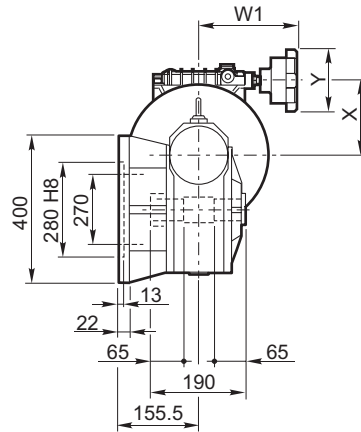

## VF 185 P + V\_P(IEC)

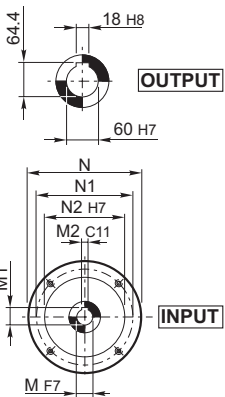
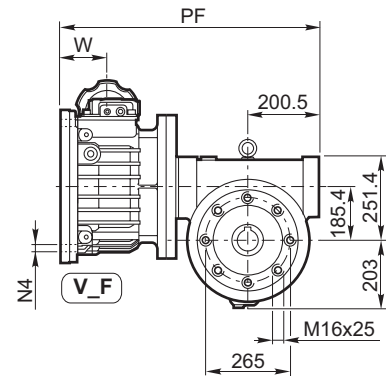
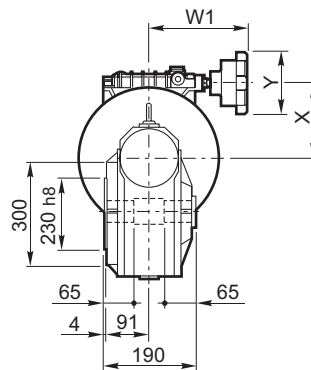

	IEC	V_C - V_F											VF185_ + V_C		VF185_ + V_F		
		N	N1	N2	N4	M	M1	M2	W	W1	X	Y	PC	kg	PF	kg	
VF 185_	V 3	P100	250	215	180	M12x23	28	31.3	8	91	172.5	150.5	109	—	—	637	133
	V 5.5	P112	250	215	180	M12x23	28	31.3	8	91	172.5	150.5	109	—	—	637	134
	V 10	P132	300	265	230	M12x25	38	41.3	10	108	193.5	206.5	109	—	—	678	191

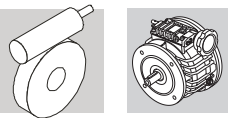

# VF 210

## VF 210 N + V\_P(IEC)

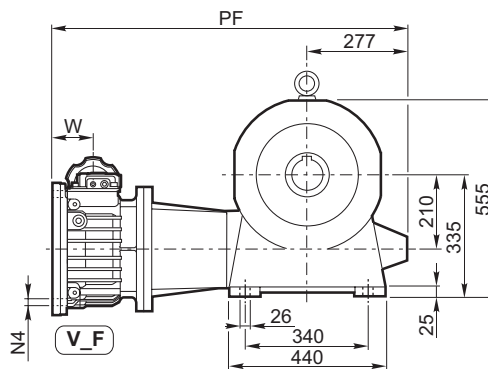
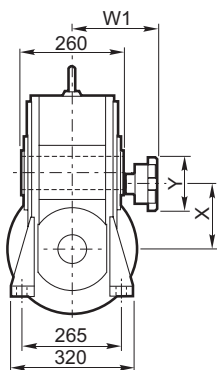

## VF 210 A + V\_P(IEC)

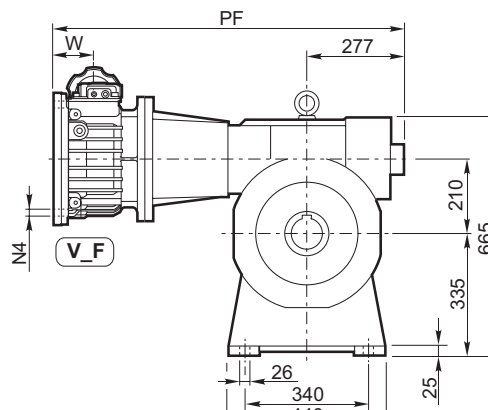
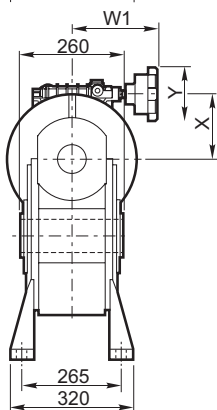

## VF 210 V + V\_P(IEC)

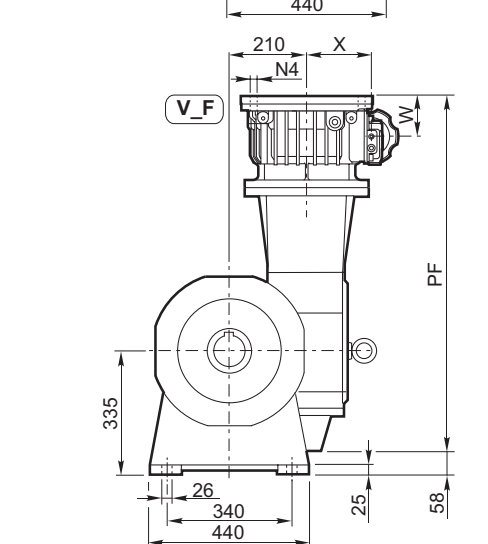
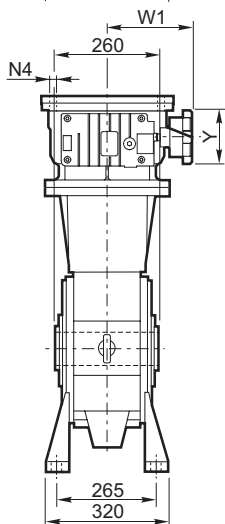

## VF 210 P + V\_P(IEC)

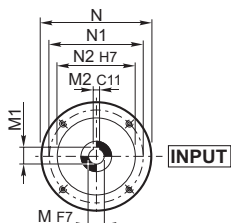
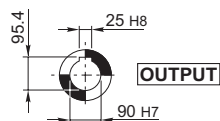
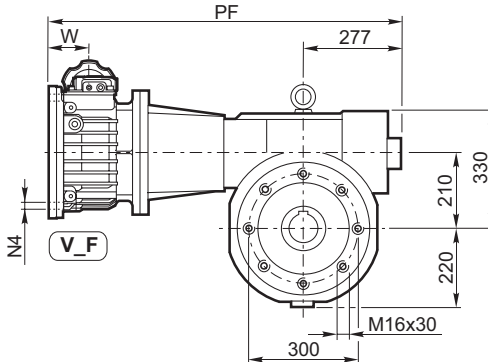
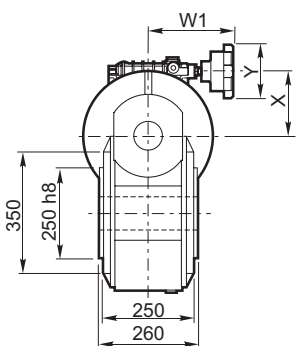

	IEC	V_C - V_F										VF210_ + V_C		VF210_ + V_F		
		N	N1	N2	N4	M	M1	M2	W	W1	X	Y	PC	kg	PF	kg
VF 210_ V 10	P132	300	265	230	M12x25	38	41.3	10	108	193.5	206.5	109	—	—	1018	307

# VF 250

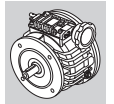
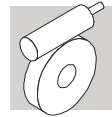

## VF 250 N + V\_P(IEC)

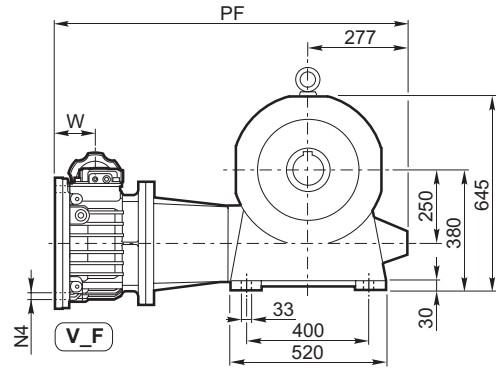
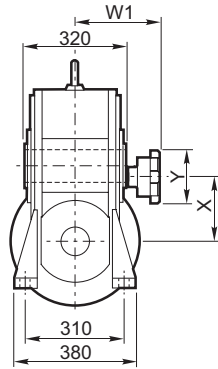

## VF 250 A + V\_P(IEC)

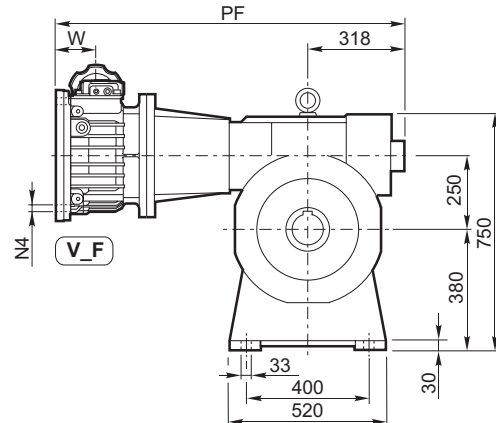
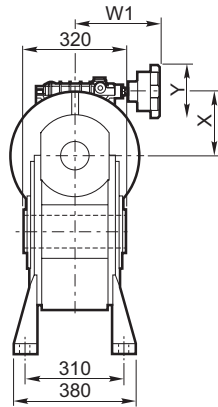

## VF 250 V + V\_P(IEC)

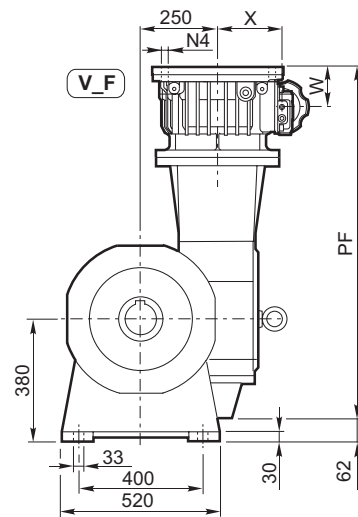
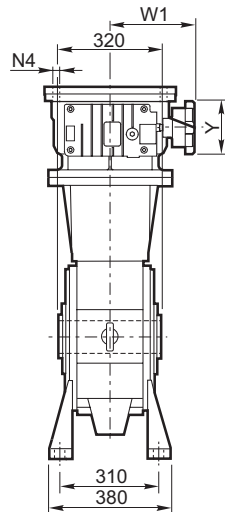

## VF 250 P + V\_P(IEC)

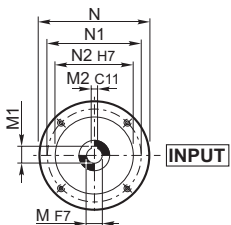
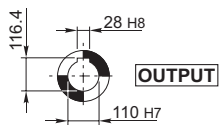
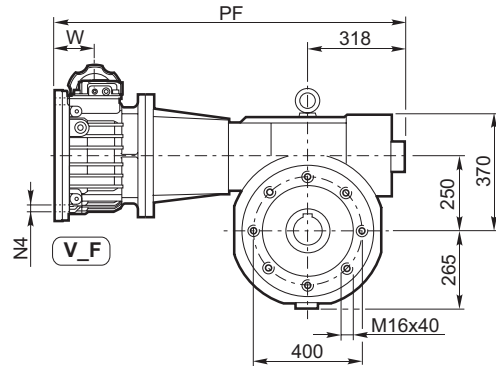
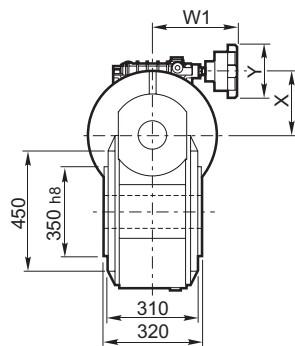

	IEC	V_C - V_F										VF250_ + V_C		VF250_ + V_F		
		N	N1	N2	N4	M	M1	M2	W	W1	X	Y	PC	kg	PF	kg
VF 250_ V 10	P132	300	265	230	M12x25	38	41.3	10	108	193.5	206.5	109	—	—	1105	407

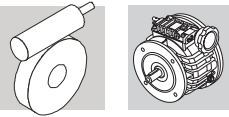

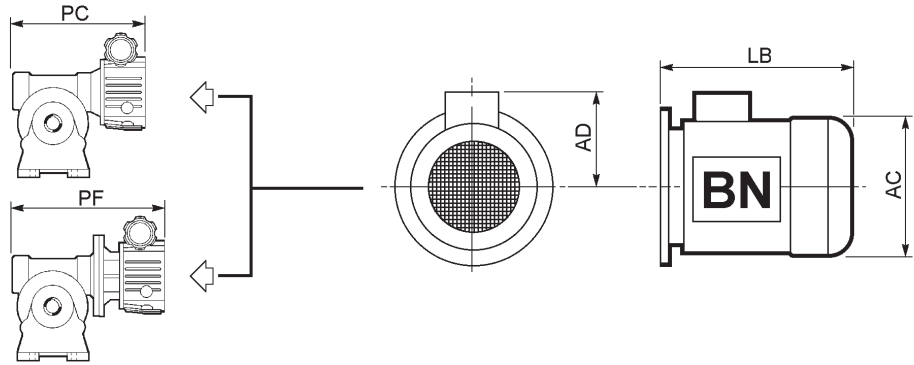

**VF\_ + V\_P + BN**

**W\_ + V\_P + BN**

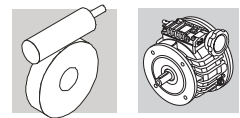

		IEC	BN			V_C		V_F	
			AC	AD	LB	PC+LB	Kg	PF+LB	Kg
VF 44_	V 0.25	63	121	95	184	387.3	10.2	411.5	10.4
	V 0.25	71R	138	108	219	387.3	11.7	411.5	11.9
VF 49_	V 0.25	63	121	95	184	405.8	11.1	425.5	11.4
	V 0.25	71R	138	108	219	405.8	12.6	425.5	12.9
	V 0.5	71	138	108	219	408.3	19.8	428	16.4
	V 0.5	80	156	119	234	412.3	19.8	432	20
	V 1	80	156	119	234	—	—	454	27
	V 1	90S	176	133	276	—	—	454	29
	V 1	90L	176	133	276	—	—	454	31
W 63_	V 0.5	71	138	108	219	474	19.1	462.5	19.7
	V 0.5	80	156	119	234	493	23	466.5	24
	V 1	80	156	119	234	508	30	495.5	31
	V 1	90S	176	133	276	550	32	495.5	33
	V 1	90L	176	133	276	550	34	495.5	35
W 75_	V 0.5	71	138	108	219	—	—	494	23
	V 0.5	80	156	119	234	—	—	498	27
	V 1	80	156	119	234	541	33	520	34
	V 1	90S	176	133	276	583	35	520	36
	V 1	90L	176	133	276	583	37	520	38
	V 2	90S	176	133	276	609	39	544	41
	V 2	90L	176	133	276	609	41	544	43
	V 2	100R	195	142	307	516.5	49	544	51
W 86_	V 0.5	71	138	108	219	—	—	523	27
	V 0.5	80	156	119	234	—	—	527	31
	V 1	80	156	119	234	570	37	548	38
	V 1	90S	176	133	276	612	39	548	40
	V 1	90L	176	133	276	612	41	548	42
	V 2	90S	176	133	276	638	43	573	45
	V 2	90L	176	133	276	638	45	573	47
	V 2	100R	195	142	307	545.5	53	573	55



		IEC	BN			V_C		V_F	
			AC	AD	LB	PC+LB		PF+LB	
W 110_	V 1	80	156	119	234	—	—	589	62
	V 1	90	176	133	276	—	—	589	64.4
	V 1	90	176	133	276	—	—	589	66.4
	V 2	90S	176	133	276	585.5	66.2	613	69.1
	V 2	90L	176	133	276	585.5	68.2	613	71.1
	V 2	100R	195	142	307	585.5	76.2	613	79.1
	V 3	100	195	142	307	748	92	813	94
	V 3	112	219	157	325	766	100	831	102
	V 5.5	112	219	157	325	766	101	831	103
VF 130_	V 2	90S	176	133	276	636.5	78.1	684	80.1
	V 2	90L	176	133	276	636.5	80.1	684	82.1
	V 2	100R	195	142	307	636.5	88.1	684	90.1
	V 3	100	195	142	307	786	108	861	110
	V 3	112	219	157	325	804	116	879	118
	V 5.5	112	219	157	325	804	117	879	119
	V 10	132S	258	193	413	—	—	1008	189
	V 10	132M	258	193	413	—	—	1008	204
VF 150_	V 3	100	195	142	307	841	119	891	121
	V 3	112	219	157	325	859	126	909	129
	V 5.5	112	219	157	325	859	127	909	130
	V 10	132S	258	193	413	—	—	1038	200
	V 10	132M	258	193	413	—	—	1038	215
VF 185_	V 3	100	195	142	307	—	—	944	155
	V 3	112	219	157	325	—	—	962	163
	V 5.5	112	219	157	325	—	—	962	164
	V 10	132S	258	193	413	—	—	1091	234
	V 10	132M	258	193	413	—	—	1091	249
VF 210_	V 10	132S	258	193	413	—	—	1431	350
	V 10	132M	258	193	413	—	—	1431	365
VF 250_	V 10	132S	258	193	413	—	—	1518	450
	V 10	132M	258	193	413	—	—	1518	465

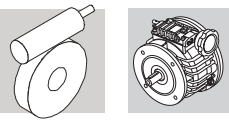

**VF\_ + V\_**

**W\_ + V\_**

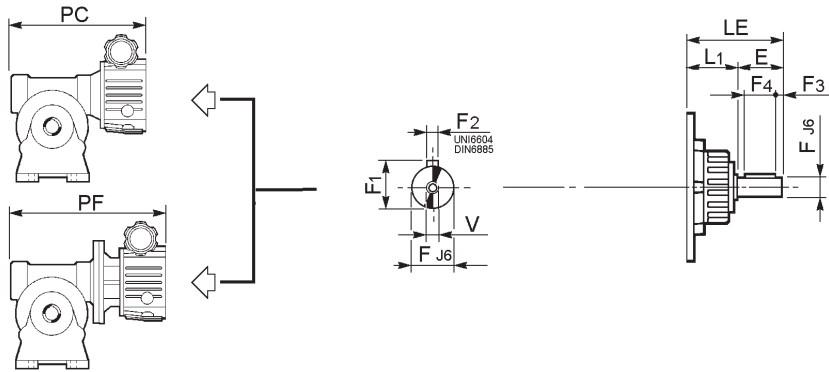

**HS**

	E	F	F1	F2	F3	F4	LE	L1	V	
<b>V 0.25</b>	23	11	12.5	4	2	20	58.5	35.5	M4	1.1
<b>V 0.5</b>	30	14	16	5	2.5	25	67	37	M5	1.6
<b>V 1</b>	40	19	21.5	6	5	30	88.5	48.5	M6	2.8
<b>V 2</b>	50	24	27	8	5	40	103.5	53.5	M8	4.0
<b>V 3</b>	60	28	31	8	5	50	121.5	61.5	M10	7.0
<b>V 5.5</b>	60	28	31	8	5	50	121.5	61.5	M10	7.0
<b>V 10</b>	80	38	41	10	5	70	160.5	80.5	M12	11.0

**VF\_ + V\_**

**W\_ + V\_**

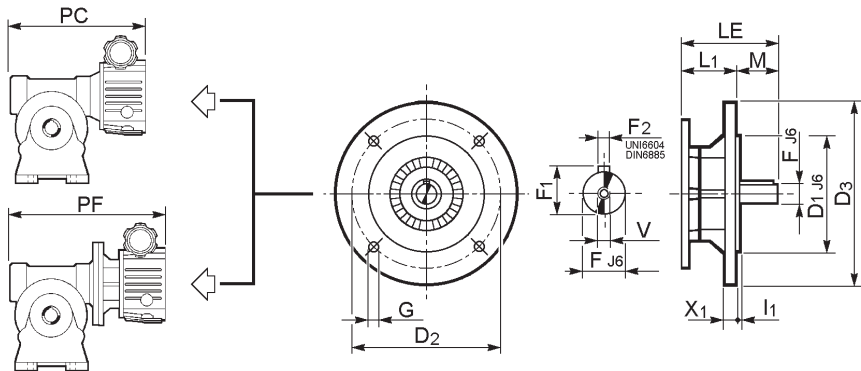

**HSF**

	D1	D2	D3	F	F1	F2	G	I1	LE	L1	M	V	X1	
<b>V 0.25</b>	95	115	140	11	12.5	4	8.5	3	58.5	37.5	21	M4	8	1.6
<b>V 0.5</b>	110	130	160	14	16	5	8.5	3.5	67	37	30	M5	8	2.5
<b>V 1</b>	130	165	200	19	21.5	6	11.5	3.5	88.5	48.5	40	M6	12	4.5
<b>V 2</b>	130	165	200	24	27	8	11.5	3.5	103.5	53.5	50	M8	12	5.9
<b>V 3</b>	180	215	250	28	31	8	14	4	121.5	61.5	60	M10	14	11.0
<b>V 5.5</b>	180	215	250	28	31	8	14	4	121.5	61.5	60	M10	14	11.0
<b>V 10</b>	230	265	300	38	41	10	14	5	160.5	80.5	80	M12	16	20

**VF\_ + V\_**

**W\_ + V\_**

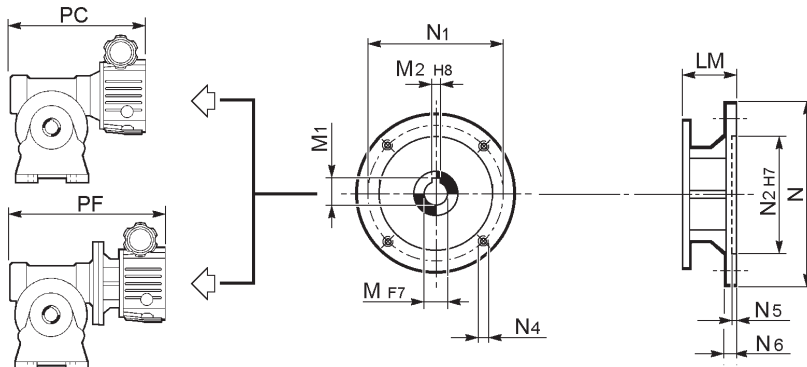

**G**

	LM	M	M1	M2	N	N1	N2	N4	N5	N6	
<b>V 0.25_G71</b>	42	14	16.3	5	160	130	110	M8	4.5	11	1.8
<b>V 0.5_G80</b>	54	19	21.8	6	200	165	130	M10	4.5	11.5	2.8
<b>V 1_G90</b>	59	24	27.3	8	200	165	130	M10	4.5	11.5	5.0
<b>V 2_G112</b>	67	28	31.3	8	250	215	180	M12	5	14	6.8
<b>V 3_G132</b>	88.5	38	41.3	10	300	265	230	M12	5	15	12.0
<b>V 5.5_G132</b>	88.5	38	41.3	10	300	265	230	M12	5	15	12.0
<b>V 10_G160</b>	120	42	45.3	12	350	300	250	M16	6	18	22

N.B. I pesi riportati in questa pagina si riferiscono alle sole entrate.

NOTE: Weights reported in this page refer to input module.

HINWEIS: Die in dieser Tabelle angegebenen Gewichte beziehen sich nur auf den Antrieb.

N.B. : Les poids indiqués à cette page se réfèrent uniquement aux entrées.



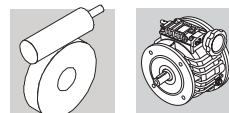

## VD\_F\_P(IEC)

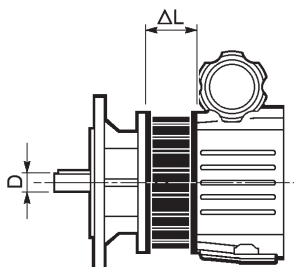

N.B. Le dimensioni mancanti sono riportate nelle pagine 260-278.

*Note: missing dimensions are indicated on pages 260-278.*

ACHTUNG: Die fehlenden Maße werden auf den Seiten 260-278 angegeben.

*N.B. : Les dimensions manquantes sont indiquées pages 260-278.*

	D	ΔL	$\text{Kg}$
<b>VD 0.5_P_</b>	14	69	3.1
<b>VD 1_P_</b>	19	80.5	4.7
<b>VD 2_P_</b>	24	89.5	7.7
<b>VD 3_P_</b>	28	100.4	16.3
<b>VD 5.5_P_</b>	28	100.4	16.3
<b>VD 10_P_</b>	38	119.2	27.7

N.B. Il differenziale è applicabile esclusivamente ai variatori nella forma costruttiva UF. I pesi riportati in tabella si riferiscono al solo differenziale.

*NOTE: Differential will only fit UF variators. Weights refer to differential alone.*

HINWEIS: Das Differential kann ausschließlich nur an den Verstellgetrieben der Bauform UF appliziert werden. Die in dieser Tabelle angegebenen Gewichte beziehen sich nur auf das Differential.

*N.B. : Le différentiel est applicable uniquement aux variateurs dans la forme de construction UF. Les poids indiqués à cette page se réfèrent uniquement au différentiel.*

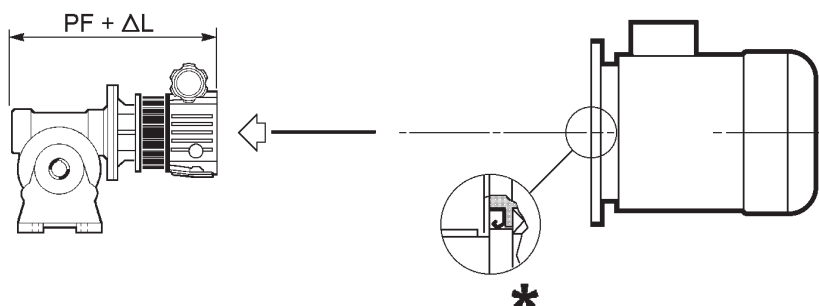

\* Nei variatori con differenziale, quando il motore elettrico è installato dall'utente, è necessario verificare che esso sia dotato di un anello di tenuta olio sull'albero montato secondo lo schema e che la flangia sia stagna. La tenuta olio fra la flangia motore e la flangia variatore è assicurata da una guarnizione fornita di serie sul variatore stesso.

*\* On fitting the electric motor onto variators featuring the differential unit make sure that the electric motor itself is oiltight and an oil seal is provided on drive end shaft. Sealing between flange of motor and variator is ensured by a gasket provided with the variator unit.*

\* Wenn der Elektromotor vom Kunden angebaut wird, ist es bei den Verstellgetrieben mit Differential erforderlich, die Motorwelle mit einem öldichten Wellendichtring auszustatten. Die Abdichtung zwischen Motor- und Verstelltriebflansch wird durch eine Dichtung gewährleistet, die beim Verstellgetriebe serienmäßig mitgeliefert wird.

*\* Sur les variateurs avec différentiel, lorsque le moteur électrique est installé par l'utilisateur, il est nécessaire de vérifier qu'il soit doté d'une bague d'étanchéité sur l'arbre monté selon le schéma. L'étanchéité à l'huile entre la bride moteur et la bride variateur est assurée par un joint fourni de série et présent sur le variateur.*

N.B. Le dimensioni e i pesi dei motori elettrici sono riportati nelle pag. 338-356.

*N.B. Dimensions and weights of electric motors are listed at page 338-356.*

ACHTUNG: Die Maße und Gewichte der Elektromotoren werden auf den Seiten 338-356 aufgeführt.

*N.B. : Les dimensions et les poids des moteurs électriques sont indiqués à pages 338-356.*

### Accessori:

- CGY
- KITCGY
- ENTHS
- ENTG
- ENTN
- INDGRAV

Vedi pag. 88-94

### Accessories:

- CGY
- KITCGY
- ENTHS
- ENTG
- ENTN
- INDGRAV

See page 88-94

### Zubehör:

- CGY
- KITCGY
- ENTHS
- ENTG
- ENTN
- INDGRAV

Siehe Seite 88-94

### Accessoires:

- CGY
- KITCGY
- ENTHS
- ENTG
- ENTN
- INDGRAV

Voir page 88-94

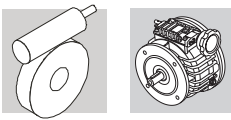

23.10 - ACCESSORI

23.10 - ACCESSORIES

23.10 - ZUBEHÖR

23.10 - ACCESSORIES

Albero lento riportato

Plug-in output shaft

Ausgangsteckwelle

Arbre lent rapporté

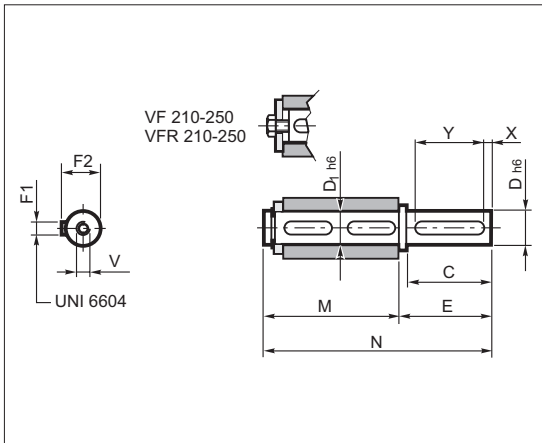

		C	D	D1	E	F1	F2	M	N	V	X	Y
VF	44	40	18	18	45	6	20.5	70	115	M6x16	5	30
	49	60	25	25	65	8	28	89	154	M8x19	5	50
W	63	60	25	25	65	8	28	127	192	M8x19	5	50
	75_D28	60	28	30	65	8	31	134	199	M8x20	5	50
	75_D30	60	30	30	65	8	33	134	199	M10x22	5	50
	86	60	35	35	65	10	38	149	214	M10x22	5	50
	110	75	42	42	80	12	45	164	244	M12x28	7.5	60
VF	130	80	45	45	85	14	48.5	176	261	M12x32	5	70
	150	85	50	50	93	14	53.5	185	278	M16x40	7.5	70
	185	100	60	60	110	18	64	200	310	M16x40	10	80
	210	130	90	90	140	25	95	255	395	M20x50	5	120
	250	165	110	110	175	28	116	315	490	M24x64	15	140

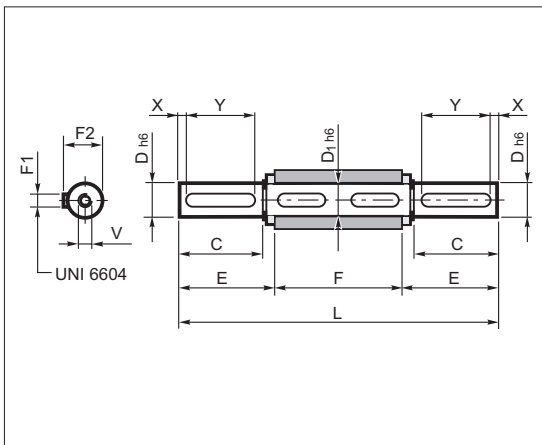

		C	D	D1	E	F	F1	F2	L	V	X	Y
VF	44	40	18	18	42.7	64	6	20.5	149.4	M6x16	5	30
	49	60	25	25	63.2	82	8	28	208.4	M8x19	5	50
W	63	60	25	25	63.2	120	8	28	246.4	M8x19	5	50
	75_D28	60	28	30	64	127	8	31	255	M8x20	5	50
	75_D30	60	30	30	64	127	8	33	255	M10x22	5	50
	86	60	35	35	64	140	10	38	268	M10x22	5	50
	110	75	42	42	79.3	155	12	45	313.5	M12x28	7.5	60
VF	130	80	45	45	84.7	165	14	48.5	334.5	M12x32	5	70
	150	85	50	50	90	175	14	53.5	355	M16x40	7.5	70
	185	100	60	60	105	190	18	64	400	M16x40	10	80
	210	130	90	90	140	260	25	95	540	M20x50	5	120
	250	165	110	110	175	320	28	116	670	M24x64	15	140

Braccio di reazione

Torque arm

Drehmomentstütze

Bras de réaction

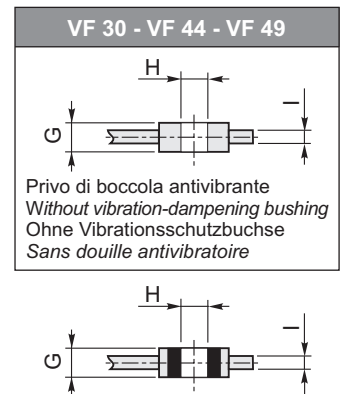
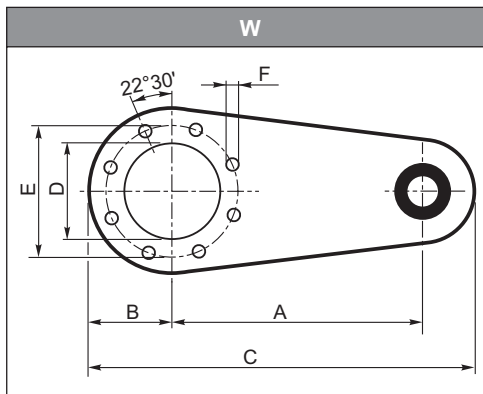
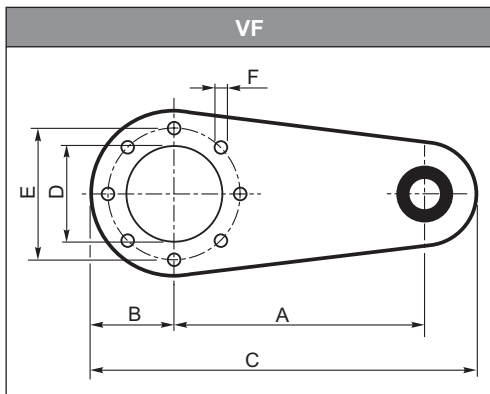

		A	B	C	D	E	F	G	H	I
VF	44	100	40	157.5	50	65	7	14	8	4
	49	100	55	172.5	68	94	7	14	8	4
W	63	150	55	233	75	90	9	20	10	6
	75	200	63	300	90	110	9	25	20	6
	86	200	80	318	110	130	11	25	20	6
	110	250	100	388	130	165	13	25	20	6
VF	130	300	125	470	180	215	13	30	25	6
	150	300	125	470	180	215	15	30	25	6
	185	350	150	545	230	265	17	30	25	6
	210	350	175	625	250	300	19	60	50	8
	250	400	225	725	350	400	19	60	50	10

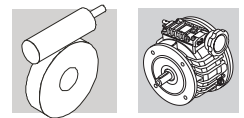

Kit piedi KA, KV

VF-interchangeable foot Kits  
KA, KV

Satz – Stützfüße KA, KV

Kit pieds KA, KV

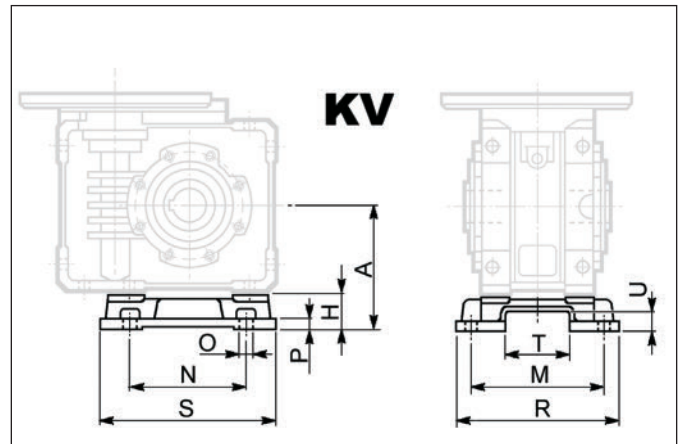
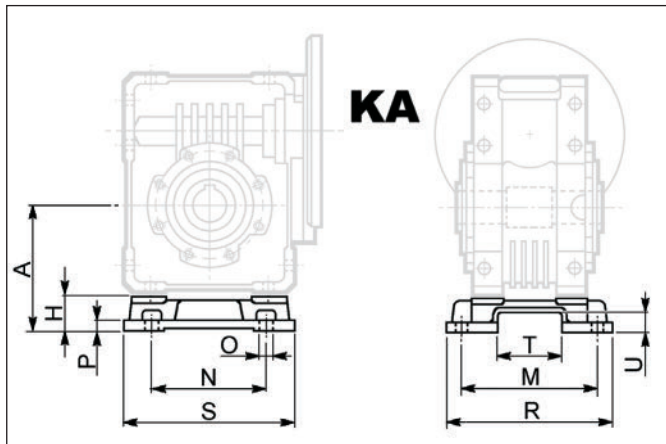

	A	H	M	N	O	P	R	S	T	U
<b>W 63</b>	100	27.5	111	95	11	8	135	145	56.5	15.5
<b>W 75</b>	115	28	115	120	11	9	139	174	56.5	15.5
<b>W 86</b>	142	42	146	140	11	11	170	200	69	20
<b>W 110</b>	170	45	181	200	13	14	210	250	69	20

Cappello di protezione

Safety cover

Schutzdeckel

Capuchon de protection

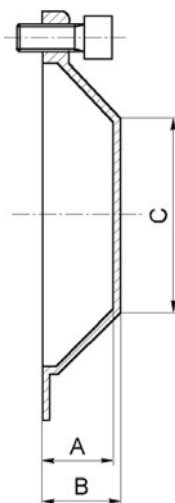

	A	B	C
<b>W 63</b>	26.5	29	Ø35
<b>W 75</b>	24.5	27	Ø54
<b>W 86</b>	26.5	29	Ø71
<b>W 110</b>	27.5	30	Ø89

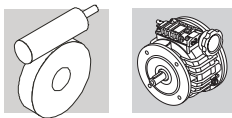

### 23.11 - Perno macchina

Nel realizzare l'albero condotto che si accoppierà con il riduttore consigliamo di utilizzare acciaio di buona qualità e di realizzare le dimensioni come suggerito nello schema seguente. Sugeriamo inoltre di completare il montaggio con un dispositivo che realizza il bloccaggio assiale dell'albero (non illustrato). Il numero e la dimensione del/i relativi fori filettati all'estremità dell'albero saranno determinati dalle diverse esigenze applicative.

### 23.11 - Customer' shaft

*Pivot of driven equipment should be made from high grade alloy steel. Table below shows recommended dimensions for the Customer to consider when designing mating shaft. A device retaining the shaft axially is also recommended (not shown). The number and size of relative tapped holes at shaft end depend on application requirements.*

### 23.11 - Maschinachse

Für die mit dem Getriebe verbundene Antriebswelle, wird empfohlen, hochwertigen Stahl zu verwenden und die im folgenden Schema enthaltenen Abmessungen zu beachten. Es wird außerdem empfohlen, die Montage mit Hilfe einer Vorrichtung, die die Welle axial blockiert (nicht abgebildet), vorzunehmen. Die Anzahl und die Abmessung des/der Gewindebohrungen an den Wellenenden werden den Einsatzbedingungen gemäß festgelegt.

### 23.11 - Arbre machine

*Pour la réalisation de l'arbre mené d'accouplement avec le réducteur, nous conseillons d'utiliser de l'acier de bonne qualité et de respecter les dimensions indiquées sur le schéma suivant. Il est recommandé de compléter le montage par un dispositif de blocage axial de l'arbre (non illustré). Le nombre et les dimensions de(s) l'orifice(s) fileté(s) correspondant(s) à l'extrémité de l'arbre sont déterminés par les différentes exigences d'application.*

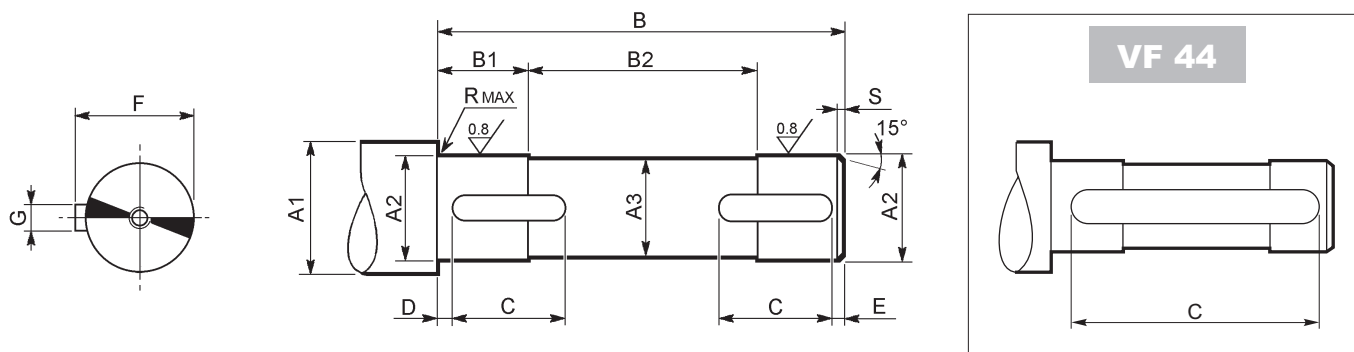

	A1	A2	A3	B	B1	B2	C	D	E	F	G	R	S	UNI 6604
<b>VF 44</b>	≥ 23	18 f7	17	62	22.5	17	50	6	6	20.5	6 h9	0.5	1.5	6x6x50 A
<b>VF 49</b>	≥ 30	25 f7	24	80	20.5	39	20	2	2	28	8 h9	1	1.5	8x7x20 A
<b>W 63</b>	≥ 30	25 f7	24	118	38	42	35	2	2	28	8 h9	1	1.5	8x7x35 A
<b>W 75</b>	≥ 35	28 f7	27	125	38	49	40	2	2	31	8 h9	1	1.5	8x7x40 A
	≥ 35	30 f7	29	125	38	49	40	2	2	33	8 h9	1	1.5	8x7x40 A
<b>W 86</b>	≥ 42	35 f7	34	138	43	52	40	2	2	38	10 h9	1.5	1.5	10x8x40 A
<b>W 110</b>	≥ 48	42 f7	41	153	43	67	50	2	2	45	12 h9	1.5	2	12x8x50 A
<b>VF 130</b>	≥ 52	45 f7	44	163	50.5	62	60	2.5	2.5	49.5	14 h9	2.5	2	14x9x60 A
<b>VF 150</b>	≥ 57	50 f7	49	173	53	67	70	2.5	2.5	53.5	14 h9	2.5	2	14x9x70 A
<b>VF 185</b>	≥ 68	60 f7	59	188	63	62	80	2.5	2.5	64	18 h9	2.5	2	18x11x80 A
<b>VF 210</b>	≥ 99	90 f7	89	258	83	92	80	3	3	95	25 h9	2.5	2.5	25x14x80 A
<b>VF 250</b>	≥ 121	110 h7	109	318	83	152	80	3	3	116	28 h9	2.5	2.5	28x16x80 A

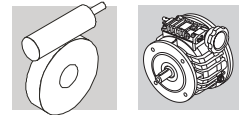

### 23.12 - Limitatore di coppia

### 23.12 - Torque limiter

### 23.12 - Rutschkupplung

### 23.12 - Limiteur de couple

Il limitatore di coppia a frizione è studiato e realizzato per i riduttori senza fine VF44, VF49 e W63...W110, è un dispositivo di protezione atto a salvaguardare la trasmissione da sovraccarichi accidentali che potrebbero danneggiare tutti gli elementi della trasmissione creando seri inconvenienti alla macchina operatrice.

The friction-based torque limiter, available for wormgears type VF44, VF49 and W63...W110, is designed to protect the transmission from accidental overloads which could damage the drive elements.

Die Rutschkupplung, die für Schneckengetriebe VF44, VF49 und W63...W110, entwickelt wurde, dient dem Schutz des Getriebes vor zufälligen Überlastungen, welche die Antriebselemente zerstören könnten.

Le limiteur de couple à friction, étudié et réalisé pour les réducteurs à vis sans fin, type VF44, VF49 et W63...W110, est un dispositif de sécurité qui a pour but de protéger la chaîne cinématique des surcharges accidentelles qui pourraient endommager tous les éléments de la transmission.



Se ne sconsiglia l'utilizzo in meccanismi di sollevamento.



We advise against installing this device to lifting equipment.



Von einer Montage in Hebe-  
mechanismen wird abgeraten.



Son utilisation dans des mécanismes de levage est déconseillée.

L1							
	N	A	V	U	F1 FC1 FR1 FA1	F2 FC2 FR2 FA2*	P1 P2
VF						 *VF 49	
	U	UF1 UFC1	UF2 UFC2	UF1CR1	UF1CR2		
W							

L2							
	N	A	V	U	F1 FC1 FR1 FA1*	F2 FC2 FR2 FA2	P1 P2
VF						 *VF 49	
	U	UF1 UFC1	UF2 UFC2	UF1CR1	UF1CR2		
W							

Se non preventivamente specificato, i riduttori VF...L verranno forniti con la ghiera a sinistra (L1) guardando il motore elettrico in posizione di montaggio B3.

Unless otherwise specified VF...L gear units are supplied with ring nut on the left hand side (L1), viewing from the electric motor and gearbox in the B3 mounting position.

Wenn nicht anders angegeben, werden die Getriebe VF...L geliefert mit der Verstellmutter links (L1), mit Sicht auf den E-Motor.

En standard et en l'absence d'information précise, les réducteurs VF...L seront livrés avec le système de décrabotage à gauche (L1), vue se plaçant du côté du moteur électrique.

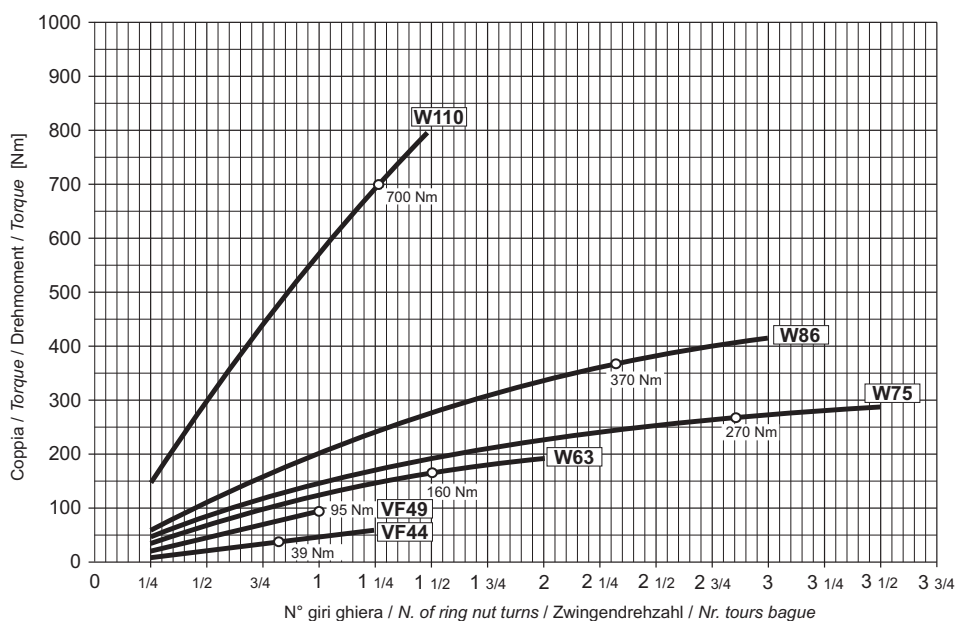

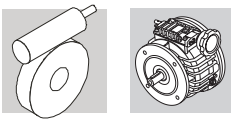

**Dimensioni**

**Dimensions**

**Abmessungen**

**Dimensions**

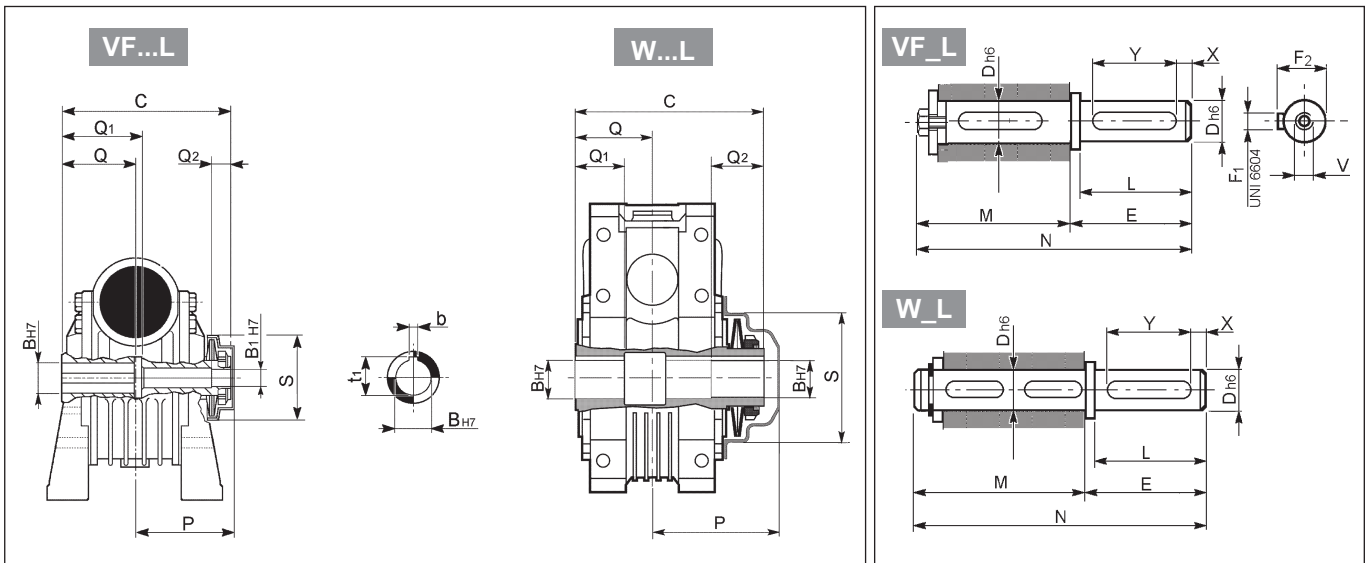

	Limitatore di coppia / Torque limiter Rutschkupplung / Limiteur de couple										Albero lento semplice / Single output shaft Ein freies Wellenende / Arbre lent unilateral									
	C	Q	Q1	Q2	P	S	B	B1	t1	b	L	D	E	F1	F2	M	N	V	X	Y
<b>VF 44L</b>	79	32	32	12	48	42.5	18	11	20.8	6	40	18	45	6	20.5	86	131	M6x16	5	30
<b>VF 49L</b>	105	41	51	15	63.5	66.5	25	14	28.3	8	60	25	65	8	28	114.5	179.5	M8x19	5	40
<b>W 63L</b>	145	60	40	40	100	77	25	-	28.3	8	60	25	65	8	28	152	217	M8x19	5	50
<b>W 75L_D30</b>	154.5	63.5	40	40	104	100	30	-	33.3	8	60	30	65	8	33	161.5	226.5	M10x22	5	50
<b>W 86L</b>	170	70	50	45	113	119	35	-	38.3	10	60	35	65	10	38	179	244	M10x22	5	50
<b>W 110L</b>	191	77.5	55	45	133	134	42	-	45.3	12	75	42	80	12	45	200	280	M12x28	7.5	60

**Lubrificazione**

Nei riduttori con limitatore di coppia incorporato viene adottata la lubrificazione permanente con olio sintetico, questo permette l'installazione in tutte le posizioni di montaggio. Il giusto riempimento viene eseguito all'atto del montaggio. Nella tabella seguente vengono indicate le quantità di lubrificante contenute nei riduttori serie VF...L e W...L. Dopo lunghe e severe prove effettuate presso la ns. Sala Esperienze abbiamo verificato che la lubrificazione a grasso dei gruppi con limitatore di coppia non è consigliata. I migliori risultati e prestazioni si ottengono utilizzando olio sintetico: SHELL OMALA S4 WE 460. Questo lubrificante può essere impiegato per temperatura ambiente da -15 °C a +50°C.

**Lubrication**

*Gear units featuring the torque-limiter device are factory lubed "for life" with synthetic oil. Units are factory filled with the appropriate quantity of oil, allowing installation in any mounting position. See following table for reference.*  
*Notice: Thorough testing conducted by the R & D Dept. demonstrates that lubrication requirements of the torque limiter device are not fulfilled by grease.*  
*Best results are achieved by the synthetic-base oil: SHELL OMALA S4 WE 460. Above lubricant allows operation within an ambient temperature range of -15°C — +50°C.*

**Schmierung**

In Schneckengetrieben mit Rutschkupplung erfolgt eine Dauerschmierung mit synthetischem Öl. Alle Einbaulagen sind möglich. Die Füllung mit der richtigen Menge erfolgt während der Montage. Die folgende Tabelle stellt die erforderlichen Schmiermittelmengen, der Serie VF...L und W...L, dar. Langere und gründliche Untersuchungen unserer Entwicklungsabteilung haben ergeben, dass eine Fettschmierung der Getriebe mit Rutschkupplung nicht ratsam ist. Die besten Ergebnisse wurden von uns mit dem synthetischen Öl: SHELL OMALA S4 WE 460 erzielt. Dieses Schmiermittel kann bei Umgebungstemperaturen von -15 °C bis + 50° C verwendet werden.

**Lubrification**

*Dans les réducteurs à limiteur de couple incorporé, la lubrification à vie à l'huile synthétique a été adoptée. Ceci permet l'installation du groupe dans toutes les positions de montage. Le remplissage avec la bonne quantité de huile est effectué au moment du montage du réducteur. Dans le tableau suivant sont indiqués les quantités de lubrifiant prévues dans le réducteur VF...L et W...L. Après de longs et sévères essais effectués auprès de notre département recherche et développement nous avons vérifié que la lubrification à la graisse des groupes avec limiteur de couple n'est pas la plus adaptée. Les meilleurs résultats et prestations s'obtiennent en utilisant une huile synthétique SHELL OMALA S4 WE 460. Ce lubrifiant peut être employé pour des températures ambiantes de -15 °C a + 50°C.*

Lubrificazione a olio (litri) Oil lubrication (litres) Öl-Schmierung (liter) Lubrification à l'huile (litres)	VF 44L	VF 49L	W 63L	W 75L	W 86L	W 110L
	0.075	0.12	0.31	0.48	0.64	1.5

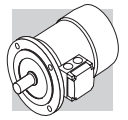

---

**MOTORI ELETTRICI**  
***ELECTRIC MOTORS***  
**ELEKTROMOTOREN**  
***MOTEURS ELECTRIQUES***

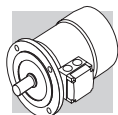

SIMBOLOGIA E UNITÀ DI MISURA		SYMBOLS AND UNITS OF MEASURE		SYMBOLS UND MAßEINHEITEN		SYMBOLS ET UNITES DE MESURE	
Symb.	U.m.	Descrizione	Description	Beschreibung	Description	Symb.	U.m.
$\cos\phi$	–	Fattore di potenza	Power factor	Leistungsfaktor	Facteur de puissance		
$\eta$	–	Rendimento	Efficiency	Wirkungsgrad	Rendement		
$f_m$	–	Fattore correttivo della potenza	Power adjusting factor	Leistungskorrekturfaktor	Facteur de correction de la puissance		
$I$	–	Rapporto di intermittenza	Cyclic duration factor	Relative Einschaltdauer	Rapport d'intermittence		
$I_N$	[A]	Corrente nominale	Rated current	Nennstrom	Courant nominal		
$I_S$	[A]	Corrente di spunto	Locked rotor current	Kurzschlußstrom	Courant de démarrage		
$J_C$	[Kgm <sup>2</sup> ]	Momento di inerzia del carico	Load moment of inertia	Massenträgheitsmoment der externen Massen	Moment d'inertie de la charge		
$J_M$	[Kgm <sup>2</sup> ]	Momento di inerzia motore	Moment of inertia	Trägheitsmoment	Moment d'inertie du moteur		
$K_c$	–	Fattore di coppia	Torque factor	Drehmomentfaktor	Facteur de couple		
$K_d$	–	Fattore di carico	Load factor	Lastfaktor	Facteur de charge		
$K_J$	–	Fattore di inerzia	Inertia factor	Trägheitsfaktor	Facteur d'inertie		
$M_A$	[Nm]	Coppia accelerante media	Mean breakaway torque	Losbrechmoment	Couple d'accélération moyen		
$M_B$	[Nm]	Coppia frenante	Brake torque	Bremsemoment	Couple du frein		
$M_N$	[Nm]	Coppia nominale	Rated torque	Nennmoment	Couple nominal		
$M_L$	[Nm]	Coppia resistente media	Counter-torque during acceleration	Lastmoment	Couple résistant moyen		
$M_S$	[Nm]	Coppia di spunto	Starting torque	Startmoment	Couple de démarrage		
$n$	[min <sup>-1</sup> ]	Velocità nominale	Rated speed	Nendrehzahl	Vitesse nominale		
$P_B$	[W]	Potenza assorbita dal freno a 20°C	Power drawn by the brake at 20°C	Leistungsaufnahme der Bremse bei 20°C	Puissance absorbée par le frein à 20°C		
$P_n$	[kW]	Potenza nominale	Motor rated power	Nennleistung	Puissance nominale		
$P_r$	[kW]	Potenza richiesta	Required power	Benötigte Leistung	Puissance nécessaire		
$t_1$	[ms]	Ritardo di sblocco del freno con alimentatore a semionda	Brake response time with one-way rectifier	Ansprechzeit Bremse mit Einweg-Gleichrichter	Temps de déblocage du frein avec alimentation à demi-onde		
$t_{1s}$	[ms]	Tempo di sblocco del freno con alimentatore a controllo elettronico	Brake response time with electronic-controlled rectifier	Ansprechzeit Bremse mit elektronisch gesteuertem Gleichrichter	Temps de déblocage du frein avec alimentation à contrôle électronique		
$t_2$	[ms]	Ritardo di frenatura con disgiunzione lato c.a.	Brake reaction time with a.c. disconnect	Einfallszeit Bremse bei Unterbrechung der Stromversorgung WS	Retard de freinage avec coupure coté c.a.		
$t_{2c}$	[ms]	Ritardo di frenatura con disgiunzione circuito c.a. e c.c.	Brake reaction time with a.c. and d.c. disconnect	Einfallszeit Bremse bei Unterbrechung der Stromversorgung WS und GS	Retard de freinage avec coupure coté c.a. et c.c.		
$t_a$	[°C]	Temperatura ambiente	Ambient temperature	Umgebungstemperatur	Température ambiante		
$t_f$	[min]	Tempo di funzionamento a carico costante	Work time at constant load	Betriebsdauer unter Nennbelastung	Temps de fonctionnement à charge constante		
$t_r$	[min]	Tempo di riposo	Rest time	Aussetzzeit	Temps de repos		
$W$	[J]	Lavoro di frenatura accumulato tra due regolazioni del traferro	Braking work between service	Bremsenergie zwischen zwei Einstellungen	Energie de freinage accumulée entre deux réglages de l'entrefer		
$W_{max}$	[J]	Energia massima per singola frenatura	Maximum brake work for each braking	Max. Bremsarbeit pro Bremsvorgang	Energie maxi par freinage		
$Z$	[1/h]	N° di avviamenti ammissibili, a carico	Permissible starting frequency, loaded	Schalhäufigkeit Nennbetrieb	Nombre de démarrages admissibles en charge		
$Z_0$	[1/h]	N° di avviamenti ammissibili a vuoto (I = 50%)	Max. permissible no-load starting frequency (I = 50%)	Max. Schalhäufigkeit im Leerlauf (relative Einschalt-dauer I = 50%)	Nombre de démarrages admissible à vide (I = 50%)		





## M1 - PROGRAMMA DI PRODUZIONE

Questo catalogo descrive i motori asincroni trifase in bassa tensione di produzione BONFIGLIOLI RIDUTTORI.

I motori sono del tipo chiuso con ventilazione esterna e rotore a gabbia per l'utilizzo in ambienti industriali.

## M1 - PRODUCTION PLANNING

*This catalogue discusses low-voltage three-phase asynchronous motors manufactured by BONFIGLIOLI RIDUTTORI.*

*Motors are the enclosed type with outer fan and cage-type rotor for use in industrial environments.*

## M1 - PRODUKTIONSPROGRAMM

In diesem Katalog werden die unter Niederspannung arbeitenden asynchronen Drehstrommotoren der Produktion von BONFIGLIOLI RIDUTTORI näher beschrieben. Hierbei handelt es sich um geschlossene Motoren mit Eigenbelüftung und einem Käfigrotor für den industriellen Einsatz.

## M1 - PROGRAMME DE PRODUCTION

*Ce catalogue décrit les moteurs asynchrones triphasés en basse tension produits par BONFIGLIOLI RIDUTTORI.*

*Les moteurs sont du type fermé avec ventilation extérieure et rotor à cage pour l'utilisation dans des milieux industriels.*

## M2 - NORMATIVE

I motori sono costruiti in accordo alle Norme CEI/EN ed IEC applicabili, riportate in tabella.

## M2 - REFERENCE STANDARDS

*Motors are manufactured in accordance with applicable CEI /EN and IEC standards, listed in the table.*

## M2 - NORMEN

Die Motoren wurden in entsprechender Normen CEI /EN und IEC, die in der nachstehenden Tabelle angegeben sind, gefertigt:

## M2 - NORMES

*Les moteurs sont fabriqués dans le respect des Normes CEI /EN et IEC applicables indiquées dans le tableau.*

(01)

Titolo / Title / Titel / Titre	CEI	IEC
Prescrizioni generali per macchine elettriche rotanti <i>General requirements for rotating electrical machines</i> Allgemeine Vorschriften für umlaufende elektrische Maschinen <i>Prescriptions générales pour machines électriques tournantes</i>	CEI EN 60034-1	IEC 60034-1
Marcatura dei terminali e senso di rotazione per macchine elettriche rotanti <i>Terminal markings and direction of rotation of rotating machines</i> Kennzeichnung der Anschlußklemmen und Drehrichtung von umlaufenden elektrischen Maschinen <i>Définitions des bornes et sens de rotation pour machines électriques tournantes</i>	CEI 2-8	IEC 60034-8
Metodi di raffreddamento delle macchine elettriche <i>Methods of cooling for electrical machines</i> Verfahren zur Kühlung von elektrischen Maschinen <i>Méthodes de refroidissement des machines électriques</i>	CEI EN 60034-6	IEC 60034-6
Dimensioni e potenze nominali per macchine elettriche rotanti <i>Dimensions and output ratings for rotating electrical machines</i> Auslegung der Nennleistung von umlaufenden elektrischen Maschinen <i>Dimensions, puissances nominales pour machines électriques tournantes</i>	EN 50347	IEC 60072
Classificazione dei gradi di protezione delle macchine elettriche rotanti <i>Classification of degree of protection provided by enclosures for rotating machines</i> Klassifizierung der Schutzart von umlaufenden elektrischen Maschinen <i>Classification des degrés de protection des machines électriques tournantes</i>	CEI EN 60034-5	IEC 60034-5
Limiti di rumorosità <i>Noise limits</i> Geräuschgrenzwerte <i>Limites de bruit</i>	CEI EN 60034-9	IEC 60034-9
Sigle di designazione delle forme costruttive e dei tipi di installazione <i>Classification of type of construction and mounting arrangements</i> Abkürzungen zur Kennzeichnung der Bauform und der Einbaulagen <i>Sigles de dénomination des formes de construction et des types d'installation</i>	CEI EN 60034-7	IEC 60034-7
Tensione nominale per i sistemi di distribuzione pubblica dell'energia elettrica a bassa tensione <i>Rated voltage for low voltage mains power</i> Nennspannung für öffentliche NS-Stromverteilungssysteme <i>Tension nominale pour les systèmes de distribution publique de l'énergie électrique en basse tension</i>	CEI 8-6	IEC 60038
Grado di vibrazione delle macchine elettriche <i>Vibration level of electric machines</i> Schwingstärke bei elektrischen Maschinen <i>Degré de vibration des machines électriques</i>	CEI EN 60034-14	IEC 60034-14



I motori corrispondono inoltre alle Norme straniere elencate qui di seguito:

*Motors are also in compliance with the national Standards listed below:*

Die Motoren entsprechen darüber hinaus den nachstehend aufgelisteten ausländischen Normen:

*Les moteurs correspondent aussi aux Normes étrangères suivantes :*

(02)

<b>DIN VDE 0530</b>	Germania	<i>Germany</i>	Deutschland	<i>Allemagne</i>
<b>BS5000 / BS4999</b>	Gran Bretagna	<i>Great Britain</i>	Großbritannien	<i>Grande Bretagne</i>
<b>AS 1359</b>	Australia	<i>Australia</i>	Australien	<i>Australie</i>
<b>NBNC 51-101</b>	Belgio	<i>Belgium</i>	Belgien	<i>Belgique</i>
<b>NEK - IEC 60034-1</b>	Norvegia	<i>Norway</i>	Norwegen	<i>Norvège</i>
<b>NF C 51</b>	Francia	<i>France</i>	Frankreich	<i>France</i>
<b>OEVE M 10</b>	Austria	<i>Austria</i>	Österreich	<i>Autriche</i>
<b>SEV 3009</b>	Svizzera	<i>Switzerland</i>	Schweiz	<i>Suisse</i>
<b>NEN 3173</b>	Paesi Bassi	<i>Netherlands</i>	Niederlande	<i>Pays Bas</i>
<b>SS 426 01 01</b>	Svezia	<i>Sweden</i>	Schweden	<i>Suède</i>

**Direttive 2006/95/CE (LVD) e 2004/108/CE (EMC)**

***Directives 2006/95/EC (LVD) and 2004/108/EC (EMC)***

**Richtlinien 2006/95/EG (LVD) und 2004/108/EG (EMC)**

***Directives 2006/95/CE (LVD) et 2004/108/CE (EMC)***

I motori della serie BN sono conformi ai requisiti delle Direttive 2006/95/CE (Direttiva Bassa Tensione) e 2004/108/CE (Direttiva Compatibilità Elettromagnetica), e riportano in targa la marcatura CE. Per quanto riguarda la Direttiva EMC, la costruzione è in accordo alle Norme CEI EN 60034-1, EN 61000-6-2, EN 61000-6-4.

*BN motors meet the requirements of Directives 2006/95/EC (Low Voltage Directive) and 2004/108/EC (Electromagnetic Compatibility Directive) and their name plates bear the CE mark. As for the EMC Directive, construction is in accordance with standards CEI EN 60034-1, EN 61000-6-2, EN 61000-6-4.*

Die Motoren der Serie BN entsprechen den Anforderungen der Richtlinien 2006/95/EG (Richtlinie - Niederspannung) und 2004/108/EG (Richtlinie - elektromagnetische Kompatibilität) und sind mit dem CE-Zeichen ausgestattet.

*Les moteurs de la série BN sont conformes aux conditions requises par les Directives 2006/95/CE (Directive Basse Tension) et 2004/108/CE (Directive Compatibilité Electromagnétique), et le marquage CE est indiqué sur la plaquette signalétique. En ce qui concerne la Directive EMC, la fabrication répond aux Normes CEI EN 60034-1, EN 61000-6-2, EN 61000-6-4.*

I motori con freno in c.c. tipo FD, se corredati dell'opportuno filtro capacitivo in ingresso al raddrizzatore (opzione **CF**), rientrano nei limiti di emissione previsti dalla Norma EN 61000-6-3 "Compatibilità elettromagnetica - Norma Generica sull'emissione - Parte 1: Ambienti residenziali, commerciali e dell'industria leggera".

*Motors with FD brakes, when fitted with the suitable capacitive filter at rectifier input (option **CF**), meet the emission limits required by Standard EN 61000-6-3 "Electromagnetic compatibility - Generic Emission Standard - Part 1: Residential, commercial and light industrial environment".*

Im Hinblick auf die Richtlinie EMC entspricht die Konstruktion den Normen CEI EN 60034-1, EN 61000-6-2, EN 61000-6-4.

Die Motoren mit dem Bremstyp FD fallen, falls mit dem entsprechenden kapazitiven Filter am Eingang des Gleichrichters ausgestattet (Option **CF**), unter die Emissionsgrenzwerte, die von der Norm EN 61000-6-3 "Elektromagnetische Kompatibilität - Allgemeine Norm für Emissionen - Teil 1: Wohngebiete, Handels- und Leichtinduszriezonen" vorgesehen werden.

*Les moteurs avec frein FD, s'ils sont équipés du frein capacitif approprié en entrée du redresseur (option **CF**), rentrent dans les limites d'émission prévues par la Norme EN 61000-6-3 "Compatibilité électromagnétique - Norme Générique sur l'émission - Partie 1 : Milieux résidentiels, commerciaux et de l'industrie légère".*

I motori soddisfano inoltre le prescrizioni della Norma CEI EN 60204-1 "Equipaggiamento elettrico delle macchine".

*Motors also meet the requirements of standard CEI EN 60204-1 "Electrical equipment of machines".*

Die Motoren entsprechen darüber hinaus den von der Norm CEI EN 60204-1 "Elektrische Maschinenausstattung" gegebenen Vorschriften.

*Les moteurs répondent aussi aux prescriptions de la Norme CEI EN 60204-1 "Equipement électrique des machines".*

**È responsabilità del costruttore o dell'assemblatore dell'apparecchiatura che incorpora i motori come componenti garantire la sicurezza e la conformità alle direttive del prodotto finale.**

***The responsibility for final product safety and compliance with applicable directives rests with the manufacturer or the assembler who incorporate the motors as component parts.***

**Es liegt in der Verantwortung des Herstellers oder des Monteurs der Anlage, in der die Motoren als Komponenten montiert werden, die Sicherheit und die Übereinstimmung mit den Richtlinien des Endprodukts zu gewährleisten.**

***Le fabricant ou le monteur de la machine qui comprend les moteurs comme composant est responsable et doit se charger de garantir la sécurité et la conformité aux directives du produit final.***



### M3 - TOLLERANZE

Secondo le Norme CEI EN 60034-1 sono ammesse le tolleranze qui indicate per le grandezze garantite:

### M3 - TOLERANCES

Allowed tolerances for guaranteed parameters in accordance with standards CEI EN 60034-1 are indicated in the table below:

### M3 - TOLERANZEN

Den Normen CEI EN 60034-1 entsprechend sind für die angegebenen Werte folgende Toleranzen zulässig:

### M3 - TOLERANCES

Selon les Normes CEI EN 60034-1 les tolérances indiquées ci-dessous sont admises pour les tailles garanties :

(03)

-0.15 (1 - $\eta$ ) P ≤ 50 kW	Rendimento	Efficiency	Wirkungsgrad	Rendement
-(1 - cos $\phi$ ) / 6 min 0.02 max 0.07	Fattore di potenza	Power factor	Leistungsfaktor	Facteur de puissance
± 20% (*)	Scorrimento	Slip	Schlupf	Glissement
+ 20%	Corrente a rotore bloccato	Locked rotor current	Strom bei blockiertem Läufer	Courant à rotor bloqué
-15% + 25%	Coppia a rotore bloccato	Locked rotor torque	Drehmoment bei blockiertem Läufer	Couple à rotor bloqué
-10%	Coppia max	Max. torque	Max. Drehmoment	Couple max

(\*) ± 30% per motori con P<sub>n</sub> < 1 kW (\*) ± 30% for motors with P<sub>n</sub> < 1 kW (\*) ± 30% für Motoren mit P<sub>n</sub> < 1 kW (\*) ± 30% pour moteurs avec P<sub>n</sub> < 1 kW

### M3.1 - TOLLERANZE GEOMETRICHE

L'estremità d'albero, la linguetta e la flangia hanno dimensioni e tolleranze secondo EN 50347, IEC 60072-1, CEI-UNEL 13501. Le estremità d'albero sono previste di foro filettato in testa secondo UNI 9321, DIN 332. I motori sono sempre forniti con linguetta inserita nella sede. La tabella seguente riporta le tolleranze previste per le diverse parti:

### M3.1 - GEOMETRIC TOLERANCES

Dimensions and tolerances of shaft end, key and flange are in accordance with EN 50347, IEC 60072-1, CEI-UNEL 13501. Shaft ends feature an axial threaded hole in accordance with UNI 3221, DIN 332 and a key inserted in the suitable keyway. The following table reports the tolerances for the different parts:

### M3.1 - GEOMETRISCHE TOLERANZEN

Die Wellenenden, der Federkeil und der Flansch entsprechen im Hinblick auf ihre Maße und Toleranzen den Normen EN 50347, IEC 60072-1 und CEI-UNEL 13501. Die Wellenenden sind an ihrer Stirnseite mit einer Gewindebohrung gemäß UNI 3221, DIN 332 versehen und werden mit einem in seinen Sitz eingefügten Federkeil geliefert. In der nachstehenden Tabelle werden für die verschiedenen Teile die entsprechenden Toleranzen angegeben:

### M3.1 - TOLERANCES GEOMETRIQUES

L'extrémité de l'arbre, la clavette et la bride présentent des dimensions et tolérances selon EN 50347, IEC 60072-1, CEI-UNEL 13501. Les extrémités d'arbre sont dotées d'orifice fileté en tête, selon UNI 3221, DIN 332 ainsi que la clavette introduite dans le logement. Le tableau suivant indique les tolérances prévues pour les différentes pièces :

(04)

Componente / Component Komponente / Composant	Dimensioni / Dimensions Abmessungen / Dimensions		Tolleranza / Tolerance Tolérance / Tolérance
Estremità albero / Shaft end Wellenende / Extrémité arbre	<b>D - DA</b>	∅ 11 - 28	<b>j6</b>
		∅ 38 - 48	<b>k6</b>
		∅ ≥ 55	<b>m6</b>
Linguetta / Key Federkeil / Clavette	<b>F - FA</b>		<b>h9</b>
Flangia / Flange Flansch / Bride	<b>N</b>	∅ < 250	<b>j6</b>
		∅ ≥ 250	<b>h6</b>

### M3.2 - RUMOROSITÀ

I valori di rumorosità, rilevati secondo il metodo indicato dalle Norme ISO 1680, sono contenuti entro i livelli massimi previsti dalle Norme CEI EN 60034-9.

### M3.2 - NOISE LEVEL

Noise levels measured using the method specified by standard ISO 1680 are within the maximum limits required by standards CEI EN 60034-9.

### M3.2 - GERÄUSCHPEGEL

Der Geräuschpegel wurde entsprechend der in der Norm ISO 1680 angegebenen Methode gemessen und liegt innerhalb der max. Werte, die von der Norm CEI EN 60034-9 vorgeschrieben werden.

### M3.2 - NIVEAU DE BRUIT

Les valeurs du niveau de bruit, mesurées selon la méthode indiquée par les Normes ISO 1680 sont contenues dans les limites maximums prévues par les Normes CEI EN 60034-9.



#### M4 - SENSO DI ROTAZIONE

È possibile il funzionamento dei motori in entrambi i versi di rotazione. Con collegamento dei morsetti U1, V1, W1 alle fasi di linea L1, L2, L3 si ottiene la rotazione oraria, osservando l'albero dal lato accoppiamento. La marcia antioraria si ottiene scambiando fra loro due fasi.

#### M4 - DIRECTION OF ROTATION

Motors may operate in both directions of rotation. When the terminals U1, V1, W1 are connected to the line phases L1, L2, L3, the motor will run in a clockwise direction as viewed from the coupling end. Counter clockwise rotation is obtained by swapping two phases.

#### M4 - DREHRICHTUNG

Die Motoren können in beiden Drehrichtungen betrieben werden. Schließt man die Klemmen U1, V1, W1 an die Phasen L1, L2, L3 an, dreht sich der Motor, mit Sicht auf die Motorwelle betrachtet, im Uhrzeigersinn. Eine Drehrichtungsumkehr gegen den Uhrzeigersinn erhält man durch das Wechseln von zwei Phasen.

#### M4 - SENS DE ROTATION

Le fonctionnement des moteurs dans les deux sens de rotation est possible. Avec raccordement des bornes U1, V1, W1 aux phases de ligne L1, L2, L3 on obtient la rotation dans le sens des aiguilles d'une montre, en observant l'arbre côté accouplement. Invertir deux des phases pour obtenir la rotation dans le sens inverse des aiguilles d'une montre.

#### M5 - CUSCINETTI

I cuscinetti previsti sono del tipo radiale a sfere, precaricati assialmente, e dotati di carica di grasso per lubrificazione permanente.

La durata nominale a fatica  $L_{10h}$  in assenza di carichi esterni applicati all'albero e montaggio orizzontale è superiore a 40.000 ore. I tipi utilizzati sono indicati nella tabella seguente:

#### M5 - BEARINGS

Axially pre-loaded radial ball bearings, lubricated for life with the grease.

Nominal fatigue life  $L_{10h} \sim 40,000$  hours assuming no overhung load on the shaft, and mounting position horizontal.

The types of bearings in use are listed in the table below:

#### M5 - LAGER

Bei den verwendeten Lagern handelt es sich um axial vorgespannte Radialkugellager mit einer für die Dauerschmierung ausgelegten Fettfüllung. Der Nennwert der Ermüdungsdauer  $L_{10h}$  ohne auf die Welle einwirkenden Kräften und bei horizontaler Montage liegt bei über 40.000 Stunden:

#### M5 - ROULEMENTS

Les roulements prévus sont du type radial à billes, préchargés du point de vue axial et remplis de graisse pour une lubrification permanente.

La durée nominale à la fatigue  $L_{10h}$ , en l'absence de charges externes appliquées à l'arbre et avec un montage horizontal, est supérieure à 40.000 heures :

(05)

	DE	NDE	
	Tutti i motori / All motors Alle Motoren / Tous les moteurs		BN_FD; BN_FA
<b>BN 56</b>	6201 2Z C3	6201 2Z C3	—
<b>BN 63</b>	6201 2Z C3	6201 2Z C3	6201 2RS C3
<b>BN 71</b>	6202 2Z C3	6202 2Z C3	6202 2RS C3
<b>BN 80</b>	6204 2Z C3	6204 2Z C3	6204 2RS C3
<b>BN 90</b>	6205 2Z C3	6205 2Z C3	6205 2RS C3
<b>BN 100</b>	6206 2Z C3	6206 2Z C3	6206 2RS C3
<b>BN 112</b>	6306 2Z C3	6306 2Z C3	6306 2RS C3
<b>BN 132</b>	6308 2Z C3	6308 2Z C3	6308 2RS C3
<b>BN 160MR</b>	6309 2Z C3	6308 2Z C3	6308 2RS C3
<b>BN 160M/L</b>	6309 2Z C3	6309 2Z C3	6309 2RS C3
<b>BN 180M</b>	6310 2Z C3	6309 2Z C3	6309 2RS C3
<b>BN 180L</b>	6310 2Z C3	6310 2Z C3	6310 2RS C3
<b>BN 200L</b>	6312 2Z C3	6310 2Z C3	6310 2RS C3

DE = lato comando

NDE = lato opposto comando

DE = drive end

NDE = non drive end

DE = Wellenseite

NDE = Lüfterseite

DE = sortie arbre

NDE = côté ventilateur

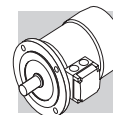

## M6 - OPERATIVITÀ STANDARD

### M6.1 - TENSIONE

I motori a singola polarità sono previsti, nell'esecuzione standard, per tensione nominale 230/400V  $\Delta/Y$  (o 400/690 V  $\Delta/Y$  per le grandezze da BN160 e BN 200) 50 Hz con tolleranza  $\pm 10\%$  (Eurotensione).

I motori sono idonei per funzionamento sulla rete di distribuzione europea con tensione in accordo alla pubblicazione IEC 60038.

In targa sono indicati oltre alla tensione nominale, i campi di funzionamento consentiti, p.e. 220-240V  $\Delta/380-415V Y$ , 50 Hz. In accordo alla Norma CEI EN 60034-1, i motori possono funzionare alle tensioni sopra indicate con tolleranza del  $\pm 5\%$  (Zona A).

Per funzionamento ai limiti della tolleranza la temperatura può superare di 10 K il limite previsto dalla classe di isolamento adottata.

## M6 - STANDARD OPERATION

### M6.1 - VOLTAGE

*Standard single-speed motors are designed to operate from a rated voltage 230/400V  $\Delta/Y$  (or 400/690V  $\Delta/Y$  for frame sizes BN 160 through BN 200) 50 Hz, with  $\pm 10\%$  tolerance (Euro-voltage).*

*Motors are suitable for operation with European power mains with voltage in accordance with publication IEC 60038.*

*Besides rated voltage, the name plate reports allowed operating ranges, e.g. 220-240V  $\Delta/380-415V Y$ , 50Hz. In accordance with standard CEI EN 60034-1, motors may operate at the above mentioned voltages with  $\pm 5\%$  tolerance (Zone A).*

*In operation at tolerance limits, temperature may exceed the temperature limit required by the adopted insulation class by 10 K.*

## M6 - STANDARDVERSORGUNG

### M6.1 - SPANNUNG

Die einpoligen Motoren sind in der Standardausführung für eine Nennspannung von 230/400V  $\Delta/Y$  (oder 400/690V  $\Delta/Y$  für die Baugrößen von BN 160 bis BN 200) 50 Hz, mit einer Toleranz  $\pm 10\%$  (Euro-Spannung) ausgelegt. Diese Motoren eignen sich für einen Betrieb im Europäischen Versorgungsnetz mit einer Spannung, die den in der Veröffentlichung IEC 60038 angegebenen Werten entspricht. Auf dem Typenschild werden über die Nennspannung hinaus, auch die zulässigen Toleranzbereiche angegeben, z.B. 220-240V  $\Delta/380-415V Y$ , 50 Hz. In Übereinstimmung mit der Norm CEI EN 60034-1 können die Motoren unter den o.g. Spannungswerten mit einer Toleranz von  $\pm 5\%$  (Bereich A) arbeiten. Bei einem Betrieb an den Toleranzgrenzen kann die Temperatur die vorgesehene Isolationsklasse um 10 K überschreiten.

## M6 - CONDITIONS OPERATIVES

### M6.1 - TENSION

*Les moteurs à simple polarité sont prévus, dans l'exécution standard, pour une tension nominale de 230/400V  $\Delta/Y$  (ou 400/690V  $\Delta/Y$  pour les tailles de BN 160 à BN 200) 50 Hz, avec une tolérance de  $\pm 10\%$  (Eurotension). Les moteurs sont adaptés pour fonctionner sur le réseau de distribution européen avec une tension correspondant aux indications de la norme CEI 60038. Sur la plaque signalétique sont indiquées, outre la tension nominale, les plages de fonctionnement autorisées, par ex. 220-240V  $\Delta/380-415V Y$ , 50 Hz. En accord avec la norme CEI EN 60034-1, les moteurs peuvent fonctionner aux tensions susmentionnées avec une tolérance de  $\pm 5\%$  (Zone A). Pour un fonctionnement aux limites de la tolérance, la température peut dépasser de 10 K la limite prévue pour la classe d'isolation adoptée.*

(06)

	$V_{mot} \pm 10\%$ 3~	Esecuzione Configuration Ausführung Execution
<b>BN 56 ... BN 132</b>	230/400 V $\Delta/Y$ 460 V Y	50 Hz 60 Hz Standard
<b>BN 160 ... BN 200</b>	400/690 V $\Delta/Y$ 460 V $\Delta$	50 Hz 60 Hz Standard
<b>BN 100 ... BN 132</b>	400/690 V $\Delta/Y$ 460 V $\Delta$	50 Hz 60 Hz A richiesta, senza sovrapprezzo At request, carries no extra charge Auf Anfrage, ohne Aufpreis Sur demande, sans majoration de prix

I motori a doppia polarità sono previsti per alimentazione standard 400V / 50 Hz; tolleranze applicabili secondo CEI EN 60034-1.

Nella tabella (07) sono indicati i collegamenti previsti in funzione della polarità:

*Switch-pole motors are designed to operate from 400V - 50 Hz standard power supply. Applicable tolerances are in accordance with standard CEI EN 60034-1. The table (07) reports the required connections depending on the number of poles:*

Die polumschaltbaren Motoren sind für eine Standardversorgung von 400V – 50 Hz ausgelegt; Toleranzen gelten gemäß CEI EN 60034-1. In der Tabelle (07) werden in Abhängigkeit von den jeweiligen Polzahlen die Wicklungsanschlüsse angegeben:

*Les moteurs à double polarité sont prévus pour une alimentation standard 400V – 50 Hz ; tolérances applicables selon la norme CEI EN 60034-1. Les branchements prévus en fonction de la polarité sont indiqués sur le tableau (07) :*

(07)

	Poli Number of poles Polzahl Nombre de poles	Collegamento avvolgimento Winding connection Wicklungsanschluß Connexion du bobinage
<b>BN 63 ... BN 200</b>	2,4,6,8	$\Delta/Y$
	2/4, 4/8	$\Delta/Y Y$ (Dahlander)
	2/6, 2/8, 2/12, 4/6	Y / Y (due avvolgimenti / Two windings / Zwei wicklungen / Deux bobinage)



## M6.2 - FREQUENZA

I motori della serie BN sono previsti per essere normalmente utilizzati su reti a 50 Hz o 60 Hz.

## M6.2 - FREQUENCY

The motors of the BN series may operate under 50 or 60 Hz supply.

## M6.2 - FREQUENZ

Die Motoren der Serie BN können mit 50 Hz oder 60 Hz betrieben werden.

## M6.2 - FREQUENCE

Les moteurs de la série BN peuvent être normalement utilisés sur des réseaux en 50 Hz ou 60 Hz.

## M6.3 - TEMPERATURA AMBIENTE

Le tabelle dati tecnici del catalogo riportano le caratteristiche funzionali a 50Hz, per le condizioni di installazione previste dalle Norme CEI EN 60034-1 (temperatura compresa tra -15 °C e +40 °C ed altitudine ≤ 1000 m s.l.m.).

I motori possono essere impiegati con temperature comprese tra 40 °C e 60 °C applicando i declassamenti di potenza indicati nella tabella (08):

## M6.3 - AMBIENT TEMPERATURE

Catalog rating charts report operating characteristics at 50 Hz, under installation conditions as specified by standards CEI EN 60034-1 (temperature between -15 °C and + 40 °C and altitude above sea level ≤ 1000 m).

Motors may be used at ambient temperatures between 40°C and 60°C as long as the derating factors listed in the table (08) are applied:

## M6.3 - UMGEBUNGSTEMPERATUR

Die im Katalog enthaltenen Tabellen geben die Betriebsdaten bei 50 Hz für die Einbaubedingungen gemäß den Normen CEI EN 60034-1 (Temperatur zwischen -15 °C und + 40 °C und Höhe ≤ 1000 m ü. M.) an. Die Motoren können auch bei Temperaturen zwischen 40°C und 60°C eingesetzt werden, in diesem Fall müssen jedoch die in der Tabelle (08) angegebenen Leistungsreduzierungen beachtet werden:

## M6.3 - TEMPERATURE AMBIANTE

Les tableaux des caractéristiques techniques du catalogue indiquent les caractéristiques de fonctionnement à 50 Hz, pour les conditions d'installation prévues par les normes CEI EN 60034-1 (température comprise entre -15 °C et + 40 °C à une altitude de ≤ 1000 m). Les moteurs peuvent être utilisés à des températures comprises entre 40°C et 60°C en appliquant les déclassements de puissance indiqués dans le tableau (08) :

(08)

Temperatura ambiente / Ambient temperature Umgebungstemperatur / Température ambiante [°C]	40°	45°	50°	55°	60°
Potenza ammissibile in % della potenza nominale Permitted power as a % of rated power Zulässige Leistung in % der Nennleistung Puissance admissible en % de la puissance nominale	100%	95%	90%	85%	80%

Quando è richiesto un declassamento del motore superiore al 15%, contattare il ns. Servizio Tecnico.

When the applicable derating factor for the motor exceeds 15%, please contact our Technical Service Dept.

Ist eine Rückstufung des Motors von mehr als 15% erforderlich, setzen sie sich bitte mit unserem Technischen Kundendienst in Verbindung.

En cas de nécessité d'un déclassement du moteur supérieur à 15%, contacter notre Service Technique.

## M7 - FUNZIONAMENTO A 60 Hz

I motori della serie BN possono essere normalmente utilizzati anche su reti a 60 Hz.

Ad esclusione dei motori autofrenanti in c.c., tipo BN\_FD, nella targa dei motori, oltre alle tensioni a 50 Hz, sono riportati i valori corrispondenti al funzionamento a 460 V - 60Hz, ed il relativo campo di tensione 440-480V.

## M7 - 60 Hz OPERATION

BN motors may also operate with 60 Hz power mains.

Except for DC brake motors type BN\_FD, motor name plate reports 50 Hz voltage ratings, as well as the values for operation at 460 V - 60Hz and the corresponding voltage range 440-480V.

## M7 - BETRIEB BEI A 60 Hz

Die Motoren der Serie BN können normalerweise auch in Stromnetzen mit 60 Hz Frequenz eingesetzt werden.

Mit Ausnahme der Bremsmotoren mit Gleichstromes vom Typ BN\_FD, werden auf dem Typenschild der Motoren über die Angabe der Spannungen bei 50 Hz auch die Werte angegeben, die einem Betrieb bei 460 V - 60Hz entsprechen. Darüber hinaus kann man diesem Schild den entsprechenden Spannungsbereich 440-480V entnehmen.

## M7 - FONCTIONNEMENT A 60 Hz

Les moteurs de la série BN peuvent aussi être normalement utilisés sur des réseaux à 60 Hz.

A l'exception des moteurs frein en c.c., type BN\_FD, sur la plaque signalétique des moteurs, outre la tension à 50 Hz, sont indiqués les valeurs correspondant au fonctionnement à 460 V - 60Hz ainsi que la plage de tension relative 440-480V.

In corrispondenza dell'alimentazione 460V-60 Hz la targa del motore riporta valori di potenza aumentata di circa il 20% (non applicabile ai motori autofrenanti con freno in c.c., tipo BN\_FD).

For 460V-60 Hz power supply, the power ratings reported in the motor name plate are about 20% higher (does not apply to DC brake motors type BN\_FD). Name plate rated power for op-

Bei einer Spannungsversorgung mit 460V-60 Hz werden auf dem Typenschild etwa 20% höhere Leistungswerte angegeben (gilt nicht für die Bremsmotoren mit Gleichstrombremse

En face de l'alimentation 460V-60 Hz la plaque signalétique du moteur indiquent les valeurs de puissance majorée d'environ 20% (non applicable aux moteurs frein avec frein en



La potenza nominale di targa, a 60 Hz, è quella riportata nella tabella (09) seguente:

*eration with 60 Hz power mains is as reported in the table below (09):*

vom Typ BN\_FD). Der nachstehenden Tabelle (09) können Sie die auf dem Typenschild angegebene Nennleistung bei 60 Hz entnehmen:

*c.c., type BN\_FD).*

*La puissance nominale indiquée sur la plaque, à 60 Hz, est celle figurant dans le tableau (09) suivant :*

(09)

	Pn [kW]			
	2p	4p	6p	8p
<b>56A</b>	—	0.07	—	—
<b>56B</b>	—	0.10	—	—
<b>63A</b>	0.21	0.14	0.10	—
<b>63B</b>	0.30	0.21	0.14	—
<b>63C</b>	0.45	0.30	—	—
<b>71A</b>	0.45	0.30	0.21	0.10
<b>71B</b>	0.65	0.45	0.30	0.14
<b>71C</b>	0.90	0.65	0.45	—
<b>80A</b>	0.90	0.65	0.45	0.21
<b>80B</b>	1.30	0.90	0.65	0.30
<b>80C</b>	1.80	1.3	0.90	—
<b>90S</b>	—	1.3	0.90	0.45
<b>90SA</b>	1.8	—	—	—
<b>90SB</b>	2.2	—	—	—
<b>90L</b>	2.5	—	1.3	0.65
<b>90LA</b>	—	1.8	—	—
<b>90LB</b>	—	2.2	—	—
<b>100L</b>	3.5	—	—	—
<b>100LA</b>	—	2.5	1.8	0.85
<b>100LB</b>	4.7	3.5	2.2	1.3
<b>112M</b>	4.7	4.7	2.5	1.8
<b>132S</b>	—	6.5	3.5	2.5
<b>132SA</b>	6.5	—	—	—
<b>132SB</b>	8.7	—	—	—
<b>132M</b>	11	—	—	3.5
<b>132MA</b>	—	8.7	4.6	—
<b>132MB</b>	—	11	6.5	—
<b>160MR</b>	12.5	12.5	—	—
<b>160MB</b>	17.5	—	—	—
<b>160M</b>	—	—	8.6	—
<b>160L</b>	21.5	17.5	12.6	—
<b>180M</b>	24.5	21.5	—	—
<b>180L</b>	—	25.3	17.5	—
<b>200L</b>	34	34	22	—



Per i motori a doppia polarità con frequenza di alimentazione 60Hz l'incremento di potenza previsto, rispetto a quanto riportato nelle tabelle dati tecnici a 50 Hz, è circa del 15%.

I motori ad una velocità con avvolgimento standard, se utilizzati su reti a 60 Hz e tensioni come riportato in tabella (10), presentano variazioni delle grandezze principali come nel seguito descritto:

*For switch-pole motors operating with 60 Hz input frequency, the power increase factor over 50 Hz ratings is in the order of 15%.*

*Key parameter variations for single-pole motors with standard winding operating with 60 Hz power mains at the voltage ratings reported in the table (10) are reported below (variations expressed as percentages):*

Für die polumschaltbaren Motoren mit einer Spannungsversorgung von 60 Hz beträgt die Leistungserhöhung im Vergleich zu den Angaben in der Tabelle der sich auf 50 Hz beziehenden technischen Daten ungefähr 15%.

Für die einpoligen Motoren mit Standardwicklung die in Versorgungsnetzen mit 60 Hz und mit Spannungen gemäß Tabelle (10) eingesetzt werden, gelten die folgenden Werte:

*Pour les moteurs à double polarité avec fréquence d'alimentation 60 Hz l'augmentation de puissance prévue, par rapport aux indications des tableaux des caractéristiques techniques à 50 Hz, est d'environ 15%.*

*Les moteurs à une vitesse avec bobinage standard, lorsqu'ils sont utilisés sur des réseaux à 60 Hz et des tensions comme indiqué dans le tableau (10), présentent des variations des valeurs principales en pourcentage comme indiqué ci-dessous :*

(10)

50 Hz	60 Hz			
V	V	Pn	Mn, Ma/Mn	n [min <sup>-1</sup> ]
230/400 Δ /Y	220 - 240 Δ 380 - 415 Y	1	0.83	1.2
400/690 V Δ /Y	380 - 415 Δ			
230/400 V Δ /Y	265 - 280 Δ 440 - 480 Y	1.15	1	1.2
400/690 V Δ /Y	440 - 480 Δ			

I freni, se presenti, dovranno sempre essere alimentati come riportato in targa.

*Brakes, if fitted, must always be supplied as specified on the name plate.*

Die Bremsen, falls vorhanden, müssen immer wie gezeichnet auf dem Typenschild versorgt werden.

*Si présents, les freins doivent toujours être alimentés indiquée sur la plaque signalétique.*

## PN

L'opzione consente di avere sulla targa del motore il valore di potenza normalizzata a 50 Hz, anche quando è specificata l'alimentazione a 60 Hz.

*With this option, motor name plate includes 50 Hz normalized power information even when motor is designated for operation with 60 Hz power mains.*

Diese Option ermöglicht es auf dem Typenschild des Motors den Wert der auf 50 Hz genormten Leistung angeben zu können, auch wenn eine Spannungsversorgung bei 60 Hz erfolgt.

*L'option permet d'avoir sur la plaque signalétique du moteur la valeur de puissance normalisée à 50 Hz, même lorsque l'alimentation à 60 Hz est spécifiée.*

Per alimentazioni a 60 Hz con le tensioni 230/460V e 575V l'opzione PN viene applicata di default.

*For 60 Hz supplies along with voltages 230/460V and 575V the PN option is applied by default.*

Die Option PN ist immer dabei mit 60 Hz und Spannungsversorgung 230/460V und 575V 60 Hz.

*Pour alimentations à 60 Hz avec tensions 230/460V et 575V l'option PN est appliqué de default.*





### M7.1 - MOTORI PER USA E CANADA

### M7.1 - MOTORS FOR USA AND CANADA

### M7.1 - MOTOREN FÜR DIE USA UND KANADA

### M7.1 - MOTEURS POUR ETATS-UNIS ET CANADA

## CUS

I motori da BN 56 a BN 200 sono disponibili in esecuzione NEMA Design C (per le caratteristiche elettriche), certificata in conformità alle norme CSA (Canadian Standard) C22.2 N°100 e UL (Underwriters Laboratory) UL 1004 con targhetta riportante entrambi i marchi sotto illustrati:

*BN motor's sizes 56 through 200, are available in NEMA Design C configuration (concerning electrical characteristics), certified to CSA (Canadian Standard) C22.2 No. 100 and UL (Underwriters Laboratory) UL 1004. By specifying the option CUS the name plate is marked with both symbols shown here below:*

Die Motoren BN 56 bis BN 200 sind in der Ausführung NEMA, Design C erhältlich (hinsichtlich der elektrischen Eigenschaften). Zertifiziert nach den Normen CSA (Canadian Standard) C22.2 Nr. 100 und UL (Underwriters Laboratory) UL 1004. Durch Spezifizieren der Option CUS wird das Typenschild mit den nachstehend aufgeführten Symbolen gekennzeichnet:

*Les moteurs BN 56..BN 200 sont disponibles en exécution NEMA Design C (pour les caractéristiques électriques), certifiée conforme aux normes CSA (Canadian Standard) C22.2 N°100 et UL (Underwriters Laboratory) UL 1004 avec une plaque signalétique indiquant chacun des symboles ci-dessous :*



(tensione ≤ 600V).

*(voltage ≤ 600V)*

Zeichen (Spannung ≤ 600V) versehen.

*(tension ≤ 600V).*

Le tensioni delle reti di distribuzione americane e le corrispondenti tensioni nominali da specificare per il motore sono indicate nella tabella seguente:

*US power mains voltages and the corresponding rated voltages to be specified for the motor are indicated in the following table:*

Die Spannungen der amerikanischen Verteilernetze und die entsprechenden Nennspannungen, die bei der Bestellung der Motore angegeben werden müssen, können der folgenden Tabelle entnommen werden:

*Les tensions des réseaux de distribution américains ainsi que les tensions nominales à spécifier pour le moteur sont indiquées dans le tableau suivant :*

(11)

Frequenza <i>Frequency</i> Frequenz <i>Fréquence</i>	Tensione di rete <i>Mains voltage</i> Netzspannung <i>Tension de réseau</i>	Tensione nominale motore <i>Motor rated voltage</i> Nennspannung des Motors <i>Tension nominale moteur</i>
60 Hz	208 V	<b>200 V</b>
	240 V	<b>230 V</b>
	480 V	<b>460 V</b>
	600 V	<b>575 V</b>

I motori dotati di collegamento YY/Y (es. 230/460-60; 220/440-60) presentano di serie una morsettiere a 9 terminali.

*Motors with YY/Y connection (e.g. 230/460-60; 220/440-60) feature, as standard, a 9-stud terminal board. For same executions, as well as for 575V-60Hz supply, the nominal rating is coincident with the correspondent 50Hz rating.*

Motoren mit YY/Y-Anschluss (z.B. 230/460-60; 220/440-60) sind standardmäßig mit 9 Pins auf dem Klemmbrett ausgeführt. Für gleiche Ausführungen, ebenso wie für 575V-60Hz, die Nennleistung ist gleich mit der entsprechenden 50 Hz-Leistung. Für Bremsmotoren mit Gleichstrombremse vom Typ BN\_FD erfolgt die Versorgung des Gleichrichters über den Motorklemmenkasten mit einer

*Les moteurs avec connexion YY/Y (ex. 230/460-60; 220/440-60) présentent, en standard, une plaque à borne avec 9 bornes. Pour les mêmes executions, et aussi pour l'alimentation 575V-60Hz, la puissance de plaque correspond à celle normalisé à 50Hz.*

Per le stesse esecuzioni, e inoltre per l'alimentazione 575V-60Hz, la potenza di targa corrisponde a quella normalizzata a 50Hz.

*For DC brake motors type BN\_FD, the rectifier is connected to a single-phase 230 VAC supply voltage in the motor terminal box.*

*Pour les moteurs frein avec frein en c.c. type BN\_FD, l'alimentation du redresseur provient de la boîte à bornes moteur avec une tension 230V c.a. monophasée.*



Per i motori autofrenanti l'alimentazione del freno è così predisposta:

**Brake power supply for brake motors is as follows:**

Spannung von 230V (einphasiger Wechselstrom). Bei Bremsmotoren stellt sich die **Versorgung der Bremse** wie folgt dar:

**Pour les moteurs frein l'alimentation du frein est la suivante :**

(12)	<b>BN_FD</b>	<b>BN_FA ; BN_BA</b>	Specificare: Power supply: Bitte angeben: Spécifier :
	Da morsettiere motore <i>Connected to terminal box</i> Vom Motorklemmenkasten <i>Depuis boîte à bornes moteur</i>	Alimentazione separata <i>Separate power supply</i> Fremdversorgung <i>Alimentation séparée</i> 230 V Δ - 60 Hz	<b>230SA</b>
	1~ 230 V a.c.	Alimentazione separata <i>Separate power supply</i> Fremdversorgung <i>Alimentation séparée</i> 460 V Y - 60 Hz	<b>460SA</b>

L'opzione CUS non è applicabile ai motori dotati di servoventilazione.

*The option CUS does not apply to servo-ventilated motors.*

Die CUS-Option ist für die Fremdlüftermotoren nicht anwendbar

*L'option CUS n'est pas applicable aux moteurs doués de ventilation forcée.*

**M7.2 - CHINA COMPULSORY CERTIFICATION**

**M7.2 - CHINA COMPULSORY CERTIFICATION**

**M7.2 - CHINA COMPULSORY CERTIFICATION**

**M7.2 - CHINA COMPULSORY CERTIFICATION**



I motori elettrici destinati ad essere commercializzati nella Repubblica Popolare Cinese rientrano nell'applicabilità del sistema di certificazione CCC (China Compulsory Certification). I motori BN con coppia nominale fino a 7Nm sono disponibili con certificazione CCC e targhetta speciale riportante il marchio sotto illustrato:

*Electric motors destined for sale in the People's Republic of China have to be certified under the CCC (China Compulsory Certification) system. BN motors of up to 7 Nm in rated torque are available with CCC certification and a special nameplate bearing the mark shown below:*

Die für den Vertrieb in der Volksrepublik China vorgesehenen Elektromotoren fallen unter den Geltungsbereich des Zertifizierungssystems CCC (China Compulsory Certification). Die Motoren der Serie BN mit Nennmoment bis 7 Nm sind mit CCC-Zertifizierung und Sondertypenschild mit der unten dargestellten Marke erhältlich:

*Les moteurs électriques destinés à être commercialisés dans la République Populaire de Chine rentrent dans le cadre du système de certification CCC (China Compulsory Certification). Les moteurs BN ayant un couple nominal pouvant atteindre 7 Nm sont disponibles avec une certification CCC et une plaque spéciale sur laquelle figure la marque illustrée ci-dessous :*



**M8 - ALIMENTAZIONE DA INVERTER**

**M8 - INVERTER CONTROL**

**M8 - FREQUENZUMRICHTER-BETRIEB**

**M8 - ALIMENTATION PAR VARIATEUR**

I motori elettrici della serie BN possono essere utilizzati con alimentazione da inverter PWM e tensione nominale all'ingresso del convertitore fino a 500 V. Il sistema isolante adottato sui motori di serie prevede l'isolamento di fase con separatori, l'utilizzo di filo smaltato in grado 2 e resine d'impregnazione in

*The BN type electric motors are suitable for PWM inverter control with rated voltage at transformer input up to 500 V. The insulating system adopted on standard motors uses phase insulation with separators, grade 2 enamelled wire and impregnation resins in class H (maximum voltage pulse 1600*

Die Elektromotoren der Serie BN können mit einem Frequenzumrichter und einer Nennspannung am Eingang des Umrichters bis zu 500 V versorgt werden. Die Motoren haben eine Phasentrennung über Wicklungstrenner, Emaildraht der Klasse 2 mit Imprägnierharzen der

*Les moteurs électriques de la série BN peuvent être utilisés avec alimentation par variateur PWM, et tension nominale en entrée du convertisseur jusqu'à 500V. Le système isolant adopté sur les moteurs de série prévoit l'isolation de phase avec séparateurs, l'utilisation de fil émaillé niveau 2 et résines d'impregnation*

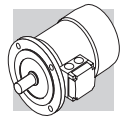

classe H (limite di tenuta all'impulso di tensione 1600V picco-picco e fronte di salita  $t_s > 0.1 \mu s$  ai morsetti motore).

Le caratteristiche tipiche coppia/velocità in servizio S1 per motore con frequenza base  $f_b = 50$  Hz sono riportate nella tabella seguente.

Per frequenze di funzionamento inferiori a circa 30 Hz, a causa della diminuzione della ventilazione, i motori standard autoventilati (IC 411) devono essere opportunamente declassati in coppia o, in alternativa, devono essere provvisti di ventilatore con alimentazione separata (vedi par. M12).

Per frequenze maggiori alla frequenza base, raggiunto il valore massimo di tensione di uscita dell'inverter, il motore lavora in un campo di funzionamento a potenza costante, con coppia all'albero che si riduce ca. con il rapporto  $(f/f_b)$ .

Poiché la coppia massima del motore decresce ca. con  $(f/f_b)^2$ , il margine di sovraccarico ammesso dovrà essere progressivamente ridotto.

*V peak-to-peak and rise edge  $t_s > 0.1 \mu s$  at motor terminals).*

*Typical torque/speed characteristics for S1 duty for motors operating with basic frequency  $f_b = 50$  Hz is are reported in the table below.*

*Operating at the frequencies below 30 Hz impair ventilation efficiency, standard motors with incorporated fan (IC 411) require either a corresponding torque reduction or, alternately, a fan with separate power supply. (See par M12)*

*For frequencies greater than basic frequency, once inverter maximum output voltage has been reached, the motor will be working in a steady power operation range, with shaft torque decreasing approximately with ratio  $(f/f_b)$ .*

*As motor maximum torque decreases approximately with  $(f/f_b)^2$ , the permitted overload reserve will have to be reduced gradually.*

Klasse H vor (Widerstandsgrenze gegen einen Spannungsimpuls von 1600 V und Anstiegsrampe  $t_s > 0.1 \mu s$  an den Motor клемmen).

Die typischen Merkmale Drehmoment/Drehzahl in der Betriebsart S1 für Motoren mit einer Eckfrequenz von  $f_b = 50$  Hz werden in der nachstehenden Tabelle angegeben. Bei Frequenzen von unter 30 Hz liegenden Betriebsfrequenzen müssen die eigenbelüfteten Standardmotoren (IC 411) aufgrund ihrer geringeren Kühlwirkung in ihrem Drehmoment zurückgestuft oder, alternativ, mit einem Fremdlüfter ausgestattet werden (siehe Par. M12).

Wenn der Motor oberhalb der Eckfrequenz betrieben wird, arbeitet er im Feldschwächebereich. In diesem Bereich konstanter Leistung fällt das Drehmoment des Motors ungefähr um das Verhältnis  $(f/f_b)$  ab. Da die maximale Motordrehzahl sich mit ungefähr  $(f/f_b)^2$  verringert, muss die zulässige Belastungsgrenze in progressiv reduziert werden.

*de classe H (limite de maintien à l'impulsion de tension 1600V pic-pic et front de montée  $t_s > 0.1 \mu s$  aux bornes moteur).*

*Les caractéristiques typiques couple/vitesse en service S1 pour moteur avec fréquence de base  $f_b = 50$  Hz sont indiquées dans le tableau suivant. Pour des fréquences de fonctionnement inférieures à environ 30 Hz, à cause de la diminution de la ventilation, les moteurs standards autoventilés (IC411) doivent être opportunément déclassés au niveau du couple ou, en alternative, doivent être équipés de ventilateur avec alimentation séparée (voir paragraphe M12).*

*Pour des fréquences supérieures à la fréquence de base, une fois la valeur maximale de tension de sortie du variateur atteinte, le moteur fonctionne dans une plage de fonctionnement à puissance constante, avec un couple à l'arbre qui se réduit approximativement dans le rapport  $(f/f_b)$ . Etant donné que le couple maximum du moteur diminue approximativement en relation avec  $(f/f_b)^2$ , la marge de surcharge admise devra être progressivement réduite.*

(13)

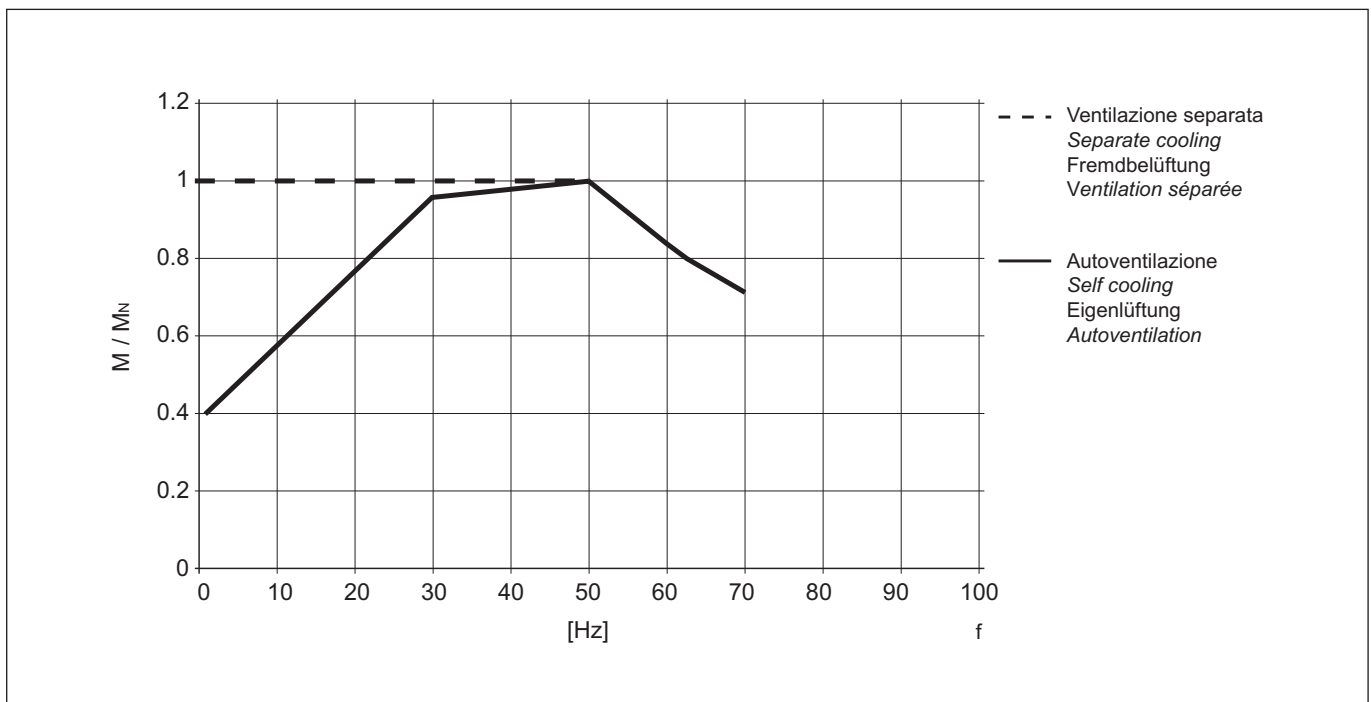



Per funzionamento oltre la frequenza nominale, la velocità limite meccanica dei motori è riportata nella tabella qui di seguito:

*The following table reports the mechanical speed limit for motors operating above rated frequency:*

Für Anwendungen, bei denen der Motor oberhalb der Eckfrequenz betrieben wird, finden sie die mechanische Drehzahlgrenzen in der folgenden Tabelle:

*En cas de fonctionnement au-delà de la fréquence nominale, la vitesse limite mécanique des moteurs est indiquée dans le tableau suivant :*

(14)

	n [min <sup>-1</sup> ]		
	2P	4P	6P/8P
<b>BN 56...BN 100</b>	5200	4000	3000
<b>BN 112</b>	5200	4000	3000
<b>BN 132...BN 160MR</b>	4500	4000	3000
<b>BN 160M...BN 180M</b>	4500	4000	3000
<b>BN 180L...BN 200L</b>	4500	3600	3000

A velocità superiori alla nominale i motori presentano maggiori vibrazioni meccaniche e rumorosità di ventilazione; è consigliabile, per queste applicazioni, un bilanciamento del rotore in grado B - opzione **RV** - ed eventualmente il ventilatore con alimentazione separata - opzioni **U1** o **U2**.

Sia il servomotorio, sia il freno elettromagnetico, devono sempre essere alimentati direttamente dalla rete.

*Motors operating above rated speed show an increased tendency for mechanical vibration and fan noise. When this is the case, rotor balancing in grade B - option **RV** - and possibly a fan with separate power supply - options **U1** or **U2** - should be specified.*

*Both servo-fan and electromagnetic brake require direct connection to mains power supply.*

Bei Drehzahlen oberhalb der Nenndrehzahlen weisen die Motoren stärkere mechanische Schwingungen und Lüftunggeräusche auf: In diesen Fällen wird das Auswuchten des Rotors im Grad B – Option **RV** – und eventuell die Installation eines Fremdlüfters – Option **U1** oder **U2** – empfohlen. Sowohl der Fremdlüfter als auch die elektromagnetische Bremse müssen bei Frequenzrichterbetrieb auf Grund der abfallenden Versorgungsspannung immer direkt über das Stromnetz versorgt werden.

*A des vitesses supérieures à la vitesse nominale, les moteurs présentent plus de vibrations mécaniques et de bruit de ventilation ; pour ces applications, il est conseillé d'effectuer un équilibrage du rotor en niveau B - option **RV** - et de monter éventuellement un ventilateur avec alimentation séparée – options **U1** ou **U2**.*

*Le servomotorio ainsi que le frein électromagnétique doivent toujours être alimentés directement par le réseau.*

#### M9 - TIPO DI SERVIZIO

Se non indicato diversamente, la potenza dei motori riportata a catalogo si riferisce al servizio continuo S1.

Per i motori utilizzati in condizioni diverse da S1 sarà necessario identificare il tipo di servizio previsto con riferimento alle Norme CEI EN 60034-1.

In particolare per servizi S2 ed S3 è possibile ottenere una maggiorazione della potenza rispetto a quella prevista per il servizio continuo secondo quanto indicato nella tabella che segue, valida per i motori a singola polarità. Per le maggiorazioni applicabili a motori a doppia polarità consultare preferibilmente il Servizio Tecnico Bonfiglioli.

#### M9 - TYPE OF DUTY

*Unless otherwise specified, catalogue motor power refers to continuous duty S1.*

*Any operating conditions other than S1 duty must be identified in accordance with duty cycle definitions laid down in standards CEI EN 60034-1.*

*For duty cycles S2 and S3, the power increase co-efficient reported in the following table may be used. Please note that the table provided below applies to single-speed motors.*

*Please contact Bonfiglioli Engineering for the power increase coefficients applicable to switch-pole motors.*

#### M9 - BETRIEBSARTEN

Sofern nicht anderweitig angegeben, beziehen sich die im Katalog angegebene Motorleistungen auf den Dauerbetrieb S1. Bei Motoren, die unter Bedingungen eingesetzt werden, die nicht mit S1 übereinstimmen, muss die entsprechende Betriebsart unter Bezugnahme auf die Normen CEI EN 60034-1 festgelegt werden. Insbesondere kann man, für die Betriebsarten S2 und S3, durch Anwendung der in der nachstehenden Tabelle angeführten Koeffizienten der für den Dauerbetrieb vorgesehenen Leistung gegenüber eine Leistungssteigerung erzielen. Diese Tabelle gilt für einpolige Motoren. Für die polumschaltbaren Motoren sollte man sich im Hinblick auf den Leistungssteigerung, mit unserem Technischen Kundendienst in Verbindung setzen.

#### M9 - TYPE DE SERVICE

*Sauf indication contraire, la puissance des moteurs indiquée dans le catalogue se réfère au service continu type S1. Pour les moteurs utilisés dans des conditions différentes de S1, il est nécessaire d'identifier le type de service en se référant aux Normes CEI EN 60034-1. Plus particulièrement, pour les types de service S2 et S3 il est possible d'obtenir une majoration de la puissance par rapport à celle prévue pour le service continu, en appliquant les coefficients indiqués dans le tableau suivant, valable pour les moteurs à simple polarité. En ce qui concerne les majorations applicables aux moteurs à double polarité, il est préférable de contacter le Service Technique Bonfiglioli.*

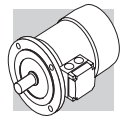

**S2**

Funzionamento a carico costante per un periodo di tempo limitato, inferiore a quello richiesto per raggiungere l'equilibrio termico, seguito da un periodo di riposo di durata sufficiente a ristabilire nel motore la temperatura ambiente.

*Operation under steady loading for a limited period of time (less than the time taken to achieve thermal balance), followed by a period of time at rest long enough for engine to cool down to ambient temperature.*

Betrieb mit konstanter Last für eine begrenzte Dauer, die unter der Zeit liegt, die für das Erreichen des thermischen Gleichgewichts erforderlich ist, gefolgt von einer Aussetzzeit mit einer Dauer, die für das erneute Erreichen der Umgebungstemperatur im Motor erforderlich ist.

*Fonctionnement à charge constante pendant une période de temps limitée, inférieure à celle nécessaire pour atteindre l'équilibre thermique, suivie par une période de repos de durée suffisante pour rétablir la température ambiante dans le moteur.*

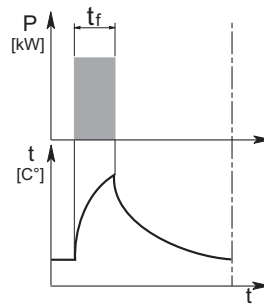

**S3**

Sequenza di cicli di funzionamento identici, ciascuno comprendente un periodo di funzionamento a carico costante ed un periodo di riposo. In questo tipo di servizio la corrente d'avviamento non influenza la sovratemperatura in modo significativo.

*A sequence of identical operation cycles, each including operation under steady loading followed by some time at rest. In this type of duty, starting current has no significant effect on overtemperature.*

Betriebsweise mit identischen Betriebszyklen, von denen jeder Zyklus eine Betriebsdauer mit konstanter Last und eine Aussetzzeit einschließt. Bei dieser Betriebsart beeinflusst der Anlaufstrom die Übertemperatur in keinerlei ausschlaggebender Weise.

*Séquence de cycles de fonctionnement identiques, comprenant chacun une période de fonctionnement à charge constante et une période de repos. Dans ce type de service, le courant de démarrage n'influence pas l'excès de température de façon significative.*

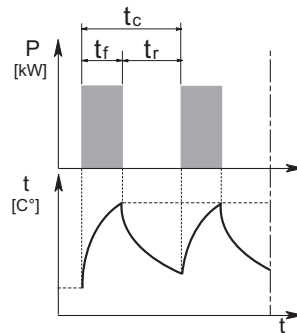

(15)	Tipo di Servizio Type of duty Betriebsart Type de service	Potenza ammissibile in p.u. della potenza in S1 Permitted power in p.u. of S1 power Zulässige Leistung in % der Leistung bei S1 Puissance admissible en p.u. de la puissance en S1
	Durata / Duration / Dauer / Durée	
<b>S2</b>	10 min	1.35
	30 min	1.15
	60 min	1.05
	Rapporto di intermittenza Intermittence / Schaltverhältnis Rapport d'intermittence (I)	
<b>S3</b>	25 %	1.25
	40 %	1.15
	60 %	1.10
<b>S4 ... S9</b>	Interpellarci / Contact us / Setzen Sie sich mit uns in Verbindung / Nous contacter	



$$I = \frac{t_f}{t_f + t_r} \cdot 100$$

$t_f$  = tempo di funzionamento sotto carico  
 $t_r$  = tempo di riposo

$t_f$  = work time under constant load  
 $t_r$  = rest time

$t_f$  = Betriebszeit mit konstanter Last  
 $t_r$  = Aussetzzeit

$t_f$  = temps de fonctionnement à charge constante  
 $t_r$  = temps de repos

La durata del ciclo dovrà essere  $\leq 10$  min. Per durate superiori interpellarci.

Cycle duration must be up to 10 min. Please contact us when cycle duration exceeds this limit.

Die Zyklusdauer muss  $\leq 10$  min. betragen. Falls der Zyklus länger sein sollte, setzen Sie sich bitte mit unserem Kundendienst in Verbindung.

La durée du cycle devra être  $\leq 10$  min. Pour des durées supérieures, nous contacter.

### M10 - MORSETTIERA MOTORE

La morsettiera principale è a 6 morsetti per collegamento con capicorda (esecuzione a 9 morsetti per tensioni americane "dual voltage" - vedi par. M7.1). All'interno della scatola coprimorsetti è previsto il morsetto di terra per il collegamento del conduttore di protezione.

Le dimensioni dei terminali sono riportati nella tabella (16). Per l'alimentazione del freno vedi par. M25 (freno FD), M26 + M27 (freno FA e BA).

Nei motori in forma costruttiva IM B3 la scatola coprimorsetti è posta in alto (posizione opposta ai piedi).

Eseguire i collegamenti elettrici secondo gli schemi riportati all'interno della scatola coprimorsettiera o nei manuali d'uso.

### M10 - TERMINAL BOX

The main terminal box has 6 terminals for connection to lead-in wires (9-terminal version is supplied for "dual voltage" US voltage ratings - see M7.1)

The ground terminal for earth lead connection is housed in the terminal box.

Terminal sizes are listed in the table (16).

For brake power supply, please read par. M25 (brake FD), M26 + M27 (brake FA and BA).

In motor design IM B3, the terminal box is top mounted (side opposite to feet).

Please refer to the wiring diagrams reported inside the terminal box, or in the operating instructions, for correct wiring.

### M10 - MOTORKLEMMENKASTEN

Der Klemmenkasten hat ein Klemmbrett mit 6 Klemmen für einen Anschluss über Kabelschuhe (für die amerikanischen Spannungswerte "dual voltage" sind 9 Klemmen vorgesehen – siehe M7.1. Im Inneren des Klemmenkastens ist ein Erdungsanschluß für den Anschluss des Schutzleiters vorgesehen. Die Abmessungen der Anschlüsse werden in der Tabelle (16) angegeben. Für Informationen über die Bremsversorgung verweisen wir an dieser Stelle auf den Par. M25 (Bremsstyp FD), M26 + M27 (Bremsstyp FA und BA). Bei Motoren in der Bauform IM B3 ist der Klemmenkasten oben angeordnet (den Füßen entgegengesetzt).

Die elektrischen Anschlüsse müssen entsprechend den Schaltplänen, die sich im Inneren des Klemmenkästen befinden oder in den Betriebsanleitungen zu finden sind, vorgenommen werden.

### M10 - BORNIER MOTEUR

Le bornier principal est de type à 6 bornes pour raccordement avec cosses (exécution à 9 bornes pour les tensions américaines "dual voltage" – voir M7.1). A l'intérieur du couvercle du bornier se trouve la borne de terre pour le raccordement du conducteur de protection.

Les dimensions des bornes sont indiquées dans le tableau (16). Pour l'alimentation du frein, voir par. M25 (frein FD), M26 + M27 (frein FA et BA). Sur les moteurs de forme de construction IM B3 la boîte à bornes est située en haut (à l'opposé des pieds).

Effectuer les branchements électriques selon les schémas indiqués à l'intérieur du couvercle de la boîte à bornes ou dans les manuels d'instructions.

(16)

	N° terminali No. of terminals Klemmen N° bornes	Filettatura terminali Terminal threads Gewinde Filetage bornes	Sezione max. del conduttore mm <sup>2</sup> Wire max cross section area sq mm <sup>2</sup> Max. leiter-querschnitt mm <sup>2</sup> Section max du conducteur mm <sup>2</sup>
<b>BN 56 ... BN 90</b>	6	M4	2.5
<b>BN 100 ... BN 160MR</b>	6	M5	6
<b>BN 160M ... BN 180M</b>	6	M6	16
<b>BN 180L ... BN 200L</b>	6	M8	25



### M10.1 - INGRESSO CAVI

Nell'esecuzione standard l'ingresso dei cavi di alimentazione è previsto per pressacavo metrici in accordo alla Norma CEI EN 50262. Dimensioni e disposizioni come indicato nelle tabelle che seguono.

### M10.1 - CABLE GLAND HOLES

Standard cable gland holes accommodate metric-size cable glands in accordance with standard CEI EN 50262. Dimensions and locations are as shown in the following tables.

### M10.1 - KABELDURCHFÜHRUNG

In der Standardversion ist die Ein- bzw. Durchführung der Kabel in Übereinstimmung mit der Norm CEI EN 50262 über metrische Kabelführungen vorgesehen. Maße und Anordnung werden in den folgenden Tabellen angegeben.

### M10.1 - ENTREE CABLES

Dans l'exécution standard, l'entrée des câbles d'alimentation est prévue pour des serre-câbles métriques, en accord avec la Norme CEI EN 50262. Dimensions et dispositions comme indiqué dans les tab. suivantes.

(17)

	N° ingresso cavi e dimensione No. & size of cable gland holes Kabeleingänge und masse Nb entrees câbles et dimensions		Ø Max. cavo [mm] Wire max Ø [mm] Max. Ø kabel [mm] Ø Max câble [mm]
<b>BN 56 ... BN 63</b>	2 x M 20 x 1.5	1 foro per lato 1 Hole on each side	13
<b>BN 71 ... BN 90</b>	2 x M 25 x 1.5	1 Bohrung pro Seite 1 Orifice par côté	17
<b>BN 100</b>	2 x M 32 x 1.5 2 x M 25 x 1.5	2 fori per lato 2 Holes on each side	21 17
<b>BN 112</b>	2 x M 32 x 1.5 2 x M 25 x 1.5	2 Bohrungen pro Seite 2 Orifices par côté	17
<b>BN 132 ... BN 160MR</b>	4 x M 32 x 1.5		21
<b>BN 160M ... BN 200L</b>	2 x M 40 x 1.5	Orientabili 4 x 90° Pivoting, 4 x 90° Orientierbar 4 x 90° Orientables 4 x 90°	28

### M11 - FORME COSTRUTTIVE

I motori sono previsti nelle forme costruttive IM B3, IM B5, IM B14 e derivate in accordo alla Norma CEI EN 60034-7, come indicato nella tabella seguente.

### M11 - DESIGN VERSIONS

Motors are available in the design versions IM B3, IM B5, IM B14 and derived versions in accordance with standard CEI EN 60034-7, as outlined in the table below.

### M11 - BAUFORMEN

Die Motoren sind in den Bauformen IM B3, IM B5, IM B14 und abgeleitete Versionen erhältlich und wurden in Übereinstimmung mit der Norm CEI EN 60034-7, entsprechend den Angaben in der nachstehenden Tabelle, realisiert.

### M11 - FORMES DE CONSTRUCTION

Les moteurs sont disponibles dans les formes de construction IM B3, IM B5, IM B14 et dérivées, en accord avec la Norme CEI EN 60034-7, comme indiqué dans le tableau suivant.

(18)

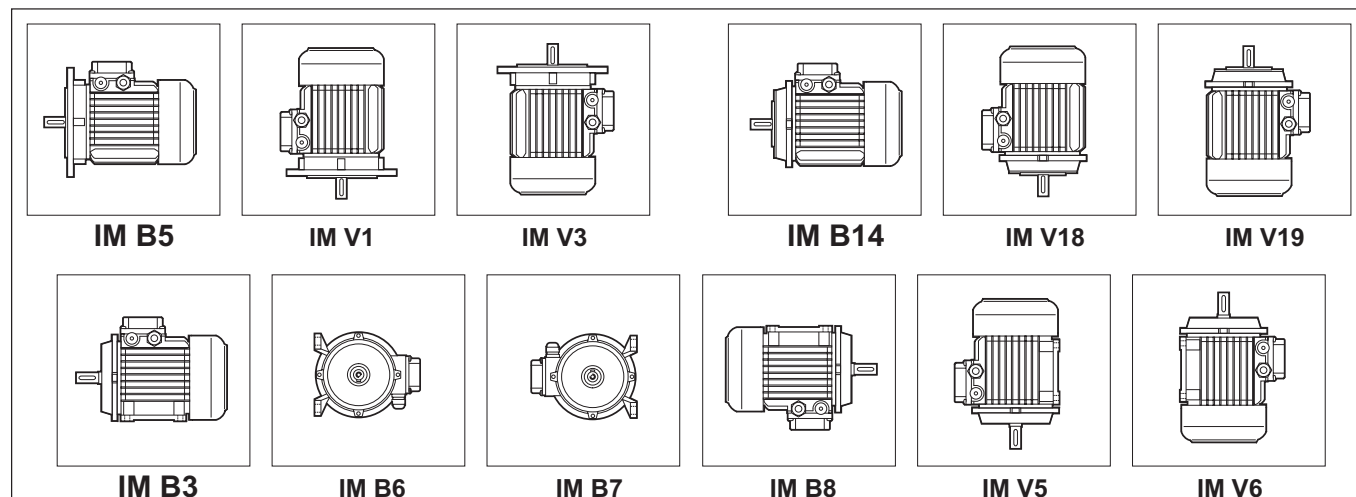



I motori, targati esclusivamente nella forma costruttiva base, possono essere installati anche nelle forme costruttive derivate, come illustrato nella tabella seguente:

*Motors in the derived design versions may also be installed as outlined in the table below. however, note that motor name plate will report the corresponding basic design version:*

Die Motoren werden auf dem Typenschild in der Einbaulage B3 angegeben, sie können aber auch in den anderen, in der nachfolgenden Tabelle angegebenen Bauformen montiert werden:

*Les moteurs, marqués exclusivement dans la forme de construction de base, peuvent aussi être installés dans les formes de construction dérivées, comme indiqué dans le tableau suivant :*

(19)

Forma costruttiva base Basic design version Gundbauform Forme de construction de base	Forma costruttiva derivata / Derived design version Andere Einbaulagen / Forme de construction dérivée				
<b>IM B3</b>	IM B6	IM B7	IM B8	IM V5	IM V6
<b>IM B5</b>	IM V1	IM V3			
<b>IM B14</b>	IM V18	IM V19			

Nelle installazioni con l'albero rivolto verso il basso è consigliabile specificare l'opzione **RC** - tettuccio parapioggia, vedi par. M23 in particolar modo nel caso di motore autofrenante.

*If motor is to be installed with the shaft pointing downwards, the rain canopy option RC – see par. M23 is recommended, especially where a brake motor is used.*

Bei Anwendungen mit senkrecht unten zeigender Welle, wird empfohlen, den Motor mit der Option **RC** – Schutzdach, siehe M23 zu bestellen, insbesondere dann, wenn es sich um einen Bremsmotor handelt. Die Motoren mit Flansch können mit reduzierten Wellen- und Flanschmaßen geliefert werden, die den Bauformen B5R oder B14R entsprechen und folgende Maße aufweisen:

*En ce qui concerne les installations avec arbre dirigé vers le bas, il est conseillé de spécifier l'option RC – capot antipluie, voir par. M23 plus particulièrement en cas de moteur frein. Les moteurs avec bride peuvent être fournis avec des dimensions d'accouplement réduites, correspondant aux formes de construction B5R ou B14R, avec les dimensions détaillées dans le tableau suivant :*

I motori in forma flangiata possono essere forniti con dimensioni di accoppiamento ridotte, corrispondenti alle forme costruttive B5R o B14R, con dimensioni dettagliate nella tabella seguente:

*Flange output motors are also available with reduced coupling dimensions corresponding to design versions B5R or B14R. Dimensions are indicated in the table below:*

(20)

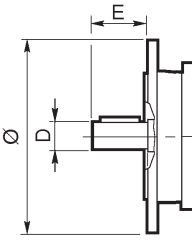
						
	<b>BN 71</b>	<b>BN 80</b>	<b>BN 90</b>	<b>BN 100</b>	<b>BN 112</b>	<b>BN 132</b>
	DxE - Ø					
<b>B5R</b> <sup>(1)</sup>	11x23 - 140	14x30 - 160	19x40 - 200	24x50 - 200	24x50 - 200	28x60 - 250
<b>B14R</b> <sup>(2)</sup>	11x23 - 90	14x30 - 105	19x40 - 120	24x50 - 140	—	—

<sup>(1)</sup> Flangia con fori passanti  
<sup>(2)</sup> Flangia con fori filettati

<sup>(1)</sup> Flange with through holes  
<sup>(2)</sup> Flange with tapped holes

<sup>(1)</sup> Flanschen mit durchgehenden Bohrungen  
<sup>(2)</sup> Flansch mit Gewindebohrungen

<sup>(1)</sup> Bride avec orifices passants  
<sup>(2)</sup> Bride avec orifices filetés





## M12 - VENTILAZIONE

I motori sono raffreddati mediante ventilazione esterna (IC 411 secondo CEI EN 60034-6) e sono provvisti di ventola radiale in plastica, funzionante in entrambi i versi di rotazione.

L'installazione dovrà assicurare una distanza minima della calotta copriventola dalla parete più vicina, in modo da non creare impedimento alla circolazione dell'aria, oltre che permettere l'esecuzione della manutenzione ordinaria del motore e, se presente, del freno.

Su richiesta, a partire dalla grandezza BN 71, i motori possono essere forniti con ventilazione forzata ad alimentazione indipendente. Il raffreddamento è realizzato per mezzo di un ventilatore assiale con alimentazione indipendente, montato sulla calotta copriventola (metodo di raffreddamento IC 416).

Questa esecuzione è utilizzata in caso di alimentazione del motore tramite inverter allo scopo di estendere il campo di funzionamento a coppia costante anche a bassa velocità, o quando per lo stesso sono richieste elevate frequenze di avviamento.

Da questa opzione sono esclusi i motori autofrenanti tipo BN\_BA e motori con doppia sporgenza d'albero (opzione PS).

## M12 - VENTILATION

*Motors are cooled by external ventilation systems (IC 411 in accordance with CEI EN 60034-6) and are equipped with a plastic radial fan running in both directions of rotation.*

*Installation must take into account a minimum distance of the fan cover from the nearest wall so as to ensure unobstructed air circulation. This also facilitates routine maintenance operations for motor and brake (if fitted).*

*At request, motor frame sizes BN 71 and larger may be equipped with forced ventilation with independent power supply. Motor is cooled by an axial ventilator mounted on the fan cover using an independent power supply (cooling method IC 416).*

*This design is adopted on inverter-controlled motors in order to extend torque-control operating range to include low speeds, or when the motor is to perform a large number of starts per hour.*

*This option is not compatible with brake motors type BN\_BA and motors with double-extended shaft (option PS).*

## M12 - KÜHLUNG

Die Motoren werden mittels Eigenbelüftung gekühlt (IC 411 gemäß CEI EN 60034-6) und sind mit einem Radiallüfterrad aus Kunststoff ausgestattet, das in beide Richtungen drehen kann. Bei der Montage des Motors muss darauf geachtet werden, das zwischen Lüfterhaube und dem nächsten Bauteil eine Mindestabstand einzuhalten, damit die Luftzirkulation nicht beeinträchtigt werden kann. Dieser Abstand ist ebenso für die regelmäßige Instandhaltung des Motors und, falls vorhanden, der Bremse erforderlich.

Ab der Baugröße BN 71 können die Motoren auf Anfrage mit einem unabhängig gespeisten Fremdlüfter geliefert werden. Die Kühlung erfolgt hier durch einen Axialventilator, der an Stelle der Standardlüfterhaube (Kühlmethode IC 416) montiert wird.

Diese Ausführung sollte eingesetzt werden, falls der Motor über einen Frequenzumrichter betrieben wird, so dass der Motor bei konstantem Drehmoment auch bei niedrige Drehzahlen oder bei hohen Anlaufrequenzen eingesetzt werden kann.

Von dieser Option ausgeschlossen sind die Bremsmotoren BN\_BA und Motoren mit zweitem Wellenende (Option PS).

## M12 - VENTILATION

*Les moteurs sont refroidis par ventilation externe (IC 411 selon CEI EN 60034-6) et sont équipés de ventilateur radial en plastique fonctionnant dans les deux sens de rotation.*

*L'installation doit garantir une distance minimum du capot cache-ventilateur par rapport au mur le plus proche de façon à ne pas créer d'empêchement à la circulation de l'air ainsi que pour permettre les interventions d'entretien ordinaire du moteur et, si présent, du frein. Sur demande, à partir de la taille BN 71, les moteurs peuvent être fournis avec ventilation forcée à alimentation indépendante. Le refroidissement est réalisé au moyen d'un ventilateur axial avec alimentation indépendante monté sur le capot cache-ventilateur (méthode de refroidissement IC 416).*

*Cette exécution est utilisée en cas d'alimentation du moteur par variateur dans le but d'étendre aussi la plage de fonctionnement à couple constant aux faibles vitesses ou lorsque des fréquences de démarrage élevées sont nécessaires à celui-ci.*

*Les moteurs frein type BN\_BA et les moteurs avec arbre sortant des deux côtés (option PS) sont exclus de cette option.*

**Tabella dati di alimentazione elettrica** *Power supply chart*

**Tabelle – Daten der Stromversorgung**

**Tableau caractéristiques de l'alimentation électrique**

(21)

BN		U1	V a.c. ± 10%	Hz	P [W]	I [A]
BN 71			1 ~ 230	50 / 60	22	0.12
BN 80					22	0.12
BN 90					40	0.30
BN 100					50	0.25
BN 112			3 ~ 230Δ / 400Y	50	50	0.26 / 0.15
BN 132 ... BN 160MR					110	0.38 / 0.22
BN 160M ... BN 180M					180	1.25 / 0.72
BN 180L ... BN 200L					250	1.51 / 0.87



(22)

BN  <b>U2</b>	V a.c. ± 10%	Hz	P [W]	I [A]
<b>BN 71</b>	1 ~ 230	50 / 60	22	0.12
<b>BN 80</b>			22	0.12
<b>BN 90</b>			40	0.30
<b>BN 100</b>	3 ~ 230Δ / 400Y		40	0.12 / 0.09
<b>BN 112</b>			50	0.26 / 0.15
<b>BN 132 ... BN 160MR</b>			110	0.38 / 0.22

Per la variante sono disponibili due esecuzioni alternative, denominate **U1** e **U2**, aventi lo stesso ingombro in senso longitudinale. Per entrambe le esecuzioni, la maggiore lunghezza della calotta copriventola ( $\Delta L$ ) è riportata nella tabella che segue. Dimensioni complessive ricavabili dalle tavole dimensionali dei motori.

*Variant is available in two alternative executions named **U1** and **U2**, featuring the same overall length. The largest length of fan cover ( $\Delta L$ ) for each configuration is reported in the following table. For overall dimensions, please see the dimension tables of motors.*

Für diese Optionsind als Alternative zwei Ausführungen verfügbar: **U1** und **U2** mit dem gleichen Längsmaßen. Für beide Ausführungen wird die Verlängerung der Lüfterhaube ( $\Delta L$ ) in der nachstehenden Tabelle wiedergegeben. Die Gesamtmaße der Motoren können den Tabellen mit den Motormaßen entnommen werden.

*Pour la variante sont disponibles deux exécutions alternatives, dénommées **U1** et **U2**, ayant le même encombrement dans le sens longitudinal. Pour les deux exécutions, la majoration de la longueur du capot cache-ventilateur ( $\Delta L$ ) est indiquée dans le tableau suivant. Dimensions totales à calculer d'après les planches de dimensions des moteurs.*

**Lunghezza aggiuntiva per motori con ventilazione indipendente**

**Extra length for motors with independent cooling**

**Zusätzliche Länge für Motoren mit unabhängiger Luftkühlung**

**Majoration longueur pour moteurs avec ventilation forcée à alimentation indépendante**

(23)

	$\Delta L_1$ [mm]	$\Delta L_2$ [mm]
<b>BN 71</b>	93	32
<b>BN 80</b>	127	55
<b>BN 90</b>	131	48
<b>BN 100</b>	119	28
<b>BN 112</b>	130	31
<b>BN 132 ... BN 160MR</b>	161	51
<b>BN 160M ... BN 180M</b>	184	184
<b>BN 180L ... BN 200L</b>	184	184

$\Delta L_1$  = variazione dimensionale rispetto alla lunghezza LB del motore standard corrispondente.

$\Delta L_1$  = dimension variation compared to length LB of the corresponding standard motor.

$\Delta L_1$  = Maßänderung gegenüber Maß LB des entsprechenden Standardmotors.

$\Delta L_1$  = variation de dimension par rapport à la cote LB du moteur standard correspondant.

$\Delta L_2$  = variazione dimensionale rispetto alla lunghezza LB del motore autofrenante corrispondente.

$\Delta L_2$  = dimension variation compared to length LB of the corresponding brake motor.

$\Delta L_2$  = Maßänderung gegenüber Maß LB des entsprechenden Bremsmotors.

$\Delta L_2$  = variation de dimension par rapport à la cote LB du moteur frein correspondant.

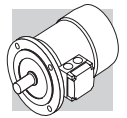

## U1

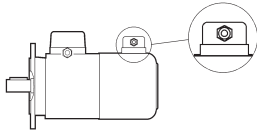

Terminali di alimentazione del ventilatore in scatola morsetti separata. Nei motori autofrenanti grandezza BN 71...BN 160MR, con variante **U1**, la leva di sblocco non è collocabile nella posizione AA (vedi par. M24.1).

L'opzione non è disponibile per i motori conformi alle norme CSA e UL (opzione CUS).

*Terminals of the independent fan motor are housed in a separate terminal box. The hand release cannot be located in the AA position for brake motors size BN71...BN160MR that feature the U1 type forced cooling, as described at section M24.1.*

*The option is not applicable to motors compliant with the CSA and UL norms (option CUS).*

Versorgungsanschlüsse des Ventilators im Zusatzklemmenkasten. Bei den Bremsmotoren in der Baugröße BN 71...BN 160MR, mit Variante **U1** kann der Bremslüfthebel nicht in der Position AA (siehe Par. M24.1) angeordnet werden.

Die Option ist nicht anwendbar für die Motoren entsprechend den Normen CSA und UL (Option CUS).

*Bornes d'alimentation du ventilateur dans une boîte à bornes séparée. Pour les moteurs frein taille BN 71...BN 160MR, avec variante **U1**, le levier de déblocage ne peut être installé en position AA (voir par. M24.1).*

*L'option n'est pas disponible pour les moteurs conformes aux normes CSA et UL (option CUS)*

## U2

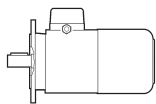

Terminali di alimentazione del ventilatore nella scatola morsetti principale del motore.

L'opzione U2 non è applicabile ai motori BN160M...BN200L e ai motori con l'opzione CUS (conformi alle norme CSA e UL).

*Terminals of the fan motor are located in the main terminal box.*

*The U2 option is not applicable to motors BN160M... BN200L and to motors with option CUS (compliant to norms CSA and UL).*

Versorgungsanschlüsse des Ventilators im Hauptklemmenkasten des Motors.

Die Option U2 ist nicht anwendbar bei den Motoren BN160M...BN200L und bei den Motoren mit der CUS-Option (entsprechend den Normen CSA und UL).

*Bornes d'alimentation du ventilateur dans la boîte à bornes principale du moteur.*

*L'option U2 n'est pas applicable aux moteurs BN160M... BN200L et aux moteurs avec l'option CUS (conforme aux normes CSA et UL).*



M13 - DESIGNAZIONE  
MOTORE

M13 - MOTOR  
DESIGNATION

M13 - MOTORBEZEICHNUNG

M13 - DESIGNATION  
MOTEUR

MOTORE / MOTOR  
MOTOR / MOTEUR

FRENO / BRAKE  
BREMSE / FREIN

**BN 63B 4 230/400-50 IP55 CLF B5 FD 3.5 R NB 220SA ...**

OPZIONI  
OPTIONS  
OPTIONEN  
OPTIONS

307

ALIMENTAZIONE FRENO  
BRAKE SUPPLY  
BREMSVERSORGUNG  
ALIMENTATION FREIN

320

TIPO RADDRIZZATORE AC/DC  
RECTIFIER TYPE  
GLEICHRICHTERTYP  
TYPE ALIMENTATEUR

325

LEVA DI SBLOCCO FRENO  
BRAKE HAND RELEASE  
BREMSENTHANDLÜFTUNG  
LEVIER DE DEBLOCAGE FREIN

318

COPPIA FRENANTE / BRAKE TORQUE  
BREMSMOMENT / COUPLE FREIN

327

331

335

TIPO FRENO / BRAKE TYPE / BRESENTYP / TYPE DE FREIN

323

329

333

FORMA COSTRUTTIVA / MOTOR EXECUTION  
BAUFORM / FORME DE CONSTRUCTION

301

CLASSE ISOLAMENTO / INSULATION CLASS  
ISOLIERUNGSKLASSE / CLASSE ISOLATION

310

GRADO DI PROTEZIONE / DEGREE OF PROTECTION  
SCHUTZART / DEGRE DE PROTECTION

308

TENSIONE-FREQUENZA / VOLTAGE-FREQUENCY  
SPANNUNG-FREQUENZ / TENSION-FREQUENCE

291

NUMERO DI POLI / NUMBER OF POLES / POLZAHL / N.bre POLES  
2, 4, 6, 8, 2/4, 2/6, 2/8, 2/12, 4/6, 4/8

337

GRANDEZZA MOTORE / MOTOR SIZE / MOTOR-BAUGROSSE / TAILLE MOTEUR  
56 - 200L

337

BN

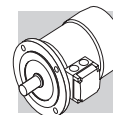
**M14 - VARIANTI E OPZIONI**
**M14 - VARIANTS  
AND OPTIONS**
**M14 - OPTIONEN**
**M14 - VARIANTES  
ET OPTIONS**
**VARIANTI**
**VARIANTS**
**OPTIONEN**
**VARIANTES**

Descrizione / Description Beschreibung / Description		Default / Default Standard / Par défaut	Opzione / Option Option / Option		
Tensione-frequenza Voltage-frequency Spannung-Frequenz Tension-fréquence		230/400-50			291
Grado di protezione Protection class Schutzart Degré de protection	<b>BN</b>	IP 55	IP 56		308
	<b>BN_FD</b> <b>BN_FA</b>	IP 54	IP 55		
	<b>BN_BA</b>	IP 55	-		
Classe di isolamento Insulation class Isolierstoffklasse Classe d'isolation		CL F	CLH		310
Forma costruttiva Design version Bauform Forme de construction		<b>B5</b>	<b>B14</b>	<b>B3</b>	301

**OPZIONI**
**OPTIONS**
**OPTIONEN**
**OPTIONS**

Descrizione / Description Beschreibung / Description	Valori / Catalogue numbers Werte / Valeurs			
Protezioni termiche Thermal protective devices Thermische Wicklungsschutz Protections thermiques	<b>D3</b>	<b>E3</b>		311
Potenza normalizzata a 50 Hz 50 Hz normalized power Auf 50 Hz genormte Leistung Puissance normalisée à 50 Hz	<b>PN</b>			294
Dispositivi di retroazione Feedback devices Signalrückführungen ( Drehgeber ) Dispositifs de rétroaction	<b>EN1</b>	<b>EN2</b>	<b>EN3</b>	313
Riscaldatori anticondensa Anti-condensate heaters Wicklungsheizung Réchauffeurs anticondensation	<b>H1</b>			314
Tropicalizzazione avvolgimenti Tropicalized windings Tropenschutz der Motorwicklungen Tropicalisation bobinages	<b>TP</b>			314
Doppia estremità d'albero Double-extended shaft Zweites Wellenende Arbre à double extrémité	<b>PS</b>			314
Equilibratura rotore in grado B Rotor balancing grade B Rotorauswuchtung mit Grad B Equilibrage rotor en degré B	<b>RV</b>			315
Protezioni meccaniche esterne External mechanical protections Schutzdächer Protections mécaniques extérieures	<b>RC</b>	<b>TC</b>		316
Ventilazione forzata Forced ventilation Fremdlüfter Ventilation forcée	<b>U1</b>	<b>U2</b>		305
Esecuzione certificata Certification Zertifizierte Ausführung Exécution certifiée		<b>CUS</b>		295
China Compulsory Certification		<b>CCC</b>		296











**OPZIONI COLLEGATE  
AL FRENO**

**BRAKE-RELATED OPTIONS**

**BREMSEOPTIONEN**

**OPTIONS CONCERNANT  
LE FREIN**

Descrizione <i>Description</i> Beschreibung / <i>Description</i>	Valori / <i>Catalogue numbers</i> Werte / <i>Valeurs</i>				Pagina / <i>Page</i> Seite / <i>Page</i>
Coppia frenante <i>Brake torque</i> Bremsmoment <i>Couple de freinage</i>	Riferirsi al particolare tipo di freno <i>Refer to brake type</i> Bezug auf den entsprechenden Bremstyp nehmen <i>Se référer au type de frein particulier</i>				 327  331  335
Leva di sblocco manuale <i>Manual release lever</i> Manueller Bremsl�fthebel <i>Clevier de d�blocage manuel</i>	<b>R</b>	<b>RM</b>			 318
Orientamento leva di sblocco <i>Release lever orientation</i> Orientierung des Bremsl�sehebel <i>Orientation levier de d�blocage</i>	<b>AB</b>	<b>AA</b>	<b>AC</b>	<b>AD</b>	
Alimentatore freno d.c. <i>DC brake rectifier</i> Stromversorgung der Bremse <i>Disp. d'alimentation c.c.</i>	<b>NB</b>	<b>NBR</b>	<b>SB</b>	<b>SBR</b>	 325
Volano per avviamento progressivo <i>Soft-start flywheel</i> Schwungrad f�r Sanftanlauf <i>Volant pour d�marrage progressif</i>	<b>F1</b>				 322
Filtro capacitivo <i>Capacitive filter</i> Kapazitiver Filter <i>Filtre capacitif</i>	<b>CF</b>				 322
Alimentazione freno separata (*) <i>Brake separate power supply (*)</i> Separate Bremsversorgung (*) <i>Alimentation frein s�par�e (*)</i>	<b>...SA</b>	<b>...SD</b>			 320

(\*) Completare con il valore di tensione.

(\*) Specify voltage.

(\*) Spannungswert eintragen.

(\*) Compl ter avec la valeur de tension.



Valori pre-impostati di default.



Default values.



Standardwerte bei Lieferung falls nicht anders spezifiziert.



Valeurs pr d finies par d faut.

**M15 - GRADO DI PROTEZIONE**

**M15 - DEGREE  
OF PROTECTION**

**M15 - SCHUTZART**

**M15 - DEGRE  
DE PROTECTION**



Nella loro esecuzione standard (non autofrenante) i motori tipo BN sono caratterizzati dal grado di protezione IP55, a richiesta   disponibile la protezione aumentata IP56.

I motori autofrenanti tipo BN\_FD e BN\_FA sono protetti in grado IP54 e, opzionalmente, in IP55. La tabella sottostante riassume la disponibilit  dei vari gradi di protezione.

Indipendentemente dal grado di protezione specificato, per installazione all'aperto i motori devono essere protetti dall'irraggiamento diretto e, nel caso di installazione con l'albero rivolto verso il basso,   necessario specificare ulteriormente il tettuccio di protezione contro l'ingresso di acqua e di corpi solidi (opzione **RC**).

Standard BN motors (where standard means other than brake motors) are manufactured in protection class IP55. A higher protection class IP56 is available at request. Brake motors type BN\_FD and BN\_FA are in protection class IP54 or IP55 (at request).

Brake motors BN\_BA are only available in protection class IP55. The following table provides an overview of available protection classes.

Regardless of the protection class specified on order, motors to be installed outdoors require protection against direct sunlight and in addition – when they are to be installed with the shaft pointing downwards – a rain canopy to keep out water and solid bodies (option **RC**).

In der Standardausf hrung (ohne Bremse) werden die Motoren vom Typ BN in Schutzart IP55 ausgeliefert. Auf Anfrage k nnen sie mit einer auf IP56 erh hten Schutzart geliefert werden. Die Bremsmotoren vom Typ BN\_FD und BN\_FA verf gen  ber die Schutzart IP54 und k nnen Optional in IP55 geliefert werden. Die Bremsmotoren vom Typ BN\_BA sind nur in der Schutzart IP55 lieferbar. In der nachstehenden Tabelle werden die jeweils zur Verf gung stehenden Schutzarten zusammengefasst. Unabh ngig von der spezifischen Schutzart m ssen die im Freien installierten Motoren vor direkten Strahlungen gesch tzt werden. Im Fall einer senkrechten Montage, in der die Welle nach unten gerichtet ist, sollte dar ber hinaus das Schutzdach bestellt werden, das vor dem Eindringen von Wasser und festen Fremdk rpern sch tzt (Option **RC**).

Dans l'ex cution standard (non frein), les moteurs type BN sont caract ris s par le degr  de protection IP55. Sur demande, la protection major e IP56 est aussi disponible. Les moteurs frein type BN\_FD et BN\_FA sont prot g s en degr  IP54 et, en option, en IP55. Les moteurs frein type BN\_BA sont disponibles uniquement avec degr  de protection IP55. Le tableau ci-dessous r sume la disponibilit  des diff rents degr s de protection. Ind pendamment du degr  de protection sp cifi , en cas d'installation en plein air, les moteurs doivent  tre prot g s des rayons directs du soleil et, en cas d'installation avec arbre dirig  vers le bas, il est n cessaire de sp cifier ult rieurement le capot de protection contre la p n tration de l'eau et des corps solides (option **RC**).

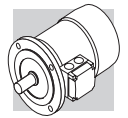

(24)

	IP 54	IP 55	IP 56
BN		standard	
BN_FD BN_FA	standard		
BN_BA		standard	

IP		5	5
<b>0</b>		Non protetto Not protected Nicht geschützt Non protégé	<b>0</b>
<b>1</b>		Protetto contro corpi solidi estranei di $\phi \geq 50$ mm Protected against extraneous solid bodies having $\phi \geq 50$ mm Geschützt gegen feste Fremdkörper mit $\phi \geq 50$ mm Protégé contre les corps solides étrangers de $\phi \geq 50$ mm	<b>1</b>
<b>2</b>		Protetto contro corpi solidi estranei di $\phi \geq 12.5$ mm Protected against extraneous solid bodies having $\phi \geq 12.5$ mm Geschützt gegen feste Fremdkörper mit $\phi \geq 12,5$ mm Protégé contre les corps solides étrangers de $\phi \geq 12.5$ mm	<b>2</b>
<b>3</b>		Protetto contro corpi solidi estranei di $\phi \geq 2.5$ mm Protected against extraneous solid bodies having $\phi \geq 2.5$ mm Geschützt gegen feste Fremdkörper mit $\phi \geq 2,5$ mm Protégé contre les corps solides étrangers de $\phi \geq 2.5$ mm	<b>3</b>
<b>4</b>		Protetto contro corpi solidi estranei di $\phi \geq 1.0$ mm Protected against extraneous solid bodies having $\phi \geq 1.0$ mm Geschützt gegen feste Fremdkörper mit $\phi \geq 1,0$ mm Protégé contre les corps solides étrangers de $\phi \geq 1.0$ mm	<b>4</b>
<b>5</b>		Protetto contro la polvere Protected against dust Staubgeschützt Protégé contre la poussière	<b>5</b>
<b>6</b>		Nessun ingresso di polvere No dust ingress Kein Staubeintritt Protection absolue contre la poussière	<b>6</b>
			<b>7</b>
			<b>8</b>

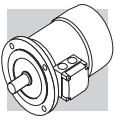

# CLF

I motori di produzione Bonfiglioli impiegano, di serie, materiali isolanti (filo smaltato, isolanti, resine d'impregnazione) in classe **F**.

In genere, per i motori in esecuzione standard la sovratemperatura dell'avvolgimento statore è contenuta entro il limite di 80 K, corrispondente alla sovratemperatura di classe B.

L'accurata scelta dei componenti del sistema isolante consente l'impiego dei motori anche in climi tropicali ed in presenza di vibrazioni normali.

Per applicazioni in presenza di sostanze chimiche aggressive o di elevata umidità, è consigliabile contattare il Servizio Tecnico Bonfiglioli per la selezione del prodotto più idoneo.

*Bonfiglioli motors use class F insulating materials (enamelled wire, insulators, impregnation resins) as compare to the standard motor.*

*In standard motors, stator windings over temperature normally stays below the 80 K limit corresponding to class B over temperature.*

*A careful selection of insulating components makes the motors compatible with tropical climates and normal vibration.*

*For applications involving the presence of aggressive chemicals or high humidity, contact Bonfiglioli Engineering for assistance with product selection.*

Die Motoren von Bonfiglioli sind serienmäßig mit Isolierstoffen (Emaildraht, Isolierstoffen, Imprägnierharzen) der Klasse **F** ausgestattet.

Allgemein hält sich die Übertemperatur der Motoren in der Standardausführung innerhalb des Grenzwerts von 80 K, der einer Übertemperatur der Klasse B entspricht. Die sorgfältig Wahl der Komponenten des Isoliersystem gestatten den Einsatz dieser Motoren auch unter tropischen Klimabedingungen und bei Vorliegen normaler Schwingungen.

Für den Einsatz in in der Nähe aggressiv wirkenden chemischen Substanzen oder bei hoher Luftfeuchtigkeit, wird empfohlen sich zur Wahl eines passenden Produktes mit unserem Technischen Kundendienst in Verbindung zu setzen.

*De série, les moteurs fabriqués par Bonfiglioli utilisent des matériaux isolants (fil émaillé, isolants, résines d'impregnation) en classe F.*

*En général, pour les moteurs en exécution standard, l'échauffement de l'enroulement du stator se situe dans la limite de 80 K, correspondant à un échauffement de classe B.*

*Le choix soigné des composants du système d'isolation permet d'utiliser également les moteurs dans des climats tropicaux et en présence de vibrations normales.*

*Pour des applications en présence de substances chimiques agressives, ou d'humidité élevée, il est conseillé de contacter le Service Technique Bonfiglioli pour sélectionner le produit le plus adapté.*

# CLH

Su richiesta può venire specificata la classe di isolamento **H**.

*Motors manufactured in insulation class H are available at request.*

Auf Anfrage können sie auch in der Klasse **H** geliefert werden.

*Sur demande, la classe d'isolation H peut être spécifiée.*

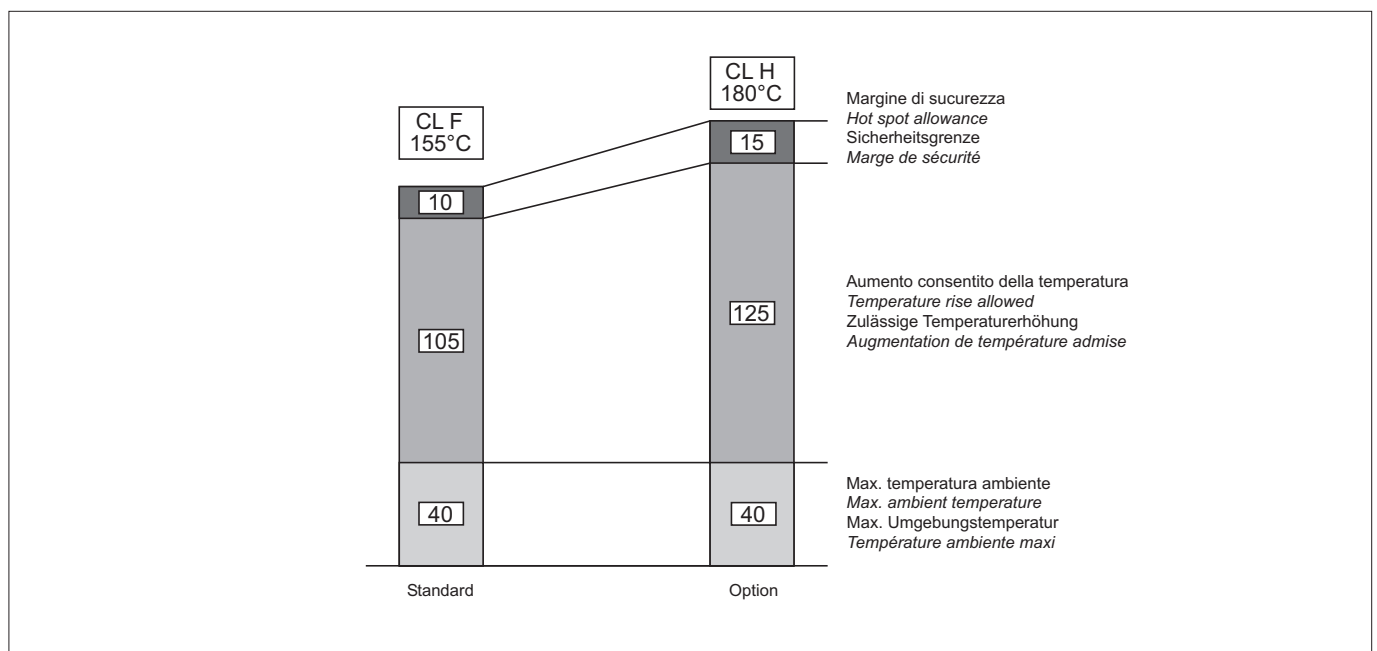





## M17- PROTEZIONI TERMICHE

## M17- THERMAL PROTECTIVE DEVICES

## M17- THERMISCHE WICKLUNGSSCHUTZEINRICHTUNGEN

## M17- PROTECTIONS THERMIQUES

Oltre alla protezione garantita dall'interruttore magnetotermico, i motori possono essere provvisti di sonde termiche incorporate per proteggere l'avvolgimento da eccessivo riscaldamento dovuto alla scarsa ventilazione o servizio intermittente. Una protezione aggiuntiva di questo tipo dovrebbe sempre essere specificata per i motori dotati di ventilazione separata. Le varianti a disposizione sono:

*The standard thermal cut out fitted to motors may be supplemented by incorporating thermistors or thermostats to protect winding from overheating due to poor ventilation or intermittent duty.*

*Such additional protection is highly recommended for motors with separate ventilation. Available variants are as follows:*

Abgesehen vom durch den Magnetwärmeschalter garantierten Schutz können die Motoren mit integrierten. Temperaturfühler ausgestattet werden, die die Wicklung vor Überhitzung aufgrund einer unzureichenden Lüftung oder eines Aussetzbetriebs sichern. Ein solcher zusätzlicher Schutz sollte bei Motoren mit Fremdlüftung immer verwendet werden. Die verfügbaren Optionen sind:

*Outre la protection garantie par le thermocontact moteur, les moteurs peuvent être équipés de sondes thermiques incorporées pour protéger le bobinage contre une surchauffe excessive due à une faible ventilation ou un service intermittent.*

*Ce type de protection supplémentaire devrait toujours être prévue pour les moteurs dotés de ventilation séparée. Les variantes à disposition sont les suivantes :*

### D3

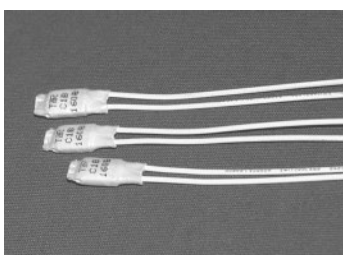

**n° 3 sonda bimetalliche negli avvolgimenti con temperatura 150 °C**

**3 Bi-metallic thermostats in the windings, 150 °C temperature**

**3 Bimetallfühler in den Wicklungen mit einer Ansprechtemperatur von 150 °C**

**n° 3 sondes bimétalliques dans les bobinages avec température de 150 °C**

I protettori di questo tipo contengono all'interno di un involucro un disco bimetallico che, raggiunta la temperatura nominale di intervento (150 °C), commuta i contatti dalla posizione di riposo. Con la diminuzione della temperatura, il disco e i contatti riprendono automaticamente la posizione di riposo.

Normalmente si impiegano tre sonde bimetalliche in serie con contatti normalmente chiusi e terminali disponibili in una morsettiera ausiliaria.

*Bimetallic thermostats consist of a bimetallic disc mounted inside a casing. Upon reaching the preset operating temperature (150 °C), the disc operates the contacts causing them to disengage from the rest position.*

*As temperature decreases, disc and contacts return to the rest position.*

*Normally, three bimetallic thermostats connected in series with normally closed contacts and an auxiliary terminal board are used.*

Diese Schutzeinrichtungen enthalten in einer Kapsel eine Bimetallscheibe, die bei Erreichen der Nennansprechtemperatur (150 °C) die Kontakte aus ihrer Ruhestellung heraus schaltet. Bei abnehmender Temperatur nehmen die Scheibe und die Kontakte automatisch wieder ihre Ruhestellung ein. Normalerweise werden diese drei Bimetallfühler bei normal geschlossenen Kontakten und auf einer Hilfsklemmenleiste verfügbaren Anschlüsse in Reihe geschaltet.

*Les protecteurs de ce type contiennent, dans une enveloppe interne, un disque bimétallique qui, lorsque la température nominale d'intervention (150 °C) est atteinte, commute les contacts de la position de repos.*

*Avec la diminution de la température, le disque et les contacts reprennent automatiquement la position de repos.*

*Normalement, on utilise trois sondes bimétalliques en série avec contacts normalement fermés et extrémités disponibles dans une boîte à bornes auxiliaire.*

### E3

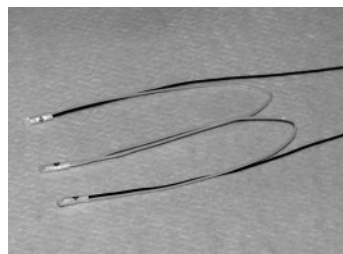

**n° 3 termistori PTC negli avvolgimenti, con temperatura 150 °C**

**3 PTC thermistors in the windings, 150 °C temperature**

**3 PTC-Thermistoren in den Wicklungen mit einer Ansprechtemperatur 150 °C**

**3 thermistors PTC dans les bobinages, avec température de 150 °C**

I termistori sono semiconduttori che presentano una rapida variazione di resistenza in prossimità della temperatura nominale d'intervento (150 °C). In genere sono impiegati termistori a coefficiente di temperatura positivo, anche conosciuti con la sigla PTC.

*Thermistors are semiconductors that exhibit a rapid resistance change when approaching a preset switch temperature (150 °C). Normally, positive temperature coefficient (PTC) thermistors are used.*

Bei diesen Thermistoren handelt es sich um Halbleiter, die eine schnelle Änderung des Widerstands kurz vor der Nennansprechtemperatur (150 °C) aufweisen. Im allgemeinen werden Thermistoren mit positivem Temperaturkoeffizienten verwendet, die auch unter der Bezeichnung PTC bekannt sind.

*Les thermistors sont des semi-conducteurs qui présentent une variation rapide de résistance à proximité de la température nominale d'intervention (150 °C). En général, on utilise des thermistors à coefficient de température positif, connus aussi sous le sigle PTC.*

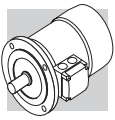

Questi sensori presentano il vantaggio di avere ingombri ridotti, un tempo di risposta molto contenuto e la totale assenza di usura. A differenza delle sonde termiche bimetalliche i termistori non possono comandare direttamente i relais e devono pertanto essere collegati ad una particolare apparecchiatura di sgancio.  
I terminali di 3 PTC collegati in serie, sono disponibili in una morsettiera ausiliaria.

*These sensors offer such advantages as a compact, space-efficient design, very low response time and totally wear-free operation. Unlike bi-metallic thermostats, thermistors do not operate the relays directly and need to be connected to a special release device for this purpose. The terminals for three PTC thermistors connected in series are available in an auxiliary terminal board.*

Diese Sensoren haben den Vorteil kleiner Abmessungen, einer stark eingehaltenen Ansprechzeit und weisen keinerlei Verschleißerscheinungen auf. Im Unterschied zu Bimetall-Temperaturfühlern können diese Thermistoren die Relais nicht direkt schalten und müssen daher an ein spezielles Auslösegerät angeschlossen werden. Die Anschlüsse der 3 in Reihe geschalteten PTC-Thermistoren sind an einer Zusatzklemmleiste verfügbar.

*Ces capteurs présentent l'avantage d'être de dimensions réduites, leur temps de réponse est très limité et l'absence d'usure est totale. A la différence des sondes thermiques bimétalliques, les thermistors ne peuvent pas commander directement les relais, par conséquent, ils doivent être branchés à un appareil de déclenchement particulier. Les extrémités de 3 PTC reliés en série sont disponibles dans une boîte à bornes auxiliaire.*

**M18 - DISPOSITIVI DI RETROAZIONE**

**M18 - FEEDBACK UNITS**

**M18 - ENCODER / INKREMENTALGEBER**

**M18 - DISPOSITIFS DE RETROACTION**

**EN1, EN2, EN3**

<b>BN 63...BN 200L</b>
<b>BN 63_FD...BN 200L_FD</b>
<b>BN 63_FA...BN 200L_FA</b>

**EN\_ + U1**

	<b>L3</b>
<b>BN 160M...BN 180M</b>	72
<b>BN 180L...BN 200L</b>	82
<b>BN 160M_FD...BN 180M_FD</b>	35
<b>BN 180L_FD...BN 200L_FD</b>	41

Se l'opzione EN\_ è richiesta per motori di grandezza BN71...BN160MR, contemporaneamente all'opzione U1/U2, le variazioni dimensionali coincidono con quelle dell'opzione U1/U2.

*If the encoder device (options EN1, EN2, EN3) is specified on motors BN71...BN160MR, along with the independent fan cooling (options U1, U2), the extra length of motor is coincident with that of the correspondent U1 and U2 execution.*

Wenn der Encoder (Optionen EN1, EN2, EN3) für Motoren der Baugrößen BN71...BN160MR zusammen mit Fremdlüftung (Optionen U1, U2) ausgelegt ist, stimmen die Maßänderungen des Motors mit jenen der entsprechenden Ausführungen U1 und U2 überein.

*Si un codeur (option EN1, EN2, EN3) est nécessaire sur les moteurs de tailles BN71...BN160MR, en association avec la ventilation forcée (options U1, U2), la variation de dimensions du moteur coïncide avec celle des exécutions U1 et U2 correspondantes.*



## EN1

Encoder incrementale,  $V_{IN}=5$  V, uscita line-driver RS 422.    *Incremental encoder,  $V_{IN}=5$  V, line-driver output RS 422.*    Inkremental-Encoder,  $V_{IN}=5$  V, Ausgang "line-driver" RS 422.    *Codeur incrémental,  $V_{IN}=5$  V, sortie line-driver RS 422.*

## EN2

Encoder incrementale,  $V_{IN}=10-30$  V, uscita line driver RS 422.    *Incremental encoder,  $V_{IN}=10-30$  V, line-driver output RS 422.*    Inkremental-Encoder,  $V_{IN}=10-30$  V, Ausgang "line-driver" RS 422.    *Codeur incrémental,  $V_{IN}=10-30$  V, sortie line-driver RS 422.*

## EN3

Encoder incrementale,  $V_{IN}=12-30$  V, uscita push-pull 12-30 V.    *Incremental encoder,  $V_{IN}=12-30$  V, push-pull output 12-30 V.*    Inkremental-Encoder,  $V_{IN}=12-30$  V, Ausgang "push-pull" 12-30 V.    *Codeur incrémental,  $V_{IN}=12-30$  V, sortie push-pull 12-30 V.*

### Tabella dati tecnici

### Specifications

### Technische Daten

### Tableau des caractéristiques techniques

(25)		EN1	EN2	EN3
Interfaccia <i>Interface</i> Schnittstelle <i>Interface</i>		RS 422	RS 422	push-pull
Tensione alimentazione <i>Power supply voltage</i> Versorgungsspannung <i>Tension d'alimentation</i>	[V]	4...6	10...30	12...30
Tensione di uscita <i>Output voltage</i> Ausgangsspannung <i>Tension de sortie</i>	[V]	5	5	12...30
Corrente di esercizio senza carico <i>No-load operating current</i> Betriebsstrom ohne Belastung <i>Courant d'utilisation sans charge</i>	[mA]	120	100	100
N° impulsi per giro <i>No. of pulses per revolution</i> Impulse pro Drehung <i>Nombre d'impulsions par tour</i>		1024		
n° segnali <i>No. of signals</i> Signale <i>Nombre de signaux</i>		6 (A,B,C + Segnali invertiti / + <i>Inverted signals</i> Invertierte Signale / <i>Signaux inversés</i> )		
Max. frequenza di uscita <i>Max. output frequency</i> Max. Ausgangsfrequenz <i>Fréquence max. de sortie</i>	[kHz]	600		
Max. velocità <i>Max. speed</i> Max. Drehzahl <i>Vitesse max.</i>	[min <sup>-1</sup> ]	6000 (9000 min <sup>-1</sup> per 10 s ) 6000 (9000 rpm for 10 s) 6000 (9000 min <sup>-1</sup> pour 10 s) 6000 (9000 min <sup>-1</sup> für 10 Sek.)		
Campo di temperatura <i>Temperature range</i> Temperaturbereich <i>Plage de température</i>	[°C]	-30 ... +100		
Grado di protezione <i>Protection class</i> Schutzgrad <i>Degré de protection</i>		IP 65		



**M19 - RISCALDATORI ANTICONDENSA**

I motori funzionanti in ambienti molto umidi e/o in presenza di forti escursioni termiche, possono essere equipaggiati con una resistenza anticondensa. L'alimentazione monofase è prevista da morsettiera ausiliaria posta nella scatola principale.

**M19 - ANTI-CONDENSATION HEATERS**

Where an application involves high humidity or extreme temperature fluctuation, motors may be equipped with an anti-condensate heater. A single-phase power supply is available in the auxiliary terminal board inside the main terminal box.

**M19 - WICKLUNGSHEIZUNG**

Die Motoren, die in besonders feuchten Umgebungen und/oder unter starken Temperaturschwankungen eingesetzt werden, können mit einem Heizelement als Kondenwasserschutz ausgestattet werden. Die einphasige Versorgung erfolgt über eine Zusatzklemmenleiste, die sich im Klemmenkasten befindet.

**M19 - RECHAUFFEURS ANTICONDENSATION**

Les moteurs fonctionnant dans des milieux très humides et/ou en présence de fortes plages thermiques peuvent être équipés d'une résistance anticondensation. L'alimentation monophasée est prévue par l'intermédiaire d'une boîte à bornes auxiliaire située dans la boîte principale.

**H1**

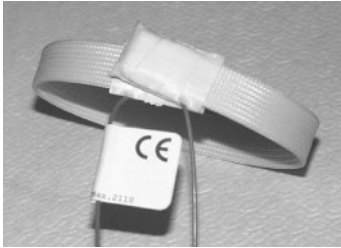

	<b>H1</b>
	1~ 230V ± 10% <b>P [W]</b>
<b>BN 56 ... BN 80</b>	10
<b>BN 90 ... BN 160MR</b>	25
<b>BN 160M ... BN 180M</b>	50
<b>BN 180L ... BN 200L</b>	50



Durante il funzionamento del motore la resistenza anticondensa non deve mai essere alimentata.



Always remove power supply to the anti-condensate heater before operating the motor.



Während des Motorbetriebs darf die Wicklungsheizung nie gespeist werden.



Durant le fonctionnement du moteur, la résistance anticondensation ne doit jamais être alimentée.

**M20 - TROPICALIZZAZIONE**

**M20 - TROPICALIZATION**

**M20 - TROPENSCHUTZ**

**M20 - TROPICALISATION**

**TP**

Su richiesta, mediante la specifica dell'opzione TP, gli avvolgimenti del motore ottengono una protezione aggiuntiva che li rende idonei al funzionamento in condizioni di elevata temperatura e umidità.

When option TP is specified, motor windings receive additional protection for operation in high humidity and temperature conditions.

Wird die Option TP bestellt, wird die Motorwicklung mit einem zusätzlichen Schutz ausgestattet, der ihren Einsatz unter hohen Temperaturen und starker Feuchtigkeit ermöglicht.

Sur demande, en spécifiant l'option TP, les bobinages du moteur obtiennent une protection supplémentaire qui les rend apte au fonctionnement dans des conditions de température et d'humidité élevées.

**M21 - ESECUZIONI ALBERO**

**M21 - ROTOR SHAFT CONFIGURATIONS**

**M21 - OPTIONEN DER ROTORWELLE**

**M21 - EXECUTIONS ARBRE ROTOR**

**PS**

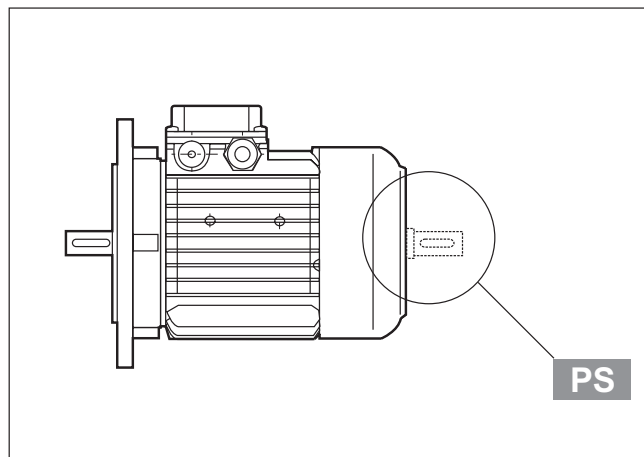

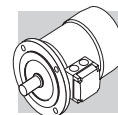

### Seconda estremità d'albero

L'opzione esclude le varianti RC, TC, U1, U2, EN1, EN2, EN3 – non applicabile ai motori con freno tipo BA.

Le dimensioni sono reperibili nelle tavole dimensionali dei motori.

### Second shaft extension

*This option is not compatible with variants RC, TC, U1, U2, EN1, EN2, EN3 – and is not feasible on motors equipped with BA brake.*

*For shaft dimensions please see motor dimensions tables.*

### Zweites Wellenende

Diese Option schließt die Optionen RC, TC, U1, U2, EN1, EN2, EN3 aus – sie kann nicht außerdem nicht an Motoren, die mit einer Bremse vom Typ BA ausgestattet sind, angebaut werden. Die entsprechenden Maße können den Maßtabellen der Motoren entnommen werden.

### Arbre à double extrémité

*L'option exclut les variantes RC, TC, U1, U2, EN1, EN2, EN3 – non applicables aux moteurs avec frein type BA.*

*Les dimensions figurent sur les planches de dimensions des moteurs.*

### M22 - EQUILBRATURA ROTORE

I motori sono equilibrati dinamicamente con mezza linguetta e rientrano nel grado di vibrazione **N**, secondo la Norma CEI EN 60034-14.

### M22 - ROTOR BALANCING

*Motors are dynamically balanced with a half key and fall within vibration class **N** in accordance with standard CEI EN 60034-14.*

### M22 - ROTORAUSWUCHTUNG

Die Motoren werden dynamisch durch das Einsetzen eines halben Federkeils ausgewuchtet und fallen der Norm CEI EN 60034-14 gemäß unter die Einstufung **N** des Schwingungsgrads.

### M22 - EQUILIBRAGE DU ROTOR

*Les moteurs sont équilibrés du point de vue dynamique avec une demi-clavette et rentrent dans le degré de vibration **N**, selon la norme CEI EN 60034-14.*

## RV

Per esigenze di particolare silenziosità è disponibile l'esecuzione opzionale **RV** che garantisce vibrazioni ridotte, secondo il grado **B**.

La tabella sottostante riporta i valori della velocità efficace di vibrazione per equilibratura standard (A) e incrementata (B).

*Where low noise is a priority requirement, the option **RV** ensures reduced vibration in accordance with vibration class **B**.*

*Table below shows the value for the vibration velocity for standard (A) and improved (B) balancing.*

Sollte eine besondere Laufruhe gefordert werden, steht als Option **RV** eine Ausführung mit reduziertem Schwingverhalten nach Grad **B**, zur Verfügung.

Die folgende Tabelle führt die Werte der Ist-Schwingungsgeschwindigkeit für einen normalen (A) und verbesserten (B) Ausgleich auf.

*En cas d'exigence particulière de faible niveau de bruit, l'exécution **RV** est disponible en option, elle garantit des vibrations réduites, de degré **B**.*

*Le tableau ci-dessous indique les valeurs de la vitesse efficace de vibration pour un équilibrage standard (A) et améliorée (B).*

(26)

Grado di vibrazione Vibration class Schwingungsklasse Degré de vibration	Velocità di rotazione Synchronous speed Drehungsgeschwindigkeit Vitesse de rotation	Limiti della velocità di vibrazione Limits of the vibration velocity Grenzen der Schwingungsgeschwindigkeit Limites de la vitesse de vibration (mm/s)
	n [min <sup>-1</sup> ]	<b>BN 56 &lt; H ≤ BN 200</b>
<b>A</b>	600 < n < 3600	1.6
<b>B</b>	600 < n < 3600	0.70

I valori si riferiscono a misure con motore liberatamente sospeso e funzionamento a vuoto; tolleranza ±10%.

*Values are obtained from measurements on freely suspended motor during no-load operation; tolerance ± 10%.*

Diese Werte beziehen sich auf einem frei hängenden und sich im Leerbetrieb befindlichen Motor; Toleranz ± 10%.

*Les valeurs se réfèrent à des mesures avec moteur librement suspendu et fonctionnement à vide, tolérance ± 10%.*



**M23 - PROTEZIONI  
MECCANICHE  
ESTERNE**

**M23 - EXTERNAL  
MECHANICAL  
PROTECTIONS**

**M23 - MECHANISCHE  
SCHUTZVORRICHTUNGEN**

**M23 - PROTECTIONS  
MECANIQUES  
EXTERIEURES**

**RC**

Il dispositivo parapioggia, che è raccomandato quando il motore è montato verticalmente con l'albero verso il basso, serve a proteggere il motore stesso dall'ingresso di corpi solidi e dallo stillicidio. Le dimensioni aggiuntive sono indicate nella tabella (27).

Il tettuccio esclude le varianti PS, EN1, EN2, EN3 e non è applicabile ai motori con freno tipo BA.

*The rain canopy protects the motor from dripping and avoids the ingress of solid matter. It is recommended when motor is installed in a vertical position with the shaft pointing downwards.*

*Relevant dimensions are indicated in the table (27).*

*The rain canopy is not compatible with variants PS, EN1, EN2, EN3 and will not fit motors equipped with a BA brake.*

Ein Regenschutzdach, dessen Montage empfohlen wird, wenn der Motor senkrecht mit einer nach unten gerichteten Welle montiert wird. Es dient dem Schutz des Motors vor dem Eindringen von festen Fremdkörpern und Tropfwasser. Die Dimensionen werden in der Tabelle (27) angegeben. Das Schutzdach schließt die Möglichkeit der Optionen PS, EN1, EN2, EN3 aus und kann bei Bremsmotoren vom Typ BN\_BA nicht montiert werden.

*Le capot de protection antipluie est recommandé lorsque le moteur est monté verticalement avec l'arbre vers le bas, il sert à protéger le moteur contre l'introduction de corps solides et le suintement. Les dimensions à ajouter sont indiquées dans le tableau (27).*

*Le capot antipluie exclue les variantes PS, EN1, EN2, EN3 et n'est pas applicable aux moteurs avec frein type BA.*

(27)

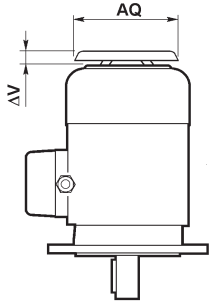
	<b>AQ</b>	<b>Δ V</b>	
<b>BN 63</b>	118	24	
<b>BN 71</b>	134	27	
<b>BN 80</b>	152	25	
<b>BN 90</b>	168	30	
<b>BN 100</b>	190	28	
<b>BN 112</b>	211	32	
<b>BN 132 ... BN 160MR</b>	254	32	
<b>BN 160M ... BN 180M</b>	302	36	
<b>BN 180L ... BN 200L</b>	340	36	

**TC**

La variante del tettuccio tipo TC è da specificare quando il motore è installato in ambienti dell'industria tessile, dove sono presenti filamenti che potrebbero ostruire la griglia del copriven-tola, impedendo il regolare flusso dell'aria di raffreddamento.

L'opzione esclude le varianti EN1, EN2, EN3 e non è applicabile ai motori con freno tipo BA.

L'ingombro complessivo è lo stesso del tettuccio tipo RC.

*Option TC is a rain canopy variant for textile industry environments, where lint may obstruct the fan grid and prevent a regular flow of cooling air.*

*This option is not compatible with variants EN1, EN2, EN3 and will not fit motors equipped with a BA brake.*

*Overall dimensions are the same as rain canopy type RC.*

Bei dieser Option handelt es sich um ein Schutzdach mit einem Textilnetz, dessen Einsatz empfohlen wird wenn der Motor in Bereichen der Textilindustrie installiert wird, in denen Stofffusseln das Lüfterradgitter verstopfen und so einen ausreichenden Kühlluftfluss verhindern könnten. Diese Option schließt die Möglichkeit der Optionen EN1, EN2, EN3 aus und kann bei Bremsmotoren vom Typ BN\_BA nicht montiert werden.

Die Gesamtmaße entsprechen denen des Schutzdachs vom Typ RC.

*La variante du capot type TC est à spécifier lorsque le moteur est installé dans des sites de l'industrie textile, où sont présents des filaments qui pourraient obstruer la grille du cache-ventilateur et empêcher le flux régulier de l'air de refroidissement. L'option exclue les variantes EN1, EN2, EN3 et n'est pas applicable aux moteurs avec frein type BA.*

*L'encombrement total est identique à celui du capot type RC.*

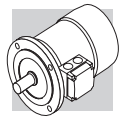

**M24 - MOTORI ASINCRONI  
AUTOFRENANTI**

**M24 - ASYNCHRONOUS  
BRAKE MOTORS**

**M24 - DREHSTROMBREMS-  
MOTOREN**

**M24 - MOTEURS FREIN  
ASYNCHRONES**

**Funzionamento**

L'esecuzione autofrenante prevede l'impiego di freni a pressione di molle alimentati in c.c. (tipo FD) o in c.a. (tipo FA, BA).

Tutti i freni funzionano secondo il principio di sicurezza, ossia intervengono in seguito alla pressione esercitata dalle molle, in mancanza di alimentazione.

**Operation**

Versions with incorporated brake use spring-applied DC (FD option) or AC (FA, BA options) brakes.

All brakes are designed to provide fail-safe operation, meaning that they are applied by spring-action in the event of power failure.

**Betriebsweise**

Die selbstbremsende Ausführung der Motoren sieht den Einsatz von Federdruckbremsen vor, die mit Gleichstrom (Typ FD) oder mit Wechselstrom (Typ FA, BA) gespeist werden. Alle Bremsen arbeiten gemäß dem Sicherheitsprinzip, d.h. sie greifen, im Fall eines Stromausfalls in Folge eines auf die Feder ausgeübten Drucks ein.

**Fonctionnement**

L'exécution avec frein prévoit l'utilisation de freins à pression de ressorts alimentés en c.c. (type FD) ou en c.a. (type FA, BA). Tous les freins fonctionnent selon le principe de sécurité, c'est-à-dire qu'ils interviennent suite à la pression exercée par les ressorts, en cas de coupure d'alimentation.

(28)

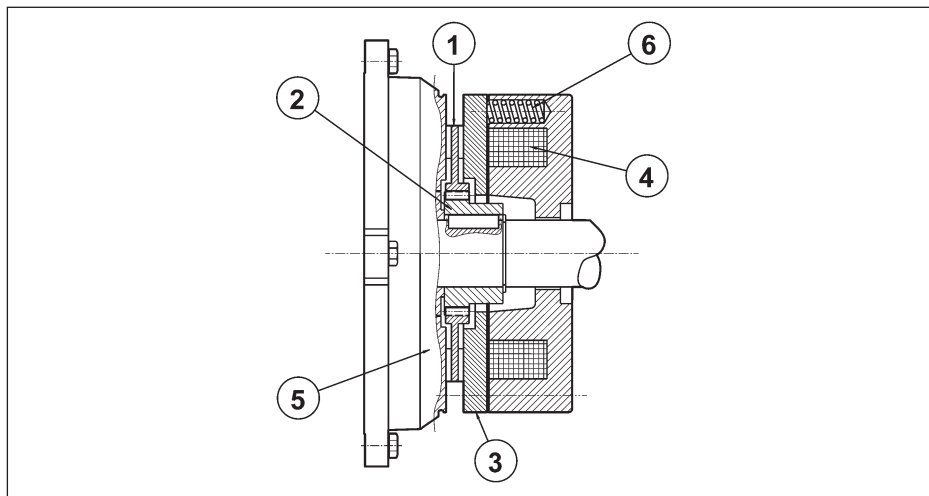

**Legenda:**

- ① disco
- ② mozzo
- ③ áncora mobile
- ④ bobina
- ⑤ scudo NDE motore
- ⑥ molle

**Key:**

- ① brake disc
- ② disc carrier
- ③ pressure plate
- ④ brake coil
- ⑤ motor NDE shield
- ⑥ brake springs

**Zeichenerklärung:**

- ① Brems scheibe
- ② Nabe
- ③ Beweglicher Anker
- ④ Ringspule
- ⑤ Motorschild
- ⑥ Schußfedern

**Légende:**

- ① disque
- ② moyeu d'entraînement
- ③ disque de freinage
- ④ flasque-frein
- ⑤ flasque arrière
- ⑥ ressort de frein

In mancanza di tensione, l'ancora mobile spinta dalle molle di pressione blocca il disco freno tra la superficie dell'ancora stessa e lo scudo motore impedendo la rotazione dell'albero. Quando la bobina viene eccitata, l'attrazione magnetica esercitata sull'ancora mobile vince la reazione elastica delle molle e libera il disco freno, e conseguentemente l'albero motore con esso solidale.

When voltage is interrupted, pressure springs push the armature plate against the brake disc. The disc becomes trapped between the armature plate and motor shield and stops the shaft from rotation. When the coil is energized, a magnetic field strong enough to overcome spring action attracts the armature plate, so that the brake disc – which is integral with the motor shaft – is released.

Wenn die Spannungsversorgung abfällt, sorgt der bewegliche, von den Druckfedern geschobene Anker für die Blockierung der Bremsscheibe zwischen der Ankerfläche und dem Motorschild und blockiert damit den Rotor. Wird die Spule erregt, kommt es durch den magnetischen auf den beweglichen Anker wirkenden Anzug zur Überwindung der elastischen Federkraft und zum Lösen der Bremsscheibe, wodurch der rotor wieder freigegeben wird.

En cas de coupure de courant, l'armature mobile, poussée par les ressorts, bloque le disque de frein entre la surface de l'armature et le bouclier moteur en empêchant la rotation de l'arbre. Lorsque la bobine est excitée, l'attraction magnétique exercée sur l'armature mobile annule la réaction élastique des ressorts et libère le disque de frein, et par conséquent l'arbre moteur, qui est solidaire.

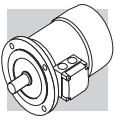

### Caratteristiche generali:

- Coppie frenanti elevate (generalmente  $M_b \cong 2 M_n$ ) e regolabili
- Disco freno con anima in acciaio a doppia guarnizione d'attrito (materiale a bassa usura, senza amianto)
- Cava esagonale sull'albero motore, lato ventola (N.D.E.), per rotazione manuale (non prevista quando sono presenti le opzioni PS, RC, TC, U1, U2, EN1, EN2, EN3)
- Sblocco meccanico manuale (opzioni **R** e **RM** per BN\_FD, BN\_FA).
- Trattamento anticorrosivo di tutte la superfici del freno
- Isolamento in classe F

### Most significant features:

- *High braking torques (normally  $M_b \cong 2 M_n$ ) braking torque adjustment*
- *Steel brake disc with double friction lining (low-wear, asbestos-free lining)*
- *Hexagonal seat on motor shaft fan end (N.D.E.) for manual rotation (not compatible with options PS, RC, TC, U1, U2, EN1, EN2, EN3)*
- *Manual release lever (options **R** and **RM** for BN\_FD, BN\_FA).*
- *Corrosion-proof treatment on all brake surfaces*
- *Insulation class F*

### Allgemeine Eigenschaften:

- Hohe und regulierbare Bremsmomente (allgemein  $M_b \cong 2 M_n$ ).
- Brems Scheibe mit Stahlkern und doppeltem Bremsbelag (Material mit geringem Verschleiß, asbestfrei).
- Sechskant hinten an der Motorwelle, auf Lüfterradseite (N.D.E.), für eine manuelle Drehung des Rotors mit einem Inbusschlüssel. (nicht lieferbar, wenn die Optionen PS, RC, TC, U1, U2, EN1, EN2, EN3) bestellt wurden.
- Manuell zu betätigende, mechanische Bremslüftvorrichtung (Optionen **R** und **RM** für BN\_FD, BN\_FA).
- Korrosionsschutzbehandlung an allen Flächen der Bremse.
- Isolierung in Klasse F.

### Caractéristiques générales:

- *Couples de freinage élevés (généralement  $M_b \cong 2 M_n$ ) et réglables.*
- *Disque de frein avec structure en acier à double garniture de frottement (matière à faible usure, sans amiante).*
- *Empreinte hexagonale sur l'arbre moteur, côté ventilateur (N.D.E.), pour la rotation manuelle (non prévue en cas de présence des options PS, RC, TC, U1, U2, EN1, EN2, EN3).*
- *Débloccage mécanique manuel (options **R** et **RM** pour BN\_FD, BN\_FA).*
- *Traitement anticorrosion sur toute la surface du frein.*
- *Isolation en classe F.*

### M24.1 - LEVA SBLOCCO FRENO

I freni a pressione di molle tipo **FD** e **FA** possono essere dotati opzionalmente di dispositivi per lo sblocco manuale del freno, normalmente utilizzati per condurre interventi di manutenzione sulle parti di macchina, o dell'impianto, comandate dal motore.

### M24.1 - BRAKE RELEASE SYSTEMS

*Spring-applied brakes type **FD** and **FA** may be equipped with optional manual release devices. These are typically used for manually releasing the brake before servicing any machine or plant parts operated by the motor.*

### M24.1 - BREMSLÜFTHEBEL

Die Federdruckbremsen vom Typ **FD** und **FA** können Optional mit Bremslüfthebeln geliefert werden, die ein manuelles Lüften der Bremse ermöglichen. Diese Lüftungseinrichtungen können bei Instandhaltungsarbeiten an vom Motor betriebenen Maschinen- oder Anlagenteilen verwendet werden.

### M24.1 - SYSTEMES DE DEBLOCCAGE FREIN

*Les freins à pression de ressorts type **FD** et **FA** peuvent, en option, être dotés de dispositifs de déblocage manuel du frein, normalement utilisés pour effectuer des interventions d'entretien sur les composants de la machine, ou de l'installation commandée par le moteur.*

**R**

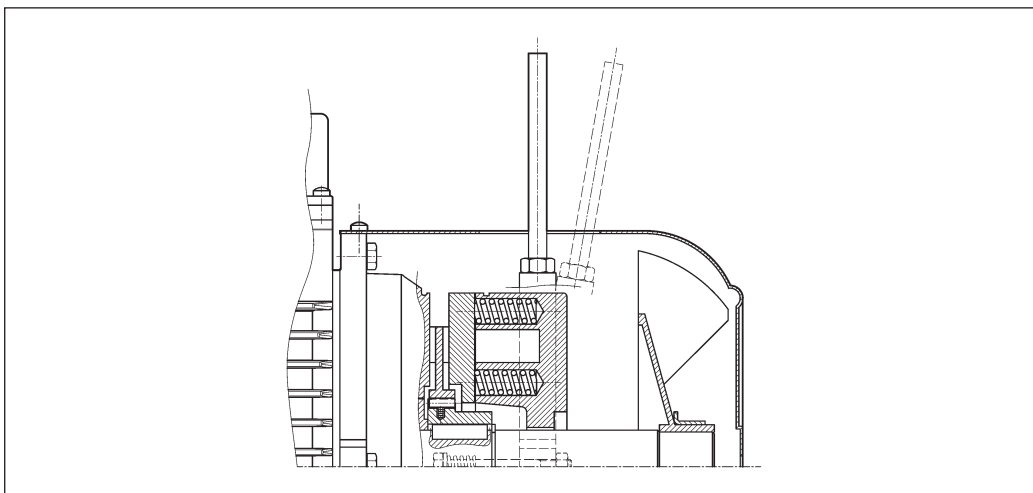

La leva di sblocco è dotata di ritorno automatico, tramite dispositivo a molla.

*A return spring brings the release lever back in the original position.*

Bremslüfthebel mit automatischer Rückstellung durch Federkraft.

*Le levier de déblocage est doté de retour automatique, au moyen d'un dispositif à ressort.*



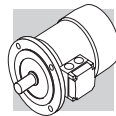

# RM

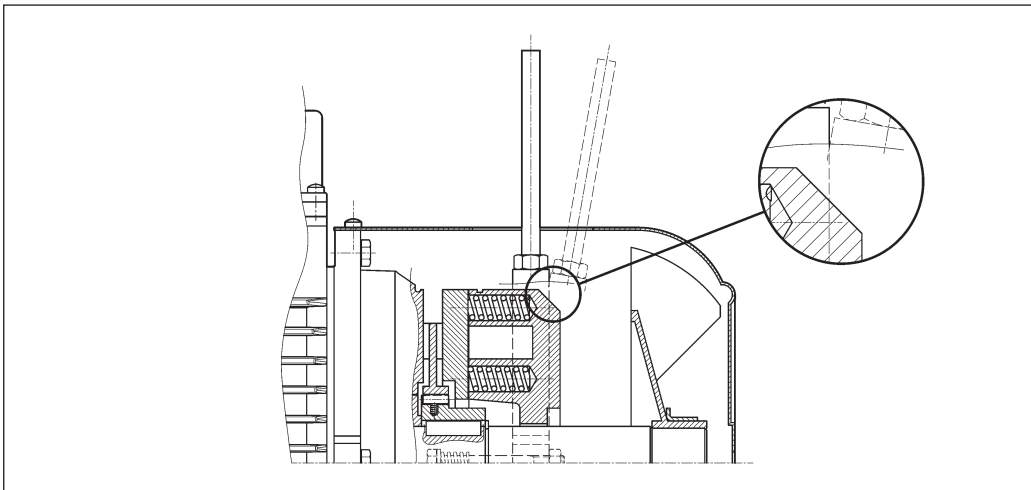

La leva di sblocco può essere temporaneamente bloccata in posizione di rilascio del freno, avvitando la stessa fino ad impegnare l'estremità in un risalto del corpo del freno. La disponibilità dei sistemi di sblocco freno è diversa per i vari tipi di motore, ed è descritta dalla tabella seguente:

*The release lever may be locked in the "release" position by tightening the lever until lever end becomes engaged with a brake housing projection. There are different brake release systems available for the various types of motors as indicated in the table below:*

Der Bremslüfthebel kann zeitweise in der Bremslüftposition arretiert werden, indem man ihn so lange einschraubt, bis die Bremse arretiert ist. Für die unterschiedlichen Motortypen sind ebenso verschiedene Bremslüftsysteme verfügbar, die Sie der folgenden Tabelle entnehmen können:

*Le levier de déblocage peut être temporairement bloqué en position de déblocage du frein en le vissant jusqu'à engager l'extrémité dans une saillie du corps du frein. La disponibilité des systèmes de déblocage du frein est différente en fonction des types de moteur et figure dans le tableau suivant :*

(29)

	R	RM
<b>BN_FD</b>	$63 \leq H \leq 200$	<b>2p</b> 63A2 $\leq H \leq 132$ M2 <b>4p</b> 63A4 $\leq H \leq 132$ MA4 <b>6p</b> 63A6 $\leq H \leq 132$ MA6
<b>BN_FA</b>	$63 \leq H \leq 132$	⊖
<b>BN_BA</b>		



### Orientamento della leva di sblocco

Per entrambe le opzioni **R** e **RM**, la leva di sblocco del freno viene collocata, se non diversamente specificato, con orientamento di 90° in senso orario, rispetto alla posizione della morsettiere - riferimento [AB] nel disegno sottostante. Orientamenti alternativi, tipo [AA], [AC] e [AD] possono essere richiesti citandone la relativa specifica:

### Release lever orientation

*Unless otherwise specified, the release lever is located 90° away from the terminal box – identified by letters [AB] in the diagram below – in a clockwise direction on both options **R** and **RM**.*

*Alternative lever positions [AA], [AC] and [AD] are also possible when the corresponding option is specified:*

### Ausrichtung des Bremslüfthebels

Bei beiden Optionen, **R** und **RM**, wird der Bremslüfthebel, falls nicht anderweitig festgelegt, um 90° im Uhrzeigersinn zur Position des Klemmenkastens montiert (Position [AB] in der nachfolgenden Zeichnung). Andere Positionen: **AA** (0° zum Klemmenkasten), **AC** (180° zum Klemmenkasten) oder **AD** (270° zum Klemmenkasten, im Uhrzeigersinn vom Lüfter aus gesehen) können unter Angabe der entsprechenden Spezifikation bestellt werden:

### Orientation du levier de déblocage

*Pour les deux options **R** et **RM**, le levier de déblocage du frein est positionné, sauf spécification contraire, avec une orientation de 90° dans le sens des aiguilles d'une montre par rapport à la position de la boîte à bornes - référence [AB] sur le dessin ci-dessous. Des orientations différentes, type [AA], [AC] et [AD] peuvent être demandées à condition de préciser la position correspondante :*

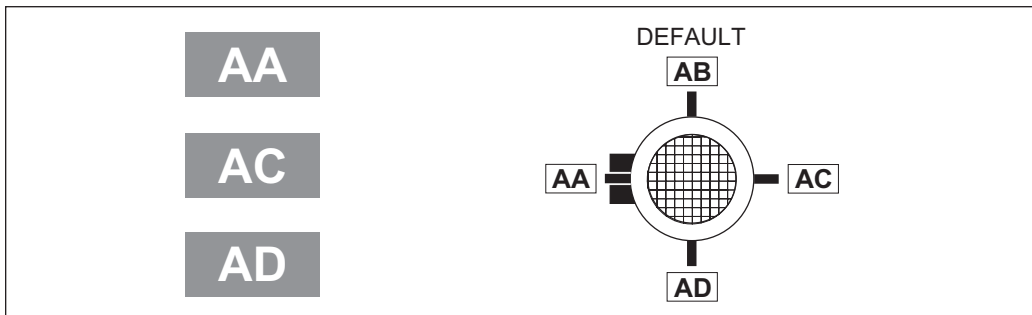

### M24.2 - ALIMENTAZIONE SEPARATA DEL FRENO

#### ...SA

La bobina del freno è alimentata da linea separata e indipendente dall'alimentazione del motore. Il valore di tensione alla bobina deve essere specificato, es. 230SA. L'opzione è applicabile ai motori con freno tipo FD, FA e BA.

### M24.2 - SEPARATE BRAKE SUPPLY

*The brake coil is directly fed through an independent line, separately from the motor. In this case the rated voltage for the coil must be specified, e.g. 230SA. The option is applicable to all motors with brake type FD, FA and BA.*

### M24.2 - BREMSE MIT SEPARATER SPANNUNGSVERSORGUNG

Die Bremsspule wird, unabhängig vom Motor, durch einen separaten Anschluss gespeist. In diesem Fall muss Betriebsspannung fuer die spule spezifiziert werden, z.b. 230SA. Die Option ist verfuegbar für alle Motoren mit Bremstyp FD, FA und BA.

### M24.2 - ALIMENTATION FREIN SEPARÉE

*La bobine du frein est alimentée par une ligne séparée et indépendante de l'alimentation du moteur. La valeur de tension à la bobine doit être spécifiée, ex. 230SA. L'option est applicable aux moteurs avec frein type FD, FA et BA.*

#### ...SD

La bobina del freno tipo FD è alimentata direttamente con corrente continua e l'alimentatore NON è fornito. Il valore di tensione alla bobina deve essere specificato, es. 24SD.

*The brake coil is directly fed with DC current and the rectifier is out of the scope for supply. The rated voltage for the coil must be specified, e.g. 24SD.*

Die Bremsspule wird direkt mit Gleichspannung gespeist. Der Gleichrichter ist nicht im Lieferumfang enthalten. Die Betriebsspannung für die Spule muss spezifiziert werden, z.b. 24SD.

*La bobine du frein type FD est alimentée directement avec courant continu et l'alimentateur n'est pas fourni. La valeur de tension à la bobine doit être spécifiée, es. 24SD.*

### M24.3 - FREQUENZA MASSIMA D'AVVIAMENTO

Nelle tabelle dei dati tecnici, per ogni tipo di freno, è indicata la massima frequenza di inserzione a vuoto  $Z_0$ , con intermittenza  $I = 50\%$ . Questo valore definisce il nume-

### M24.3 - MAXIMUM STARTS PER HOUR

*For all types of Brakes the rating charts reports the maximum number of starts per hour under no-load conditions  $Z_0$  with cyclic duration factor  $I = 50\%$ . This parameter gives the num-*

### M24.3 - MAX. SCHALTHÄUFIGKEIT

In den Tabellen, in denen die technischen Daten enthalten sind, wird für jeden Bremstyp die maximal Schalthäufigkeit im Leerbetrieb  $Z_0$  mit einer Einschaltdauer  $I = 50\%$  angege-

### M24.3 - FREQUENCE MAXIMUM DE DEMARRAGE

*Les tableaux des caractéristiques techniques indiquent, pour chaque type de frein, la fréquence maximum d'enclenchement à vide  $Z_0$ , avec intermittenza  $I = 50\%$ . Cette valeur dé-*

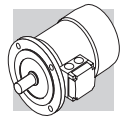

ro di avviamenti orari a vuoto che il motore può sopportare senza superare la temperatura ammessa dalla classe di isolamento F.

Nel caso pratico di motore accoppiato ad un carico esterno con potenza assorbita  $P_r$ , massa inerziale  $J_c$  e coppia resistente media durante l'avviamento  $M_L$ , il numero di avviamenti ammissibile si può calcolare con la seguente formula:

*ber of starts per hour under no-load conditions a motor can withstand without exceeding the temperature limit permitted for insulation class F.*

*Assuming an application involving an overhung load applied to the motor with absorbed power  $P_r$ , inertial mass  $J_c$  and starting mean load torque  $M_L$ , the number of starts allowed is calculated by the following formula:*

ben. Dieser Wert legt die Anzahl der Schaltungen im Leerbetrieb pro Stunde fest, denen der Motor standhalten kann, ohne dabei die von der Isolierstoffklasse F zulässige Temperatur zu überschreiten. Im praktischen Fall eines an eine externe Last gekoppelten Motors mit einer Leistungsaufnahme  $P_r$ , Trägheitsmasse  $J_c$  und einem durchschnittlichen Gegendrehmoment während des Anlaufs  $M_L$ , kann die Anzahl der zulässigen Schaltungen anhand der nachstehenden Formel berechnet werden:

*finis le nombre de démarrages horaires à vide que le moteur peut supporter sans dépasser la température admise par la classe d'isolation F.*

*Dans le cas pratique d'un moteur accouplé à une charge extérieure avec puissance absorbée  $P_r$ , masse inertielle  $J_c$  et couple résistant moyen durant le démarrage  $M_L$ , il est possible de calculer le nombre de démarrages admissibles avec la formule suivante :*

$$Z = \frac{Z_0 \cdot K_c \cdot K_d}{K_J}$$

dove:

$$K_J = \frac{J_m + J_c}{J_m} = \text{fattore di inerzia}$$

$$K_c = \frac{M_a - M_L}{M_a} = \text{fattore di coppia}$$

$K_d$  = fattore di carico vedi tabella:

where

$$K_J = \frac{J_m + J_c}{J_m} = \text{inertia factor}$$

$$K_c = \frac{M_a - M_L}{M_a} = \text{torque factor}$$

$K_d$  = load factor see table:

wobei gilt:

$$K_J = \frac{J_m + J_c}{J_m} = \text{Trägheitsfaktor}$$

$$K_c = \frac{M_a - M_L}{M_a} = \text{Drehmomentsfaktor}$$

$K_d$  = Lastfaktor siehe Tabelle:

où

$$K_J = \frac{J_m + J_c}{J_m} = \text{facteur d'inertie}$$

$$K_c = \frac{M_a - M_L}{M_a} = \text{facteur de couple}$$

$K_d$  = facteur de charge voir tableau

(30)

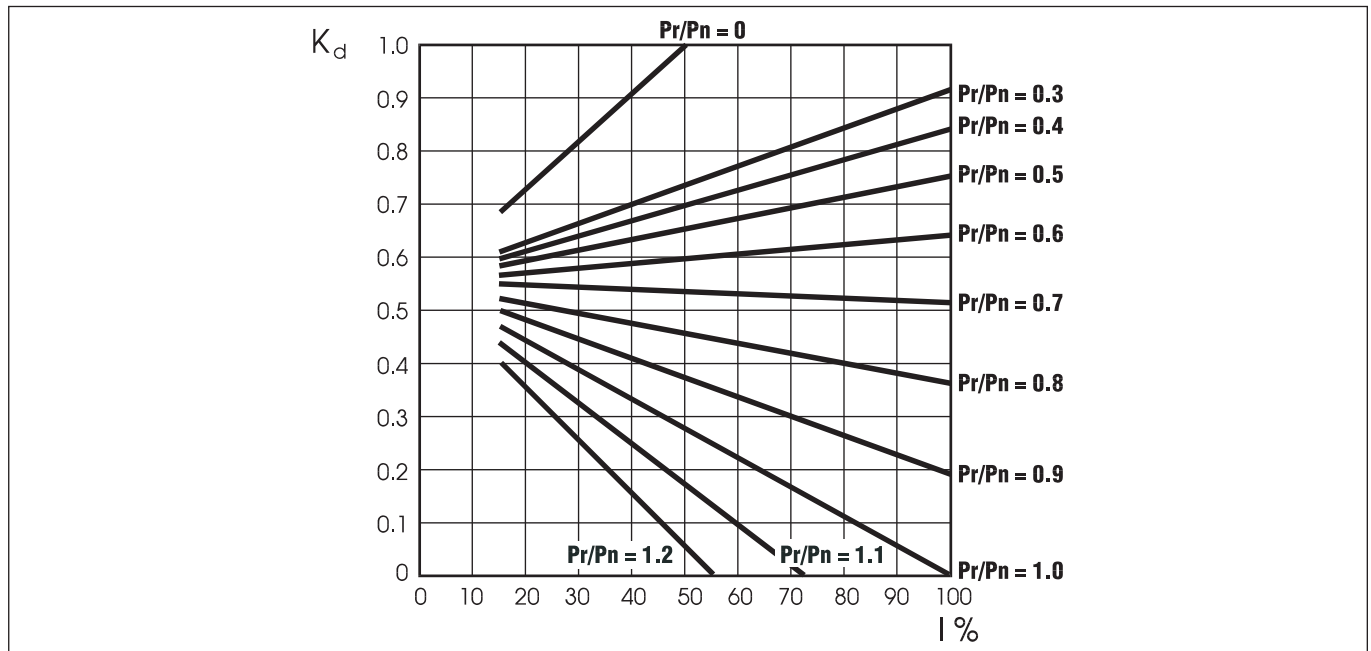

Con il numero di avviamenti così ottenuto si dovrà in seguito verificare che il massimo lavoro di frenatura sia compatibile con la capacità termica del freno  $W_{max}$ .

*The resulting number of starts must be double-checked against maximum braking effort, which must be compatible with brake thermal capacity  $W_{max}$ .*

Auf Grundlage der berechneten Anzahl der Schaltungen muss man prüfen, ob die maximale Bremsleistung mit der angegebenen thermischen Leistung der Bremse  $W_{max}$  übereinstimmt.

*Avec le nombre de démarrages ainsi obtenu, il est ensuite nécessaire de vérifier que l'action maximum de freinage est compatible avec la capacité thermique du frein  $W_{max}$ .*

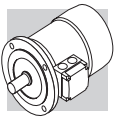

## M24.4 - AVVIAMENTO PROGRESSIVO

## M24.4 - SOFT-START / STOP

## M24.4 - SANFTANLAUF / STOP

## M24.4 - DEMARRAGE/ARRET PROGRESSIF

### F1

Per applicazioni che richiedono progressività nelle fasi di avvio e di arresto è disponibile un volano – opzione **F1** – la cui inerzia aggiuntiva assorbe energia cinetica durante l'avviamento e la restituisce in frenatura, rendendo i transitori più progressivi e gradual.

Il volano è disponibile per i motori autofrenanti del tipo BN\_FD, con caratteristiche specifiche dettagliate nella tabella che segue:

*An optional flywheel – option **F1** – is available for applications requiring soft starting or stopping. The flywheel's added inertia uses up kinetic energy during starting and returns it back during braking, thus catering for more progressive and gradual shock loads.*

*The optional flywheel is available for brake motors type BN\_FD, with specific characteristics as detailed in the table below:*

Für Anwendungen, bei denen einer sanfte Anlauf- und Stop erforderlich ist, steht als – Option **F1** – ein Schwungrad zur Verfügung, dessen zusätzliches Trägheitsmoment während der Anlaufphase kinetische Energie aufnimmt, die in der Abbremsphase wieder abgegeben wird. Dadurch erfolgen die Übergangsphasen progressiver und sanfter. Das Schwungrad ist für die Bremsmotoren vom Typ BN\_FD in den nachstehend aufgeführten spezifischen Details verfügbar:

*Pour les applications nécessitant une progressivité au cours des phases de démarrage et d'arrêt, un volant – option **F1** – est disponible ; son inertie supplémentaire absorbe l'énergie cinétique durant le démarrage et la restitue au moment du freinage, rendant ainsi les phases transitoires plus progressives et graduelles: Le volant est disponible pour les moteurs frein du type BN\_FD, ses caractéristiques spécifiques détaillées sont indiquées dans le tableau suivant :*

(31)

Volano per avviamento progressivo / Flywheel for soft starting / Schwungräder für Sanftanlauf Volant pour démarrage/arrêt progressif		
BN_FD	Peso del volano Flywheel weight Gewicht Schwungrad Poids du volant [Kg]	Inerzia volano Flywheel inertia Trägheitsmoment des Schwungrad Inertie du volant J <sub>v</sub> [Kg m <sup>2</sup> ]
<b>BN 63</b>	0.69	0.00063
<b>BN 71</b>	1.13	0.00135
<b>BN 80</b>	1.67	0.00270
<b>BN 90</b>	2.51	0.00530
<b>BN 100</b>	3.48	0.00840
<b>BN 112</b>	4.82	0.01483
<b>BN 132</b>	6.19	0.02580

Per le esigenze di particolari applicazioni, ad es. traslazioni, che richiedano regolazioni micrometriche della coppia frenante è disponibile una serie di motori autofrenanti, denominata BN\_FM, dettagliata nel catalogo cod. 1134 R1, sviluppato per le motorizzazioni dei carriponte. Consultare per questo il Servizio Tecnico Bonfiglioli.

*For special applications that require a fine adjustment of braking torque, as is the case with track drives, a specific brake motor type BN\_FM is available. This type of product has been developed for bridge crane drives and is described in detail in catalogue no. 1134 R1. Please contact Bonfiglioli Engineering for more details.*

Für besondere Anwendungen, z.B. Transfers, die fein abgestufte Einstellungen des Bremsmoments erfordern, ist eine Reihe an Bremsmotoren verfügbar (BN\_FM) und die detailliert im Katalog Art.-Nr. 1134 R1 beschrieben werden. Dieser Katalog ist für die Antriebe von Laufkränen entwickelt wurde. Wenden Sie sich diesbezüglich bitte an unseren Technischen Kundendienst.

*En cas d'exigences d'applications particulières, par ex. translations, qui nécessitent des réglages micrométriques du couple de freinage, une série de moteurs frein est disponible, dénommée BN\_FM, détaillée dans le catalogue réf. 1134 R1, conçue pour les motorisations des ponts roulants. Dans ce cas, consulter le Service Bonfiglioli.*

## M24.5 - FILTRO CAPACITIVO

## M24.5 - CAPACITIVE FILTER

## M24.5 - KAPAZITIVER FILTER

## M24.5 - FILTRE CAPACITIF

### CF

Per i soli motori autofrenanti in corrente continua, tipo BN\_FD, è disponibile in opzione il filtro capacitivo. Se corredati dell'opportuno filtro capacitivo a monte del raddrizzatore (opzione CF) i motori rientrano nei limiti di emissione previsti dalla Norma EN 50081-1 "Compatibilità elettromagnetica - Norma Generica sull'emissione - Parte 1: Ambienti residenziali, commerciali e dell'industria leggera".

*An optional capacitive filter is available for DC brake motors type BN\_FD only. When the suitable capacitive filter is installed upstream of the rectifier (option CF), motors comply with the emission limits required by standard EN 50081-1 "Electromagnetic Compatibility - Generic Emission Standard - Part 1: Residential, commercial and light industrial environment".*

Nur bei den Bremsmotoren mit Gleichstrombremse vom Typ BN\_FD, ist die Option eines kapazitiven Filters vorgesehen. Wird dieser Filter vor dem Gleichrichter (Option CF) installiert, fallen die Motoren in die von der Norm EN 50081-1 "Elektromagnetische Kompatibilität - Allgemeine Norm zur Emission - Teil 1: Wohngebiete, Handels- und Leichtinduszriezonen" vorgegebenen Emissionsgrenzen.

*Un filtre capacitif en option est disponible uniquement pour les moteurs frein en courant continu type BN\_FD. S'ils sont équipés du filtre capacitif approprié en amont du redresseur (option CF), les moteurs rentrent dans les limites d'émission prévues par la Norme EN 50081-1 "Compatibilité électromagnétique - Norme Générique sur l'émission - Partie 1: Milieux résidentiels, commerciaux et de l'industrie légère".*

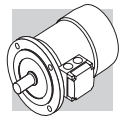

**M25 - MOTORI  
AUTOFRENANTI  
IN C.C., TIPO BN\_FD**

**M25 - DC BRAKE MOTORS  
TYPE BN\_FD**

**M25 - WECHSELSTROMBREMS-  
MOTOREN MIT G.S.-  
BREMSE TYP BN\_FD**

**M25 - MOTEURS FREIN EN  
C.C., TYPE BN\_FD**

- Grandezze: BN 63 ... BN200L

- Frame sizes: BN 63 ... BN200L

- Baugrößen: BN 63 ... BN 200L

- Tailles : BN 63 ... BN200L

(32)

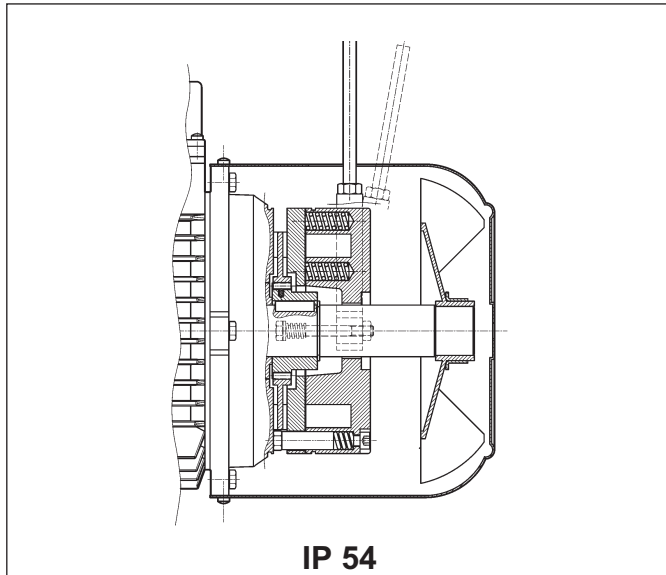

**IP 54**

Freno elettromagnetico con bobina toroidale in corrente continua fissato con viti allo scudo motore; le molle di precarico realizzano il posizionamento assiale del corpo magnete. Il disco freno è scorrevole sul mozzo trascinatore in acciaio calettato sull'albero e previsto di molla antivibrazione. I motori sono forniti con freno tarato in fabbrica al valore di coppia riportato nelle tabelle dati tecnici; la coppia frenante può essere regolata modificando il tipo e/o il numero delle molle. A richiesta, i motori possono essere previsti di leva per lo sblocco manuale con ritorno automatico (R) o con mantenimento della posizione di rilascio freno (RM); per la posizione angolare della leva di sblocco vedi descrizione della relativa variante alla pag. 318. Il freno FD garantisce elevate prestazioni dinamiche e bassa rumorosità; le caratteristiche d'intervento del freno in corrente continua possono essere ottimizzate in funzione dell'applicazione, utilizzando i vari tipi di alimentatore disponibili e/o realizzando l'opportuno cablaggio.

*Direct current toroidal-coil electromagnetic brake bolted onto motor shield. Preloading springs provide axial positioning of magnet body. Brake disc slides axially on steel hub shrunk onto motor shaft with anti-vibration spring. Brake torque factory setting is indicated in the corresponding motor rating charts. Braking torque may be modified by changing the type and/or number of springs. At request, motors may be equipped with manual release lever with automatic return (R) or system for holding brake in the released position (RM). See variant at page 318 for available release lever locations. FD brakes ensure excellent dynamic performance with low noise. DC brake operating characteristics may be optimized to meet application requirements by choosing from the various rectifier/power supply and wiring connection options available.*

(33)

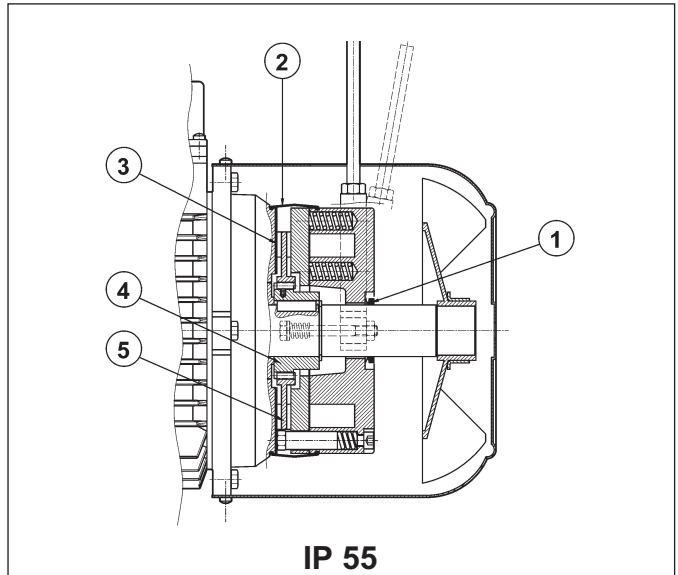

**IP 55**

Elektromagnetische Bremse mit Ringwicklungsspule für Gleichstromspannung, die mittels Schrauben am hinteren Motorschild befestigt ist. Die Federn sorgen für die axiale Ausrichtung des Magnetkörpers. Die Bremscheibe gleitet axial auf der Mitnehmerscheibe aus Stahl, die über eine Paßfeder mit der Motorwelle verbunden und mit einer Schwingungsdämpfung ausgestattet ist. Die Motoren werden vom Hersteller auf den in der Tabelle der technischen Daten angegebenen Bremsmoment eingestellt; das Bremsmoment kann durch das Ändern des Typs und/oder der Anzahl der Federn reguliert werden. Auf Anfrage können die Motoren mit einem Bremslüfthebel für die manuelle Lüftung der Bremse mit selbstständiger Rückstellung (R) ohne Arretierung oder mit arretierbarem Lüfthebel (RM) geliefert werden. Die Festlegung der Position des Bremslüfthebel in Abhängigkeit von der Klemmkastenlage erfolgt durch die Option auf Seite 318. Die Bremse vom Typ FD garantiert hohe dynamische Leistungen und niedrige Laufgeräusche. Die Ansprechigenschaften der Bremse unter Gleichstrom können in Abhängigkeit zur jeweiligen Anwendung durch den Einsatz der verschiedenen verfügbaren Gleichrichter oder durch eine entsprechenden Anschluß der Bremse optimiert werden.

*Frein électromagnétique avec bobine toroïdale en courant continu, fixé avec des vis au bouclier moteur ; les ressorts de précharge réalisent le positionnement axial de la bobine. Le disque frein coulisse de façon axiale sur le moyeu d'entraînement en acier calé sur l'arbre et doté de ressort antivibration. Les moteurs sont fournis avec frein pré réglé en usine à la valeur de couple indiquée dans les tableaux des caractéristiques techniques ; le couple de freinage peut être réglé en modifiant le type et/ou le nombre de ressorts. Sur demande, les moteurs peuvent être équipés de levier pour le déblocage manuel avec retour automatique (R) ou avec maintien de la position de déblocage frein (RM); pour la position angulaire du levier de déblocage, voir description de la variante correspondante à la page 318. Le frein FD garantit des performances dynamiques élevées et un faible niveau de bruit ; les caractéristiques d'intervention du frein en courant continu peuvent être optimisées en fonction de l'application en utilisant les différents types de dispositifs d'alimentation disponibles et/ou en réalisant un câblage approprié.*



### - Grado di protezione

L'esecuzione standard prevede il grado di protezione IP54. In opzione il motore autofrenante tipo FD viene fornito con grado di protezione **IP 55**, prevedendo le seguenti varianti costruttive:

- ① anello V-ring posizionato sull'albero motore N.D.E.
- ② fascia di protezione in gomma
- ③ anello in acciaio inox interposto tra scudo motore e disco freno
- ④ mozzo trascinatore in acciaio inox
- ⑤ disco freno in acciaio inox

### - Degree of protection

Standard protection is IP54. Brake motor FD is also available in protection **IP 55**, which mandates the following variants:

- ① V-ring at N.D.E. of motor shaft
- ② dust and water-proof rubber boot
- ③ stainless steel ring placed between motor shield and brake disc
- ④ stainless steel hub
- ⑤ stainless steel brake disc

### - Schutzart

Die Standardausführung ist Schutzart IP54 vor. Optional kann der Bremsmotor vom Typ FD in der Schutzart **IP 55** geliefert werden, wobei sind folgende Komponenten eingesetzt werden:

- ① V-Ring an der Motorwelle N.D.E.
- ② Schutzring aus Gummi
- ③ Ring aus rostfreiem Stahl zwischen Motorschild und Bremsscheibe
- ④ Mitnehmernabe aus rostfreiem Stahl
- ⑤ Bremsscheibe aus rostfreiem Stahl

### - Degré de protection

L'exécution standard prévoit le degré de protection IP54. En option, le moteur frein type FD est fourni avec degré de protection IP 55, en prévoyant les variantes de construction suivantes :

- ① bague V-ring positionnées sur l'arbre moteur N.D.E.
- ② bande de protection en caoutchouc
- ③ bague en acier inox interposée entre le bouclier moteur et le disque de frein
- ④ moyeu d'entraînement en acier inox
- ⑤ disque frein en acier inox

### - Alimentazione freno FD

L'alimentazione della bobina freno in c.c. è prevista per mezzo di opportuno raddrizzatore montato all'interno della scatola coprimorsetti e già cablato alla bobina del freno. Per motori a singola polarità è inoltre previsto di serie il collegamento del raddrizzatore alla morsettiera motore. Indipendentemente dalla frequenza di rete, la tensione standard di alimentazione del raddrizzatore  $V_B$  ha il valore indicato nella tabella qui di seguito:

### - FD brake power supply

A rectifier accommodated inside the terminal box feeds the DC brake coil. Wiring-connection across rectifier and brake coil is performed at the factory. On all single-pole motors, rectifier is connected to the motor terminal board. Rectifier standard power supply voltage  $V_B$  is as indicated in the following table, regardless of mains frequency:

### - Spannungsversorgung der Bremse FD

Die Versorgung der Gleichstrombremsspule erfolgt über einen Gleichrichter im Klemmenkasten der bei Lieferung, wenn nicht anders bestellt, bereits mit der Bremsspule verkabelt ist. Bei den einpoligen Motoren ist serienmäßig der Anschluss des Gleichrichters an die Motorspannung vorgesehen. Unabhängig von der Netzfrequenz erfolgt die Versorgung des Gleichrichters  $V_B$  über die in der nachstehenden Tabelle angegebenen Standardspannung:

### - Alimentation frein FD

L'alimentation de la bobine de frein en c.c. est prévue au moyen d'un redresseur approprié monté à l'intérieur de la boîte à bornes et déjà câblé à la bobine de frein. De plus, pour les moteurs à simple polarité, le raccordement du redresseur au bornier moteur est prévu de série. Indépendamment de la fréquence du réseau, la tension standard d'alimentation du redresseur  $V_B$  correspond à la valeur indiquée dans le tableau ci-dessous :

(34)

2, 4, 6 P			1 speed
	BN_FD		alimentazione freno da morsettiera brake connected to terminal board power supply Bremsversorgung über die Motorspannung Alimentation frein depuis boîte à bornes
	$V_{mot} \pm 10\%$ 3 ~	$V_B \pm 10\%$ 1 ~	
<b>BN 63...BN 132</b>	230/400 V – 50 Hz	230 V	standard
<b>BN 160...BN 200</b>	400/690 V – 50 Hz	400 V	standard
			alimentazione separata separate power supply Separate Versorgung Alimentation séparée
			specificare $V_B SA$ o $V_B SD$ specify $V_B SA$ or $V_B SD$ $V_B SA$ oder $V_B SD$ angeben spécifier $V_B SA$ ou $V_B SD$
			specificare $V_B SA$ o $V_B SD$ specify $V_B SA$ or $V_B SD$ $V_B SA$ oder $V_B SD$ angeben spécifier $V_B SA$ ou $V_B SD$

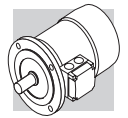

Per i motori a doppia polarità l'alimentazione standard del freno è da linea separata con tensione d'ingresso al raddrizzatore  $V_B$  come indicato in tabella:

*Switch-pole motors feature a separate power supply line for the brake with rectifier input voltage  $V_B$  as indicated in the table:*

Die polumschaltbaren Motoren müssen immer mit separater Bremsversorgungsspannung betrieben werden, deshalb erfolgt die Lieferung standardmäßig ohne Anschluß der Bremse an die Motorspannung, da diese mit einer am Eingang des Gleichrichters  $V_B$  anliegenden Spannung versorgt werden muß, entsprechend Werte in der nachstehenden Tabelle:

*Pour les moteurs à double polarité, l'alimentation standard du frein dérive d'une ligne séparée avec tension d'entrée a redresseur  $V_B$  comme indiqué dans le tableau :*

(35)

2/4, 2/6, 2/8, 2/12, 4/6, 4/8 P			2 speed	
	<b>BN_FD</b>		alimentazione freno da morsettiera <i>brake powered via terminal board</i> Bremsversorgung über die Motorspannung <i>Alimentation frein depuis boîte à bornes</i>	alimentazione separata <i>separate power supply</i> Separate Versorgung <i>Alimentation séparée</i>
	$V_{mot} \pm 10\%$ 3 ~	$V_B \pm 10\%$ 1 ~		
<b>BN 63...BN 132</b>	400 V – 50 Hz	230 V	●	specificare $V_B$ SA o $V_B$ SD <i>specify <math>V_B</math> SA or <math>V_B</math> SD</i> $V_B$ SA oder $V_B$ SD angeben <i>spécifier <math>V_B</math> SA ou <math>V_B</math> SD</i>

Il raddrizzatore è del tipo a diodi a semionda ( $V_{c.c} \approx 0,45 \times V_{c.a.}$ ) ed è disponibile nelle versioni **NB, SB, NBR** e **SBR, SBR**, come dettagliato nella tabella seguente:

*The diode half-wave rectifier (VDC  $\approx 0,45 \times VAC$ ) is available in versions **NB, SB, NBR** e **SBR, SBR**, as detailed in the table below:*

Bei dem Gleichrichter handelt es sich um einen Typ mit Halbwelldioden ( $V_{c.c} \approx 0,45 \times V_{c.a.}$ ). Er ist in den Versionen **NB, SB, NBR** und **SBR**, gemäß den Details in der nachstehenden Tabelle, verfügbar:

*Le redresseur est du type à diodes à demi-onde ( $V_{c.c} \approx 0,45 \times V_{c.a.}$ ) et il est disponible dans les versions **NB, SB, NBR** et **SBR, SBR**, comme indiqué de façon détaillée dans le tableau suivant :*

(36)

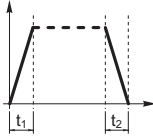
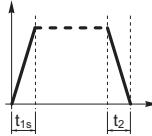
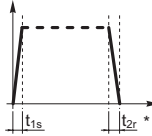
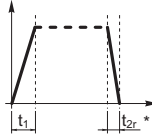
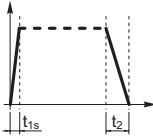
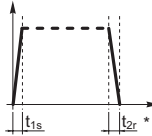
	Freno Brake Bremse Ffrein	Raddrizzatore / Rectifier Gleichrichter / Redresseur	
		standard	A richiesta / At request Auf Anfrage / Sur demande
<b>BN 63</b>	FD 02	<b>NB</b> 	
<b>BN 71</b>	FD 03		<b>SB</b> 
	FD 53		
<b>BN 80</b>	FD 04		<b>SBR</b> 
<b>BN 90S</b>	FD 14		
<b>BN 90L</b>	FD 05		
<b>BN 100</b>	FD 15		
<b>BN 112</b>	FD 06S	<b>SB</b> 	<b>SBR</b> 
<b>BN 132 - 160MR</b>	FD 56		
	FD 06		
	FD 07		
<b>BN 160L - BN 180M</b>	FD 08		
<b>BN 180L - BN 200M</b>	FD 09		

(\*)  $t_{2c} < t_{2r} < t_2$



I raddrizzatore **SB** a controllo elettronico dell'eccitazione, riduce i tempi di sblocco del freno sovraccitando l'elettromagnete nei primi istanti d'inserzione, per passare poi al normale funzionamento a semionda a distacco del freno avvenuto.

L'impiego del raddrizzatore tipo **SB** è sempre da prevedere nei casi di:

- elevato numero di interventi orari
- tempi di sblocco freno ridotti
- elevate sollecitazioni termiche del freno.

Per applicazioni dove è richiesto un rapido rilascio del freno sono disponibili a richiesta i raddrizzatori **NBR** o **SBR**.

Questi raddrizzatori completano i tipi **NB** e **SB**, integrando nel circuito elettronico un interruttore statico che interviene diseccitando rapidamente il freno in caso di mancanza di tensione.

Questa soluzione consente di ridurre i tempi di rilascio del freno evitando ulteriori cablaggi e contatti esterni.

Per il migliore utilizzo dei raddrizzatori **NBR** e **SBR** è richiesta l'alimentazione separata del freno.

Tensioni disponibili: 230V  $\pm$  10%, 400V  $\pm$  10%, 50/60 Hz.

*Rectifier **SB** with electronic energizing control over-energizes the electromagnet upon power-up to cut brake release response time and then switches to normal half-wave operation once the brake has been released.*

*Use of the **SB** rectifier is mandatory in the event of:*

- *high number of operations per hour*
- *reduced brake release response time*
- *brake is exposed to extreme thermal stress.*

*Rectifiers **NBR** or **SBR** are available for applications requiring quick brake release response.*

*These rectifiers complement the **NB** and **SB** types as their electronic circuit incorporates a static switch that de-energizes the brake quickly in the event voltage is missing.*

*This arrangement ensures short brake release response time with no need for additional external wiring and contacts.*

*Optimum performance of rectifiers **NBR** and **SBR** is achieved with separate brake power supply.*

*Available voltages: 230V  $\pm$  10%, 400V  $\pm$  10%, 50/60 Hz.*

Der Gleichrichter **SB** mit elektronischer Kontrolle der Erregung reduziert die Bremslösezeiten, indem er die Bremsspannung in den ersten Momenten der Einschaltung übermäßig erregt, um dann, nach erfolgter Bremslösung, in die normale Halbwellenfunktion umzuschalten.

Der Einsatz eines Gleichrichters vom Typ **SB** wird in folgenden Fällen empfohlen:

- hohe Anzahl von Schaltungen pro Stunde
- schnelle Bremsansprechzeiten
- starke thermische Beanspruchungen der Bremse.

Für die Anwendungen, bei denen eine schnelle Ansprechzeit der Bremse gefordert wird, können auf Anfrage die Gleichrichter **NBR** oder **SBR** geliefert werden. Diese Gleichrichter erweitern die Funktion der Typen **NB** und **SB**, indem in dem elektronischen Schaltkreis ein statischer Schalter integriert ist, durch dessen Auslösen die Bremse im Fall eines Spannungsausfalls schnell abgeregt wird. Diese Lösung ermöglicht eine Verringerung der Ansprechzeiten der Bremse, wodurch weitere Schaltungen und externe Sensoren vermieden werden können. Im Hinblick auf einen besseren Einsatz der Gleichrichter **NBR** und **SBR** ist bei der Bremse eine separate Versorgung erforderlich. Verfügbare Spannungen: 230V  $\pm$  10%, 400V  $\pm$  10%, 50/60 Hz.

*Le redresseur **SB** à contrôle électronique de l'excitation réduit les temps de déblocage du frein en surexcitant l'électro-aimant durant les premiers instants d'enclenchement pour passer ensuite au fonctionnement normal à demi-onde une fois le frein désactivé.*

*L'utilisation du redresseur type **SB** doit toujours être prévue dans les cas suivants:*

- *nombre d'interventions horaires élevé*
- *temps de déblocage frein réduits*
- *sollicitations thermiques du frein élevées.*

*Pour les applications nécessitant un déblocage rapide du frein, sur demande les redresseurs **NBR** ou **SBR** sont disponibles.*

*Ces redresseurs complètent les types **NB** et **SB**, en intégrant dans le circuit électronique un interrupteur statique qui intervient en désexcitant rapidement le frein en cas de coupure de tension.*

*Cette solution permet de réduire les temps de déblocage du frein en évitant d'autres câblages et contacts extérieurs.*

*Pour une meilleure utilisation des redresseurs **NBR** et **SBR** l'alimentation séparée du frein est nécessaire.*

*Tensions disponibles : 230V  $\pm$  10%, 400V  $\pm$  10%, 50/60 Hz.*

#### - Dati tecnici freni FD

Nella tabella sottostante sono riportati i dati tecnici dei freni in c.c. tipo FD.

#### - *FD brake technical specifications*

*The table below reports the technical specifications of DC brakes FD.*

#### - Technische Daten - Bremstyp FD

In der nachstehenden Tabelle werden die technischen Daten der Gleichstrombremsen vom Typ FD angegeben.

#### - *Caractéristiques techniques freins FD*

*Le tableau suivant indique les caractéristiques techniques des freins en c.c. type FD.*





(37)

Freno Brake Bremse Frein	Coppia frenante $M_b$ Brake torque $M_b$ Bremsmoment $M_b$ Couple de freinage $M_b$ [Nm]			Rilascio Release Anspruchzeit Déblocage		Frenatura Braking Bremszeit Freinage		Wmax per frenata Wmax per brake operation Wmax pro Bremsung Wmax par freinage			W	P
	n° molle / no. of springs Feder / ressorts			$t_1$ [ms]	$t_{1s}$ [ms]	$t_2$ [ms]	$t_{2c}$ [ms]	[J]				
	6	4	2					10 c/h	100 c/h	1000 c/h	[MJ]	[W]
<b>FD 02</b>	—	3.5	1.75	30	15	80	9	4500	1400	180	15	17
<b>FD 03</b>	5	3.5	1.75	50	20	100	12	7000	1900	230	25	24
<b>FD 53</b>	7.5	5	2.5	60	30	100	12					
<b>FD 04</b>	15	10	5	80	35	140	15	10000	3100	350	30	33
<b>FD 14</b>												
<b>FD 05</b>	40	26	13	150	65	170	20	18000	4500	500	50	45
<b>FD 15</b>	40	26	13	150	65	170	20					
<b>FD 55</b>	55	37	18	—	65	170	20	20000	4800	550	70	55
<b>FD 06S</b>	60	40	20	—	80	220	25					
<b>FD 56</b>	—	75	37	—	90	150	20	29000	7400	800	80	65
<b>FD 06</b>	—	100	50	—	100	150	20					
<b>FD 07</b>	150	100	50	—	120	200	25	40000	9300	1000	130	65
<b>FD 08 *</b>	250	200	170	—	140	350	30	60000	14000	1500	230	100
<b>FD 09 **</b>	400	300	200	—	200	450	40	70000	15000	1700	230	120

\* valori di coppia frenante ottenuti con n° 9,7,6 molle rispettivamente

\* brake torque values obtained with 9, 7 and 6 springs, respectively

\* Werte, der durch den Einsatz von jeweils 9, 7, 6 Federn erreichten Bremsmomente

\* valeurs de couple de freinage obtenues respectivement avec n° 9, 7, 6 ressorts

\*\* valori di coppia frenante ottenuti con n° 12,9,6 molle rispettivamente

\*\* brake torque values obtained with 12, 9 and 6 springs, respectively

\*\* Werte, der durch den Einsatz von jeweils 12, 9, 6 Federn erreichten Bremsmomente

\*\* valeurs de couple de freinage obtenues respectivement avec n° 12, 9, 6 ressorts

**Legenda:**

$t_1$  = tempo di rilascio del freno con alimentatore a semionda  
 $t_{1s}$  = tempo di rilascio del freno con alimentatore con sovraeccitazione.  
 $t_2$  = ritardo di frenatura con interruzione lato c.a. e alimentazione separata  
 $t_{2c}$  = ritardo di frenatura con interruzione lato c.a. e c.c. I valori di  $t_1$ ,  $t_{1s}$ ,  $t_2$ ,  $t_{2c}$ , indicati nella tabella (37) sono riferiti al freno tarato alla coppia massima, traferro medio e tensione nominale.  
 $W_{max}$  = energia max per frenata  
 $W$  = energia di frenatura tra due regolazioni successive  
 $P_b$  = potenza assorbita dal freno a 20°C  
 $M_b$  = coppia frenante statica ( $\pm 15\%$ )  
 $c/h$  = avviamenti orari

**Key:**

$t_1$  = brake release time with half-wave rectifier  
 $t_{1s}$  = brake release time with over-energizing rectifier  
 $t_2$  = brake engagement time with AC line interruption and separate power supply  
 $t_{2c}$  = brake engagement time with AC and DC line interruption – Values for  $t_1$ ,  $t_{1s}$ ,  $t_2$ ,  $t_{2c}$  indicated in the tab. (37) are referred to brake set at maximum torque, medium air gap and rated voltage  
 $W_{max}$  = max energy per brake operation  
 $W$  = braking energy between two successive air gap adjustments  
 $P_b$  = brake power absorption at 20 °C  
 $M_b$  = static braking torque ( $\pm 15\%$ )  
 $c/h$  = starts per hour

**Legende:**

$t_1$  = Ansprechzeit der Bremse mit Halbwellengleichrichter  
 $t_{1s}$  = Ansprechzeit der Bremse mit elektronisch gesteuerten Erregungsgleichrichter  
 $t_2$  = Bremsverzögerung mit Unterbrechung auf Wechselstromseite und Fremdversorgung  
 $t_{2c}$  = Bremsverzögerung mit Unterbrechung auf Wechselstrom- und Gleichstromseite – Die in der Tab. (37) angegebenen Werte  $t_1$ ,  $t_{1s}$ ,  $t_2$ ,  $t_{2c}$ , beziehen sich auf eine auf das max. Bremsmoment geeichte Bremse, mit mittlerem Luftspalt und Nennspannung.  
 $W_{max}$  = max. Energie pro Bremsung  
 $W$  = Bremsenergie zwischen zwei Einstellungen des Luftspalts  
 $P_b$  = bei 20° C von der Bremse aufgenommene Leistung (50 Hz)  
 $M_b$  = statisches Bremsmoment ( $\pm 15\%$ )  
 $c/h$  = Schaltungen pro stunde

**Légende:**

$t_1$  = temps de déblocage du frein avec dispositif d'alimentation à demi-onde  
 $t_{1s}$  = temps de déblocage du frein avec dispositif d'alimentation à contrôle électronique de l'excitation  
 $t_2$  = retard de freinage avec interruption côté c.a. et alimentation séparée  
 $t_{2c}$  = retard de freinage avec interruption côté c.c. Les valeurs de  $t_1$ ,  $t_{1s}$ ,  $t_2$ ,  $t_{2c}$ , indiquées dans le tab. (37) se réfèrent au frein étalonné au couple maximal, entrefer moyen et tension nominale.  
 $W_{max}$  = énergie max. par freinage  
 $W$  = énergie de freinage entre deux réglages successifs de l'entrefer  
 $P_b$  = puissance absorbée par le frein à 20 °C  
 $M_b$  = couple de freinage statique ( $\pm 15\%$ )  
 $c/h$  = démarrages horaires

**- Collegamenti freno FD**

I motori standard ad una velocità sono forniti con il collegamento del raddrizzatore alla morsettiera motore già realizzata in fabbrica.  
 Per motori a 2 velocità, e dove è richiesta l'alimentazione del freno separata, prevedere il collegamento al raddrizzatore in ac-

**- FD brake connections**

On standard single-pole motors, the rectifier is connected to the motor terminal board at the factory.  
 For switch-pole motors and where a separate brake power supply is required, connection to rectifier must comply with brake voltage  $V_B$  stated in mo-

**- Anschlüsse - Bremstyp FD**

Die einpoligen Motoren werden vom Werk ab mit an die Motorspannung angeschlossenem Gleichrichters geliefert. Für die polumschaltbaren Motoren, und Bremse mit separater Versorgung, wird in Übereinstimmung mit der auf dem Typenschild des Motors angegebenen Brems-

**- Raccordements frein FD**

Les moteurs standard à une vitesse sont fournis avec le raccordement du redresseur au bornier moteur déjà réalisé en usine.  
 Pour les moteurs à 2 vitesses, et lorsqu'une alimentation séparée du frein est requise, prévoir le raccordement au redresseur conformément à la tension

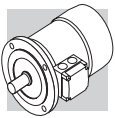

cordo alla tensione freno  $V_B$  indicata nella targhetta del motore.

Data la natura induttiva del carico, per il comando del freno e per l'interruzione lato corrente continua devono essere utilizzati contatti con categoria d'impiego AC-3 secondo IEC 60947-4-1.

tor name plate.

Because the load is of the inductive type, brake control and DC line interruption must use contacts from the usage class AC-3 to IEC 60947-4-1.

spannung  $V_B$  der Anschluss an den Gleichrichter vorgesehen.

Da es sich bei der Bremsleistung um eine induktive Kraft handelt, müssen gemäß IEC 60947-4-1 für die Steuerung der Bremse und die Unterbrechung der Gleichstromseite Kontakte der Kategorie AC-3 verwendet werden.

frein  $V_B$  indiquée sur la plaque signalétique du moteur.

Etant donné la nature inductive de la charge, pour la commande du frein et l'interruption côté courant continu, il est nécessaire d'utiliser des contacts avec catégorie d'utilisation AC-3 selon la norme IEC 60947-4-1.

Tabella (38) - Alimentazione freno dai morsetti motore ed interruzione lato a.c.

Tempo di arresto  $t_2$  ritardato e funzione delle costanti di tempo del motore.

Da prevedere quando sono richiesti avviamenti/arresti progressivi.

Tabella (39) - Bobina freno con alimentazione separata ed interruzione lato c.a.

Tempo di arresto normale ed indipendente dal motore.

Tabella (40) - Bobina freno con alimentazione dai morsetti motore ed interruzione lato c.a. e c.c.

Arresto rapido con i tempi d'intervento  $t_{2c}$ .

Tabella (41) - Bobina freno con alimentazione separata ed interruzione lato c.a. e c.c.

Tempo di arresto ridotto secondo i valori  $t_{2c}$ .

Table (38) - Brake power supply from motor terminals and AC line interruption.

Delayed stop time  $t_2$  and function of motor time constants.

Mandatory when soft-start/stops are required.

Table (39) - Brake coil with separate power supply and AC line interruption

Normal stop time independent of motor.

Table (40) - Brake coil power supply from motor terminals and AC/DC line interruption.

Quick stop with operation times  $t_{2c}$ .

Table (41) - Brake coil with separate power supply and AC/DC line interruption.

Stop time decreases by values  $t_{2c}$ .

Tabelle (38) - Bremsversorgung über die Motorspannung und Unterbrechung der Wechselstromseite. Verzögerter und von den Zeitkonstanten des Motors abhängige Haltezeit  $t_2$ . Vorzusehen, wenn progressive Starts/Stopp erforderlich sind.

Tabelle (39) - Bremsspule mit separater Spannungsversorgung und Unterbrechung der Wechselstromseite. Normale und vom Motor unabhängige Stoppzeiten.

Tabelle (40) - Bremsspule mit Versorgung über die Motorspannung und Unterbrechung der Gleich- und der Wechselstromseite. Schneller Stopp mit angegebenen Ansprechzeiten  $t_{2c}$ .

Tabelle (41) - Bremsspule mit separater Spannungsversorgung und Unterbrechung der Gleich- und der Wechselstromseite. Reduzierte Stoppzeiten angegebenen Werte  $t_{2c}$ .

Tableau (38) - Alimentation frein depuis bornes moteur et interruption côté c.a.

Temps d'arrêt  $t_2$  retardé et fonction des constantes de temps du moteur.

A prévoir lorsque des démarrages/arrests progressifs sont requis.

Tableau (39) - Bobine de frein avec alimentation séparée et interrupteur côté c.a.

Temps d'arrêt normal et indépendant du moteur.

Tableau (40) - Bobine de frein avec alimentation depuis les bornes moteur et interruption côté c.a. et c.c.

Arrêt rapide avec les temps d'intervention  $t_{2c}$ .

Tableau (41) - Bobine de frein avec alimentation séparée et interruption côté c.a. et c.c.

Temps d'arrêt réduit selon les valeurs  $t_{2c}$ .

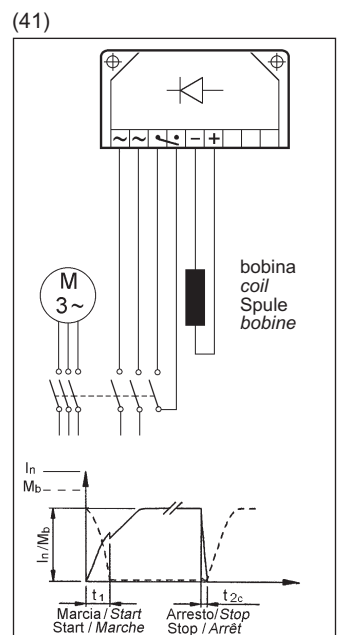
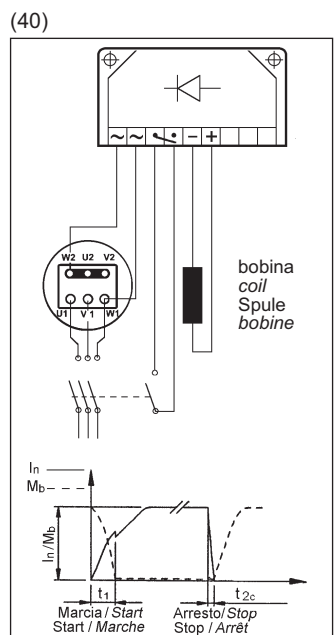
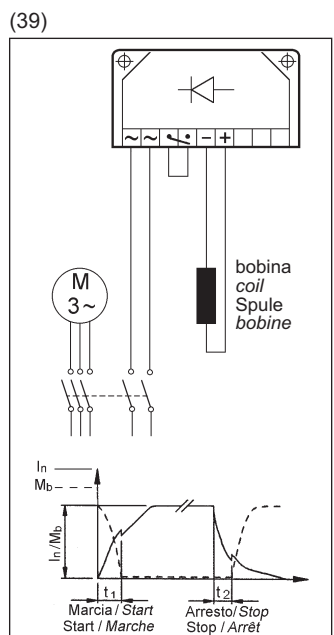
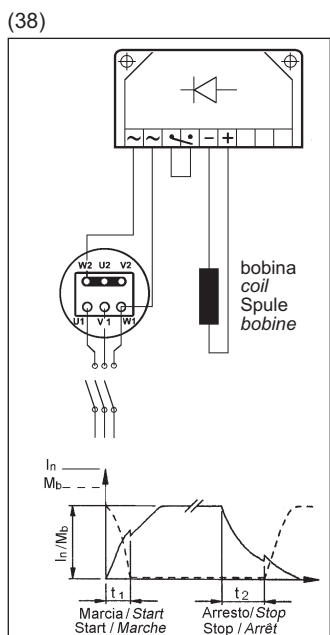

Le tabelle da (38) a (41) riportano gli schemi tipici di collegamento per alimentazione 400 V, motori 230/400V collegati a stella e freno 230 V.

Tables (38) through (41) show the typical connection diagrams for 400 V power supply, star-connected 230/400V motors and 230 V brake.

In den Tabellen (38) bis (41) werden die typischen Schaltungen für Versorgung mit 400 V, Motoren 230/400V mit Sternschaltung und einer Bremsspannung von 230 V wiedergegeben.

Les tableaux de (38) à (41) indiquent les schémas typiques de branchement pour une alimentation de 400 V, moteurs 230/400V raccordés en étoile et frein 230 V.



**M26 - MOTORI AUTOFRENANTI  
IN C.A. TIPO BN\_FA**

**M26 - AC BRAKE MOTORS  
TYPE BN\_FA**

**M26 - WECHSELSTROMBREMS-  
MOTOREN MIT W.S.-  
BREMSE TYP BN\_FA**

**M26 - MOTEURS FREIN  
EN C.A. TYPE BN\_FA**

- **Grandezze:** BN 63 ... BN 180M

- **Frame sizes:** BN 63 ... BN 180M

- **Baugrößen:** BN 63 ... BN 180M

- **Tailles:** BN 63 ... BN 180M

(42)

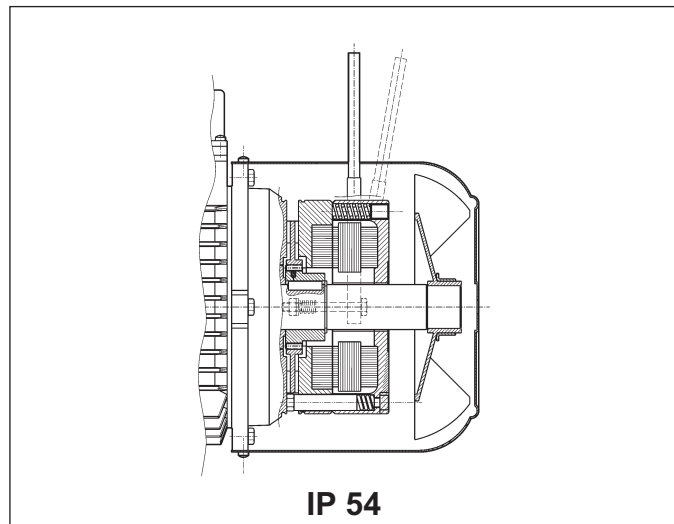

**IP 54**

(43)

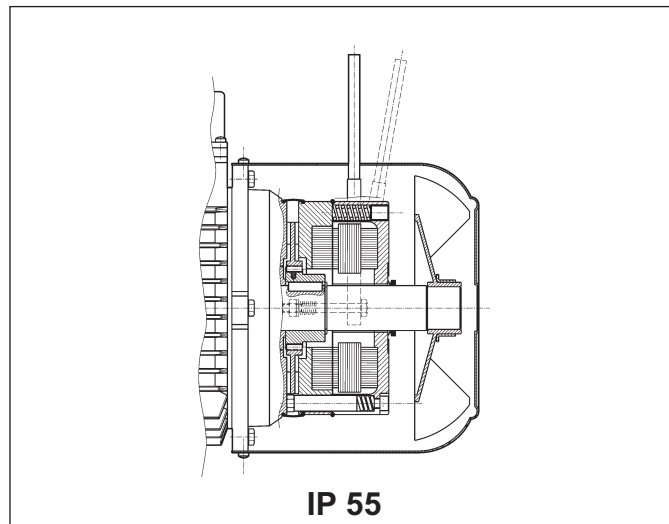

**IP 55**

Freno elettromagnetico con alimentazione in **corrente alternata** trifase, fissato con viti allo scudo motore; le molle di precarico realizzano il posizionamento assiale del corpo magnete.

Il disco freno è scorrevole assialmente sul mozzo trascinatore in acciaio calettato sull'albero e previsto di molla antivibrazione. La coppia frenante è preimpostata in fabbrica su valori che sono indicati nelle tabelle dati tecnici dei relativi motori.

L'azione del freno è inoltre modulabile, regolando con continuità la coppia frenante, tramite le viti che realizzano il precarico delle molle; il campo di regolazione della coppia è:  $30\% M_{bMAX} < M_b < M_{bMAX}$  ( $M_{bMAX}$  è il momento frenante max riportato in tab. (46).

Il freno tipo FA presenta dinamiche molto elevate che lo rendono idoneo in applicazioni dove sono richieste frequenze di avviamento elevate con tempi d'intervento molto rapidi.

A richiesta, i motori possono essere previsti di leva per lo sblocco manuale con ritorno automatico (R). Per la specifica della posizione angolare della leva vedi relativa variante alla pag. 318.

*Electromagnetic brake operates from three-phase **alternated current** power supply and is bolted onto conveyor shield. Preloading springs provide axial positioning of magnet body.*

*Steel brake disc slides axially on steel hub shrunk onto motor shaft with anti-vibration spring. Brake torque factory setting is indicated in the corresponding motor rating charts.*

*Spring preloading screws provide stepless braking torque adjustment. Torque adjustment range is  $30\% M_{bMAX} < M_b < M_{bMAX}$  (where  $M_{bMAX}$  is maximum braking torque as shown in tab. (46).*

*Thanks to their high dynamic characteristics, FA brakes are ideal for heavy-duty applications as well as applications requiring frequent stop/starts and very fast response time.*

*Motors may be equipped with manual release lever with automatic return (R) at request. See variants at page 318 for available lever locations.*

Elektromagnetische Bremse mit **Drehstromversorgung**, die mittels Schrauben am hinteren Motorschild befestigt ist. Die Federn sorgen dabei für die axiale Ausrichtung des Magnetkörpers. Die Bremsscheibe (Stahl) gleitet axial auf dem sich auf dem Rotor befindlichen Mitnehmer, der über eine Paßfeder mit Motorwelle verbunden und mit einer Schwingungsdämpffeder ausgestattet ist. as Bremsmoment wird auf das entsprechende Motor-

moment eingestellt (siehe Tabelle der technischen Daten der entsprechenden Motoren). Das Bremsmoment ist stufenlos durch über die Schrauben die die Federvorspannung einstellbar. Der Einstellbereich beträgt  $30\% M_{bMAX} < M_b < M_{bMAX}$  ( $M_{bMAX}$  steht für den max. Bremsmoment, der in der Tab (46) angegeben wird). Die Bremse vom Typ FA zeichnet sich durch ihre hohen Dynamik aus, weshalb sie für Anwendungen geeignet sind, in denen hohe Schaltfrequenzen und schnelle Ansprechzeiten gefordert werden. Auf Anfrage können die Motoren mit einem Lüfterhebel für die manuelle Lüftung der Bremse mit automatischer Rückstellung (R) geliefert werden. Die Angabe der Montageposition erfolgt über die Angabe der Option auf Seite 318.

*Frein électromagnétique avec alimentation en **courant alternatif** triphasé, fixé avec des vis au bouclier ; les ressorts de précharge réalisent le positionnement axial de la bobine.*

*Le disque frein coulisse de façon axiale sur le moyeu d'entraînement en acier, calé sur l'arbre et doté de ressort antivibration.*

*Le couple de freinage est pré réglé en usine aux valeurs qui sont indiquées dans les tableaux des caractéristiques techniques des moteurs correspondants. De plus, l'action du frein est modulable, en réglant le couple de freinage en continu au moyen des vis qui réalisent la précharge des ressorts ; la plage de réglage du couple est de  $30\% M_{bMAX} < M_b < M_{bMAX}$  ( $M_{bMAX}$  est le couple de freinage maximum indiqué dans le tab. (46).*

*Le frein type FA présente des caractéristiques dynamiques très élevées, il est donc adapté pour des applications nécessitant des fréquences de démarrage élevées et des temps d'intervention très rapides.*

*Sur demande, les moteurs peuvent être prévus avec levier pour le déblocage manuel avec retour automatique (R). Pour la spécification de la position angulaire du levier, voir variante page 318.*



**- Grado di protezione**

L'esecuzione standard prevede il grado di protezione IP54.

In opzione, il motore autofrenante BN\_FA viene fornito con grado di protezione **IP 55** prevedendo le seguenti varianti costruttive:

- anello V-ring posizionato sull'albero motore N.D.E.
- fascia di protezione in gomma
- anello o-ring

**- Degree of protection**

Standard protection is IP54.

Brake motor BN\_FA is also available in protection **IP 55**, which mandates the following variants:

- V-ring at N.D.E. of motor shaft
- rubber boot
- O-ring

**- Schutzart**

Die Standardausführung ist Schutzart IP54 vor.

Optional kann der Bremsmotor BN\_FA auch in der Schutzart IP 55 geliefert werden, was durch die folgenden zusätzlichen Bauteile erreicht wird:

- V-Ring an der Motorwelle N.D.E.
- Schutzring aus Gummi
- O-Ring

**- Degré de protection**

L'exécution standard prévoit le degré de protection IP54.

En option, le moteur frein BN\_FA est fourni avec degré de protection **IP 55**, les variations de construction suivantes sont prévues :

- bague V-ring positionné sur l'arbre moteur N.D.E.
- bande de protection en caoutchouc
- joint torique

**- Alimentazione freno FA**

Nei motori a singola polarità l'alimentazione della bobina freno è derivata direttamente dalla morsettiera motore e la tensione del freno quindi coincide con la tensione del motore. In questo caso la tensione del freno può essere omessa dalla designazione.

Per i motori a doppia polarità, e per i motori con alimentazione separata del freno, è presente una morsettiera ausiliaria con 6 terminali per il collegamento alla linea del freno. In entrambi i casi il valore di tensione del freno dovrà essere specificato in designazione.

Nella tabella seguente sono riportate le condizioni di alimentazione standard del freno in c.a. per i motori a singola e doppia polarità:

**- FA brake power supply**

In single-pole motors, power supply is brought to the brake coil direct from the motor terminal box. As a result, brake voltage and motor voltage are the same. In this case, brake voltage indication may be omitted in the designation.

Switch-pole motors and motors with separate brake power supply feature an auxiliary terminal board with 6 terminals for connection to brake line. In both cases, brake voltage indication in the designation is mandatory. The following table reports standard AC brake power supply ratings for single- and switch-pole motors:

**- Stromversorgung - Bremstyp FA**

Bei den einpoligen Motoren wird die Versorgung der Bremsspule direkt vom Motorklemmenkasten abgenommen, das bedeutet, dass die Spannung der Bremse mit der Motorspannung übereinstimmt. In diesem Fall braucht die Bremsenspannung nicht extra angegeben werden.

Für die polumschaltbaren Motoren und für eine separate Bremsversorgung ist eine Hilfsklemmenleiste mit 6 Anschlüssen vorgesehen, die einen Anschluß der Bremse ermöglichen. In beiden Fällen muss die Bremsspannung in der Bestellung angegeben werden.

In der nachstehenden Tabelle werden für die einpoligen und die polumschaltbaren Motoren die Standardspannungen der Wechselstrombremsen angegeben:

**- Alimentation frein FA**

Sur les moteurs à simple polarité, l'alimentation de la bobine frein dérive directement du bornier moteur, par conséquent, la tension du frein coïncide avec la tension du moteur. Dans ce cas, la tension du frein peut être omise de la désignation.

Pour les moteurs à double polarité et les moteurs avec alimentation séparée du frein, une boîte à bornes auxiliaire avec 6 bornes pour le raccordement à la ligne du frein, est présente. Dans les deux cas, la valeur de tension du frein doit être spécifiée dans la désignation. Le tableau suivant indique les conditions d'alimentation standard du frein en c.a. pour les moteurs à simple et double polarité :

(44)

<b>Motori a singola polarità</b> <b>Single-speed motors</b> <b>Einpolige Motoren</b> <b>Moteurs à simple polarité</b>	<b>BN 63 ... BN 132</b>	<b>BN 160 ... BN 180 M</b>
	230Δ / 400Y V ±10% – 50 Hz	400Δ / 690Y V ±10% – 50 Hz
	265Δ / 460Y V ±10% - 60 Hz	460Δ V – 60 Hz

(45)

<b>Motori a doppia polarità</b> (alimentazione da linea separata) <b>Switch-speed motors</b> (separate power supply line) <b>Polumschaltbare Motoren</b> (separate Versorgung) <b>Moteurs à double polarité</b> (alimentation depuis ligne séparée)	<b>BN 63 ... BN 132</b>
	230Δ / 400Y V ±10% – 50 Hz
	460Y V – 60 Hz

Su richiesta, sono disponibili tensioni speciali, nel campo 24...690 V, 50... 60 Hz.

Special voltages in the 24...690 V, 50... 60 Hz range are available at request.

Auf Anfrage können Sonderspannungen von 24...690 V, 50... 60 Hz geliefert werden.

Sur demande, des tensions spéciales sont disponibles dans la plage 24...690 V, 50... 60 Hz.

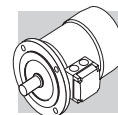

- Dati tecnici freni FA

- FA brake technical specifications

- Technische Daten der Bremsen vom Typ FA

- Caractéristiques techniques freins FA

(46)

	Freno Brake Bremse Frein	Coppia frenante $M_b$ Brake torque $M_b$ Bremsmoment $M_b$ Couple de freinage $M_b$	Rilascio Release Ansprchzeit Déblocage	Frenatura Braking Bremszeit Freinage	W max			W	P <sub>b</sub>
					[J]				
		[Nm]	t <sub>1</sub> [ms]	t <sub>2</sub> [ms]	10 c/h	100 c/h	1000 c/h	[MJ]	[VA]
	<b>FA 02</b>	3.5	4	20	4500	1400	180	15	60
	<b>FA 03</b>	7.5	4	40	7000	1900	230	25	80
	<b>FA 04</b>	15	6	60	10000	3100	350	30	110
	<b>FA 14</b>								
	<b>FA 05</b>	40	8	90	18000	4500	500	50	250
	<b>FA 15</b>								
	<b>FA 06S</b>	60	16	120	20000	4800	550	70	470
	<b>FA 06</b>	75	16	140	29000	7400	800	80	550
	<b>FA 07</b>	150	16	180	40000	9300	1000	130	600
	<b>FA 08</b>	250	20	200	60000	14000	1500	230	1200

Legenda:

$M_b$  = max coppia frenante statica (± 15%)  
 $t_1$  = tempo di rilascio del freno  
 $t_2$  = ritardo di frenatura  
 $W_{max}$  = energia max per frenata (capacità termica del freno)  
 $W$  = energia di frenatura tra due regolazioni successive del traferro  
 $P_b$  = potenza assorbita dal freno a 20°C (50 Hz)  
 c/h = avviamenti orari

Key:

$M_b$  = max static braking torque (15%)  
 $t_1$  = brake release time  
 $t_2$  = brake engagement time  
 $W_{max}$  = max energy per brake operation (brake thermal capacity)  
 $W$  = braking energy between two successive air gap adjustments  
 $P_b$  = brake power absorption at 20° (50 Hz)  
 c/h = starts per hour

Legende:

$M_b$  = statisches max. Bremsmoment (± 15%)  
 $t_1$  = Bremsenansprechzeit  
 $t_2$  = Bremsverzögerung  
 $W_{max}$  = max. Energie pro Bremsung (Wärmeleistung der Bremse)  
 $W$  = Bremsenergie zwischen zwei Einstellungen des Luftspalts  
 $P_b$  = bei 20° von der Bremse aufgenommene Leistung (50 Hz)  
 c/h = Schaltungen pro stunde

Légende:

$M_b$  = couple de freinage statique max (15%)  
 $t_1$  = temps de déblocage frein  
 $t_2$  = retard de freinage  
 $W_{max}$  = énergie max par freinage (capacité thermique du frein)  
 $W$  = énergie de freinage entre deux réglages successifs de l'entrefer  
 $P_b$  = puissance absorbée par le frein à 20° (50 Hz)  
 c/h = démarrages horaires

N.B.

I valori di  $t_1$  e  $t_2$  riportati in tabella sono riferiti al freno tarato alla coppia nominale, traferro medio e tensione nominale.

NOTE

Values  $t_1$  and  $t_2$  in the table refer to a brake set at rated torque, medium air gap and rated voltage.

HINWEIS:

Die in der Tabelle angegebenen Werte  $t_1$  und  $t_2$  beziehen sich auf eine Bremse, die auf das Nenndrehmoment, einen mittleren Luftspalt und die Standardspannung eingestellt ist.

N.B.

Les valeurs de  $t_1$  et  $t_2$  indiquées dans le tableau se réfèrent au frein étalonné au couple nominal, entrefer moyen et tension nominale.



**- Collegamenti freno FA**

**- FA brake connections**

**- Abschlüsse - Bremstyp FA**

**- Raccordements frein FA**

Per i motori con alimentazione del freno derivata direttamente dall'alimentazione motore i collegamenti alla morsetteria corrispondono a quanto riportato nello schema (47):

The diagram (47) shows the required connections to terminal box when brake is to be connected directly to motor power supply:

Bei den Motoren mit direkter Bremsspannungsversorgung müssen die Anschlüsse im Klemmenkasten entsprechend den Angaben im Schema (47) angeschlossen werden:

Pour les moteurs avec alimentation du frein dérivant directement de l'alimentation moteur, les raccordements à la boîte à bornes correspondent aux indications du schéma (47) :

(47)

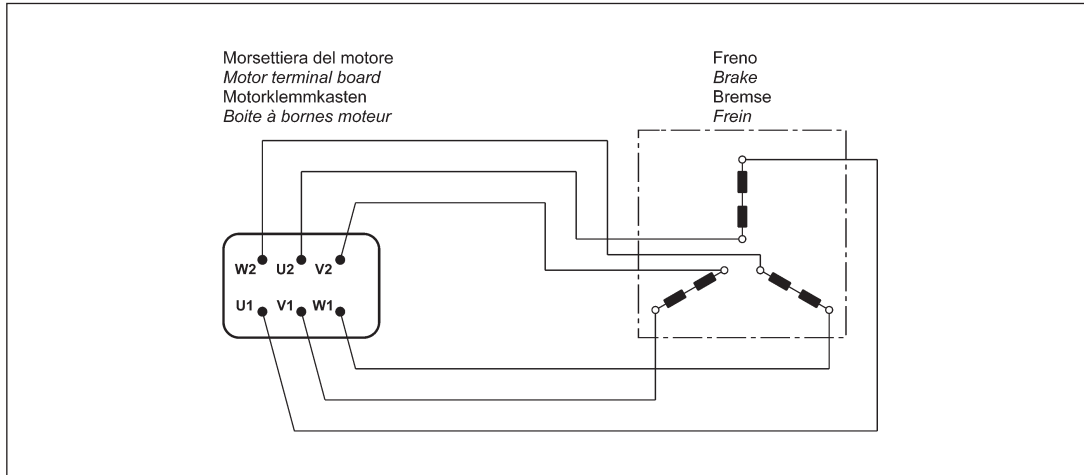

Per i motori a doppia polarità e, quando richiesto, per i motori ad una velocità con alimentazione da linea separata è prevista una morsetteria ausiliaria a 6 morsetti per il collegamento del freno; in questa esecuzione i motori prevedono la scatola coprimorsetti maggiorata. Vedi schema (48):

Switch-pole motors and, at request, single-pole motors with separate power supply line are equipped with an auxiliary terminal board with 6 terminals for brake connection. In this version, motors feature a larger terminal box. See diagram (48):

Bei den polumschaltbaren Motoren und, auf Anfrage, auch bei den einpoligen Motoren mit separater Bremsversorgung ist für den Anschluss der Bremse ein Hilfsklemmenkasten mit 6 Klemmen vorgesehen. In diesen Ausführungen haben die Motoren einen größeren Klemmenkasten. Siehe Schema (48):

Pour les moteurs à double polarité et, lorsque cela est requis, pour les moteurs à une vitesse avec alimentation depuis ligne séparée, une boîte à bornes auxiliaire à 6 bornes est prévue pour le raccordement du frein ; dans cette exécution les moteurs prévoient un couvercle bornier majoré. Voir schéma (48) :

(48)

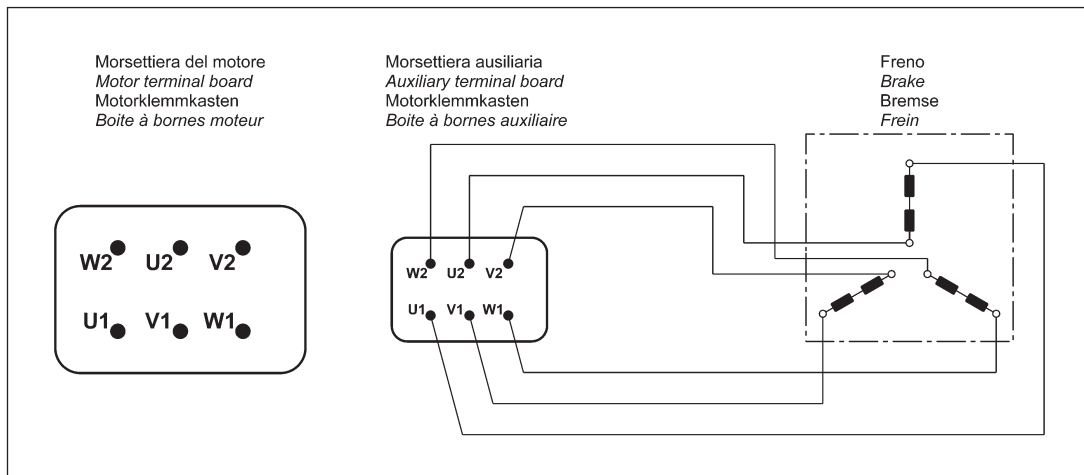



**M27 - MOTORI AUTOFRENANTI  
IN C.A. TIPO BN\_BA**

**M27 - AC BRAKE MOTORS  
TYPE BN\_BA**

**M27 - WECHSELSTROMBREMS-  
MOTOREN MIT W.S.-  
BREMSE TYP BN\_BA**

**M27 - MOTEURS FREIN EN C.A.  
TYPE BN\_BA**

- **Grandezze:** BN 63 ... BN 132M

- **Frame sizes:** BN 63 ... BN 132M

- **Baugrößen:** BN 63 ... BN 132M

- **Tailles :** BN 63 ... BN 132M

(49)

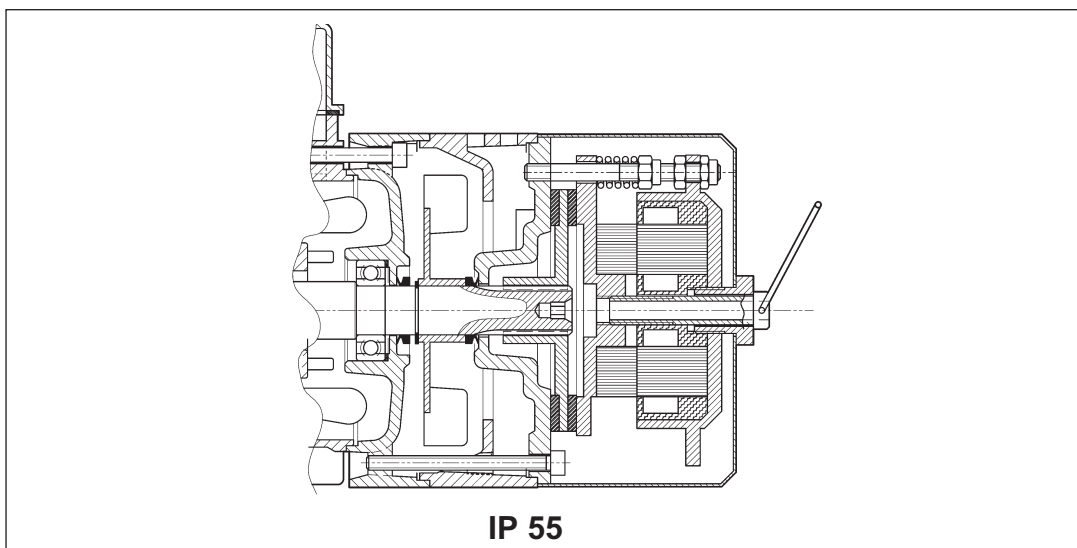

Freno elettromagnetico con alimentazione in **corrente alternata** trifase, fissato con viti allo scudo convogliatore.

Disco freno in acciaio scorrevole assialmente sull'albero motore scanalato (mozzo trascinatore in acciaio calettato sull'albero per grandezza 132).

I motori sono forniti con freno tarato alla massima coppia. La coppia freno è regolabile con continuità agendo sulle viti di compressione delle molle; il campo di regolazione consentito è  $30\% M_{bMAX} < M_b < M_{bMAX}$  ( $M_{bMAX}$  è il momento frenante max riportato in tab. (52)).

Di serie i motori sono forniti completi di vite per lo sblocco manuale del freno, con mantenimento della posizione di rilascio per consentire la rotazione dell'albero motore.

La vite di sblocco deve essere smontata dopo l'utilizzo per assicurare il corretto funzionamento del freno ed evitare situazioni potenzialmente pericolose.

Il freno BA, oltre alle elevate caratteristiche dinamiche tipiche dei freni in corrente alternata, presenta una costruzione robusta con energia di frenatura aumentata che lo rendono particolarmente idoneo a servizi pesanti oltre che in applicazioni dove sono richieste frequenze di manovra elevate e tempi d'intervento molto rapidi.

*Electromagnetic brake operates from three-phase **alternated current** power supply and is bolted onto conveyor shield.*

*Steel brake disc slides axially on splined motor shaft (steel drive hub is shrunk onto shaft on frame size 132).*

*Factory setting is maximum brake torque.*

*Step less braking torque adjustment by screws which compress the brake springs. Allowed adjustment range is  $30\% M_{bMAX} < M_b < M_{bMAX}$  ( $M_{bMAX}$  is maximum braking torque as shown in tab. (52)).*

*Motors are supplied complete with manual brake release screw as standard. Screw may be locked in the release position to allow for motor shaft rotation.*

*The brake release screw must be removed after use to ensure proper brake operation and avoid potentially dangerous conditions.*

*In addition to the high dynamic characteristics typical of AC brakes, a sturdy design and increased braking energy make the BA brake ideal for heavy-duty applications as well as applications requiring frequent stop/starts and very fast response time.*

Elektromagnetische Bremse mit Drehstromversorgung, die mittels Schrauben am Motorschild des Motors befestigt ist. Die Bremscheibe (Stahl) gleitet axial auf der Rotorwelle (bei Baugröße 132 über einem auf die Welle aufgezogenem Mitnehmer aus Stahl). Die Motoren werden mit einer auf das maximale Drehmoment des Motors eingestellten Bremse geliefert. Das Bremsdrehmoment ist durch Betätigen der Federdruckschrauben stufenlos regelbar. Der zulässige Einstellbereich beträgt  $30\% M_{bMAX} < M_b < M_{bMAX}$  ( $M_{bMAX}$  steht für den max. Bremsmoment, das in der Tab. (52) angegeben wird).

Die Motoren werden serienmäßig mit einer Schraube zur manuelle Bremslüftung geliefert; die arretierbar ist, um ein Drehen der Motorwelle zu ermöglichen. Diese Schraube muss im Betrieb des Motors wieder abmontiert werden, damit die korrekte Funktion der Bremse gesichert ist. Die Bremse vom Typ BA zeichnet sich durch ihre dynamischen Eigenschaften und die robuste Bauweise aus, durch die sie eine erhöhte Bremsenergie abzugeben kann. Diese Bremstypen eignen sich besonders für einen Einsatz unter harten Bedingungen und überall dort, wo häufige Schaltfrequenzen und schnelle Ansprechzeiten gefordert werden.

*Frein électromagnétique avec alimentation en **courant alternatif** triphasé, fixé avec des vis au bouclier.*

*Disque frein en acier coulissant de façon axiale sur l'arbre moteur rainuré (moyeu d'entraînement en acier calé sur l'arbre pour la taille 132).*

*Les moteurs sont fournis avec frein étalonné au couple maximal. Le couple de freinage est réglable en continu en intervenant sur les vis de compression des ressorts ; la plage de réglage autorisé est de  $30\% M_{bMAX} < M_b < M_{bMAX}$  ( $M_{bMAX}$  étant le couple de freinage maximum indiqué dans le tab. (52)).*

*De série, les moteurs sont fournis avec vis de déblocage manuel du frein, avec maintien de la position de relâchement afin de permettre la rotation de l'arbre moteur.*

*La vis de déblocage doit être démontée après utilisation afin de garantir le fonctionnement correct du frein et d'éviter les situations potentiellement dangereuses. Le frein BA, outre les caractéristiques dynamiques élevées typiques des freins en courant alternatif, est de fabrication robuste avec énergie de freinage majorée, ce qui le rend particulièrement adapté pour les services difficiles ainsi que pour les applications nécessitant des fréquences de manœuvre élevées et des temps d'intervention très rapides.*



**- Grado di protezione**

È disponibile un'unica esecuzione, con grado di protezione IP55.

**- Degree of protection**

Only available with degree of protection IP55.

**- Schutzart**

Es ist eine nur die Ausführung in Schutzklasse IP55 verfügbar.

**- Degré de protection**

Il est disponible en une exécution unique, avec degré de protection IP55.

**- Alimentazione freno BA**

Nei motori a singola polarità l'alimentazione della bobina freno è derivata direttamente dalla morsettiera motore e la tensione del freno quindi coincide con la tensione del motore. In questo caso la tensione del freno può essere omessa dalla designazione.

Per i motori a doppia polarità, e per i motori con alimentazione separata del freno, è presente una morsettiera ausiliaria con 6 terminali per il collegamento alla linea del freno. In entrambi i casi il valore di tensione del freno dovrà essere specificato in designazione.

Nella tabella seguente sono riportate le condizioni di alimentazione standard del freno in c.a. per i motori a singola e doppia polarità:

**- BA brake power supply**

In single-pole motors, power supply is brought to the brake coil direct from the motor terminal box. As a result, brake voltage and motor voltage are the same. In this case, brake voltage indication may be omitted in the designation.

Switch-pole motors and motors with separate brake power supply feature an auxiliary terminal board with 6 terminals for connection to brake line. In both cases, brake voltage indication in the designation is mandatory. The following table reports standard AC brake power supply ratings for single- and switch-pole motors:

**- Stromversorgung - Bremstyp BA**

Bei den einpoligen Motoren wird die Versorgung der Bremsenspule direkt vom Motorklemmenkasten abgezweigt, das bedeutet also, dass die Spannung der Bremse mit der Motorspannung übereinstimmt. In diesem Fall braucht die Bremsenspannung nicht extra angegeben werden. Für polumschaltbaren Motoren und für eine separate Bremsversorgung ist eine Hilfsklemmenleiste mit 6 Anschlüssen vorgesehen, die einen Anschluss der Bremse ermöglichen. In beiden Fällen muss die Bremsenspannung bei der Bestellung angegeben werden.

In der nachstehenden Tabelle werden für die einpoligen und die polumschaltbaren Motoren die Standardversorgung der Wechselstrombremsen angegeben.

**- Alimentation frein BA**

Sur les moteurs à simple polarité, l'alimentation de la bobine frein dérive directement du bornier moteur, par conséquent, la tension du frein coïncide avec la tension du moteur. Dans ce cas, la tension du frein peut être omise de la désignation.

Pour les moteurs à double polarité et les moteurs avec alimentation séparée du frein, un boîte à bornes auxiliaire avec 6 bornes pour le raccordement au réseau du frein, est présente. Dans les deux cas, la valeur de tension du frein doit être spécifiée dans la désignation.

Le tableau suivant indique les conditions d'alimentation standard du frein en c.a. pour les moteurs à simple et double polarité :

(50)	<b>Motori a singola polarità</b> <i>Single-speed motors</i> <b>Einpolige Motoren</b> <i>Moteurs à simple polarité</i>	<b>BN 63 ... BN 132</b>
		230Δ / 400Y V ± 10% – 50 Hz
		265Δ / 460Y ± 10% - 60 Hz

(51)	<b>Motori a doppia polarità</b> (alimentazione da linea separata) <i>Switch-pole motors (separate power supply line)</i> <b>Polumschaltbare Motoren</b> (separate Versorgung) <i>Moteurs à double polarité (alimentation depuis ligne séparée)</i>	<b>BN 63 ... BN 132</b>
		230Δ / 400Y V ± 10% – 50 Hz
		460Y – 60 Hz

Se non diversamente specificato, l'alimentazione standard del freno è 230Δ /400Y V - 50 Hz.

Su richiesta, sono disponibili tensioni speciali, nel campo 24...690 V, 50... 60 Hz.

Unless otherwise specified, standard brake power supply is 230Δ /400Y V - 50 Hz.

Special voltages in the 24...690 V, 50... 60 Hz range are available at request.

Falls nicht anderweitig angegeben, beträgt die Standardversorgung der Bremse 230Δ /400Y V - 50 Hz.

Auf Anfrage können Sonderspannungen von 24...690 V, 50... 60 Hz geliefert werden.

Sauf spécification contraire, l'alimentation standard du frein est 230Δ /400Y V - 50 Hz.

Sur demande, des tensions spéciales sont disponibles dans la plage 24...690 V, 50... 60 Hz.





**- Dati tecnici freni BA**

Nella tabella sottostante sono riportati i dati tecnici dei freni in c.a., tipo BA.

**- BA brake technical specifications**

The table below reports the technical specifications for AC brakes type BA.

**- Technische Daten der Bremsen vom Typ BA**

In der nachstehenden Tabelle werden die technischen Daten der Wechselstrombremsen vom Typ BA angegeben:

**- Caractéristiques techniques freins BA**

Le tableau ci-dessous indique les caractéristiques techniques des freins en c.a., type BA.

(52)

Freno Brake Bremsen Frein	Coppia frenante $M_b$ Brake torque $M_b$ Bremsmoment $M_b$ Couple de freinage $M_b$	Rilascio Release Anspruchzeit Déblocage	Frenatura Braking Bremszeit Freinage	W max			W	Pb
				[J]				
				10 c/h	100 c/h	1000 c/h		
<b>BA 60</b>	5	5	20	4000	1500	180	30	60
<b>BA 70</b>	8	6	25	7000	2700	300	60	75
<b>BA 80</b>	18	6	25	10000	3100	350	80	110
<b>BA 90</b>	35	8	35	13000	3600	400	88	185
<b>BA 100</b>	50	8	35	18000	4500	500	112	225
<b>BA 110</b>	75	8	35	28000	6800	750	132	270
<b>BA 140</b>	150	15	60	60000	14000	1500	240	530

**Legenda:**

$M_b$  = max coppia frenante statica ( $\pm 15\%$ )  
 $t_1$  = tempo di rilascio del freno  
 $t_2$  = ritardo di frenatura  
 $W_{max}$  = energia max per frenata (capacità termica del freno)  
 $W$  = energia di frenatura tra due regolazioni successive del traferro  
 $P_b$  = potenza assorbita dal freno a 20°C (50 Hz)  
 c/h = avviamenti orari

**Legenda:**

$M_b$  = max static braking torque (15%)  
 $t_1$  = brake release response time  
 $t_2$  = brake engagement time  
 $W_{max}$  = max energy per brake operation (brake thermal capacity)  
 $W$  = braking energy between two successive air gap adjustments  
 $P_b$  = brake power absorption at 20° (50 Hz)  
 c/h = starts per hour

**Legende:**

$M_b$  = statisches max. Bremsmoment ( $\pm 15\%$ )  
 $t_1$  = Bremsenansprechzeit  
 $t_2$  = Bremsverzögerung  
 $W_{max}$  = max. Energie pro Bremsung (Wärmeleistung der Bremse)  
 $W$  = Bremsenergie zwischen zwei Einstellungen des Luftspalts  
 $P_b$  = bei 20° von der Bremse aufgenommene Leistung (50 Hz)  
 c/h = Schaltungen pro Stunde

**Légende:**

$M_b$  = couple de freinage statique max (15%)  
 $t_1$  = temps de déblocage frein  
 $t_2$  = retard de freinage  
 $W_{max}$  = énergie max par freinage (capacité thermique du frein)  
 $W$  = énergie de freinage entre deux réglages successifs de l'entrefer  
 $P_b$  = puissance absorbée par le frein à 20° (50 Hz)  
 c/h = démarrages horaires

**N.B.**

I valori di  $t_1$  e  $t_2$  riportati in tabella sono riferiti al freno tarato alla coppia nominale, traferro medio e tensione nominale.

**NOTE :**

Values  $t_1$  and  $t_2$  in the table refer to a brake set at rated torque, medium air gap and rated voltage.

**HINWEIS:**

Die in der Tabelle angegebenen Werte  $t_1$  und  $t_2$  beziehen sich auf eine Bremse, die auf das Nenndrehmoment, einen mittleren Luftspalt und die Standardspannung eingestellt ist.

**N.B.**

Les valeurs de  $t_1$  et  $t_2$  indiquées dans le tableau se réfèrent au frein étaloné au couple nominal, entrefer moyen et tension nominale.

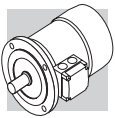

**- Collegamenti freno BA**

**- BA brake connections**

**- Anschlüsse - Bremstyp BA**

**- Raccordements frein BA**

Per i motori con alimentazione del freno derivata direttamente dall'alimentazione motore i collegamenti alla morsetteria corrispondono a quanto riportato nello schema (53):

The diagram (53) shows the required connections to terminal box when brake is to be connected directly to motor power supply:

Bei den Motoren mit einer direkten von der Motorspannung gespeisten Bremsversorgung müssen die Bremsen entsprechend der Angaben im Schema (53) angeschlossen werden:

Pour les moteurs avec alimentation du frein dérivant directement de l'alimentation moteur, les raccordements à la boîte à bornes correspondent aux indications du schéma (53) :

(53)

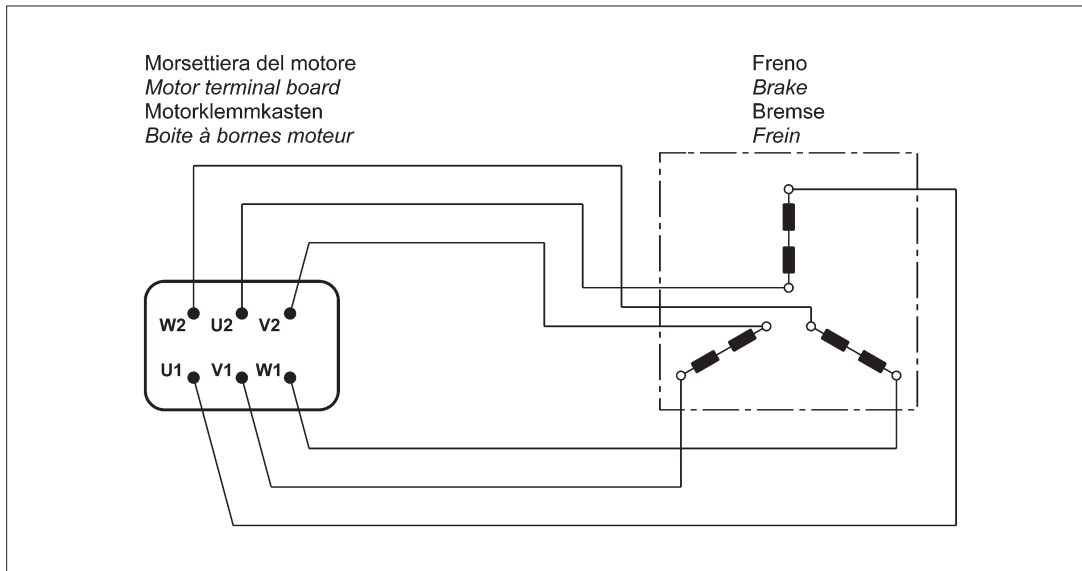

Per i motori a doppia polarità e, quando richiesto, per i motori ad una velocità con alimentazione da linea separata è prevista una morsetteria ausiliaria a 6 morsetti per il collegamento del freno; in questa esecuzione i motori prevedono la scatola coprimorsetti maggiorata. Vedi schema (54):

Switch-pole motors and, at request, single-pole motors with separate power supply line are equipped with an auxiliary terminal board with 6 terminals for brake connection. In this version, motors feature a larger terminal box. See diagram (54):

Bei den polumschaltbaren Motoren und, auf Anfrage, auch bei den eintpoligen Motoren mit separater Bremsversorgung ist für den Anschluss der Bremse ein Hilfsklemmenkasten mit 6 Klemmen vorgesehen. In dieser Ausführungen haben die Motoren einen größeren Klemmenkasten. Siehe Schema (54):

Pour les moteurs à double polarité et, lorsque cela est requis, pour les moteurs à une vitesse avec alimentation depuis ligne séparée, une boîte à bornes auxiliaire à 6 bornes est prévue pour le raccordement du frein ; dans cette exécution les moteurs prévoient un couvercle bornier majoré. Voir schéma (54) :

(54)

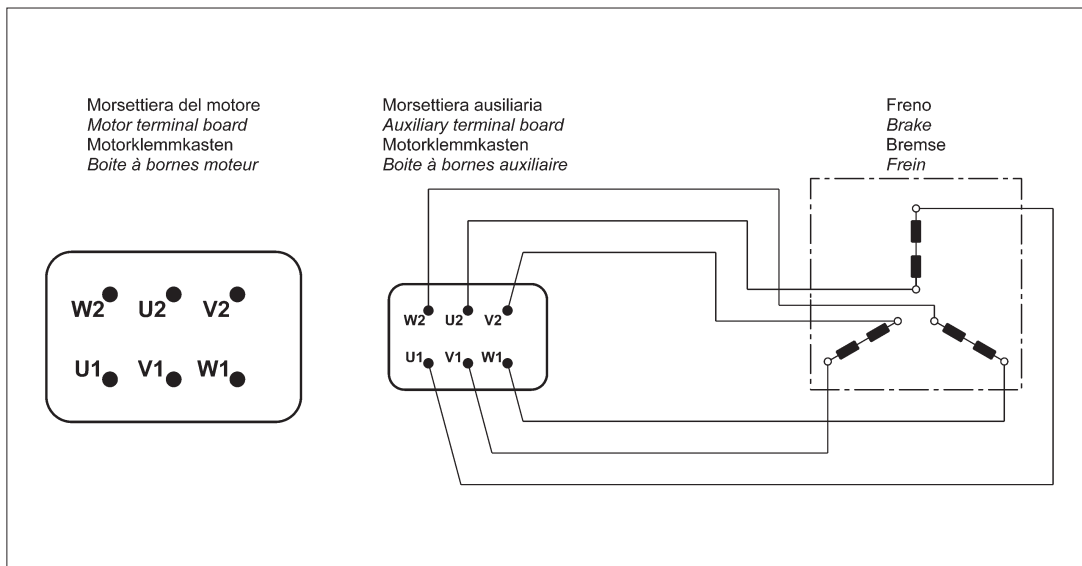

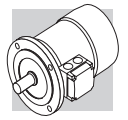

---

M28 - DATI TECNICI MOTORI

M28 - MOTOR RATING CHARTS

M28 - MOTORENAUSWAHL-  
TABELLEN



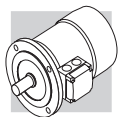

M28 - DONNEES TECHNIQUES  
DES MOTEURS



**2 P**

**3000 min<sup>-1</sup> - S1**

**50 Hz**

Pn kW		n min <sup>-1</sup>	Mn Nm	IE1	η (100%) %	η (75%) %	η (50%) %	cos φ	In [400V] A	Is In	Ms Mn	Ma Mn	Jm x 10 <sup>-4</sup> kgm <sup>2</sup>	IM B5 	freno c.c. / d.c. brake G.S.-bremse / frein c.c.				freno c.a. / a.c. brake W.S.-bremse / frein c.a.													
															FD		FA		BA		FA		BA									
															Mod.	Mb Nm	Z <sub>0</sub> 1/h	Jm x 10 <sup>-4</sup> kgm <sup>2</sup>	IM B5 	Mod.	Mb Nm	Z <sub>0</sub> 1/h	Jm x 10 <sup>-4</sup> kgm <sup>2</sup>	IM B5 	Mod.	Mb max Nm	Z <sub>0</sub> 1/h	Jm x 10 <sup>-4</sup> kgm <sup>2</sup>	IM B5 			
0.18	<b>BN 63A</b>	2	2730	0.63	59.9	56.9	51.9	0.77	0.56	3.0	2.1	2.0	2.0	3.5	<b>FD 02</b>	1.75	3900	4800	2.6	5.2	<b>FA 02</b>	1.75	5	3500	4.0	5.0	<b>BA 60</b>	5	3500	4.0	5.8	
0.25	<b>BN 63B</b>	2	2740	0.87	66.0	64.8	64.8	0.76	0.72	3.3	2.3	2.3	2.3	3.9	<b>FD 02</b>	1.75	3900	4800	3.0	5.6	<b>FA 02</b>	1.75	5	3600	4.3	5.4	<b>BA 60</b>	5	3600	4.3	6.2	
0.37	<b>BN 63C</b>	2	2800	1.26	69.1	66.8	66.8	0.78	0.99	3.9	2.6	2.6	3.3	5.1	<b>FD 02</b>	3.5	3600	4500	3.9	6.8	<b>FA 02</b>	3.5	5	3500	5.3	6.6	<b>BA 60</b>	5	3500	5.3	7.4	
0.37	<b>BN 71A</b>	2	2820	1.25	73.8	73.0	70.6	0.76	0.95	4.8	2.8	2.6	3.5	5.4	<b>FD 03</b>	3.5	3000	4100	4.6	8.1	<b>FA 03</b>	3.5	8	3500	5.5	7.8	<b>BA 70</b>	8	3500	5.5	9.3	
0.55	<b>BN 71B</b>	2	2820	1.86	76.0	75.8	74.8	0.76	1.37	5.0	2.9	2.8	4.1	6.2	<b>FD 03</b>	5	2900	4200	5.3	8.9	<b>FA 03</b>	5	8	3600	6.1	8.6	<b>BA 70</b>	8	3600	6.1	10.1	
0.75	<b>BN 71C</b>	2	2810	2.6	76.6	76.2	76.2	0.76	1.86	5.1	3.1	2.8	5.0	7.3	<b>FD 03</b>	5	1900	3300	6.1	10	<b>FA 03</b>	5	8	3200	7.0	9.7	<b>BA 70</b>	8	3200	7.0	11.2	
0.75	<b>BN 80A</b>	2	2810	2.6	76.2	75.5	68.3	0.81	1.75	4.8	2.6	2.2	7.8	8.6	<b>FD 04</b>	5	1700	3200	9.4	12.5	<b>FA 04</b>	5	18	2800	10.8	12.4	<b>BA 80</b>	18	2800	10.8	13.9	
1.1	<b>BN 80B</b>	2	2800	3.8	76.4	76.2	75.0	0.81	2.57	4.8	2.8	2.4	9.0	9.5	<b>FD 04</b>	10	1500	3000	10.6	13.4	<b>FA 04</b>	10	18	2700	12.0	13.3	<b>BA 80</b>	18	2700	12.0	14.8	
1.5	<b>BN 80C</b>	2	2800	5.1	79.1	79.5	77.2	0.81	3.4	4.9	2.7	2.4	11.4	11.3	<b>FD 04</b>	15	1300	2600	13.0	15.2	<b>FA 04</b>	15	18	2400	14.4	15.1	<b>BA 80</b>	18	2400	14.4	16.6	
1.5	<b>BN 90SA</b>	2	2870	5.0	82.0	81.5	78.1	0.80	3.4	5.9	2.7	2.6	12.5	12.3	<b>FD 14</b>	15	900	2200	14.1	16.5	<b>FA 14</b>	15	35	1600	19.5	16.4	<b>BA 90</b>	35	1600	19.5	19.6	
1.85	<b>BN 90SB</b>	2	2880	6.1	82.5	82.0	75.4	0.80	4.0	6.2	2.9	2.6	16.7	14	<b>FD 14</b>	15	900	2200	18.3	18.2	<b>FA 14</b>	15	35	1700	23.7	18.1	<b>BA 90</b>	35	1700	23.7	21.3	
2.2	<b>BN 90L</b>	2	2880	7.3	82.7	82.1	80.8	0.80	4.8	6.3	2.9	2.7	16.7	14	<b>FD 05</b>	26	900	2200	21	20	<b>FA 05</b>	26	35	1700	24	20.7	<b>BA 90</b>	35	1700	24	21.3	
3	<b>BN 100L</b>	2	2860	10.0	81.5	81.3	77.4	0.79	6.7	5.6	2.6	2.2	31	20	<b>FD 15</b>	26	700	1600	35	26	<b>FA 15</b>	26	50	1300	43	27	<b>BA 100</b>	50	1300	43	30	
4	<b>BN 100LB</b>	2	2870	13.3	83.1	83.0	77.8	0.80	8.7	5.8	2.7	2.5	39	23	<b>FD 15</b>	40	450	900	43	29	<b>FA 15</b>	40	50	850	51	30	<b>BA 100</b>	50	850	51	33	
4	<b>BN 112M</b>	2	2900	13.2	85.5	84.5	83.0	0.82	8.2	6.9	3.0	2.9	57	28	<b>FD 06S</b>	40	—	950	66	39	<b>FA 06S</b>	40	75	850	73	40	<b>BA 110</b>	75	850	73	41	
5.5	<b>BN 132SA</b>	2	2890	18.2	84.7	84.5	81.2	0.84	11.2	5.9	2.6	2.2	101	35	<b>FD 06</b>	50	—	600	112	48	<b>FA 06</b>	50	150	500	151	49	<b>BA 140</b>	150	500	151	67	
7.5	<b>BN 132SB</b>	2	2900	25	86.5	86.3	84.4	0.85	14.7	6.4	2.6	2.2	145	42	<b>FD 06</b>	50	—	550	154	55	<b>FA 06</b>	50	150	450	195	56	<b>BA 140</b>	150	450	195	74	
9.2	<b>BN 132M</b>	2	2930	30	87.0	86.5	83.6	0.86	17.7	6.7	2.8	2.3	178	53	<b>FD 56</b>	75	—	430	189	66	<b>FA 06</b>	75	150	400	228	67	<b>BA 140</b>	150	400	228	85	
11	<b>BN 160MR</b>	2	2920	36	87.6	87.0	86.0	0.88	20.6	6.9	2.9	2.5	210	65																		
15	<b>BN 160MB</b>	2	2930	49	89.6	89.4	88.0	0.86	28.1	7.1	2.6	2.3	340	84																		
18.5	<b>BN 160L</b>	2	2930	60	90.4	90.1	89.0	0.86	34	7.6	2.7	2.3	420	97																		
22	<b>BN 180M</b>	2	2930	72	89.9	89.7	89.5	0.88	40	7.8	2.6	2.4	490	109																		
30	<b>BN 200LA</b>	2	2930	98	90.7	90.1	87.6	0.89	54	7.8	2.7	2.9	770	140																		

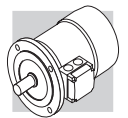



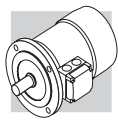

		freno c.c. / d.c. brake G.S.-bremse / frein c.c.										freno c.a. / a.c. brake W.S.-bremse / frein c.a.																													
Ph	kW		n	Mn	IE1	η (100%)	η (75%)	η (50%)	cos φ	In	Is / In	Ms / Mn	Ma / Mn	Jm x 10 <sup>-4</sup> kgm <sup>2</sup>	IM B5 	FD				FA				BA																	
																Mod	Mb	Z <sub>o</sub>	Jm x 10 <sup>-4</sup> kgm <sup>2</sup>	IM B5 	Mod.	Mb	Z <sub>o</sub>	Jm x 10 <sup>-4</sup> kgm <sup>2</sup>	IM B5 	Mod.	Mb max	Z <sub>o</sub>	Jm x 10 <sup>-4</sup> kgm <sup>2</sup>	IM B5 											
0.06			1340	0.43		46.8	44.2	41.3	0.65	0.28	2.6	2.3	2.0	1.5	3.1																										
0.09			1350	0.64		51.7	47.6	42.9	0.60	0.42	2.6	2.5	2.4	1.5	3.1																										
0.12			1350	0.85		59.8	56.2	47.0	0.62	0.47	2.6	1.9	1.8	2.0	3.5																										
0.18			1320	1.30		54.8	52.9	52.5	0.67	0.71	2.6	2.2	2.0	2.3	3.9																										
0.25			1340	1.78		65.3	65.0	57.9	0.69	0.80	2.7	2.1	1.9	3.3	5.1																										
0.25			1380	1.73		63.7	62.2	59.1	0.73	0.78	3.3	1.9	1.7	5.8	5.1																										
0.37			1370	2.6		66.8	66.7	63.0	0.76	1.05	3.7	2.0	1.9	6.9	5.9																										
0.55			1380	3.8		69.0	68.9	68.8	0.74	1.55	4.1	2.3	2.3	9.1	7.3																										
0.55			1390	3.8		72.0	71.3	69.7	0.77	1.43	4.1	2.3	2.0	15	8.2																										
0.75			1400	5.1	●	75.0	74.5	69.3	0.78	1.85	4.9	2.7	2.5	20	9.9																										
1.1			1400	7.5	●	75.5	76.2	70.4	0.78	2.70	5.1	2.8	2.5	25	11.3																										
1.1			1390	7.6	●	76.5	76.2	72.2	0.77	2.70	4.6	2.6	2.2	21	12.2																										
1.5			1410	10.2	●	78.7	78.5	74.9	0.77	3.6	5.3	2.8	2.4	28	13.6																										
1.85			1390	12.7	●	78.6	78.9	77.2	0.79	4.3	5.1	2.8	2.6	30	15.1																										
2.2			1410	14.9	●	81.1	81.4	79.9	0.75	5.2	4.5	2.2	2.0	40	18.3																										
3			1410	20	●	82.6	83.8	83.7	0.77	6.8	5.0	2.3	2.2	54	22																										
4			1430	27	●	84.4	84.2	81.6	0.81	8.4	5.6	2.7	2.5	98	30																										
5.5			1440	36	●	84.7	84.8	82.5	0.81	11.6	5.5	2.3	2.2	213	44																										
7.5			1440	50	●	86.0	86.3	85.3	0.81	15.5	5.7	2.5	2.4	270	53																										
9.2			1440	61	●	88.4	88.6	87.5	0.80	18.8	5.9	2.7	2.5	319	59																										
11			1440	73	●	87.6	87.8	86.0	0.81	22.4	6.0	2.7	2.5	360	70																										
15			1460	98	●	88.7	88.5	88.4	0.81	30	6.0	2.3	2.1	650	99																										
18.5			1460	121	●	89.3	89.5	89.2	0.81	37	6.2	2.6	2.5	790	115																										
22			1460	144	●	89.9	90.0	90.0	0.80	44	6.4	2.5	2.5	1250	135																										
30			1460	196	●	91.4	91.7	91.0	0.80	59	7.1	2.7	2.8	1650	157																										







# 6 P

## 1000 min<sup>-1</sup> - S1

## 50 Hz

Ph	kW		n min <sup>-1</sup>	Mn Nm	IE1	η (100%) %	η (75%) %	η (50%) %	cos φ	In A	Is In	Ms Mn	Ma Mn	Jm x 10 <sup>-4</sup> kgm <sup>2</sup>	IM B5 	freno c.c. / d.c. brake G.S.-bremse / frein c.c.						freno c.a. / a.c. brake W.S.-bremse / frein c.a.												
																FD			FA			BA			FD			FA			BA			
																Mod.	Mb Nm	Z <sub>0</sub> 1/h	SB	Jm x 10 <sup>-4</sup> kgm <sup>2</sup>	IM B5 	Mod.	Mb Nm	Z <sub>0</sub> 1/h	Mb	Z <sub>0</sub> 1/h	Jm x 10 <sup>-4</sup> kgm <sup>2</sup>	IM B5 	Mod.	Mb Nm	Z <sub>0</sub> 1/h	Mb	Z <sub>0</sub> 1/h	Jm x 10 <sup>-4</sup> kgm <sup>2</sup>
0.09	0.09	<b>BN 63A</b>	6	880	0.98	41.0	41.0	32.9	0.53	0.60	2.1	2.1	1.8	3.4	4.6	<b>FD 02</b>	3.5	9000	14000	—	2100	177	42	<b>FA 06S</b>	60	—	2100	177	42	<b>BA 110</b>	75	2000	184	45
0.12	0.12	<b>BN 63B</b>	6	870	1.32	45.0	44.0	41.8	0.60	0.64	2.1	1.9	1.7	3.7	4.9	<b>FD 02</b>	3.5	9000	14000	—	2100	177	42	<b>FA 06</b>	75	—	1400	226	49	<b>BA 140</b>	150	1200	266	68
0.18	0.18	<b>BN 71A</b>	6	900	1.91	55.0	55.5	51.0	0.69	0.68	2.6	1.9	1.7	8.4	5.5	<b>FD 03</b>	5.0	8100	13500	—	2100	177	42	<b>FA 07</b>	100	—	1200	305	58	<b>BA 140</b>	150	1050	345	77
0.25	0.25	<b>BN 71B</b>	6	900	2.7	62.0	58.5	51.4	0.71	0.82	2.6	1.9	1.7	10.9	6.7	<b>FD 03</b>	5.0	7800	13000	—	2100	177	42	<b>FA 07</b>	100	—	1200	305	58	<b>BA 140</b>	150	1050	345	77
0.37	0.37	<b>BN 71C</b>	6	910	3.9	66.0	60.0	53.3	0.69	1.17	3.0	2.4	2.0	12.9	7.7	<b>FD 53</b>	7.5	5100	9500	—	2100	177	42	<b>FA 07</b>	150	—	1050	406	72	<b>BA 140</b>	150	1000	433	88
0.37	0.37	<b>BN 80A</b>	6	910	3.9	68.0	67.4	63.3	0.68	1.15	3.2	2.2	2.0	21	9.9	<b>FD 04</b>	10	5200	8500	—	2100	177	42	<b>FA 08</b>	170	—	900	815	112	<b>BA 80</b>	18	8000	24	15.2
0.55	0.55	<b>BN 80B</b>	6	920	5.7	70.0	69.8	64.3	0.68	1.67	3.9	2.6	2.2	25	11.3	<b>FD 04</b>	15	4800	7200	—	2100	177	42	<b>FA 08</b>	200	—	800	1045	133	<b>BA 80</b>	18	6800	28	16.6
0.75	0.75	<b>BN 80C</b>	6	920	7.8	70.0	70.0	64.4	0.65	2.38	3.8	2.5	2.2	28	12.2	<b>FD 04</b>	15	3400	6400	—	2100	177	42	<b>FA 08</b>	300	—	600	1750	170	<b>BA 80</b>	18	6100	31	17.5
0.75	0.75	<b>BN 90S</b>	6	920	7.8	70.0	69.0	64.2	0.68	2.27	3.8	2.4	2.2	26	12.6	<b>FD 14</b>	15	3400	6500	—	2100	177	42	<b>FA 14</b>	15	—	900	815	113	<b>BA 90</b>	35	5500	33	19.9
1.1	1.1	<b>BN 90L</b>	6	920	11.4	72.9	72.6	69.1	0.69	3.2	3.9	2.3	2.0	33	15	<b>FD 05</b>	26	2700	5000	—	2100	177	42	<b>FA 05</b>	26	—	5000	37	22	<b>BA 90</b>	35	4600	40	22
1.5	1.5	<b>BN 100LA</b>	6	940	15.2	75.2	74.2	70.3	0.72	4.0	4.1	2.1	2.0	82	22	<b>FD 15</b>	40	1900	4100	—	2100	177	42	<b>FA 15</b>	40	—	4100	86	29	<b>BA 100</b>	50	3800	94	32
1.85	1.85	<b>BN 100LB</b>	6	930	19.0	76.6	72.8	62.6	0.73	4.8	4.6	2.1	2.0	95	24	<b>FD 15</b>	40	1700	3600	—	2100	177	42	<b>FA 15</b>	40	—	3600	99	31	<b>BA 100</b>	50	3400	107	34
2.2	2.2	<b>BN 112M</b>	6	940	22	78.5	79.0	76.5	0.73	5.5	4.8	2.2	2.0	168	32	<b>FD 06S</b>	60	—	2100	—	2100	177	42	<b>FA 06S</b>	60	—	2100	177	44	<b>BA 110</b>	75	2000	184	45
3	3	<b>BN 132S</b>	6	940	30	79.7	77.0	75.1	0.76	7.1	5.1	1.9	1.8	216	36	<b>FD 56</b>	75	—	1400	—	1400	226	49	<b>FA 06</b>	75	—	1400	226	50	<b>BA 140</b>	150	1200	266	68
4	4	<b>BN 132MA</b>	6	950	40	81.4	81.5	79.5	0.77	9.2	5.5	2.0	1.8	295	45	<b>FD 06</b>	100	—	1200	—	1200	305	58	<b>FA 07</b>	100	—	1200	318	63	<b>BA 140</b>	150	1050	345	77
5.5	5.5	<b>BN 132MB</b>	6	945	56	83.1	80.9	79.1	0.78	12.2	6.1	2.1	1.9	383	56	<b>FD 07</b>	150	—	1050	—	1050	406	72	<b>FA 07</b>	150	—	1050	406	74	<b>BA 140</b>	150	1000	433	88
7.5	7.5	<b>BN 160M</b>	6	955	75	85.0	85.0	84.8	0.81	15.7	5.9	2.2	2.0	740	83	<b>FD 08</b>	170	—	900	—	900	815	112	<b>FA 08</b>	170	—	900	815	113	<b>BA 140</b>	150	1200	266	68
11	11	<b>BN 160L</b>	6	960	109	86.4	86.5	85.9	0.81	22.7	6.6	2.5	2.3	970	103	<b>FD 08</b>	200	—	800	—	800	1045	133	<b>FA 08</b>	200	—	800	1045	133	<b>BA 140</b>	150	1050	345	77
15	15	<b>BN 180L</b>	6	970	148	87.7	88.0	87.3	0.82	30	6.2	2.0	2.4	1550	130	<b>FD 09</b>	300	—	600	—	600	1750	170	<b>FA 09</b>	300	—	600	1750	170	<b>BA 140</b>	150	1000	433	88
18.5	18.5	<b>BN 200LA</b>	6	960	184	88.6	88.0	87.3	0.81	37	5.9	2.0	2.3	1700	145	<b>FD 09</b>	400	—	450	—	450	1900	185	<b>FA 09</b>	400	—	450	1900	185	<b>BA 140</b>	150	1050	345	77

**8 P****750 min<sup>-1</sup> - S1****50 Hz**

Pn kW		n min <sup>-1</sup>	Mn Nm	η %	cos φ	In [400V] A	Is In	Ms Mn	Ma Mn	Jm x 10 <sup>-4</sup> kgm <sup>2</sup>	IM B5 	freno c.c. / d.c. brake G.S.-bremse / frein c.c.						freno c.a. / a.c. brake W.S.-bremse / frein c.a.											
												FD			FA			BA			FD			FA			BA		
												Mod.	Mb Nm	Zo 1/h NB SB	Jm x 10 <sup>-4</sup> kgm <sup>2</sup>	IM B5 	Mod.	Mb Nm	Zo 1/h	Jm x 10 <sup>-4</sup> kgm <sup>2</sup>	IM B5 	Mod.	Mb max Nm	Zo 1/h	Jm x 10 <sup>-4</sup> kgm <sup>2</sup>	IM B5 			
0.09	<b>BN 71A</b>	8	1.26	47	0.59	0.47	2.3	2.4	2.3	10.9	6.7	<b>FD 03</b>	3.5	9000	16000	12.0	9.4	<b>FA 03</b>	3.5	16000	12.0	9.1	<b>BA 70</b>	8.0	14000	12.9	10.6		
0.12	<b>BN 71B</b>	8	1.69	51	0.59	0.58	2.1	2.3	2.2	12.9	7.7	<b>FD 03</b>	5.0	9000	16000	14.0	10.4	<b>FA 03</b>	5.0	16000	14.0	10.1	<b>BA 70</b>	8.0	14000	14.9	11.6		
0.18	<b>BN 80A</b>	8	2.49	51	0.60	0.85	2.4	2.2	2.2	15	8.2	<b>FD 04</b>	5.0	6500	11000	16.6	12.1	<b>FA 04</b>	5.0	11000	16.6	12.0	<b>BA 80</b>	18.0	10000	—	—		
0.25	<b>BN 80B</b>	8	3.51	54	0.63	1.06	2.4	2.0	1.9	20	9.9	<b>FD 04</b>	10.0	6000	10000	22	13.8	<b>FA 04</b>	10.0	10000	23	13.7	<b>BA 80</b>	18.0	9500	24	15.2		
0.37	<b>BN 90S</b>	8	5.2	58	0.60	1.53	2.6	2.3	2.1	26	12.6	<b>FD 14</b>	15.0	4800	7500	28	16.8	<b>FA 14</b>	15.0	7500	28	16.7	<b>BA 90</b>	35	6800	33	19.9		
0.55	<b>BN 90L</b>	8	7.8	62	0.60	2.13	2.6	2.2	2.0	33	15	<b>FD 05</b>	26	4000	6400	37	21	<b>FA 05</b>	26	6400	37	22	<b>BA 90</b>	35	6000	40	22		
0.75	<b>BN 100LA</b>	8	10.2	68	0.63	2.53	3.4	1.9	1.7	82	22	<b>FD 15</b>	26	2800	4800	86	28	<b>FA 15</b>	26	4800	86	29	<b>BA 100</b>	50	4500	94	32		
1.1	<b>BN 100LB</b>	8	15.0	68	0.64	3.65	3.2	1.7	1.7	95	24	<b>FD 15</b>	40	2500	4000	99	30	<b>FA 15</b>	40	4000	99	31	<b>BA 100</b>	50	3700	107	34		
1.5	<b>BN 112M</b>	8	20.2	71	0.66	4.6	3.7	1.8	1.9	168	32	<b>FD 06S</b>	60	—	3000	177	42	<b>FA 06S</b>	60	3000	177	44	<b>BA 110</b>	75	2700	184	45		
2.2	<b>BN 132S</b>	8	29.6	75	0.66	6.4	3.8	1.8	2.0	295	45	<b>FD 56</b>	75	—	2300	305	58	<b>FA 06</b>	75	2300	305	56	<b>BA 140</b>	150	2000	345	77		
3	<b>BN 132MA</b>	8	40.4	76	0.69	8.3	3.9	1.6	1.8	370	53	<b>FD 06</b>	100	—	1900	394	69	<b>FA 07</b>	100	1900	406	74	<b>BA 140</b>	150	1700	433	88		

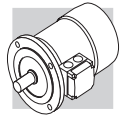

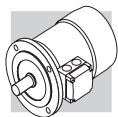









# 2/4 P

## 3000/1500 min<sup>-1</sup> - S1

## 50 Hz





Pn kW		n min <sup>-1</sup>	Mh Nm	η %	cos φ	In [400V] A	Is In	Ms Mn	Ma Mn	Jm x 10 <sup>-4</sup> kgm <sup>2</sup>	IM B5 	freno c.c. / d.c. brake G.S.-bremse / frein c.c.						freno c.a. / a.c. brake W.S.-bremse / frein c.a.											
												FD			FA			BA			FD			FA			BA		
												Mod.	Mb Nm	Zo 1/h NB SB	Jm x 10 <sup>-4</sup> kgm <sup>2</sup>	IM B5 	Mod.	Mb Nm	Zo 1/h	Jm x 10 <sup>-4</sup> kgm <sup>2</sup>	IM B5 	Mod.	Mb Nm	Zo 1/h	Jm x 10 <sup>-4</sup> kgm <sup>2</sup>	IM B5 			
0.20	<b>BN 63B</b>	2	0.71	55	0.82	0.64	3.5	2.1	1.9	2.9	4.4	<b>FD 02</b>	3.5	2200	2600	3.5	6.1	<b>FA 02</b>	3.5	2600	5100	3.5	5.9	<b>BA 60</b>	5	2000	49	6.7	
0.15		4	1.06	49	0.67	0.66	2.6	1.8	1.7	4.7	4.4		4000	5100												4000			
0.28	<b>BN 71A</b>	2	0.99	56	0.82	0.88	2.9	1.9	1.7	4.7	4.4	<b>FD 03</b>	3.5	2100	2400	5.8	7.1	<b>FA 03</b>	3.5	2400	4800	3.5	6.8	<b>BA 70</b>	8	2100	56	8.3	
0.20		4	1.39	59	0.72	0.68	3.1	1.8	1.7	5.8	5.1		3800	4800												4200			
0.37	<b>BN 71B</b>	2	1.29	56	0.82	1.16	3.5	1.8	1.8	5.8	5.1	<b>FD 03</b>	5	1400	2100	6.9	7.8	<b>FA 03</b>	5	2100	4200	5	7.5	<b>BA 70</b>	8	1800	7.8	9.0	
0.25		4	1.72	60	0.73	0.82	3.3	2.0	1.9	6.9	5.9		2900	4200												3600			
0.45	<b>BN 71C</b>	2	1.55	63	0.85	1.21	3.8	1.8	1.8	6.9	5.9	<b>FD 03</b>	5	1400	2100	8.0	8.6	<b>FA 03</b>	5	2100	4200	5	8.3	<b>BA 70</b>	8	1800	8.9	9.8	
0.30		4	2.0	63	0.73	0.94	3.6	2.0	1.9	15	8.2		2900	4200												3600			
0.55	<b>BN 80A</b>	2	1.9	63	0.85	1.48	3.9	1.7	1.7	15	8.2	<b>FD 04</b>	5	1600	2300	16.6	12.1	<b>FA 04</b>	5	2300	4000	5	12.0	<b>BA 80</b>	18	2100	18	13.5	
0.37		4	2.5	67	0.79	1.01	4.1	1.8	1.9	20	9.9		3000	4000												3700			
0.75	<b>BN 80B</b>	2	2.6	65	0.85	1.96	3.8	1.9	1.8	20	9.9	<b>FD 04</b>	10	1400	1600	22	13.8	<b>FA 04</b>	10	1600	3600	10	13.7	<b>BA 80</b>	18	1500	22	15.2	
0.55		4	3.8	68	0.81	1.44	3.9	1.7	1.7	20	9.9		2700	3600												3300			
1.1	<b>BN 90S</b>	2	3.8	71	0.82	2.73	4.7	2.3	2.0	21	12.2	<b>FD 14</b>	10	1500	1600	23	16.4	<b>FA 14</b>	10	1600	2800	10	16.3	<b>BA 90</b>	35	1300	28	19.5	
0.75		4	5.2	66	0.79	2.08	4.6	2.4	2.2	28	14.0		2300	2800												2300			
1.5	<b>BN 90L</b>	2	5.2	70	0.85	3.64	4.5	2.4	2.1	28	14.0	<b>FD 05</b>	26	1050	1200	32	20	<b>FA 05</b>	26	1200	2000	26	21	<b>BA 90</b>	35	1100	35	21	
1.1		4	7.6	73	0.81	2.69	4.7	2.5	2.2	28	14.0		1600	2000												1800			
2.2	<b>BN 100LA</b>	2	7.5	72	0.85	5.2	4.5	2.0	1.9	40	18.3	<b>FD 15</b>	26	600	900	44	25	<b>FA 15</b>	26	900	44	25	25	<b>BA 100</b>	50	750	51	29	
1.5		4	10.2	73	0.79	3.8	4.7	2.0	2.0	40	18.3		1300	2300												1900			
3.5	<b>BN 100LB</b>	2	11.7	80	0.84	7.5	5.4	2.2	2.1	61	25	<b>FD 15</b>	40	500	900	65	31	<b>FA 15</b>	40	900	65	31	32	<b>BA 100</b>	50	750	72	35	
2.5		4	16.8	82	0.80	5.5	5.2	2.2	2.2	61	25		1000	2100												1800			
4	<b>BN 112M</b>	2	13.3	79	0.83	8.8	6.1	2.4	2.0	98	30	<b>FD 06S</b>	60	—	—	107	40	<b>FA 06S</b>	60	700	107	40	42	<b>BA 110</b>	75	600	114	43	
3.3		4	22.2	80	0.80	7.4	5.1	2.1	2.0	98	30		—	—	—	—	—									1100			
5.5	<b>BN 132S</b>	2	18.2	80	0.87	11.4	5.9	2.4	2.0	213	44	<b>FD 56</b>	75	—	—	223	57	<b>FA 06</b>	75	350	223	57	58	<b>BA 140</b>	150	300	263	76	
4.4		4	29	82	0.84	9.2	5.3	2.2	2.0	213	44		—	—	—	—	—									750			
7.5	<b>BN 132MA</b>	2	25	82	0.87	15.2	6.5	2.4	2.0	270	53	<b>FD 06</b>	100	—	—	280	66	<b>FA 07</b>	100	350	293	71	71	<b>BA 140</b>	150	300	320	85	
6		4	40	84	0.85	12.1	5.8	2.3	2.1	270	53		—	—	—	—	—									800			
9.2	<b>BN 132MB</b>	2	30	83	0.86	18.6	6.0	2.6	2.2	319	59	<b>FD 07</b>	150	—	—	342	75	<b>FA 07</b>	150	300	342	77	77	<b>BA 140</b>	150	300	369	91	
7.3		4	48	85	0.85	14.6	5.5	2.3	2.1	319	59		—	—	—	—	—									750			

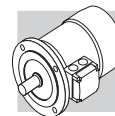

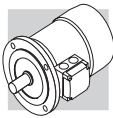
Pn kW		n min <sup>-1</sup>	Mh Nm	η %	cos φ	In [400V] A	Is In	Ms Mn	Ma Mn	Jm x 10 <sup>-4</sup> kgm <sup>2</sup>	IM B5 	freno c.c. / d.c. brake G.S.-bremse / frein c.c.						freno c.a. / a.c. brake W.S.-bremse / frein c.a.					
												FD			FA			BA			FD		
												Mod.	Mb Nm	Z <sub>0</sub> 1/h	IM B5 	Jm x 10 <sup>-4</sup> kgm <sup>2</sup>	Z <sub>0</sub> 1/h	Mod.	Mb max Nm	Z <sub>0</sub> 1/h	Jm x 10 <sup>-4</sup> kgm <sup>2</sup>	IM B5 	
0.25	<b>BN 71A</b>	2	0.84	60	0.82	0.73	4.3	1.9	1.8	6.9	5.9	<b>FD 03</b>	1.75	1500	8.6	8.0	1700	<b>FA 03</b>	<b>BA 70</b>	8	1500	8.9	8.3
0.08		6	0.84	43	0.70	0.38	2.1	1.4	1.5				10000	13000			13000				11000		
0.37	<b>BN 71B</b>	2	1.23	62	0.80	1.08	4.4	1.9	1.8	9.1	7.3	<b>FD 03</b>	3.5	1000	10.0	10.2	1300	<b>FA 03</b>	<b>BA 70</b>	8	1200	11.1	9.7
0.12		6	1.27	44	0.73	0.54	2.4	1.4	1.5				9000	11000			11000				10000		
0.55	<b>BN 80A</b>	2	1.88	63	0.86	1.47	4.5	1.9	1.7	20	9.9	<b>FD 04</b>	5	1500	13.8	22	1800	<b>FA 04</b>	<b>BA 80</b>	18	1700	23	13.7
0.18		6	1.85	52	0.65	0.77	3.3	2	1.9				4100	6300			6300				6000		
0.75	<b>BN 80B</b>	2	2.6	66	0.87	1.89	4.3	1.8	1.6	25	11.3	<b>FD 04</b>	5	1700	15.2	27	1900	<b>FA 04</b>	<b>BA 80</b>	18	1800	28	15.1
0.25		6	2.6	54	0.67	1.00	3.2	1.7	1.8				3800	6000			6000				5600		
1.1	<b>BN 90L</b>	2	3.7	67	0.84	2.82	4.7	2.1	1.9	28	14.0	<b>FD 05</b>	13	1400	20	32	1600	<b>FA 05</b>	<b>BA 90</b>	35	1500	35	21
0.37		6	3.8	59	0.71	1.27	3.3	1.6	1.6				3400	5200			5200				4700		
1.5	<b>BN 100LA</b>	2	5.0	73	0.84	3.53	5.1	1.9	2.0	40	18.3	<b>FD 15</b>	13	1000	24	44	1200	<b>FA 15</b>	<b>BA 100</b>	50	1050	51	25
0.55		6	5.6	64	0.67	1.85	3.5	1.7	1.8				2900	4000			4000				3500		
2.2	<b>BN 100LB</b>	2	7.2	77	0.85	4.9	5.9	2.0	2.0	61	25	<b>FD 15</b>	26	700	31	65	900	<b>FA 15</b>	<b>BA 100</b>	50	800	72	32
0.75		6	7.5	67	0.64	2.5	3.3	1.9	1.8				2100	3000			3000				2700		
3	<b>BN 112M</b>	2	9.9	78	0.87	6.4	6.3	2.0	2.1	98	30	<b>FD 06S</b>	40	—	40	107	1000	<b>FA 06S</b>	<b>BA 110</b>	75	930	114	32
1.1		6	11.1	72	0.64	3.4	3.9	1.8	1.8				—	2600			2600				2400		
4.5	<b>BN 132S</b>	2	14.8	78	0.84	9.9	5.8	1.9	1.8	213	44	<b>FD 56</b>	37	—	57	223	500	<b>FA 06</b>	<b>BA 140</b>	150	400	263	58
1.5		6	14.9	74	0.67	4.4	4.2	1.9	2.0				—	2100			2100				1700		
5.5	<b>BN 132M</b>	2	18.0	78	0.87	11.7	6.2	2.1	1.9	270	53	<b>FD 56</b>	50	—	66	280	400	<b>FA 06</b>	<b>BA 140</b>	150	350	320	67
2.2		6	22	77	0.71	5.8	4.3	2.1	2.0				—	1900			1900				1600		









Pn kW		n min <sup>-1</sup>	Mh Nm	η %	cos φ	In [400V] A	Is In	Ms Mn	Ma Mn	Jm x 10 <sup>-4</sup> kgm <sup>2</sup>	IM B5 	freno c.c. / d.c. brake G.S.-bremse / frein c.c.						freno c.a. / a.c. brake W.S.-bremse / frein c.a.											
												FD			FA			BA			FD			FA			BA		
												Mod.	Mb Nm	Zo 1/h	NB	SB	Jm x 10 <sup>-4</sup> kgm <sup>2</sup>	IM B5 	Mod.	Mb Nm	Zo 1/h	Jm x 10 <sup>-4</sup> kgm <sup>2</sup>	IM B5 	Mod.	Mb Nm	Zo 1/h	Jm x 10 <sup>-4</sup> kgm <sup>2</sup>	IM B5 	
0.25	<b>BN 71A</b>	2	0.86	61	0.87	0.68	3.9	1.8	1.9	10.9	6.7	FD 03	1.75	1300	1400	12	9.4	FA 03	2.5	1400	12	9.1	BA 70	8	1300	12.9	10.6		
0.06		8	0.84	31	0.61	0.46	2	1.8	1.9				10000	13000						13000					12000				
0.37	<b>BN 71B</b>	2	1.26	63	0.86	0.99	3.9	1.8	1.9	12.9	7.7	FD 03	3.5	1200	1300	14	10.4	FA 03	3.5	1300	14	10.1	BA 70	8	1200	14.9	11.6		
0.09		8	1.28	34	0.75	0.51	1.8	1.4	1.5				9500	13000						13000					12000				
0.55	<b>BN 80A</b>	2	1.86	66	0.86	1.40	4.4	2.1	2.0	20	9.9	FD 04	5	1500	1800	22	13.8	FA 04	5	1800	22	13.7	BA 80	18	1700	23	15.2		
0.13		8	1.80	41	0.64	0.72	2.3	1.6	1.7				5600	8000						8000					7500				
0.75	<b>BN 80B</b>	2	2.6	68	0.88	1.81	4.6	2.1	2.0	25	11.3	FD 04	10	1700	1900	27	15.2	FA 04	10	1900	27	15.1	BA 80	18	1800	28	16.6		
0.18		8	2.5	43	0.66	0.92	2.3	1.6	1.7				4800	7300						7300					7000				
1.1	<b>BN 90L</b>	2	3.7	63	0.84	3.00	4.5	2.1	1.9	28	14	FD 05	13	1400	1600	32	20	FA 05	13	1600	32	21	BA 90	35	1400	35	21		
0.28		8	3.9	48	0.63	1.34	2.4	1.8	1.9				3400	5100						5100					4500				
1.5	<b>BN 100LA</b>	2	5.0	69	0.85	3.69	4.7	1.9	1.8	40	18.3	FD 15	13	1000	1200	44	25	FA 15	13	1200	44	25	BA 100	50	1000	52	29		
0.37		8	5.1	46	0.63	1.84	2.1	1.6	1.6				3300	5000						5000					4200				
2.4	<b>BN 100LB</b>	2	7.9	75	0.82	5.6	5.4	2.1	2.0	61	25	FD 15	26	550	700	65	31	FA 15	26	700	65	32	BA 100	50	600	72	36		
0.55		8	7.5	54	0.58	2.5	2.6	1.8	1.8				2000	3500						3500					3100				
3	<b>BN 112M</b>	2	9.9	76	0.87	6.5	6.3	2.1	1.9	98	30	FD 06S	40	—	900	107	40	FA 06S	40	900	107	42	BA 110	75	800	114	43		
0.75		8	10.4	60	0.65	2.8	2.5	1.6	1.6				—	—	2900					2900					2700				
4	<b>BN 132S</b>	2	13.3	73	0.84	9.4	5.6	2.3	2.4	213	44	FD 56	37	—	500	223	57	FA 06	37	500	223	58	BA 140	150	400	263	76		
1		8	13.8	66	0.62	3.5	2.9	1.9	1.8				—	—	3500					3500					3000				
5.5	<b>BN 132M</b>	2	18.3	75	0.84	12.6	6.1	2.4	2.5	270	53	FD 06	50	—	400	280	66	FA 06	50	400	280	67	BA 140	150	350	320	85		
1.5		8	21	68	0.63	5.1	2.9	1.9	1.9				—	—	2400					2400					2100				

# 2/12 P

## 3000/500 min<sup>-1</sup> - S3 60/40%

### 50 Hz

Pn kW		n min <sup>-1</sup>	Mh Nm	η %	cos φ	In [400V] A	Is In	Ms Mn	Ma Mn	Jm x 10 <sup>-4</sup> kgm <sup>2</sup>	IMB5 	freno c.c. / d.c. brake G.S.-bremse / frein c.c.						freno c.a. / a.c. brake W.S.-bremse / frein c.a.											
												FD			FA			BA			FD			FA			BA		
												Mod.	Mb Nm	Zo 1/h NB SB	Jm x 10 <sup>-4</sup> kgm <sup>2</sup>	IMB5 	Mod.	Mb Nm	Zo 1/h	Jm x 10 <sup>-4</sup> kgm <sup>2</sup>	IMB5 	Mod.	Mb Nm	Zo 1/h	Jm x 10 <sup>-4</sup> kgm <sup>2</sup>	IMB5 			
0.55	<b>BN 80B</b>	2 2820	1.86	64	0.89	1.39	4.2	1.6	1.7	25	11.3	<b>FD 04</b>	5	1000	1300	27	15.2	<b>FA 04</b>	5	1300	27	15.1	<b>BA 80</b>	18	1200	28	16.6		
0.09		12 430	2.0	30	0.63	0.69	1.8	1.9	1.8	12000			8000	12000															
0.75	<b>BN 90L</b>	2 2790	2.6	56	0.89	2.17	4.2	1.8	1.7	26	12.6	<b>FD 05</b>	13	1000	1150	30	18.6	<b>FA 05</b>	13	1150	30	19.3	<b>BA 90</b>	35	1050	33	19.9		
0.12		12 430	2.7	26	0.63	1.06	1.7	1.4	1.6	6300			4600	6300															
1.1	<b>BN 100LA</b>	2 2850	3.7	65	0.85	2.87	4.5	1.6	1.8	40	18.3	<b>FD 15</b>	13	700	900	44	25	<b>FA 15</b>	13	900	44	25	<b>BA 100</b>	50	750	52	29		
0.18		12 430	4.0	26	0.54	1.85	1.5	1.3	1.5	6000			4000	6000															
1.5	<b>BN 100LB</b>	2 2900	4.9	67	0.86	3.76	5.6	1.9	1.9	54	22	<b>FD 15</b>	13	700	900	58	28	<b>FA 15</b>	13	900	58	29	<b>BA 100</b>	50	800	66	32		
0.25		12 440	5.4	36	0.46	2.18	1.8	1.7	1.8	5000			3800	5000															
2	<b>BN 112M</b>	2 2900	6.6	74	0.88	4.43	6.5	2.1	2	98	30	<b>FD 06S</b>	20	—	800	107	40	<b>FA 06S</b>	20	800	107	42	<b>BA 110</b>	75	750	114	43		
0.3		12 460	6.2	46	0.43	2.19	2	2.1	2	3400			—	—	3400														
3	<b>BN 132S</b>	2 2920	9.8	74	0.87	6.7	6.8	2.3	1.9	213	44	<b>FD 56</b>	37	—	450	223	57	<b>FA 06</b>	37	450	223	58	<b>BA 140</b>	150	380	263	76		
0.5		12 470	10.2	51	0.43	3.3	2	1.7	1.6	3000			—	—	3000														
4	<b>BN 132M</b>	2 2920	13.1	75	0.89	8.6	5.9	2.4	2.3	270	53	<b>FD 56</b>	37	—	400	280	66	<b>FA 06</b>	37	400	280	67	<b>BA 140</b>	150	350	320	85		
0.7		12 460	14.5	53	0.44	4.3	1.9	1.7	1.6	2800			—	—	2800														

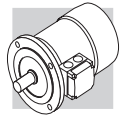

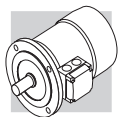







# 4/6 P

## 1500/1000 min<sup>-1</sup> - S1

### 50 Hz

Pn kW		n min <sup>-1</sup>	Mn Nm	η %	cos φ	In [400V] A	Is In	Ms Mn	Ma Mn	Jm x 10 <sup>-4</sup> kgm <sup>2</sup>	IMB5 	freno c.c. / d.c. brake G.S.-bremse / frein c.c.						freno c.a. / a.c. brake W.S.-bremse / frein c.a.											
												FD			FA			BA			FA			BA					
												Mod.	Nm	Zo 1/h	Mod.	Nm	Zo 1/h	Mod.	Nm	Zo 1/h	Mod.	Nm	Zo 1/h	Mod.	Nm	Zo 1/h	Mod.	Nm	Zo 1/h
0.22	<b>BN 71B</b>	4	1.5	64	0.74	0.67	3.9	1.8	1.9	9.1	7.3	IMB5	FD 03	3.5	2500	3500	10.2	10	FA 03	3.5	3500	9000	10.2	9.7	BA 70	8	3200	11.1	11.2
0.13		6	1.4	43	0.67	0.65	2.3	1.6	1.7					5000	9000											8200			
0.30	<b>BN 80A</b>	4	2.0	61	0.82	0.87	3.5	1.3	1.5	15	8.2	IMB5	FD 04	5	2500	3100	16.6	12.1	FA 04	5	3100	6000	16.6	12.0	BA 80	18	2800	18	13.5
0.20		6	2.1	54	0.66	0.81	3.2	1.9	2.0					4000	6000											5500			
0.40	<b>BN 80B</b>	4	2.7	63	0.75	1.22	3.9	1.8	1.8	20	9.9	IMB5	FD 04	10	1800	2300	22	13.8	FA 04	10	2300	5500	22	13.7	BA 80	18	2200	23	15.2
0.26		6	2.7	55	0.70	0.97	2.7	1.5	1.6					3600	5500											5200			
0.55	<b>BN 90S</b>	4	3.7	70	0.78	1.45	4.5	2.0	1.9	21	12.2	IMB5	FD 14	10	1500	2100	23	16.1	FA 14	10	2100	4100	23	16.3	BA 90	35	1700	28	19.5
0.33		6	3.4	62	0.70	1.10	3.7	2.3	2.0					2500	4100											3300			
0.75	<b>BN 90L</b>	4	5.0	74	0.78	1.88	4.3	1.9	1.8	28	14	IMB5	FD 05	13	1400	2000	32	20	FA 05	13	2000	3600	32	21	BA 90	35	1800	35	21
0.45		6	4.7	66	0.71	1.39	3.3	2.0	1.9					2300	3600											3300			
1.1	<b>BN 100LA</b>	4	7.2	74	0.79	2.72	5.0	1.7	1.9	82	22	IMB5	FD 15	26	1400	2000	86	28	FA 15	26	2000	3300	86	29	BA 100	50	1800	94	32
0.8		6	8.0	65	0.69	2.57	4.1	1.9	2.1					2100	3300											3000			
1.5	<b>BN 100LB</b>	4	9.9	75	0.79	3.65	5.1	1.7	1.9	95	25	IMB5	FD 15	26	1300	1800	99	31	FA 15	26	1800	3000	99	32	BA 100	50	1600	107	34
1.1		6	11.1	72	0.68	3.24	4.3	2.0	2.1					2000	3000											2800			
2.3	<b>BN 112M</b>	4	15.2	75	0.78	5.7	5.2	1.8	1.9	168	32	IMB5	FD 06S	40	—	1600	177	42	FA 06S	40	1600	2400	177	44	BA 110	75	1500	184	45
1.5		6	14.9	73	0.72	4.1	4.9	2.0	2.0					—	—	2400										2300			
3.1	<b>BN 132S</b>	4	20	83	0.83	6.5	5.9	2.1	2.0	213	44	IMB5	FD 56	37	—	1200	223	57	FA 06	37	1200	1900	223	58	BA 140	150	1000	263	76
2		6	20	77	0.75	4.9	4.5	2.1	2.1					—	—	1900										1600			
4.2	<b>BN 132MA</b>	4	27	84	0.82	8.8	5.9	2.1	2.2	270	53	IMB5	FD 06	50	—	900	280	66	FA 06	50	900	1500	280	67	BA 140	150	800	320	85
2.6		6	26	79	0.72	6.6	4.3	2.0	2.0					—	—	1500										1300			

**4/8 P****1500/750 min<sup>-1</sup> - S1****50 Hz**

Pn kW		n min <sup>-1</sup>	Mh Nm	η %	cos φ	In [400V] A	Is In	Ms Mn	Ma Mn	Jm x 10 <sup>-4</sup> kgm <sup>2</sup>	IMB5 	freno c.c. / d.c. brake G.S.-bremse / frein c.c.				freno c.a. / a.c. brake W.S.-bremse / frein c.a.																
												FD		FA		BA		FA		BA												
												Mod.	Mb Nm	Zo 1/h	Jm x 10 <sup>-4</sup> kgm <sup>2</sup>	IMB5 	Mod.	Mb Nm	Zo 1/h	Jm x 10 <sup>-4</sup> kgm <sup>2</sup>	IMB5 	Mod.	Mb max Nm	Zo 1/h	Jm x 10 <sup>-4</sup> kgm <sup>2</sup>	IMB5 						
0.37	<b>BN 80A</b>	4	2.5	63	0.82	1.03	3.3	1.4	1.4	15	8.2	10	2300	3500	10	3500	10	3500	16.6	12.0	18	3200	18	3200	16.6	12.0	18	3200	16.6	12.0	18	3200
0.18		8	2.5	44	0.60	0.98	2.2	1.5	1.6	20	9.9	10	4500	7000	10	7000	10	7000	22	13.7	23	6500	23	6500	22	13.7	23	6500	22	13.7	23	6500
0.55	<b>BN 80B</b>	4	3.8	65	0.86	1.42	3.8	1.7	1.6	20	9.9	10	2200	2900	10	2900	10	2900	22	13.7	23	6500	23	6500	22	13.7	23	6500	22	13.7	23	6500
0.30		8	4.3	49	0.65	1.36	2.3	1.7	1.8	28	13.6	15	4200	6500	10	6500	10	6500	30	17.7	35	5100	35	5100	30	17.7	35	5100	30	17.7	35	5100
0.65	<b>BN 90S</b>	4	4.5	73	0.85	1.51	4.0	1.9	1.9	30	15.1	15	2300	2800	15	2800	15	2800	30	17.7	35	5100	35	5100	30	17.7	35	5100	30	17.7	35	5100
0.35		8	4.8	49	0.57	1.81	2.5	2.1	2.2	30	15.1	26	3500	6000	15	6000	15	6000	34	21	37	5100	37	5100	34	21	37	5100	34	21	37	5100
0.9	<b>BN 90L</b>	4	6.3	73	0.87	2.05	3.8	1.8	1.8	30	15.1	26	1700	2100	26	2100	26	2100	34	21	37	5100	37	5100	34	21	37	5100	34	21	37	5100
0.5		8	7.1	57	0.62	2.04	2.4	2.1	2	30	15.1	26	2500	4200	26	4200	26	4200	34	21	37	5100	37	5100	34	21	37	5100	34	21	37	5100
1.3	<b>BN 100LA</b>	4	8.7	72	0.83	3.14	4.3	1.7	1.8	82	22	40	1300	1700	40	1700	40	1700	86	29	94	3100	94	3100	86	29	94	3100	86	29	94	3100
0.7		8	9.6	58	0.64	2.72	2.8	1.8	1.8	82	22	40	2000	3400	40	3400	40	3400	86	29	94	3100	94	3100	86	29	94	3100	86	29	94	3100
1.8	<b>BN 100LB</b>	4	12.1	69	0.87	4.3	4.2	1.6	1.7	95	25	40	1200	1700	40	1700	40	1700	99	31	107	3100	107	3100	99	31	107	3100	99	31	107	3100
0.9		8	12.3	62	0.63	3.3	3.2	1.7	1.8	95	25	40	1600	2600	40	2600	40	2600	99	31	107	3100	107	3100	99	31	107	3100	99	31	107	3100
2.2	<b>BN 112M</b>	4	14.6	77	0.85	4.9	5.3	1.8	1.8	168	32	60	—	—	60	—	60	—	177	42	184	1900	184	1900	177	43	184	1900	177	43	184	1900
1.2		8	16.1	70	0.63	3.9	3.3	1.9	1.8	168	32	60	—	—	60	—	60	—	177	42	184	1900	184	1900	177	43	184	1900	177	43	184	1900
3.6	<b>BN 132S</b>	4	24	80	0.82	7.9	6.5	2.1	1.9	295	45	75	—	—	75	—	75	—	305	58	345	1200	345	1200	305	59	345	1200	305	59	345	1200
1.8		8	24	72	0.55	6.6	4.6	1.9	2	295	45	75	—	—	75	—	75	—	305	58	345	1200	345	1200	305	59	345	1200	305	59	345	1200
4.6	<b>BN 132M</b>	4	30	81	0.83	9.9	6.5	2.2	1.9	383	56	100	—	—	100	—	100	—	393	69	433	1200	433	1200	393	74	433	1200	393	74	433	1200
2.3		8	31	73	0.54	8.4	4.4	2.3	2	383	56	100	—	—	100	—	100	—	393	69	433	1200	433	1200	393	74	433	1200	393	74	433	1200

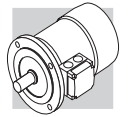

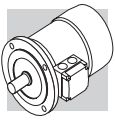

**BN**

**IM B3**

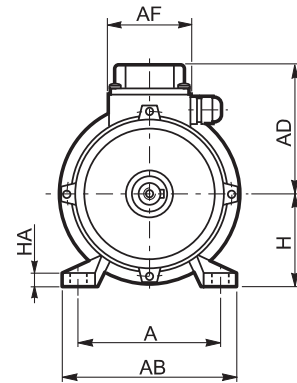
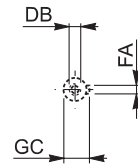
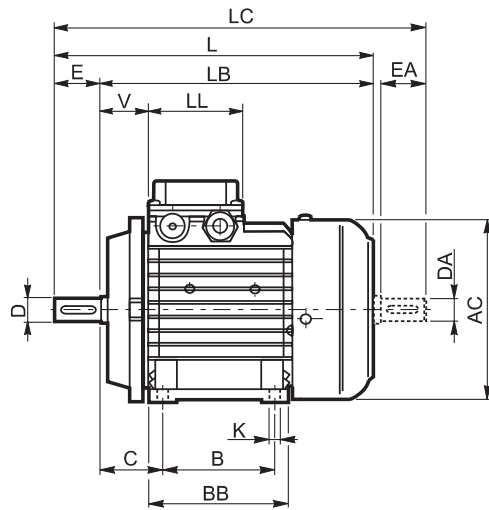
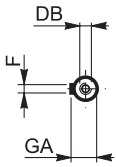

**IM B5**

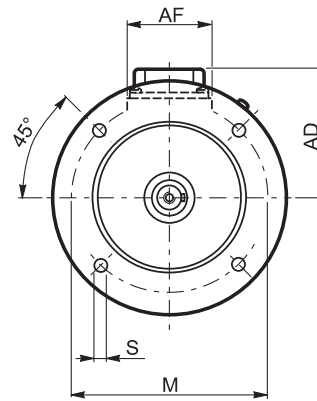
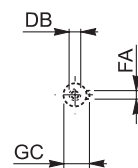
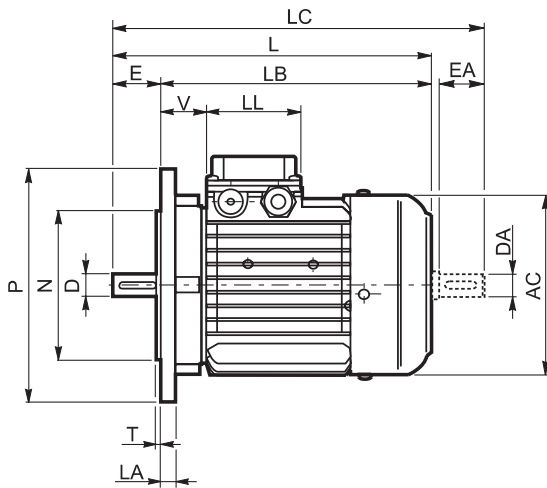
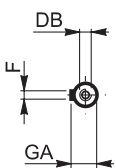

**IM B14**

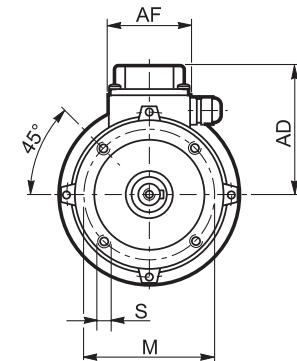
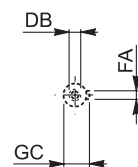
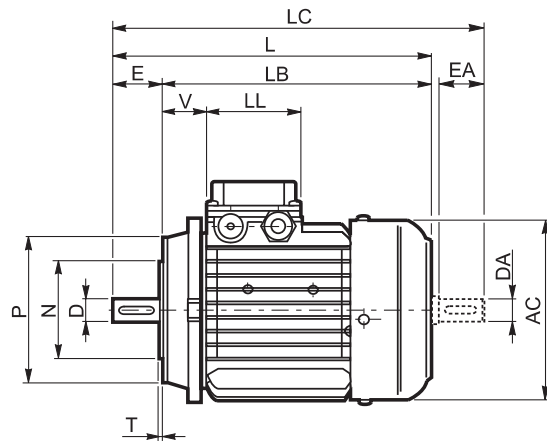
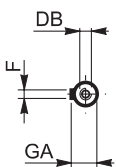

**M29 - DIMENSIONI**
**M29 - DIMENSIONS**
**M29 - ABMESSUNGEN**
**M29 - DIMENSIONS**

<b>BN (IM B3)</b>	Albero / Shaft / Welle / Arbre					Cassa / Frame / Gehäuse / Carcasse						Motore / Motor / Motor / Moteur									
	D DA	E EA	DB	GA GC	F FA	B	A	HA	BB	AB	K	C	H	AC	L	LB	LC	AD	AF	LL	V
BN 63	11	23	M4	12.5	4	80	100	7	96	120	7	40	63	121	212	189	237	92	74	80	30
BN 71	14	30	M5	16	5	90	112	8	112	135	7	45	71	138	249	219	281	105	74	80	35
BN 80	19	40	M6	21.5	6	100	125	9.5	124	153	10	50	80	156	273	233	315	115	74	80	38
BN 90S	24	50	M8	27	8	100	140	13	130	174	10	56	90	176	326	276	379	133	98	98	44
BN 90L	24	50	M8	27	8	125	140	13	155	174	10	56	90	176	326	276	379	133	98	98	44
BN 100	28	60	M10	31	8	140	160	14	175	192	12	63	100	195	367	307	429	142	98	98	50
BN 112	28	60	M10	31	8	140	190	14	175	224	12	70	112	219	385	325	448	157	98	98	52
BN 132S	38	80	M12	41	10	140	216	16	180	260	12	89	132	258	493	413	576	193	118	118	58
BN 132M	38	80	M12	41	10	178	216	16	218	260	12	89	132	258	493	413	576	193	118	118	58

<b>BN (IM B5)</b>	Albero / Shaft / Welle / Arbre					Flangia / Flange / Flansch / Bride						Motore / Motor / Motor / Moteur									
	D DA	E EA	DB	GA GC	F FA	M	N	P	S	T	LA	AC	L	LB	LC	AD	AF	LL	V		
BN 56	9	20	M3	10.2	3	100	80	120	7	3	8	110	185	165	207	91	74	80	34		
BN 63	11	23	M4	12.5	4	115	95	140	9.5	3	10	121	207	184	232	95	74	80	26		
BN 71	14	30	M5	16	5	130	110	160	9.5	3.5	10	138	249	219	281	108	74	80	37		
BN 80	19	40	M6	21.5	6	165	130	200	11.5	3.5	11.5	156	274	234	315	119	74	80	38		
BN 90	24	50	M8	27	8	165	130	200	11.5	3.5	11.5	176	326	276	378	133	98	98	44		
BN 100	28	60	M10	31	8	215	180	250	14	4	14	195	367	307	429	142	98	98	50		
BN 112	28	60	M10	31	8	215	180	250	14	4	15	219	385	325	448	157	98	98	52		
BN 132	38	80	M12	41	10	265	230	300	14	4	20	258	493	413	576	193	118	118	58		
BN 160MR	42 38 <sup>(1)</sup>	110 80 <sup>(1)</sup>	M16 M12 <sup>(1)</sup>	45 41 <sup>(1)</sup>	12 10 <sup>(1)</sup>	300	250	350	18.5	5	15	258	562	452	645	193	118	118	218		
BN 160M	42 38 <sup>(1)</sup>	110 80 <sup>(1)</sup>	M16 M12 <sup>(1)</sup>	45 41 <sup>(1)</sup>	12 10 <sup>(1)</sup>	300	250	350	18.5	5	15	310	596	486	680	245	187	187	51		
BN 160L	42 38 <sup>(1)</sup>	110 80 <sup>(1)</sup>	M16 M12 <sup>(1)</sup>	45 41 <sup>(1)</sup>	12 10 <sup>(1)</sup>	300	250	350	18.5	5	15	310	596	486	680	245	187	187	51		
BN 180M	48 38 <sup>(1)</sup>	110 80 <sup>(1)</sup>	M16 M12 <sup>(1)</sup>	51.5 41 <sup>(1)</sup>	14 10 <sup>(1)</sup>	300	250	350	18.5	5	15	310	640	530	724	245	187	187	51		
BN 180L	48 42 <sup>(1)</sup>	110 110 <sup>(1)</sup>	M16 M16 <sup>(1)</sup>	51.5 45 <sup>(1)</sup>	14 12 <sup>(1)</sup>	300	250	350	18.5	5	18	348	708	598	823	261	187	187	52		
BN 200L	55 42 <sup>(1)</sup>	110 110 <sup>(1)</sup>	M20 M16 <sup>(1)</sup>	59 45 <sup>(1)</sup>	16 12 <sup>(1)</sup>	350	300	400	18.5	5	18	348	722	612	837	261	187	187	66		

<b>BN (IM B14)</b>	Albero / Shaft / Welle / Arbre					Flangia / Flange / Flansch / Bride					Motore / Motor / Motor / Moteur									
	D DA	E EA	DB	GA GC	F FA	M	N	P	S	T	AC	L	LB	LC	AD	AF	LL	V		
BN 56	9	20	M3	10.2	3	65	50	80	M5	2.5	110	185	165	207	91	74	80	34		
BN 63	11	23	M4	12.5	4	75	60	90	M5	2.5	121	207	184	232	95	74	80	26		
BN 71	14	30	M5	16	5	85	70	105	M6	2.5	138	249	219	281	108	74	80	37		
BN 80	19	40	M6	21.5	6	100	80	120	M6	3	156	274	234	315	119	74	80	38		
BN 90	24	50	M8	27	8	115	95	140	M8	3	176	326	276	378	133	98	98	44		
BN 100	28	60	M10	31	8	130	110	160	M8	3.5	195	367	307	429	142	98	98	50		
BN 112	28	60	M10	31	8	130	110	160	M8	3.5	219	385	325	448	157	98	98	52		
BN 132	38	80	M12	41	10	165	130	200	M10	4	258	493	413	576	193	118	118	58		

**N.B.:**

1) Queste dimensioni sono riferite alla seconda estremità d'albero

**NOTE:**

1) These values refer to the rear shaft end.

**HINWEIS:**

1) Diese Maße betreffen das zweite Wellenende.

**REMARQUE :**

1) Ces dimensions se réfèrent à la deuxième extrémité de l'arbre.



# BN\_FD

## IM B3

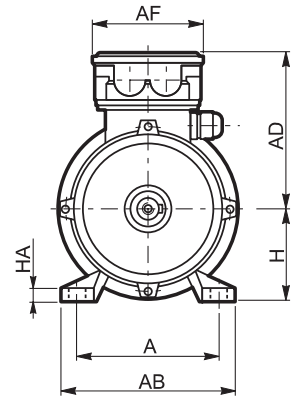
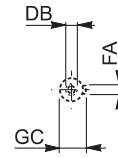
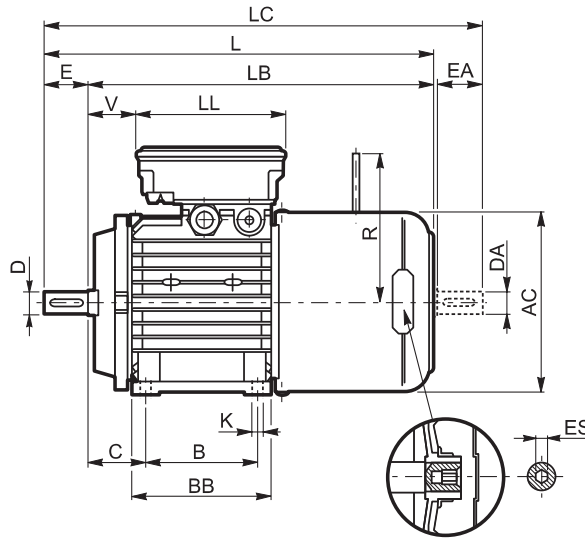
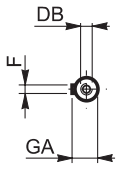

## IM B5

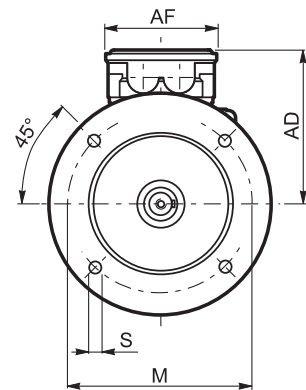
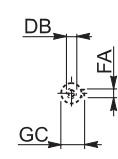
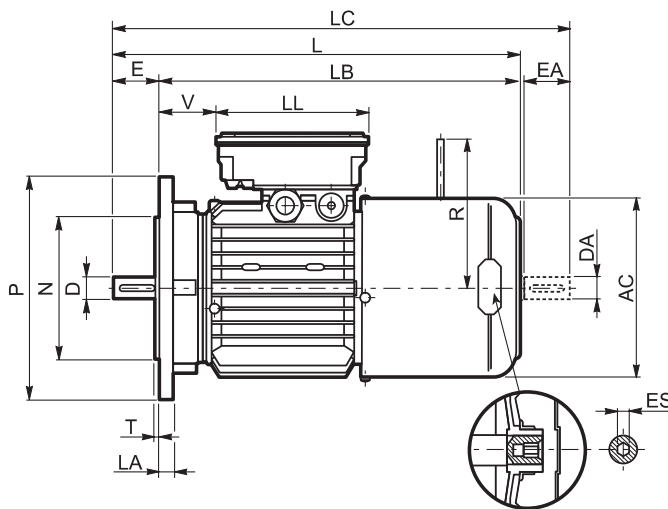
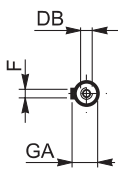

## IM B14

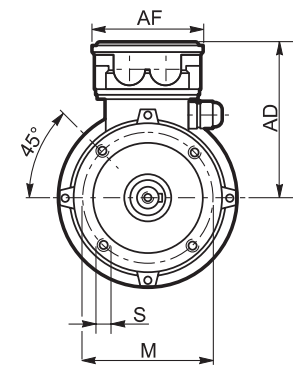
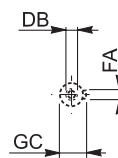
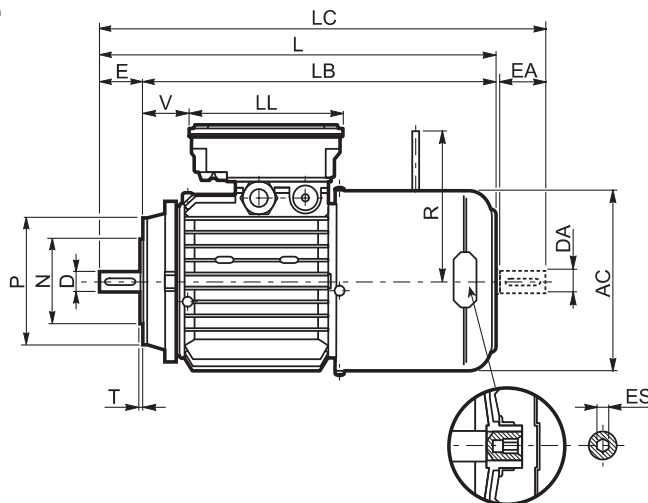
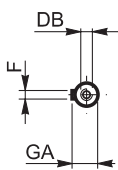





BN_FD (IM B3)	Albero / Shaft / Welle / Arbre					Cassa / Frame / Gehäuse / Carcasse							Motore / Motor / Motor / Moteur										
	D DA	E EA	DB	GA GC	F FA	B	A	HA	BB	AB	K	C	H	AC	L	LB	LC	AD	AF	LL	V	R	ES
BN 63	11	23	M4	12.5	4	80	100	7	96	120	7	40	63	121	269	246	294	122	98	133	51	96	5
BN 71	14	30	M5	16	5	90	112	8	112	135	7	45	71	138	310	280	342	135	98	133	25	103	5
BN 80	19	40	M6	21.5	6	100	125	9.5	124	153	10	50	80	156	346	306	388	146	98	133	41	129	5
BN 90S	24	50	M8	27	8	100	140	13	130	174	10	56	90	176	409	359	461	149	110	165	39	129	6
BN 90L	24	50	M8	27	8	125	140	13	155	174	10	56	90	176	409	359	461	149	110	165	39	160	6
BN 100	28	60	M10	31	8	140	160	14	175	192	12	63	100	195	458	398	521	158	110	165	62	160	6
BN 112	28	60	M10	31	8	140	190	14	175	224	12	70	112	219	484	424	547	173	110	165	73	199	6
BN 132S	38	80	M12	41	10	140	216	16	180	260	12	89	132	258	565	485	648	210	140	188	84	204 <sup>(2)</sup>	6
BN 132M	38	80	M12	41	10	178	216	16	218	260	12	89	132	258	603	523	686	210	140	188	122	204 <sup>(2)</sup>	6

BN_FD (IM B5)	Albero / Shaft / Welle / Arbre					Flangia / Flange / Flansch / Bride						Motore / Motor / Motor / Moteur									
	D DA	E EA	DB	GA GC	F FA	M	N	P	S	T	LA	AC	L	LB	LC	AD	AF	LL	V	R	ES
BN 63	11	23	M4	12.5	4	115	95	140	9.5	3	10	121	272	249	297	122	98	133	14	96	5
BN 71	14	30	M5	16	5	130	110	160	9.5	3.5	10	138	310	280	342	135	98	133	25	103	5
BN 80	19	40	M6	21.5	6	165	130	200	11.5	3.5	11.5	156	346	306	388	146	98	133	41	129	5
BN 90S	24	50	M8	27	8	165	130	200	11.5	3.5	11.5	176	409	359	461	149	110	165	39	129	6
BN 90L	24	50	M8	27	8	165	130	200	11.5	3.5	11.5	176	409	359	461	149	110	165	39	160	6
BN 100	28	60	M10	31	8	215	180	250	14	4	14	195	458	398	521	158	110	165	62	160	6
BN 112	28	60	M10	31	8	215	180	250	14	4	15	219	484	424	547	173	110	165	73	199	6
BN 132	38	80	M12	41	10	265	230	300	14	4	20	258	603	523	686	210	140	188	122	204 <sup>(2)</sup>	6
BN 160MR	42 38 <sup>(1)</sup>	110 80 <sup>(1)</sup>	M16 M12 <sup>(1)</sup>	45 41 <sup>(1)</sup>	12 10 <sup>(1)</sup>	300	250	350	18.5	5	15	258	672	562	755	210	140	188	161	226	6
BN 160M	42 38 <sup>(1)</sup>	110 80 <sup>(1)</sup>	M16 M12 <sup>(1)</sup>	45 41 <sup>(1)</sup>	12 10 <sup>(1)</sup>	300	250	350	18.5	5	15	310	736	626	820	245	187	187	51	266	—
BN 160L	42 38 <sup>(1)</sup>	110 80 <sup>(1)</sup>	M16 M12 <sup>(1)</sup>	45 41 <sup>(1)</sup>	12 10 <sup>(1)</sup>	300	250	350	18.5	5	15	310	736	626	820	245	187	187	51	266	—
BN 180M	48 38 <sup>(1)</sup>	110 80 <sup>(1)</sup>	M16 M12 <sup>(1)</sup>	51.5 41 <sup>(1)</sup>	14 10 <sup>(1)</sup>	300	250	350	18.5	5	15	310	780	670	864	245	187	187	51	266	—
BN 180L	48 42 <sup>(1)</sup>	110 110 <sup>(1)</sup>	M16 M16 <sup>(1)</sup>	51.5 45 <sup>(1)</sup>	14 12 <sup>(1)</sup>	300	250	350	18.5	5	18	348	866	756	981	261	187	187	52	305	—
BN 200L	55 42 <sup>(1)</sup>	110 110 <sup>(1)</sup>	M20 M16 <sup>(1)</sup>	59 45 <sup>(1)</sup>	16 12 <sup>(1)</sup>	350	300	400	18.5	5	18	348	878	768	993	261	187	187	64	305	—

BN_FD (IM B14)	Albero / Shaft / Welle / Arbre					Flangia / Flange / Flansch / Bride					Motore / Motor / Motor / Moteur									
	D DA	E EA	DB	GA GC	F FA	M	N	P	S	T	AC	L	LB	LC	AD	AF	LL	V	R	ES
BN 63	11	23	M4	12.5	4	75	60	90	M5	2.5	121	272	249	297	122	98	133	14	96	5
BN 71	14	30	M5	16	5	85	70	105	M6	2.5	138	310	280	342	135	98	133	25	103	5
BN 80	19	40	M6	21.5	6	100	80	120	M6	3	156	346	306	388	146	98	133	41	129	5
BN 90S	24	50	M8	27	8	115	95	140	M8	3	176	409	359	461	149	110	165	39	129	6
BN 90L	24	50	M8	27	8	115	95	140	M8	3	176	409	359	461	149	110	165	39	160	6
BN 100	28	60	M10	31	8	130	110	160	M8	3.5	195	458	398	521	158	110	165	62	160	6
BN 112	28	60	M10	31	8	130	110	160	M8	3.5	219	484	424	547	173	110	165	73	199	6
BN 132	38	80	M12	41	10	165	130	200	M10	4	258	603	523	686	210	140	188	122	204 <sup>(2)</sup>	6

N.B.:

1) Queste dimensioni sono riferite alla seconda estremità d'albero.

2) Per freno FD07 quota R=226

L'esagono ES non è presente con l'opzione PS

NOTE:

1) These values refer to the rear shaft end.

2) For FD07 brake value R=226

ES hexagon is not supplied with PS option

HINWEIS:

1) Diese Maße betreffen das zweite Wellenende

2) Für Bremse FD07, Maß R=226

Der Sechskant ES ist bei der Option PS nicht vorhanden.

REMARQUE :

1) Ces dimensions se réfèrent à la deuxième extrémité de l'arbre

2) Pour frein FD07 valeur R=226

L'hexagone ES n'est pas disponible avec l'option PS

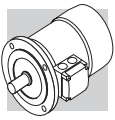

# BN\_FA

## IM B3

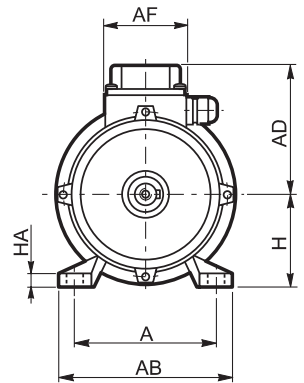
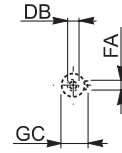
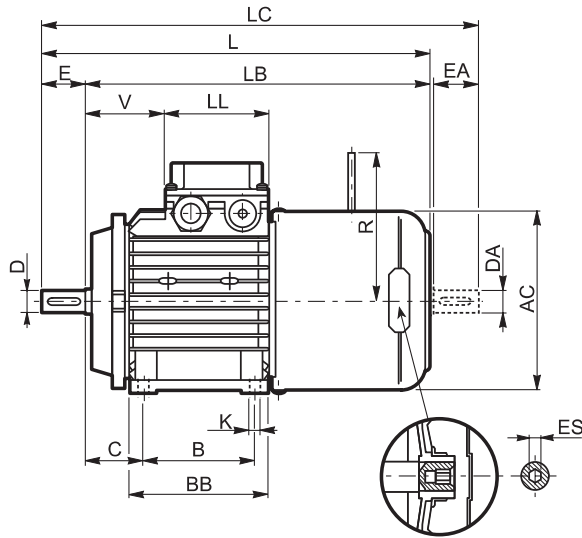
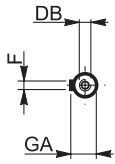

## IM B5

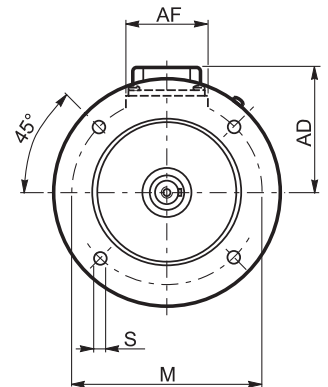
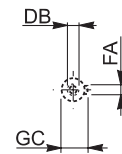
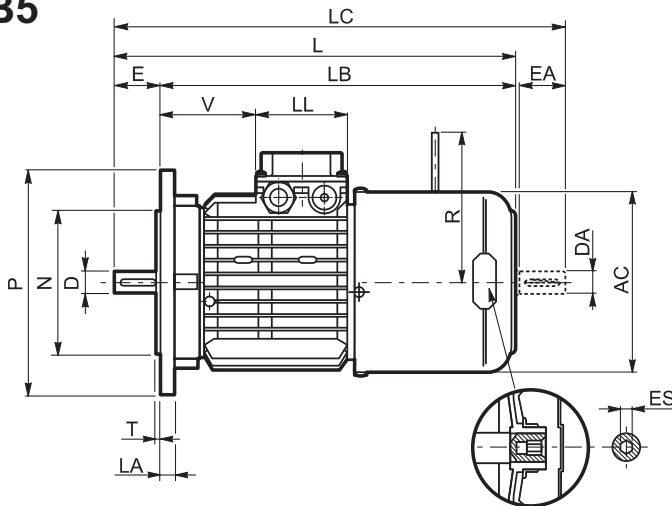
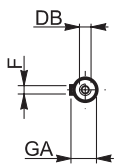

## IM B14

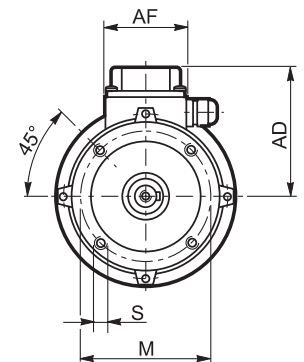
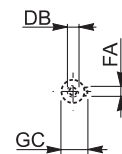
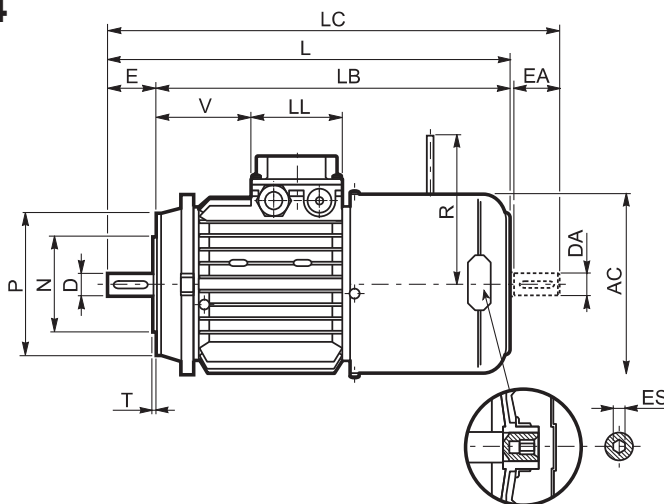
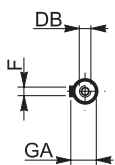



BN_FA (IM B3)	Albero / Shaft / Welle / Arbre					Cassa / Frame / Gehäuse / Carcasse						Motore / Motor / Motor / Moteur											
	D DA	E EA	DB	GA GC	F FA	B	A	HA	BB	AB	K	C	H	AC	L	LB	LC	AD	AF	LL	V	R	ES
BN 63	11	23	M4	12.5	4	80	100	7	96	120	7	40	63	121	269	246	294	92	74	80	51	116	5
BN 71	14	30	M5	16	5	90	112	8	112	135	7	45	71	138	310	280	342	105	74	80	68	124	5
BN 80	19	40	M6	21.5	6	100	125	9.5	124	153	10	50	80	156	346	306	388	115	74	80	83	134	5
BN 90S	24	50	M8	27	8	100	140	13	130	174	10	56	90	176	409	359	461	133	98	98	71	134	6
BN 90L	24	50	M8	27	8	125	140	13	155	174	10	56	90	176	409	359	461	133	98	98	95	160	6
BN 100	28	60	M10	31	8	140	160	14	175	192	12	63	100	195	458	398	521	142	98	98	119	160	6
BN 112	28	60	M10	31	8	140	190	14	175	224	12	70	112	219	484	424	547	157	98	98	142	198	6
BN 132S	38	80	M12	41	10	140	216	16	180	260	12	89	132	258	565	485	648	193	118	118	180	200 <sup>(2)</sup>	6
BN 132M	38	80	M12	41	10	178	216	16	218	260	12	89	132	258	603	523	686	193	118	118	180	200 <sup>(2)</sup>	6

BN_FA (IM B5)	Albero / Shaft / Welle / Arbre					Flangia / Flange / Flansch / Bride						Motore / Motor / Motor / Moteur									
	D DA	E EA	DB	GA GC	F FA	M	N	P	S	T	LA	AC	L	LB	LC	AD	AF	LL	V	R	ES
BN 63	11	23	M4	12.5	4	115	95	140	9.5	3	10	121	272	249	297	95	74	80	26	116	5
BN 71	14	30	M5	16	5	130	110	160	9.5	3.5	10	138	310	280	342	108	74	80	68	124	5
BN 80	19	40	M6	21.5	6	165	130	200	11.5	3.5	11.5	156	346	306	388	119	74	80	83	134	5
BN 90	24	50	M8	27	8	165	130	200	11.5	3.5	11.5	176	409	359	461	133	98	98	95	160	6
BN 100	28	60	M10	31	8	215	180	250	14	4	14	195	458	398	521	142	98	98	119	160	6
BN 112	28	60	M10	31	8	215	180	250	14	4	15	219	484	424	547	157	98	98	128	198	6
BN 132	38	80	M12	41	10	265	230	300	14	4	20	258	603	523	686	193	118	118	180	200 <sup>(2)</sup>	6
BN 160MR	42 38 <sup>(1)</sup>	110 80 <sup>(1)</sup>	M16 M12 <sup>(1)</sup>	45 41 <sup>(1)</sup>	12 10 <sup>(1)</sup>	300	250	350	18.5	5	15	258	672	562	755	193	118	118	218	217	6
BN 160M	42 38 <sup>(1)</sup>	110 80 <sup>(1)</sup>	M16 M12 <sup>(1)</sup>	45 41 <sup>(1)</sup>	12 10 <sup>(1)</sup>	300	250	350	18.5	5	15	310	736	626	820	245	187	187	51	247	—
BN 160L	42 38 <sup>(1)</sup>	110 80 <sup>(1)</sup>	M16 M12 <sup>(1)</sup>	45 41 <sup>(1)</sup>	12 10 <sup>(1)</sup>	300	250	350	18.5	5	15	310	736	626	820	245	187	187	51	247	—
BN 180M	48 38 <sup>(1)</sup>	110 80 <sup>(1)</sup>	M16 M12 <sup>(1)</sup>	51.5 41 <sup>(1)</sup>	14 10 <sup>(1)</sup>	300	250	350	18.5	5	15	310	780	670	864	245	187	187	51	247	—

BN_FA (IM B14)	Albero / Shaft / Welle / Arbre					Flangia / Flange / Flansch / Bride					Motore / Motor / Motor / Moteur									
	D DA	E EA	DB	GA GC	F FA	M	N	P	S	T	AC	L	LB	LC	AD	AF	LL	V	R	ES
BN 63	11	23	M4	12.5	4	75	60	90	M5	2.5	121	272	249	119	95	74	80	26	116	5
BN 71	14	30	M5	16	5	85	70	105	M6	2.5	138	310	280	342	108	74	80	68	124	5
BN 80	19	40	M6	21.5	6	100	80	120	M6	3	156	346	306	388	119	74	80	83	134	5
BN 90	24	50	M8	27	8	115	95	140	M8	3	176	409	359	461	133	98	98	95	160	6
BN 100	28	60	M10	31	8	130	110	160	M8	3.5	195	458	398	521	142	98	98	119	160	6
BN 112	28	60	M10	31	8	130	110	160	M8	3.5	219	484	424	547	157	98	98	128	198	6
BN 132	38	80	M12	41	10	165	130	200	M10	4	258	603	523	686	193	118	118	180	200 <sup>(2)</sup>	6

N.B.:

1) Queste dimensioni sono riferite alla seconda estremità d'albero.

2) Per freno FA07 quota R=217 Le dimensioni AD, AF, LL e V relative alla scatola morsettiera dei motori BN...FA dotati di alimentazione separata del freno (opzione SA) coincidono con quelle dei motori BN...FD di pari taglia.

L'esagono ES non è presente con l'opzione PS.

NOTE:

1) These values refer to the rear shaft end.

2) For FA07 brake value R=217 FDimensions AD, AF, LL and V, relevant to terminal box of motors BN...FA featuring the separate brake supply (option SA), are coincident with corresponding dimensions of same-size BN...FD motors.

ES hexagon is not supplied with PS option.

HINWEIS:

1) Diese Maße betreffen das zweite Wellenende

2) Für Bremse FA07, Maß R=217 Die Abmessungen des Klemmenkastens der Motoren BN ... FA AD, AF, LL und V in bezug auf die separate Spannungsversorgung (Option SA) stimmen mit den Abmessungen der entsprechenden Motoren BN...FD überein.

Der Sechskant ES ist bei Option PS nicht vorhanden.

REMARQUE :

1) Ces dimensions se réfèrent à la deuxième extrémité de l'arbre

2) Pour frein FA07 valeur R=217 Les dimensions AD, AF, LL et V relatives à la boîte à borne des moteurs BN...FA équipés d'alimentation séparée du frein (option SA) sont identiques à celles des moteurs BN...FD de la même taille.

L'hexagone ES n'est pas disponible avec l'option PS.



# BN\_BA

## IM B3

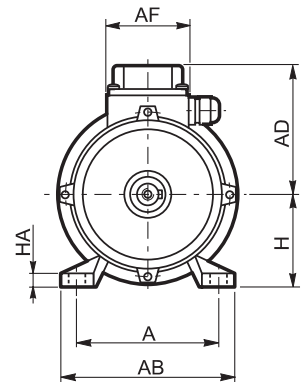
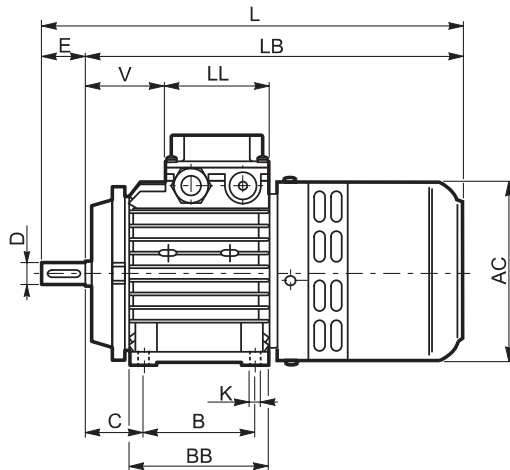
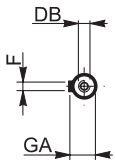

## IM B5

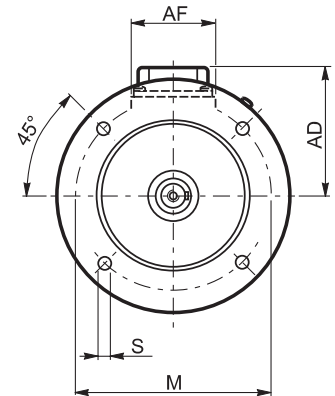
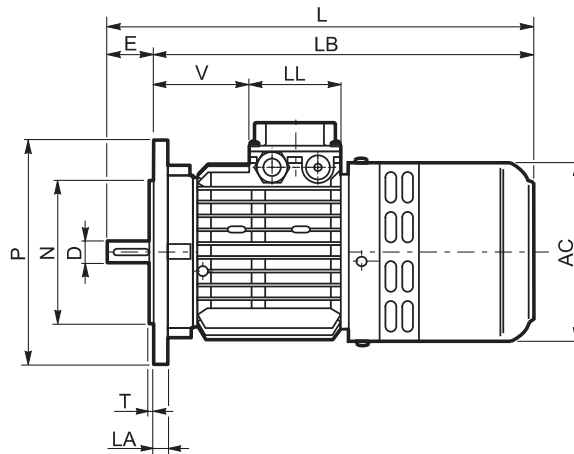
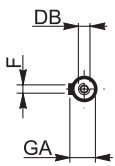

## IM B14

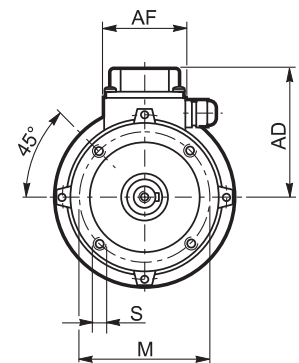
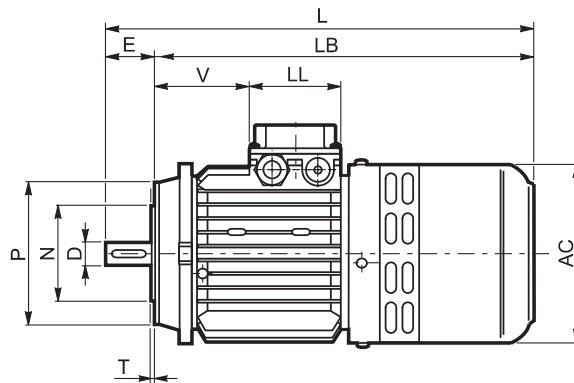
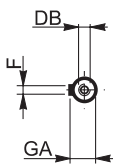

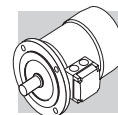

BN_BA (IM B3)	Albero / Shaft / Welle / Arbre					Cassa / Frame / Gehäuse / Carcasse						Motore / Motor / Motor / Moteur									
	D DA	E EA	DB	GA GC	F FA	B	A	HA	BB	AB	K	C	H	AC	L	LB	LC	AD	AF	LL	V
BN 71	14	30	M5	16	5	90	112	8	112	135	7	45	71	138	327	298	342	108	74	80	68
BN 80	19	40	M6	21.5	6	100	125	9.5	124	153	10	50	80	156	372	332	388	119	74	80	83
BN 90S	24	50	M8	27	8	100	140	13	130	174	10	56	90	176	425	375	461	133	98	98	95
BN 90L	24	50	M8	27	8	125	140	13	155	174	10	56	90	176	425	375	461	133	98	98	95
BN 100	28	60	M10	31	8	140	160	14	175	192	12	63	100	195	477	417	521	142	98	98	119
BN 112	28	60	M10	31	8	140	190	14	175	224	12	70	112	219	500	440	547	157	98	98	128
BN 132S	38	80	M12	41	10	140	216	16	180	260	12	89	132	258	600	520	648	193	118	118	142
BN 132M	38	80	M12	41	10	178	216	16	218	260	12	89	132	258	638	558	686	193	118	118	180

BN_BA (IM B5)	Albero / Shaft / Welle / Arbre					Flangia / Flange / Flansch / Bride						Motore / Motor / Motor / Moteur							
	D DA	E EA	DB	GA GC	F FA	M	N	P	S	T	LA	AC	L	LB	AD	AF	LL	V	
BN63	11	23	M4	12.5	4	115	95	140	9.5	3	10	124	298	275	95	74	80	28	
BN 71	14	30	M5	16	5	130	110	160	9.5	3.5	10	138	327	297	108	74	80	68	
BN 80	19	40	M6	21.5	6	165	130	200	11.5	3.5	11.5	156	372	332	119	74	80	83	
BN 90	24	50	M8	27	8	165	130	200	11.5	3.5	11.5	176	425	375	133	98	98	95	
BN 100	28	60	M10	31	8	215	180	250	14	4	14	195	477	417	142	98	98	119	
BN 112	28	60	M10	31	8	215	180	250	14	4	15	219	500	440	157	98	98	128	
BN 132	38	80	M12	41	10	265	230	300	14	4	20	258	638	558	193	118	118	180	

BN_BA (IM B14)	Albero / Shaft / Welle / Arbre					Flangia / Flange / Flansch / Bride					Motore / Motor / Motor / Moteur							
	D DA	E EA	DB	GA GC	F FA	M	N	P	S	T	AC	L	LB	AD	AF	LL	V	
BN 63	11	23	M4	12.5	4	75	60	90	M5	2.5	124	298	275	95	74	80	28	
BN 71	14	30	M5	16	5	85	70	105	M6	2.5	138	327	297	108	74	80	68	
BN 80	19	40	M6	21.5	6	100	80	120	M6	3	156	372	332	119	74	80	83	
BN 90	24	50	M8	27	8	115	95	140	M8	3	176	425	375	133	98	98	95	
BN 100	28	60	M10	31	8	130	110	160	M8	3.5	195	477	417	142	98	98	119	
BN 112	28	60	M10	31	8	130	110	160	M8	3.5	219	500	440	157	98	98	128	
BN 132	38	80	M12	41	10	165	130	200	M10	4	258	638	558	193	118	118	180	

N.B.:

Le dimensioni AD, AF, LL e V relative alla scatola morsettiera dei motori BN...BA dotati di alimentazione separata del freno (opzione SA) coincidono con quelle dei motori BN...FD di pari taglia.

NOTE:

*Dimensions AD, AF, LL and V, relevant to terminal box of motors BN...BA featuring the separate brake supply (option SA), are coincident with corresponding dimensions of same-size BN...FD motors*

HINWEIS:

Die Abmessungen des Klemmenkastens der Motoren BN ... BA AD, AF, LL und V in bezug auf die separate Spannungsversorgung (Option SA) stimmen mit den Abmessungen der entsprechenden Motoren BN...FD überein.

REMARQUE :

*Les dimensions AD, AF, LL et V relatives à la boîte à borne des moteurs BN...BA équipés d'alimentation séparée du frein (option SA) sont identiques à celles des moteurs BN...FD de la même taille.*



# U1

## BN, BN\_FD, BN\_FA

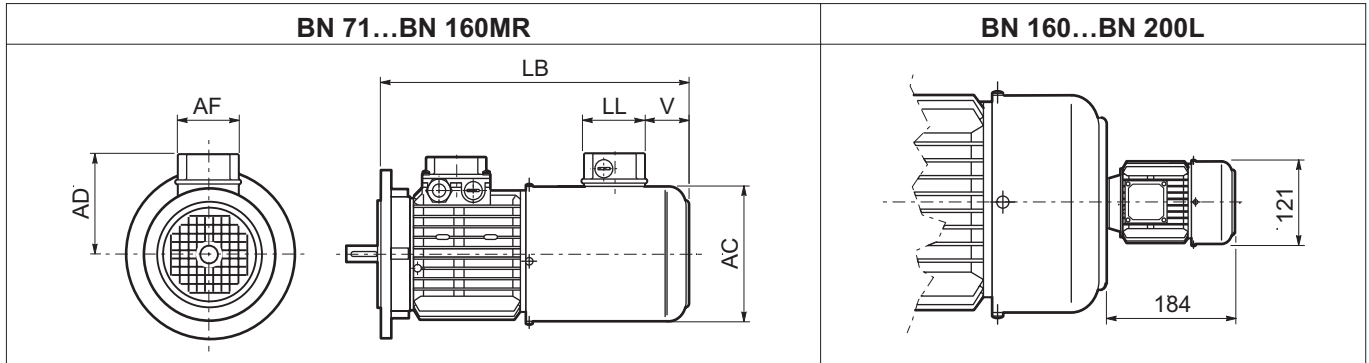

	LB	AC	AD	AF	LL	V
BN 71	312	138	112	70	70	36
BN 80	361	156	120	70	70	40
BN 90	407	176	131	70	70	45
BN 100	426	195	145	90	90	40
BN 112	455	219	155	70	70	55
BN 132	574	258	174	70	70	87
BN 160MR	613	258	174	70	70	87

# U2

## BN, BN\_FD, BN\_FA

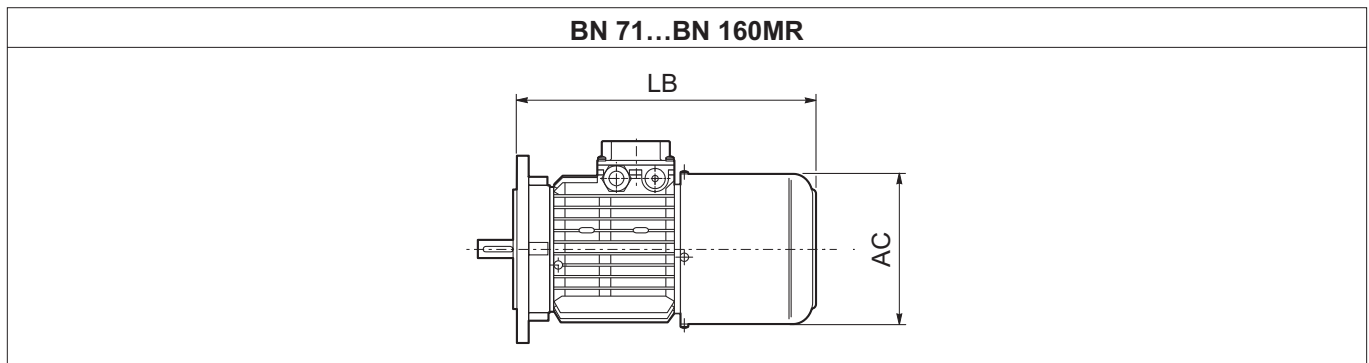

	LB	AC
BN 71	312	138
BN 80	361	156
BN 90	407	176
BN 100	426	195
BN 112	455	219
BN 132	574	258
BN 160MR	613	258

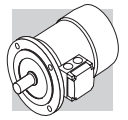



R00_0				
	Descrizione	Description	Beschreibung	Description
32	Corretto dimensioni per V 0.25_SCT ... V 2_SCT.	Corrected dimensions for V 0.25_SCT ... V 2_SCT.	Korrigierte Abmessungen für V 0.25_SCT ... V 2_SCT.	Corrigées dimensions pour V 0.25_SCT ... V 2_SCT.

Questa pubblicazione annulla e sostituisce ogni precedente edizione o revisione. Ci riserviamo il diritto di apportare modifiche senza preavviso. È vietata la produzione anche parziale senza autorizzazione.

*This publication supersedes and replaces any previous edition and revision. We reserve the right to implement modifications without notice. This catalogue cannot be reproduced, even partially, without prior consent.*

Diese Veröffentlichung annulliert und ersetzt jeder hergehende Edition oder Revision. BONFIGLIOLI behält sich das Recht vor, Änderungen ohne vorherige Informationen durchzuführen.

*Cette publication annule et remplace toutes les autres précédentes. Nous nous réservons le droit d'apporter toutes modifications à nos produits. La reproduction et la publication partielle ou totale de ce catalogue est interdite sans notre autorisation.*







Dal 1956 Bonfiglioli progetta e realizza soluzioni innovative ed affidabili per il controllo e la trasmissione di potenza nell'industria e nelle macchine operatrici semoventi e per le energie rinnovabili.

Bonfiglioli has been designing and developing innovative and reliable power transmission and control solutions for industry, mobile machinery and renewable energy applications since 1956.

Seit 1956 plant und realisiert Bonfiglioli innovative und zuverlässige Lösungen für die Leistungsüberwachung und -übertragung in industrieller Umgebung und für selbstfahrende Maschinen sowie Anlagen im Rahmen der erneuerbaren Energien.

Depuis 1956, Bonfiglioli conçoit et réalise des solutions innovantes et fiables pour le contrôle et la transmission de puissance dans l'industrie et dans les machines automotrices et pour les énergies renouvelables.

