

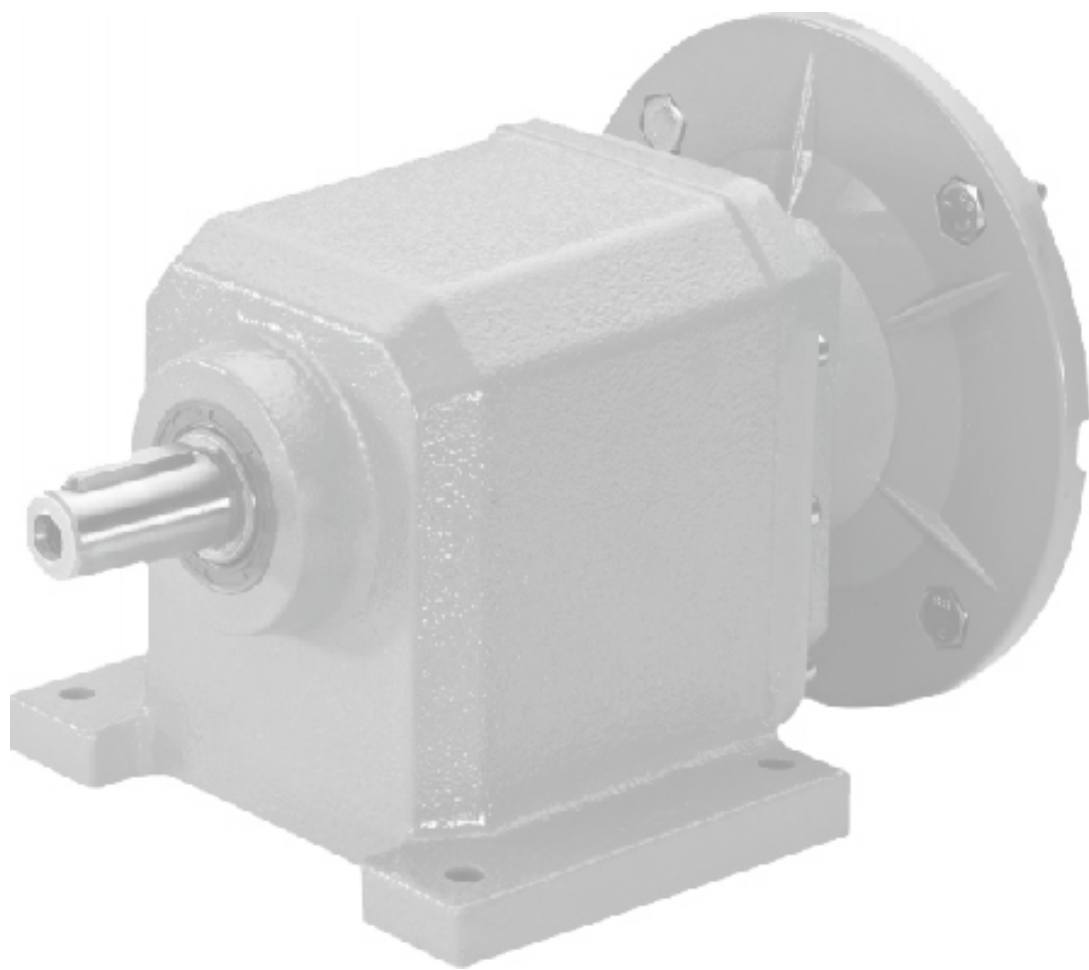

FH Series Helical Inline Geared Motor



CONTENTS

HELICAL	FH SERIES		Page No.
1. Summarize			3
2. Product Structure Picture			3
3. Model Designation			
Gearbox Model Designation			4
Geared Motor Model Designation			5
4. Relevant Parameter			6
5. Service Factor			6
6. Mass Acceleration Factor			7
7. Load Classification			8
8. Radial Loads			9
9. Possible Assembling			10
10. Mounting Positions			12
11. Lubrication			13
12. Symbols and Units Of Measure			13
13. Helical Gear Unit Selection Table			14
14. Outline Dimensions			44

1. SUMMARIZE

FH Helical Gear Box / Geared Motor series is a range of inline gear units which is a next generation mechano-electrical integrated product, designed based on the compact modular system. The FH series Helical Gear units are well known to be the unmatched range of helical geared motors and speed reducers as it is capable of exhibiting optimum torque density, product range, price effectiveness and gear compactness.

FH series Helical Gear units can be connected with wide variety of motors such as normal motor, brake motor, IEC motor and etc., This kind of product is widely used in drive fields such as textile, food processing units, beverage, chemical industry, material handling equipments, automobile, metallurgy, pharma, environment- protection, logistics and many more.

Product development is assured by qualified professionals using latest design software / systems / tools.

Significant production flexibility guarantees a rapid flow of components with high level quality with the usage of state of art machineries and equipments.

We have In-house well equipped testing facilities for quality check & development aimed to ensure effective performances.

1.1 Product Features:

- High durability and reliability
- Effective space utility, refined design
- High torque
- Quite and noiseless operation
- Accepts standard IEC motors
- Versatile mounting
- Wide range of ratios
- Gears from hardened and case-hardened steel
- Mechanical rating - 0.12KW to 15KW
- Powder coated blue colour grade of RAL 5015

2. PRODUCT STRUCTURE PICTURE



FH-F- - - IEC

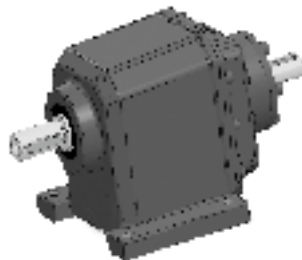

FH-F- - - ISS

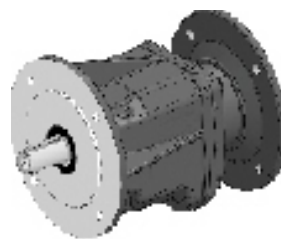

FH-FL- - - IEC





FH-FL- - - ISS

3. MODEL DESIGNATION

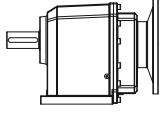
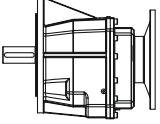
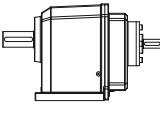
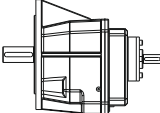
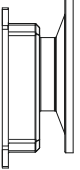
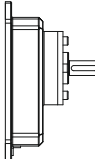
3.1 GEARBOX MODEL DESIGNATION

FH	25	2	F	14	F80	B5	B3
GEAR BOX TYPE	GEAR BOX FRAME	NO.OF REDUCTION	MOUNTING	RATIO	GEARBOX INPUT FRAME SIZE	GEAR BOX INPUT FLANGE CONFIGURATION	GEAR BOX MOUNTING POSITION
	20 (or) 25 (or) 30 (or) 35 (or) 50	2 (or) 3	F- FOOT  (or) FL-FLANGE 		F63 (or) F71 (or) F80 (or) F90 (or) F100 (or) F112 (or) F132 (or) F160 (or) ISS (INPUT SOLID SHAFT)  	B5  (or) NA - (NOT APPLICABLE) 	B3 (or) B6 (or) B7 (or) B8 (or) V5 (or) V6 (or) B5 (or) V1 (or) V3

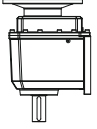
3.2 GEARED MOTOR MODEL DESIGNATION

FH	25	2	F	14	F80	B5	B3	FM 63 A	4	B5	DCB	SPL. OPTIONS
GEAR BOX TYPE	GEAR BOX FRAME	NO.OF REDUCTION	MOUNTING F- FOOT  (or) FL-FLANGE 	RATIO	GEARBOX INPUT FRAME SIZE F63 (or) F71 (or) F80 (or) F90 (or) F100 (or) F12	GEAR BOX INPUT FLANGE CONFIGURATION ONLY B5	GEAR BOX MOUNTING POSITION B3 (or) B6 (or) B7 (or) B8 (or) V5 (or) V6 (or) B5 (or) V1 (or) V3	MOTOR SIZE FM 63 A (or) FM 63 B (or) FM 71 A (or) FM 71 B (or) FM 80 A (or) FM 80 B (or) FM 90 S (or) FM 90 L (or) FM 100 L (or) FM 112 M	NUMBER OF POLES 2 (or) 4 (or) 6	MOUNTING B5- FLANGE (or) B3/B5 FOOT WITH B5 FLANGE	DC BRAKE 190 DC VOLTS WITH RELEASE LEVER	OPTION - 1 TB1 (or) TB2 (or) TB3 (or) TB4 OPTION -3 N-ES OPTION -4 FC

4. RELEVANT PARAMETER

4.1 Power P

$$P_1 = \frac{P_2}{\eta} \text{ [kW]}$$

$$P_{1n} \geq P_1 \cdot f_s \text{ [kW]}$$

P_1 Input power

P_2 Output power

P_{1n} Rated input motor power

f_s Service factor

η Transmission efficiency

The parameter can be found in the FH/ISS gearbox rating charts and represents the KW that can be safely transmitted to the gearbox, based on input speed n_1 and service factor $f_s=1$.

4.2 Rotation speed n

n_1 Gear units input speed

n_2 Gear units output speed

If driven by the external gearing, 1400r/min or lower rotation speed is suggested so as to optimize the working conditions and prolong the service life.

4.3 Transmission ratio i

$$i = \frac{n_1}{n_2}$$

4.4 Torque M

$$M_2 = \frac{9550 \cdot P_1 \cdot \eta}{n_2} \text{ [Nm]}$$

$$M_{2n} \geq M_2 \times f_s \text{ [Nm]}$$

M_2 Output torque

M_{2n} Rated output torque

P_1 Input power

η Transmission efficiency

f_s Service factor

5. SERVICE FACTOR f_s

The effect of the driven machine on the gear unit is taken into account to a sufficient level of accuracy using the service factor f_s . The service factor is determined according to the daily operating time and the starting frequency Z . Three load classifications are considered depending on the mass acceleration factor. You can read the service factor applicable to your application in following figure. The service factor selected using this diagram must be less than or equal to the service factor as given in the performance parameter table.

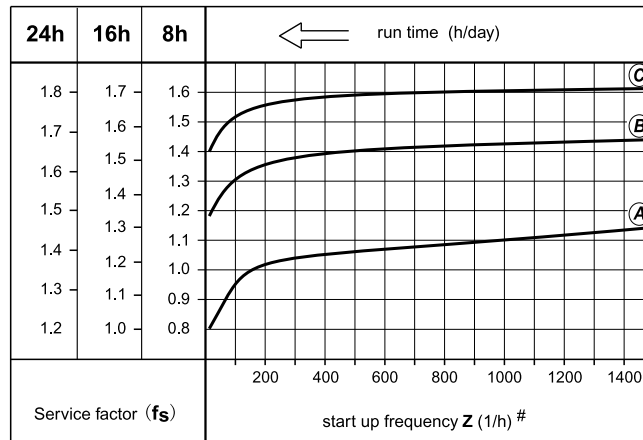

Starting frequency Z: The cycles include all starting and braking procedures as well as change overs from low to high speed.

Type of load:

- (A) Uniform, permitted mass acceleration factor $f_a \leq 0.25$
- (B) Moderate shock load, permitted mass acceleration factor $f_a \leq 3$
- (C) Heavy shock load, permitted mass acceleration factor $f_a \leq 10$

6. MASS ACCELERATION FACTOR

The mass acceleration factor is calculated as follows:

$$f_a = \frac{J_c}{J_m}$$

fa Mass acceleration factor

Jc All external mass moments of inertia [kgm^2]

Jm Mass moment of inertia on the motor end [kgm^2]

If mass acceleration factors $f_a > 10$, please call our Technical Service.

Service factor f_s should be adjusted as followings:

- 1) Ambient temperature is 30 ~ 40°C: $f_s \times (1.1 \sim 1.2)$
- 2) Ambient temperature is 40 ~ 50°C: $f_s \times (1.3 \sim 1.4)$
- 3) Ambient temperature is 50 ~ 60°C: $f_s \times (1.5 \sim 1.6)$
- 4) Ambient temperature >60°C, Please call our Technical Service.

7. LOAD CLASSIFICATION

U = Uniform load M = Medium shock load H = Heavy shock load

* = Only on the basis of 24 hrs service

** = Load can be exactly classified, for instance,

Load classification symbols listed acc. to applications and industries		
Building machinery	Cranes **	Rolls
M Hoists	M Derricking jib gears	M Chain transfers *
M Road construction machinery	H Hoisting gears	H Cold rolling mills *
	M Slewing gears	H Continuous casting plants *
Cement industry	H Travelling gears	M Cooling beds *
H Ball mills *		M Cross transfers *
H Beater mills *	Dredgers	H Descaling machines *
H Breakers	H Bucket conveyors	H Ingot handling machinery *
H Brick presses	H Bucket wheels	H Manipulators *
M Concrete mixers	H Cutter heads	H Reversing plate mills *
H Hammer mills *	M Manoeuvring winches	H Reversing sheet mills *
H Rotary kilns *	M Slewing gears	H Reversing slabbing mills *
	H Travelling gears (caterpillar)	
H Tube mills *	M Travelling gears (rails)	M Roll adjustment drives
		H Tube welding machines *
Centrifugal compressors		M Winding machines (strip and wire) *
M Centrifugal compressors	Food industry machinery	M Wire drawing benches
	U Bottling and container filling machines	Shears
Chemical industry	M Kneading machines	H Billet shears *
U Agitators (liquid material)	M Mash tubs, crystallizers	H Cropping shears *
M Agitators (semi-liquid material)	U Packaging machines	H Plate shears *
M Calenders *	Beet sugar production	M Trimming shears *
M Centrifuges (heavy)	M Sugar beet cutters	
	M Sugar beet washing machines	
U Centrifuges (light)		Oil industry
M Cooling drums *	Cane sugar production	M Pipeline pumps *
M Crushers	M Cane crushers *	H Rotary drilling equipment
H Dough mills *	M Cane knives *	
M Drying drums *	M Cane mills *	Paper machines
H Extruders *		H Paper machines of all kind *
M Mixers	Frequency converters	
H Rolling mills *	H Frequency converters	Piston compressors
	H Generators	H Piston compressors
Conveyors	H Welding generators	
M Apron conveyors		Textile machines
M Ballast elevators	Laundries	M Batches
M Band pocket conveyors	M Tumblers	M Looms
M Belt conveyors (bulk material)	M Washing machines	M Printing and dyeing machines
H Belt conveyors (piece goods)		M Tanning vats
U Bucket conveyors for flour	Metal working machines	M Willows
M Chain conveyors	U Countershafts, line shafts	
M Circular conveyors	H Forging presses	Waste water treatment
M Goods lifts	H Hammers *	M Aerators *
	U Machine tools, auxiliary drives	Pumps
M Hauling winches	M Machine tools, main drives	U Centrifugal pumps (light liquids)
H Hoists *		M Centrifugal pumps (viscous liquids)
	H Metal planing machines	
M Link conveyors	H Plate straightening machines	H Piston pumps
M Passenger lifts	H Presses	H Plunger pumps *
M Screw conveyors	H Punch presses	H Pressure pumps *
M Steel belt conveyors	M Shears	M Suction pumps
	M Sheet metal bending machines	
M Trough chain conveyors		Wood working machines
Cooling towers	Metal working mills	M Planing machines
U Blowers (axial and radial)	H Ingot pushers *	H Saw frames *
M Cooling tower fans	M Plate tilters *	U Wood working machines
	M Roller straighteners *	
	H Roller tables (heavy) *	
	M Roller tables (light) *	

8. RADIAL LOADS F_r

When determining the resulting radial loads, the type of transmission elements, mounted on the shaft end must be considered. Various transmission elements are corresponding with following transmission element factors f_z :

Transmission element	Transmission element factor f_z	Comments
Gears	1.00	≥ 17 / teeth
	1.15	< 17 / teeth
Chain sprockets	1.00	≥ 20 / teeth
	1.25	< 20 / teeth
	1.40	< 13 / teeth
Narrow V-belt pulleys	1.75	Influence of the tensile force
Flat belt pulleys	2.50	Influence of the tensile force
Toothed belt pulleys	2.50	Influence of the tensile force

The overhung loads exerted on the motor or gear shaft is then calculated as follows:

$$F_r = \frac{M \cdot 2000 \cdot f_z}{d_0} \quad [\text{N}]$$

F_r Resulting radial load [N]

M Torque on the shaft [Nm]

d_0 Mean diameter of the mounted transmission element in [mm]

f_z Transmission element factor

The allowed radial load force on the shaft is calculated with the following formula:

$$F_x L \leq \frac{F_{r2} \cdot a}{(b+x)} \quad [\text{N}]$$

F_{r2} Permitted overhung load ($x = L/2$) for foot-mounted gear units according to the selection tables in [N]

a, b Gear unit constant for overhung load conversion [mm]

x Distance from the shaft shoulder to the force application point in (mm)

The values of a , b , F_{r2} are given in the following tables:

Output shafts radial loads

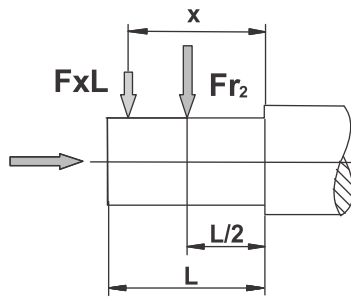

FH	20	25	30	35	50
a	102.5	134.5	138	143	213
b	82.5	109.5	108	108	163
Fr₂ max	1900	4500	5200	6500	15000

Input shafts radial loads

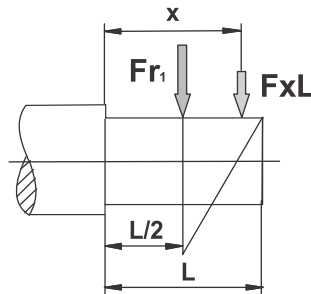

FH	20	25	30	35	50
a	80.5	82.5	103	103	134.5
b	60.5	62.5	78	78	104.5
Fr₁ max	1100	1550	3000	3000	4700

9. POSSIBLE ASSEMBLING

FH20

i	IEC63	IEC71	IEC80	IEC90
4.92				
7.21				
8.32				
9.70				
11.47				
13.84				
15.90				
18.33				
21.38				
25.29				
30.50				
33.82				
42.67				

FH25

i	IEC63	IEC71	IEC80	IEC90
5.01				
6.22				
7.16				
8.82				
10.30				
12.22				
14.24				
17.68				
20.36				
25.08				
29.27				
34.76				
38.71				
48.66				
60.40				
69.58				
85.69				
100.02				
118.75				
132.27				

FH30

i	IEC71	IEC80	IEC90	IEC100	IEC112
5.44					
7.06					
8.72					
10.19					
12.11					
14.10					
18.30					
22.59					
26.40					
31.38					
38.18					
48.18					
62.53					
77.18					
90.20					
107.23					
130.45					

FH35

i	IEC71	IEC80	IEC90	IEC100	IEC112
5.44					
7.06					
8.72					
10.19					
12.11					
14.10					
18.30					
22.59					
26.40					
31.38					
38.18					
48.18					
62.53					
77.18					
90.20					
107.23					
130.45					

FH50

i	IEC80	IEC90	IEC100	IEC112	IEC132	IEC160
5.62						
7.06						
8.72						
10.19						
12.11						
14.57						
18.30						
22.59						
26.40						
31.38						
38.18						
49.32						
61.94						
76.45						
89.35						
106.22						
129.23						

10. MOUNTING POSITIONS

MOUNTING POSITION FOR GEAR BOX & GEARED MOTOR

F - FOOT MOUNTING

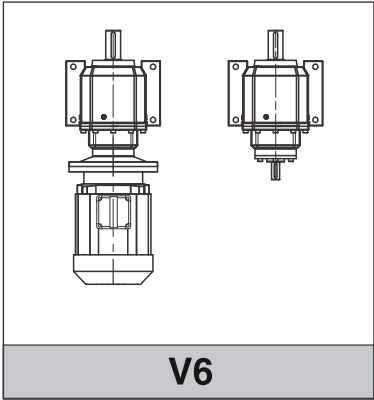
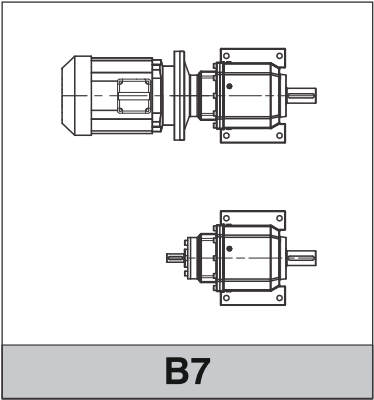
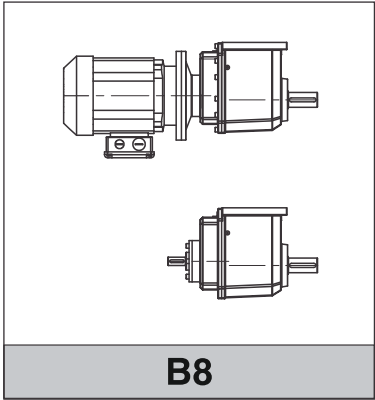
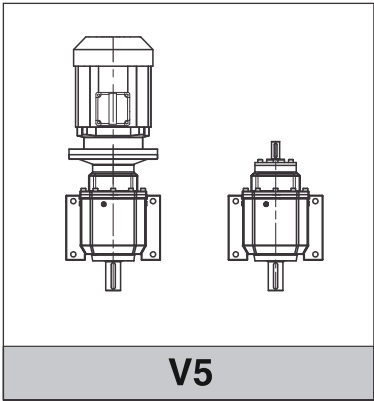
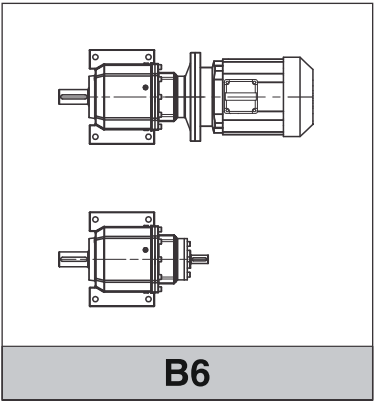
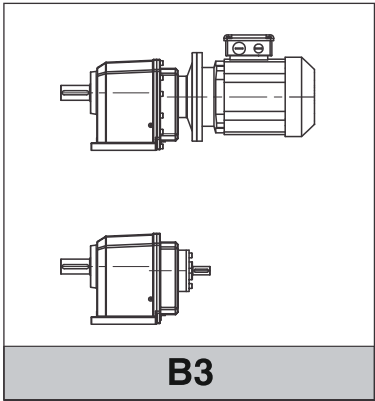

FL - FLANGE MOUNTING

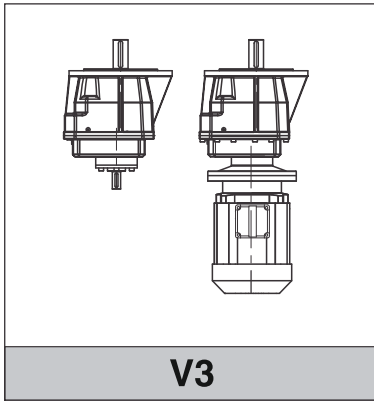
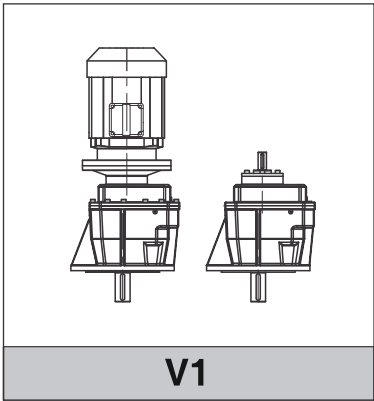
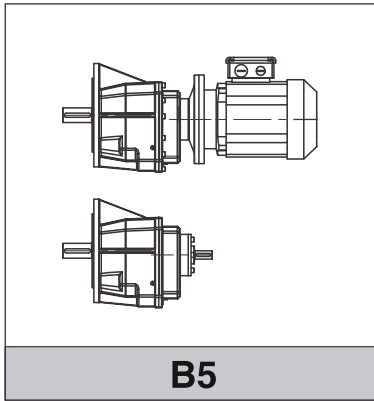

11. LUBRICATION

The gearbox inner parts are flash lubricated and filled with mineral oil. Synthetic oil is optional for Life long free maintenance. In case of temperatures under -15°C or over 50°C it is necessary to use oil seals with special materials.

QUANTITY OF LUBRICANT

MODEL	FH20-2	FH25-2	FH25-3	FH30-2/FH35-2	FH30-3/FH35-3	FH50-2	FH50-3
OIL QTY in Ltrs	0.7	1.0	1.2	1.5	1.8	4.5	5

LUBRICANT DETAILS

TYPE OF DUTY	TEMPERATURE $0^{\circ}\text{C} - 20^{\circ}\text{C}$		TEMPERATURE $20^{\circ}\text{C} - 50^{\circ}\text{C}$	
	MINERAL OIL - ISO VG	SYNTHETIC OIL - ISO VG	MINERAL OIL - ISO VG	SYNTHETIC OIL - ISO VG
LIGHT DUTY	150	150	220	220
MEDIUM DUTY	150	150	320	220
HEAVY DUTY	200	200	460	320

12. SYMBOLS AND UNITS OF MEASURE

P_{1n} [kW]	n_2 [r/min]	M_{2n} [Nm]	i	F_{r2} [N]	f_s			
------------------	------------------	------------------	-----	-----------------	-------	--	---	---

P_{1n} Rated power driving motor [kW];

n_2 Output speed [r/min];

M_{2n} Rated output torque [Nm];

i Gear unit ratio;

F_{r2} Output Shaft radial load;

f_s Service factor;

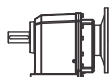

Gear unit type;

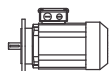



Motor type;





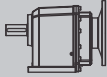
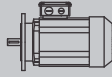

Page number - Dimension details



13. HELICAL GEAR UNIT SELECTION TABLES

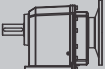
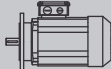

13.1 FH..(IEC).. Performance Parameter

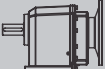
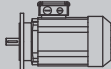

P1n [kW]	n2 [r/min]	M2n [Nm]	i	Fr ₂ [N]	f _s			
0.12	6.8	163	132.27	4500	1.2	FH25 3 63B5	FM 63 A6	47
	7.6	147	118.75	4500	1.5	FH25 3 63B5	FM 63 A6	47
	9.0	124	100.02	4500	1.7	FH25 3 63B5	FM 63 A6	47
	10.6	105	132.27	4500	2.5	FH25 3 63B5	FM 63 A4	47
	10.7	104	130.45	5200	4.3	FH30 3 63B5	FM 63 A4	51
	10.7	104	130.45	6500	4.3	FH35 3 63B5	FM 63 A4	55
	11.8	94	118.75	4500	2.7	FH25 3 63B5	FM 63 A4	47
	13.1	85	107.23	5200	4.9	FH30 3 63B5	FM 63 A4	51
	13.1	85	107.23	6500	4.9	FH35 3 63B5	FM 63 A4	55
	14.0	79	100.02	4500	3.3	FH25 3 63B5	FM 63 A4	47
	15.5	72	90.2	5200	5.8	FH30 3 63B5	FM 63 A4	51
	15.5	72	90.2	6500	5.8	FH35 3 63B5	FM 63 A4	55
	16.3	68	85.69	4500	3.7	FH25 3 63B5	FM 63 A4	47
	20.1	55	69.58	4500	4.6	FH25 3 63B5	FM 63 A4	47
	23.2	48	60.4	4500	5.4	FH25 3 63B5	FM 63 A4	47
	28.8	39	48.66	4500	6.2	FH25 3 63B5	FM 63 A4	47
	32.8	34	42.67	1900	3.3	FH20 2 63B5	FM 63 A4	44
	41.4	27	33.82	1900	4.1	FH20 2 63B5	FM 63 A4	44
	45.9	24	30.5	1900	4.5	FH20 2 63B5	FM 63 A4	44
	55.4	20	25.29	1900	5.3	FH20 2 63B5	FM 63 A4	44
	65.5	17	21.38	1900	6.3	FH20 2 63B5	FM 63 A4	44
	76.4	15	18.33	1900	7.3	FH20 2 63B5	FM 63 A4	44
	88.1	13	15.9	1850	9.4	FH20 2 63B5	FM 63 A4	44
	101.2	11	13.84	1850	11.2	FH20 2 63B5	FM 63 A4	44
	122.1	9	11.47	1650	11.7	FH20 2 63B5	FM 63 A4	44
	144.3	8	9.7	1630	12.5	FH20 2 63B5	FM 63 A4	44
	168.3	7	8.32	1600	14.2	FH20 2 63B5	FM 63 A4	44
	194.2	6	7.21	1400	15.8	FH20 2 63B5	FM 63 A4	44
284.6	4	4.92	790	18.3	FH20 2 63B5	FM 63 A4	44	
0.18	6.8	245	132.27	4500	0.8	FH25 3 63B5	FM 63 B6	47
	7.6	220	118.75	4500	1.0	FH25 3 63B5	FM 63 B6	47
	9.0	185	100.02	4500	1.1	FH25 3 63B5	FM 63 B6	47
	10.6	158	132.27	4500	1.2	FH25 3 63B5	FM 63 B4	47
	10.7	155	130.45	5200	2.9	FH30 3 63B5	FM 63 B4	51
	10.7	155	130.45	6500	2.9	FH35 3 63B5	FM 63 B4	55
	11.8	141	118.75	4500	1.3	FH25 3 63B5	FM 63 B4	47
	13.1	128	107.23	5200	3.3	FH30 3 63B5	FM 63 B4	51

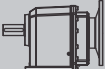
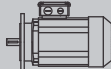

P _{1n} [kW]	n ₂ [r/min]	M _{2n} [Nm]	i	Fr ₂ [N]	f _s			
0.18	13.1	128	107.23	6500	3.3	FH35 3 63B5	FM 63 B4	55
	14.0	119	100.02	4500	1.6	FH25 3 63B5	FM 63 B4	47
	15.5	107	90.2	5200	3.8	FH30 3 63B5	FM 63 B4	51
	15.5	107	90.2	6500	3.8	FH35 3 63B5	FM 63 B4	55
	16.3	102	85.69	4500	1.8	FH25 3 63B5	FM 63 B4	47
	20.1	83	69.58	4500	2.2	FH25 3 63B5	FM 63 B4	47
	21.1	79	42.67	1900	1.6	FH20 2 71B5	FM 71 A6	44
	26.6	63	33.82	1900	1.9	FH20 2 71B5	FM 71 A6	44
	29.5	57	30.5	1900	2.1	FH20 2 71B5	FM 71 A6	44
	32.8	51	42.67	1900	2.2	FH20 2 63B5	FM 63 B4	44
	35.6	47	25.29	1900	2.6	FH20 2 71B5	FM 71 A6	44
	41.4	40	33.82	1900	2.7	FH20 2 63B5	FM 63 B4	44
	42.1	40	21.38	1900	2.9	FH20 2 71B5	FM 71 A6	44
	45.9	36	30.5	1900	3.0	FH20 2 63B5	FM 63 B4	44
	49.1	34	18.33	1900	3.4	FH20 2 71B5	FM 71 A6	44
	55.4	30	25.29	1900	3.6	FH20 2 63B5	FM 63 B4	44
	56.6	29	15.9	1850	3.9	FH20 2 71B5	FM 71 A6	44
	65.0	26	13.84	1850	5.9	FH20 2 71B5	FM 71 A6	44
	65.5	25	21.38	1900	4.2	FH20 2 63B5	FM 63 B4	44
	65.6	25	42.67	1900	4.4	FH20 2 63B5	FM 63 A2	44
	76.4	22	18.33	1900	4.8	FH20 2 63B5	FM 63 B4	44
	78.5	21	11.47	1650	7.1	FH20 2 71B5	FM 71 A6	44
	82.8	20	33.82	1900	5.6	FH20 2 63B5	FM 63 A2	44
	88.1	19	15.9	1850	6.3	FH20 2 63B5	FM 63 B4	44
	91.8	18	30.5	1900	6.1	FH20 2 63B5	FM 63 A2	44
	92.8	18	9.7	1630	7.7	FH20 2 71B5	FM 71 A6	44
	101.2	16	13.84	1850	7.4	FH20 2 63B5	FM 63 B4	44
	108.2	15	8.32	1600	8.9	FH20 2 71B5	FM 71 A6	44
	110.7	15	25.29	1900	7.3	FH20 2 63B5	FM 63 A2	44
	122.1	14	11.47	1650	7.8	FH20 2 63B5	FM 63 B4	44
	124.8	13	7.21	1400	10.0	FH20 2 71B5	FM 71 A6	44
	131.0	13	21.38	1900	8.5	FH20 2 63B5	FM 63 A2	44
144.3	12	9.7	1630	8.3	FH20 2 63B5	FM 63 B4	44	
152.8	11	18.33	1900	8.9	FH20 2 63B5	FM 63 A2	44	
168.3	10	8.32	1600	9.4	FH20 2 63B5	FM 63 B4	44	
176.1	9	15.9	1850	9.8	FH20 2 63B5	FM 63 A2	44	
182.9	9	4.92	790	11.1	FH20 2 71B5	FM 71 A6	44	
194.2	9	7.21	1400	10.6	FH20 2 63B5	FM 63 B4	44	
202.3	8	13.84	1850	11.0	FH20 2 63B5	FM 63 A2	44	
244.1	7	11.47	1650	11.4	FH20 2 63B5	FM 63 A2	44	

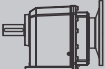
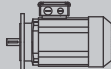

P _{1n} [kW]	n ₂ [r/min]	M _{2n} [Nm]	i	Fr ₂ [N]	f _s			
0.18	284.6	6	4.92	790	12.2	FH20 2 63B5	FM 63 B4	44
	288.7	6	9.7	1630	13.3	FH20 2 63B5	FM 63 A2	44
	336.5	5	8.32	1600	15.4	FH20 2 63B5	FM 63 A2	44
	388.3	4	7.21	1400	17.2	FH20 2 63B5	FM 63 A2	44
	569.1	3	4.92	790	22.8	FH20 2 63B5	FM 63 A2	44
0.25	9.0	257	100.02	4500	0.8	FH25 2 71B5	FM 71 B6	46
	10.5	220	85.69	4500	1.0	FH25 3 71B5	FM 71 B6	47
	10.6	218	132.27	4500	1.2	FH25 3 71B5	FM 71 A4	47
	11.8	196	118.75	4500	1.3	FH25 3 71B5	FM 71 A4	47
	12.9	179	69.58	4500	1.2	FH25 3 71B5	FM 71 B6	47
	14.0	165	100.02	4500	1.6	FH25 3 71B5	FM 71 A4	47
	14.9	155	60.4	4500	1.4	FH25 3 71B5	FM 71 B6	47
	16.3	141	85.69	4500	1.8	FH25 3 71B5	FM 71 A4	47
	18.5	125	48.66	4500	1.6	FH25 3 71B5	FM 71 B6	47
	20.1	115	69.58	4500	2.2	FH25 3 71B5	FM 71 A4	47
	21.1	109	42.67	1900	1.1	FH20 2 71B5	FM 71 B6	44
	21.2	109	132.27	4500	2.0	FH25 3 71B5	FM 63 B2	47
	23.2	99	60.4	4500	2.6	FH25 3 71B5	FM 71 A4	47
	23.6	98	118.75	4500	2.1	FH25 3 63B5	FM 63 B2	47
	25.9	89	34.76	3400	2.3	FH25 2 71B5	FM 71 B6	46
	26.6	87	33.82	1900	1.4	FH20 2 71B5	FM 71 B6	44
	28.0	82	100.02	4500	2.4	FH25 3 63B5	FM 63 B2	47
	28.8	80	48.66	4500	3.0	FH25 3 71B5	FM 71 A4	47
	29.5	78	30.5	1900	1.5	FH20 2 71B5	FM 71 B6	44
	30.7	75	29.27	3000	2.6	FH25 2 71B5	FM 71 B6	44
	32.7	70	85.69	4500	2.8	FH25 3 63B5	FM 63 B2	45
	32.8	70	42.67	1900	1.6	FH20 2 71B5	FM 71 A4	42
	35.6	65	25.29	1900	1.8	FH20 2 71B5	FM 71 B6	42
	35.9	64	25.08	2700	3.4	FH25 2 71B5	FM 71 B6	46
	36.2	64	38.71	3650	3.8	FH25 2 71B5	FM 71 A4	46
	40.2	57	69.58	4500	3.4	FH25 3 63B5	FM 63 B2	47
	41.4	55	33.82	1900	2.0	FH20 2 71B5	FM 71 A4	44
	42.1	55	21.38	1900	2.1	FH20 2 71B5	FM 71 B6	44
	45.9	50	30.5	1900	2.2	FH20 2 71B5	FM 71 A4	44
	49.1	47	18.33	1900	2.5	FH20 2 71B5	FM 71 B6	44
	55.4	41	25.29	1900	2.6	FH20 2 71B5	FM 71 A4	44
	56.6	40	15.9	1850	2.8	FH20 2 71B5	FM 71 B6	44
65.5	35	21.38	1900	3.0	FH20 2 71B5	FM 71 A4	44	
65.6	35	42.67	1900	3.2	FH20 2 63B5	FM 63 B2	44	

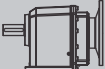
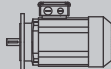

P _{1n} [kW]	n ₂ [r/min]	M _{2n} [Nm]	i	Fr ₂ [N]	f _s			
0.25	76.4	30	18.33	1900	3.5	FH20 2 71B5	FM 71 A4	44
	92.8	25	9.7	1630	5.5	FH20 2 71B5	FM 71 B6	44
	98.3	23	14.24	2200	7.6	FH25 2 71B5	FM 71 A4	46
	101.2	22	13.84	1850	5.4	FH20 2 71B5	FM 71 A4	44
	102.0	22	8.82	2250	6.6	FH25 2 71B5	FM 71 B6	46
	108.2	21	8.32	1600	6.4	FH20 2 71B5	FM 71 B6	44
	110.7	20	25.29	1900	5.2	FH20 2 63B5	FM 63 B2	44
	114.6	20	12.22	2350	7.3	FH25 2 71B5	FM 71 A4	46
	122.1	19	11.47	1650	5.6	FH20 2 71B5	FM 71 A4	44
	124.8	18	7.21	1400	7.2	FH20 2 71B5	FM 71 B6	44
	125.7	18	7.16	2050	7.6	FH25 2 71B5	FM 71 B6	46
	131.0	17	21.38	1900	6.1	FH20 2 63B5	FM 63 B2	44
	135.9	17	10.3	2250	8.0	FH25 2 71B5	FM 71 A4	46
	144.3	16	9.7	1630	6.0	FH20 2 71B5	FM 71 A4	44
	144.7	16	6.22	1950	7.8	FH25 2 71B5	FM 71 B6	46
	152.8	15	18.33	1900	6.4	FH20 2 63B5	FM 63 B2	44
	158.7	14	8.82	2250	8.7	FH25 2 71B5	FM 71 A4	46
	168.3	13	8.32	1600	6.8	FH20 2 71B5	FM 71 A4	44
	176.1	13	15.9	1850	7.0	FH20 2 63B5	FM 63 B2	44
	179.6	12	5.01	1850	8.8	FH25 2 71B5	FM 71 B6	46
	182.9	12	4.92	790	8.0	FH20 2 71B5	FM 71 B6	44
	194.2	11	7.21	1400	7.6	FH20 2 71B5	FM 71 A4	44
	195.5	11	7.16	2050	10.0	FH25 2 71B5	FM 71 A4	46
	202.3	11	13.84	1850	7.9	FH20 2 63B5	FM 63 B2	44
	244.1	9	11.47	1650	8.2	FH20 2 63B5	FM 63 B2	44
	279.4	8	5.01	1850	12.8	FH25 2 71B5	FM 71 A4	46
	284.6	8	4.92	790	8.8	FH20 2 71B5	FM 71 A4	44
	288.7	8	9.7	1630	9.6	FH20 2 63B5	FM 63 B2	44
	336.5	6	8.32	1600	11.1	FH20 2 63B5	FM 63 B2	44
	388.3	6	7.21	1400	12.4	FH20 2 63B5	FM 63 B2	44
569.1	4	4.92	790	16.4	FH20 2 63B5	FM 63 B2	44	

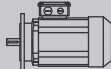

P _{1n} [kW]	n ₂ [r/min]	M _{2n} [Nm]	i	Fr ₂ [N]	f _s			
0.37	6.9	496	130.45	5200	1.0	FH30 3 80B5	FM 80 A6	51
	6.9	496	130.45	6500	1.0	FH35 3 80B5	FM 80 A6	55
	7.0	731	129.23	15000	2.6	FH50 3 80B5	FM 80 A6	59
	8.4	408	107.23	5200	1.2	FH30 3 80B5	FM 80 A6	51
	8.4	408	107.23	6500	1.2	FH35 3 80B5	FM 80 A6	55
	8.5	601	106.22	15000	3.1	FH50 3 80B5	FM 80 A6	59
	10.0	343	90.2	5200	1.4	FH30 3 80B5	FM 80 A6	51
	10.0	343	90.2	6500	1.4	FH35 3 80B5	FM 80 A6	55
	10.1	505	89.35	15000	3.6	FH50 3 80B5	FM 80 A6	59
	10.6	323	132.27	4500	0.8	FH25 3 71B5	FM 71 B4	47
	14.0	244	100.02	4500	1.1	FH25 3 71B5	FM 71 B4	47
	16.3	209	85.69	4500	1.2	FH25 3 71B5	FM 71 B4	47
	20.1	170	69.58	4500	1.5	FH25 3 71B5	FM 71 B4	47
	11.7	293	77.18	5200	1.6	FH30 3 80B5	FM 80 A6	51
	11.7	293	77.18	6500	1.6	FH35 3 80B5	FM 80 A6	55
	11.8	290	118.75	4500	0.9	FH25 3 71B5	FM 71 B4	47
	12.9	265	69.58	4500	0.8	FH25 3 80B5	FM 80 A6	47
	14.4	238	62.53	5200	1.9	FH30 3 80B5	FM 80 A6	51
	14.4	238	62.53	6500	1.9	FH35 3 80B5	FM 80 A6	55
	14.9	230	60.4	4500	0.9	FH25 3 80B5	FM 80 A6	47
	18.5	185	48.66	4500	1.1	FH25 3 80B5	FM 80 A6	47
	18.7	183	48.18	5000	2.4	FH30 3 80B5	FM 80 A6	51
	18.7	183	48.18	6250	2.4	FH35 3 80B5	FM 80 A6	55
	21.1	162	42.67	1900	0.8	FH20 2 80B5	FM 80 A6	44
	21.2	161	132.27	4500	1.3	FH25 3 71B5	FM 71 A2	47
	21.5	159	130.45	5200	2.8	FH30 3 71B5	FM 71 A2	51
	21.5	159	130.45	6500	2.8	FH35 3 71B5	FM 71 A2	55
	23.2	147	60.4	4500	1.7	FH25 3 71B5	FM 71 B4	47
	23.6	145	118.75	4500	1.4	FH25 3 71B5	FM 71 A2	47
	23.6	145	38.18	4600	2.6	FH30 2 80B5	FM 80 A6	50
	23.6	145	38.18	5750	2.6	FH35 2 80B5	FM 80 A6	54
	25.9	132	34.76	3400	1.5	FH25 2 80B5	FM 80 A6	46
	26.1	131	107.23	5200	3.2	FH30 3 71B5	FM 71 A2	51
	26.1	131	107.23	6500	3.2	FH35 3 71B5	FM 71 A2	55
	26.6	128	33.82	1900	0.9	FH20 2 80B5	FM 80 A6	44
	28.0	122	100.02	4500	1.6	FH25 3 71B5	FM 71 A2	47
	28.7	119	31.38	4080	2.7	FH30 2 80B5	FM 80 A6	50
	28.7	119	31.38	5100	2.7	FH35 2 80B5	FM 80 A6	54
	28.8	119	48.66	4500	2.1	FH25 3 71B5	FM 71 A2	47
	29.5	116	30.5	1900	1.0	FH20 2 80B5	FM 80 A6	44
30.7	111	29.27	3000	1.8	FH25 2 80B5	FM 80 A6	46	

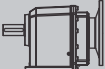
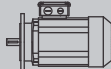

P _{1n} [kW]	n ₂ [r/min]	M _{2n} [Nm]	i	Fr ₂ [N]	f _s			
0.37	31.0	110	90.2	5200	3.9	FH30 3 71B5	FM 71 A2	51
	31.0	110	90.2	6500	3.9	FH35 3 71B5	FM 71 A2	55
	32.7	104	85.69	4500	1.9	FH25 3 71B5	FM 71 A2	47
	34.1	100	26.4	3760	3.0	FH30 2 80B5	FM 80 A6	50
	34.1	100	26.4	4700	3.0	FH35 2 71B5	FM 80 A6	54
	32.8	104	42.67	1900	1.1	FH20 2 71B5	FM 71 B4	44
	35.6	96	25.29	1900	1.2	FH20 2 80B5	FM 80 A6	44
	35.9	95	25.08	2700	2.3	FH25 2 80B5	FM 80 A6	46
	36.2	94	38.71	3650	2.6	FH25 2 71B5	FM 71 B4	
	36.3	94	77.18	5200	4.6	FH30 3 71B5	FM 71 A2	51
	36.3	94	77.18	6500	4.6	FH35 3 71B5	FM 71 A2	51
	39.8	86	22.59	3520	3.2	FH30 2 80B5	FM 80 A6	50
	39.8	86	22.59	4400	3.2	FH35 2 80B5	FM 80 A6	54
	40.2	85	69.58	4500	2.3	FH25 3 71B5	FM 71 A2	47
	40.3	85	34.76	3400	2.8	FH25 3 71B5	FM 71 B4	47
	41.4	82	33.82	1900	1.3	FH20 2 71B5	FM 71 B4	44
	42.1	81	21.38	1900	1.4	FH20 2 80B5	FM 80 A6	44
	44.2	77	20.36	2500	2.8	FH25 2 80B5	FM 80 A6	46
	45.9	74	30.5	1900	1.5	FH20 2 71B5	FM 71 B4	44
	46.4	73	60.4	4500	2.6	FH25 3 71B5	FM 71 A2	47
	47.8	71	29.27	3000	3.2	FH25 2 71B5	FM 71 B4	46
	49.1	69	18.33	1900	1.7	FH20 2 80B5	FM 80 A6	44
	50.9	67	17.68	2250	3.5	FH25 2 80B5	FM 80 A6	46
	55.4	61	25.29	1900	1.7	FH20 2 71B5	FM 71 B4	44
	55.8	61	25.08	2700	3.5	FH25 2 71B5	FM 71 B4	46
	56.6	60	15.9	1850	1.9	FH20 2 80B5	FM 80 A6	44
	57.5	59	48.66	4500	3.2	FH25 3 71B5	FM 71 A2	47
	63.2	54	14.24	2200	3.9	FH25 2 80B5	FM 80 A6	46
	65.0	52	13.84	1850	2.9	FH20 2 80B5	FM 80 A6	42
	65.5	52	21.38	1900	2.0	FH20 2 71B5	FM 71 B4	44
	65.6	35	42.67	1900	2.2	FH20 2 71B5	FM 71 A2	44
	76.4	44	18.33	1900	2.4	FH20 2 71B5	FM 71 B4	44
	78.5	43	11.47	1650	3.5	FH20 2 80B5	FM 80 A6	44
	92.8	36	9.7	1630	3.7	FH20 2 80B5	FM 80 A6	44
	82.8	28	33.82	1900	2.7	FH20 2 71B5	FM 71 A2	44
	88.1	38	15.9	1850	3.1	FH20 2 71B5	FM 71 B4	44
91.8	25	30.5	1900	3.0	FH20 2 71B5	FM 71 A2	44	
101.2	33	13.84	1850	3.6	FH20 2 71B5	FM 71 B4	44	
110.7	20	25.29	1900	3.5	FH20 2 71B5	FM 71 A2	44	
122.1	28	11.47	1650	3.8	FH20 2 71B5	FM 71 B4	44	

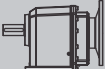
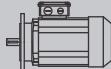

P _{1n} [kW]	n ₂ [r/min]	M _{2n} [Nm]	i	Fr ₂ [N]	f _s			
0.37	124.8	27	7.21	1400	4.9	FH20 2 80B5	FM 80 A6	44
	144.3	23	9.7	1630	4.1	FH20 2 71B5	FM 71 B4	44
	152.8	15	18.33	1900	4.3	FH20 2 71B5	FM 71 A2	44
	168.3	20	8.32	1600	4.6	FH20 2 71B5	FM 71 B4	44
	176.1	13	15.9	1850	4.8	FH20 2 71B5	FM 71 A2	44
	182.9	18	4.92	790	5.4	FH20 2 80B5	FM 80 A6	44
	194.2	17	7.21	1400	5.1	FH20 2 71B5	FM 71 B4	44
	202.3	11	13.84	1850	5.4	FH20 2 71B5	FM 71 A2	44
	244.1	9	11.47	1650	5.6	FH20 2 71B5	FM 71 A2	44
	288.7	8	9.7	1630	6.5	FH20 2 71B5	FM 71 A2	44
	284.6	12	4.92	790	5.9	FH20 2 71B5	FM 71 B4	44
	336.5	6	8.32	1600	7.5	FH20 2 71B5	FM 71 A2	44
	388.3	6	7.21	1400	8.4	FH20 2 71B5	FM 71 A2	44
	569.1	4	4.92	790	11.1	FH20 2 71B5	FM 71 A2	44
	0.55	7.0	731	129.23	15000	1.7	FH50 3 80B5	FM 80 B6
8.4		607	107.23	5200	0.8	FH30 3 80B5	FM 80 B6	51
8.4		607	107.23	6500	0.8	FH35 3 80B5	FM 80 B6	55
8.5		601	106.22	15000	2.1	FH50 3 80B5	FM 80 B6	59
10.0		510	90.2	5200	0.9	FH30 3 80B5	FM 80 B6	51
10.0		510	90.2	6500	0.9	FH35 3 80B5	FM 80 B6	55
10.1		505	89.35	15000	2.4	FH50 3 80B5	FM 80 B6	59
10.7		474	130.45	5200	0.9	FH30 3 80B5	FM 80 A4	51
10.7		474	130.45	6500	0.9	FH35 3 80B5	FM 80 A4	55
10.8		470	129.23	15000	2.8	FH50 3 80B5	FM 80 A4	59
11.7		436	77.18	5200	1.1	FH30 3 80B5	FM 80 B6	51
11.7		436	77.18	6500	1.1	FH35 3 80B5	FM 80 B6	55
11.8		432	76.45	15000	2.8	FH50 3 80B5	FM 80 B6	59
13.1		390	107.23	5200	1.1	FH30 3 80B5	FM 80 A4	51
13.1		390	107.23	6500	1.1	FH35 3 80B5	FM 80 A4	55
13.2		386	106.22	15000	3.3	FH50 3 80B5	FM 80 A4	59
14.4		354	62.53	5200	1.3	FH30 3 80B5	FM 80 B6	51
14.4		354	62.53	6500	1.3	FH35 3 80B5	FM 80 B6	55
14.5		350	61.94	15000	3.4	FH50 3 80B5	FM 80 B6	59
15.5		328	90.2	5200	1.3	FH30 3 80B5	FM 80 A4	51
15.5		328	90.2	6500	1.3	FH35 3 80B5	FM 80 A4	55
16.3		311	85.69	4500	0.8	FH35 3 80B5	FM 80 A4	55
18.1		280	77.18	5200	1.5	FH30 3 80B5	FM 80 A4	51
18.1		280	77.18	6500	1.5	FH35 3 80B5	FM 80 A4	55
18.7		272	48.18	5000	1.6	FH30 3 80B5	FM 80 B6	51
18.7		272	48.18	6250	1.6	FH35 3 80B5	FM 80 B6	55

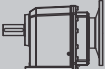
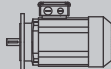

P _{1n} [kW]	n ₂ [r/min]	M _{2n} [Nm]	i	Fr ₂ [N]	f _s			
0.55	20.1	253	69.58	4500	1.0	FH25 3 80B5	FM 80 A4	47
	21.2	240	132.27	4500	0.9	FH25 3 71B5	FM 71 B2	47
	21.5	237	130.45	5200	1.9	FH30 3 80B5	FM 71 B2	51
	21.5	237	130.45	6500	1.9	FH35 3 71B5	FM 71 B2	55
	22.4	227	62.53	5200	1.8	FH30 3 80B5	FM 80 A4	
	22.4	227	62.53	6500	1.8	FH35 3 80B5	FM 80 A4	55
	23.2	219	60.4	4500	1.2	FH25 3 80B5	FM 80 A4	47
	23.2	219	38.71	3650	0.9	FH25 2 80B5	FM 80 B6	46
	23.6	216	118.75	4500	0.9	FH25 3 71B5	FM 71 B2	47
	23.6	216	38.18	4600	1.7	FH30 2 80B5	FM 80 B6	50
	23.6	216	38.18	5750	1.7	FH35 2 80B5	FM 80 B6	54
	25.9	196	34.76	3400	1.0	FH25 2 80B5	FM 80 B6	46
	26.1	195	107.23	5200	2.2	FH30 3 80B5	FM 71 B2	51
	26.1	195	107.23	6500	2.2	FH35 3 71B5	FM 71 B2	55
	28.0	182	100.02	4500	1.1	FH25 3 71B5	FM 71 B2	47
	28.7	177	31.38	4080	1.8	FH30 2 80B5	FM 80 B6	50
	28.7	177	31.38	5100	1.8	FH35 3 80B5	FM 80 B6	55
	28.8	177	48.66	4500	1.4	FH25 3 80B5	FM 80 A4	47
	29.1	175	48.18	5000	2.3	FH30 3 80B5	FM 80 A4	51
	29.1	175	48.18	6250	2.3	FH35 3 80B5	FM 80 A4	55
	30.7	165	29.27	3000	1.2	FH25 2 80B5	FM 80 B6	46
	31.0	164	90.2	5200	2.6	FH30 3 80B5	FM 71 B2	51
	31.0	164	90.2	6500	2.6	FH35 3 71B5	FM 71 B2	55
	32.7	155	85.69	4500	1.3	FH25 3 71B5	FM 71 B2	47
	34.1	149	26.4	3760	2.0	FH30 2 80B5	FM 80 B6	50
	34.1	149	26.4	4700	2.1	FH35 2 80B5	FM 80 B6	54
	35.6	143	25.29	1900	0.8	FH20 2 80B5	FM 80 B6	44
	35.9	142	25.08	2700	1.5	FH25 2 80B5	FM 80 B6	46
	36.3	140	77.18	5200	3.1	FH30 3 80B5	FM 71 B2	51
	36.3	140	77.18	6500	3.1	FH35 2 71B5	FM 71 B2	54
	36.2	140	38.71	3650	1.7	FH25 2 80B5	FM 80 A4	46
	36.7	138	38.18	4600	2.9	FH30 2 80B5	FM 80 A4	50
	36.7	138	38.18	5750	2.9	FH35 2 80B5	FM 80 A4	52
	39.8	127	22.59	3520	2.2	FH30 2 80B5	FM 80 B6	48
	39.8	127	22.59	4400	2.4	FH35 2 80B5	FM 80 B6	54
	40.2	126	69.58	4500	1.5	FH25 3 71B5	FM 71 B2	47
	40.3	126	34.76	3400	1.9	FH25 2 80B5	FM 80 A4	46
	41.4	123	33.82	1900	0.9	FH20 2 80B5	FM 80 A4	44
	42.1	121	21.38	1900	1.0	FH20 2 80B5	FM 80 B6	44
	44.2	115	20.36	2500	1.9	FH25 2 80B5	FM 80 B6	46

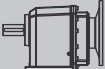
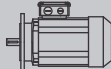

P _{1n} [kW]	n ₂ [r/min]	M _{2n} [Nm]	i	Fr ₂ [N]	f _s			
0.55	44.6	114	31.38	4080	3.5	FH30 2 80B5	FM 80 A4	50
	44.6	114	31.38	5100	3.5	FH35 2 80B5	FM 80 A4	54
	45.9	111	30.5	1900	1.0	FH20 2 80B5	FM 80 A4	44
	46.4	109	60.4	4500	1.8	FH25 3 71B5	FM 71 B2	47
	47.8	106	29.27	3000	2.2	FH25 2 80B5	FM 80 A4	46
	49.1	103	18.33	1900	1.1	FH20 2 80B5	FM 80 B6	44
	49.2	103	18.3	3280	2.6	FH30 2 80B5	FM 80 B6	50
	49.2	103	18.3	4100	3.0	FH35 2 80B5	FM 80 B6	54
	50.9	100	17.68	2250	2.4	FH25 2 80B5	FM 80 B6	46
	55.4	92	25.29	1900	1.2	FH20 2 80B5	FM 80 A4	44
	55.8	91	25.08	2700	2.6	FH25 2 80B5	FM 80 A4	46
	56.6	90	15.9	1850	1.3	FH20 2 80B5	FM 80 B6	44
	57.5	88	48.66	4500	2.2	FH25 3 71B5	FM 71 B2	47
	63.2	80	14.24	2200	2.6	FH25 2 80B5	FM 80 B6	46
	63.8	79	14.1	3120	3.6	FH30 2 80B5	FM 80 B6	50
	65.0	78	13.84	1850	1.9	FH20 2 80B5	FM 80 B6	44
	65.5	77	21.38	1900	1.4	FH20 2 80B5	FM 80 A4	44
	65.6	77	42.67	1900	1.5	FH20 2 80B5	FM 71 B2	44
	68.8	74	20.36	2500	2.7	FH25 2 80B5	FM 80 A4	46
	72.3	70	38.71	3650	2.7	FH25 3 71B5	FM 71 B2	47
	73.6	69	12.22	2350	2.5	FH25 2 80B5	FM 80 B6	46
	76.4	66	18.33	1900	1.6	FH20 2 80B5	FM 80 A4	44
	78.5	64	11.47	1650	2.3	FH20 2 80B5	FM 71 B6	44
	79.2	64	17.68	2250	3.1	FH25 2 80B5	FM 80 A4	46
	80.6	63	34.76	3400	3.0	FH25 3 71B5	FM 71 B2	47
	82.8	61	33.82	1900	1.8	FH20 2 71B5	FM 71 B2	44
	87.4	58	10.3	2250	2.7	FH25 2 80B5	FM 80 B6	46
	88.1	57	15.9	1850	2.1	FH20 2 80B5	FM 80 A4	44
	91.8	55	30.5	1900	2.0	FH20 2 71B5	FM 71 B2	44
	92.8	54	9.7	1630	2.5	FH20 2 80B5	FM 71 B6	44
	95.7	53	29.27	3000	3.5	FH25 3 71B5	FM 71 B2	47
	98.3	51	14.24	2200	3.5	FH25 2 80B5	FM 80 A4	46
	101.2	50	13.84	1850	2.4	FH20 2 80B5	FM 80 A4	44
	102.0	49	8.82	2250	3.0	FH25 2 80B5	FM 80 B6	46
	108.2	47	8.32	1600	2.9	FH20 2 80B5	FM 80 B6	44
	110.7	46	25.29	1900	2.4	FH20 2 71B5	FM 71 B2	44
	114.6	44	12.22	2350	3.3	FH25 2 80B5	FM 80 A4	46
	122.1	41	11.47	1650	2.5	FH20 2 80B5	FM 80 A4	44
	124.8	40	7.21	1400	3.3	FH20 2 80B5	FM 80 B6	44
	125.7	40	7.16	2050	3.5	FH25 2 80B5	FM 80 B6	46

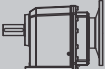
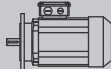

P _{1n} [kW]	n ₂ [r/min]	M _{2n} [Nm]	i	Fr ₂ [N]	f _s			
0.55	131.0	38	21.38	1900	2.8	FH20 2 71B5	FM 71 B2	44
	135.9	37	10.3	2250	3.6	FH25 2 80B5	FM 80 A4	46
	144.3	35	9.7	1630	2.7	FH20 2 80B5	FM 80 A4	44
	144.7	35	6.22	1950	3.5	FH25 2 80B5	FM 80 B6	46
	152.8	33	18.33	1900	2.9	FH20 2 71B5	FM 71 B2	44
	168.3	30	8.32	1600	3.1	FH20 2 80B5	FM 80 A4	44
	176.1	28	15.9	1850	3.2	FH20 2 71B5	FM 71 B2	44
	182.9	27	4.92	790	3.6	FH20 2 80B5	FM 80 B6	44
	194.2	26	7.21	1400	3.5	FH20 2 80B5	FM 80 A4	44
	202.3	25	13.84	1850	3.6	FH20 2 71B5	FM 71 B2	44
	244.1	20	11.47	1650	3.7	FH20 2 71B5	FM 71 B2	44
	284.6	17	4.92	790	4.0	FH20 2 80B5	FM 80 A4	44
	288.7	17	9.7	1630	4.4	FH20 2 71B5	FM 71 B2	44
	336.5	15	8.32	1600	5.1	FH20 2 71B5	FM 71 B2	44
	388.3	13	7.21	1400	5.6	FH20 2 71B5	FM 71 B2	44
	569.1	9	4.92	790	7.5	FH20 2 71B5	FM 71 B2	44
0.75	7.0	997	129.23	15000	1.3	FH50 3 90B5	FM 90 S6	59
	8.5	819	106.22	15000	1.5	FH50 3 90B5	FM 90 S6	59
	10.1	689	89.35	15000	1.8	FH50 3 90B5	FM 90 S6	59
	10.8	641	129.23	15000	2.0	FH50 3 80B5	FM 80 B4	59
	11.7	595	77.18	5200	0.8	FH30 3 90B5	FM 90 S6	51
	11.7	595	77.18	6500	0.8	FH35 3 90B5	FM 90 S6	55
	11.8	590	76.45	15000	2.1	FH50 3 90B5	FM 90 S6	59
	13.1	532	107.23	5200	0.8	FH30 3 80B5	FM 80 B4	51
	13.1	532	107.23	6500	0.8	FH35 3 80B5	FM 80 B4	55
	13.2	527	106.22	15000	2.4	FH50 3 80B5	FM 80 B4	59
	14.4	482	62.53	5200	0.9	FH30 3 90B5	FM 90 S6	51
	14.4	482	62.53	6500	0.9	FH35 3 90B5	FM 90 S6	55
	14.5	478	61.94	15000	2.5	FH50 3 90B5	FM 90 S6	59
	15.5	447	90.2	5200	0.9	FH30 3 80B5	FM 80 B4	51
	15.5	447	90.2	6500	0.9	FH35 3 80B5	FM 80 A4	55
	15.7	443	89.35	15000	2.9	FH50 3 80B5	FM 80 A4	59
	18.1	383	77.18	5200	1.1	FH30 3 80B5	FM 80 B4	51
	18.1	383	77.18	6500	1.1	FH35 3 80B5	FM 80 B4	55
	18.2	380	49.32	15000	3.1	FH50 3 90B5	FM 90 S6	59
	18.3	379	76.45	15000	3.3	FH50 3 80B5	FM 80 B4	59
	18.7	371	48.18	5000	1.2	FH30 3 90B5	FM 90 S6	51
	18.7	371	48.18	6250	1.2	FH35 3 90B5	FM 90 S6	55
	21.5	323	130.45	5200	1.4	FH30 3 80B5	FM 80 A2	51

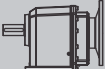
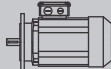

P _{1n} [kW]	n ₂ [r/min]	M _{2n} [Nm]	i	Fr ₂ [N]	f _s			
0.75	21.5	323	130.45	6500	1.4	FH35 3 80B5	FM 80 A2	55
	21.7	320	129.23	15000	2.9	FH50 3 80B5	FM 80 A2	59
	22.4	310	62.53	5200	1.3	FH30 3 80B5	FM 80 B4	51
	22.4	310	62.53	6500	1.3	FH35 3 80B5	FM 80 B4	55
	23.2	299	60.4	4500	0.9	FH25 3 80B5	FM 80 B4	47
	23.6	294	38.18	4600	1.3	FH30 2 90B5	FM 90 S6	50
	23.6	294	38.18	5750	1.3	FH35 2 90B5	FM 90 S6	54
	25.9	268	34.76	3400	0.8	FH25 2 90B5	FM 90 S6	46
	26.1	266	107.23	5200	1.6	FH30 3 80B5	FM 80 A2	51
	26.1	266	107.23	6500	1.6	FH35 3 80B5	FM 80 A2	55
	28.7	242	31.38	4080	1.3	FH30 2 90B5	FM 90 S6	50
	28.7	242	31.38	5100	1.3	FH35 2 90B5	FM 90 S6	54
	28.8	241	48.66	4500	1.0	FH25 3 80B5	FM 80 B4	47
	29.1	239	48.18	5000	1.7	FH30 3 80B5	FM 80 B4	51
	29.1	239	48.18	6250	1.7	FH35 3 80B5	FM 80 B4	55
	30.7	225	29.27	3000	0.9	FH25 2 90B5	FM 90 S6	46
	31.0	223	90.2	5200	1.9	FH30 3 80B5	FM 80 A2	51
	31.0	223	90.2	6500	1.9	FH35 3 80B5	FM 80 A2	55
	32.7	212	85.69	4500	0.9	FH25 3 80B5	FM 80 A2	47
	34.1	203	26.4	3760	1.6	FH30 2 90B5	FM 90 S6	50
	34.1	203	26.4	4700	1.6	FH35 2 90B5	FM 90 S6	54
	35.9	193	25.08	2700	1.1	FH25 2 90B5	FM 90 S6	46
	36.2	192	38.71	3650	1.3	FH25 2 80B5	FM 80 B4	46
	36.3	191	77.18	5200	2.3	FH35 2 80B5	FM 80 A2	51
	36.3	191	77.18	6500	2.3	FH35 3 80B5	FM 80 A2	55
	36.7	189	38.18	4600	2.1	FH30 2 80B5	FM 80 B4	50
	36.7	189	38.18	5750	2.1	FH35 2 80B5	FM 80 B4	54
	39.8	174	22.59	3520	1.8	FH30 2 90B5	FM 90 S6	50
	39.8	174	22.59	4400	1.8	FH35 2 90B5	FM 90 S6	54
	40.2	172	69.58	4500	1.1	FH25 3 80B5	FM 80 A2	47
	40.3	172	34.76	3400	1.4	FH25 2 80B5	FM 80 A4	46
	44.2	157	20.36	2500	1.4	FH25 2 90B5	FM 90 S6	46
	44.6	155	31.38	4080	2.6	FH30 2 80B5	FM 80 B4	50
	44.6	155	31.38	5100	2.6	FH35 2 80B5	FM 80 B4	54
	44.8	155	62.53	5200	2.7	FH30 3 80B5	FM 80 A2	51
	44.8	155	62.53	6500	2.7	FH35 3 80B5	FM 80 A2	55
	46.4	149	60.4	4500	1.3	FH25 3 80B5	FM 80 A2	47
	47.8	145	29.27	3000	1.6	FH25 2 80B5	FM 80 B4	46
	49.1	141	18.33	1900	0.8	FH20 2 90B5	FM 90 S6	44
	49.2	141	18.3	3280	2.2	FH30 2 90B5	FM 90 S6	50

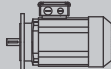

P _{1n} [kW]	n ₂ [r/min]	M _{2n} [Nm]	i	Fr ₂ [N]	f _s			
0.75	49.2	141	18.3	4100	2.2	FH35 2 90B5	FM 90 S6	54
	50.9	136	17.68	2250	1.7	FH25 2 90B5	FM 90 S6	46
	53.0	131	26.4	3760	3.0	FH30 2 80B5	FM 80 B4	50
	53.0	131	26.4	4700	3.0	FH35 2 80B5	FM 80 B4	54
	55.8	124	25.08	2700	1.9	FH25 2 80B5	FM 80 B4	46
	56.6	122	15.9	1850	0.9	FH20 2 90B5	FM 90 S6	44
	57.5	120	48.66	4500	1.6	FH25 3 80B5	FM 80 A2	47
	58.1	119	48.18	5000	3.2	FH30 3 80B5	FM 80 A2	51
	58.1	119	48.18	6250	3.2	FH35 3 80B5	FM 80 A2	55
	62.0	112	22.59	3520	3.5	FH30 2 80B5	FM 80 B4	50
	62.0	112	22.59	4400	3.5	FH35 2 80B5	FM 80 B4	54
	63.2	109	14.24	2200	1.9	FH25 2 90B5	FM 90 S6	46
	63.8	108	14.1	3120	2.8	FH30 2 90B5	FM 90 S6	50
	63.8	108	14.1	3900	2.8	FH35 2 90B5	FM 90 S6	54
	65.0	106	13.84	1850	1.4	FH20 2 90B5	FM 90 S6	44
	65.5	106	21.38	1900	1.0	FH20 2 80B5	FM 80 B4	44
	65.6	105	42.67	1900	1.1	FH20 2 80B5	FM 80 A2	44
	68.8	101	20.36	2500	2.0	FH25 2 80B5	FM 80 B4	46
	72.3	96	38.71	3650	2.0	FH25 2 80B5	FM 80 A2	46
	73.6	94	12.22	2350	1.9	FH25 2 90B5	FM 90 S6	46
	76.4	91	18.33	1900	1.2	FH20 2 80B5	FM 80 B4	44
	78.5	88	11.47	1650	1.7	FH20 2 90B5	FM 90 S6	44
	79.2	87	17.68	2250	2.3	FH25 2 80B5	FM 80 B4	46
	80.6	86	34.76	3400	2.2	FH25 2 80B5	FM 80 A2	46
	82.8	83	33.82	1900	1.3	FH20 2 80B5	FM 80 A2	44
	87.4	79	10.3	2250	2.0	FH25 2 90B5	FM 90 S6	46
	88.1	78	15.9	1850	1.5	FH20 2 80B5	FM 80 B4	44
	91.8	75	30.5	1900	1.5	FH20 2 80B5	FM 80 A2	44
	92.8	74	9.7	1630	1.8	FH20 2 90B5	FM 90 S6	44
	95.7	72	29.27	3000	2.5	FH25 2 80B5	FM 80 A2	46
	98.3	70	14.24	2200	2.5	FH25 2 80B5	FM 80 B4	46
	101.2	68	13.84	1850	1.8	FH20 2 80B5	FM 80 B4	44
	102.0	68	8.82	2250	2.2	FH25 2 90B5	FM 90 S6	46
	108.2	64	8.32	1600	2.1	FH20 2 90B5	FM 90 S6	44
	110.7	62	25.29	1900	1.7	FH20 2 80B5	FM 80 A2	44
	111.6	62	25.08	2700	2.9	FH25 2 80B5	FM 80 A2	46
	114.6	60	12.22	2350	2.4	FH25 2 80B5	FM 80 B4	46
	122.1	56	11.47	1650	1.9	FH20 2 80B5	FM 80 B4	44
	124.8	55	7.21	1400	2.4	FH20 2 90B5	FM 90 S6	44
	125.7	55	7.16	2050	2.5	FH25 2 90B5	FM 90 S6	46

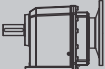
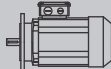

P _{1n} [kW]	n ₂ [r/min]	M _{2n} [Nm]	i	Fr ₂ [N]	f _s			
0.75	131.0	53	21.38	1900	2.0	FH20 2 80B5	FM 80 A2	44
	135.9	51	10.3	2250	2.7	FH25 2 80B5	FM 80 B4	46
	137.5	50	20.36	2500	3.5	FH25 2 80B5	FM 80 A2	46
	144.3	48	9.7	1630	2.0	FH20 2 80B5	FM 80 B4	44
	144.7	48	6.22	1950	2.6	FH25 2 90B5	FM 90 S6	46
	152.8	45	18.33	1900	2.1	FH20 2 80B5	FM 80 A2	44
	158.7	43	8.82	2250	2.9	FH25 2 80B5	FM 80 B4	46
	168.3	41	8.32	1600	2.3	FH20 2 80B5	FM 80 B4	44
	176.1	39	15.9	1850	2.3	FH20 2 80B5	FM 80 A2	44
	179.6	38	5.01	1850	2.9	FH25 2 90B5	FM 90 S6	46
	182.9	38	4.92	790	2.7	FH20 2 90B5	FM 90 S6	44
	194.2	35	7.21	1400	2.5	FH20 2 80B5	FM 80 B4	44
	195.5	35	7.16	2050	3.3	FH25 2 80B5	FM 80 B4	46
	202.3	34	13.84	1850	2.6	FH20 2 80B5	FM 80 A2	44
	225.1	30	6.22	1950	3.7	FH25 2 80B5	FM 80 B4	46
	244.1	28	11.47	1650	2.7	FH20 2 80B5	FM 80 A2	44
	284.6	24	4.92	790	2.9	FH20 2 80B5	FM 80 B4	44
	288.7	24	9.7	1630	3.2	FH20 2 80B5	FM 80 A2	44
	336.5	20	8.32	1600	3.7	FH20 2 80B5	FM 80 A2	44
	388.3	17	7.21	1400	4.1	FH20 2 80B5	FM 80 A2	44
569.1	12	4.92	790	5.5	FH20 2 80B5	FM 80 A2	44	
1.1	7.0	1463	129.23	15000	0.9	FH50 3 90B5	FM 90 L6	59
	8.5	1202	106.22	15000	1.0	FH50 3 90B5	FM 90 L6	59
	10.1	1011	89.35	15000	1.2	FH50 3 90B5	FM 90 L6	59
	10.8	940	129.23	15000	1.4	FH50 3 90B5	FM 90 S4	59
	11.8	865	76.45	15000	1.4	FH50 3 90B5	FM 90 L6	59
	13.2	773	106.22	15000	1.7	FH50 3 90B5	FM 90 S4	59
	14.5	701	61.94	15000	1.7	FH50 3 90B5	FM 90 L6	59
	15.7	650	89.35	15000	2.0	FH50 3 90B5	FM 90 S4	59
	18.2	558	49.32	15000	2.1	FH50 3 90B5	FM 90 L6	59
	18.3	556	76.45	15000	2.3	FH50 3 90B5	FM 90 S4	59
	18.7	545	48.18	5000	0.8	FH50 3 90B5	FM 90 L6	51
	18.7	545	48.18	6250	0.8	FH35 3 90B5	FM 90 L6	55
	21.5	474	130.45	5200	1.0	FH30 3 80B5	FM 80 B2	51
	21.5	474	130.45	6500	1.0	FH35 3 80B5	FM 80 B2	55
	21.7	470	129.23	15000	2.0	FH50 3 80B5	FM 80 B2	59
	22.4	455	62.53	5200	0.9	FH30 3 90B5	FM 90 S4	51
	22.4	455	62.53	6500	0.9	FH35 3 90B5	FM 90 S4	55
	22.6	450	61.94	15000	2.8	FH50 3 90B5	FM 90 S4	59
	23.6	432	38.18	4600	0.9	FH30 2 90B5	FM 90 L6	50

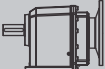
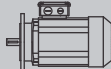

P _{1n} [kW]	n ₂ [r/min]	M _{2n} [Nm]	i	Fr ₂ [N]	f _s			
1.1	23.6	432	38.18	5750	0.9	FH35 2 90B5	FM 90 L6	53
	23.6	432	38.18	14500	2.7	FH50 3 90B5	FM 90 L6	59
	26.1	390	107.23	5200	1.1	FH30 3 80B5	FM 80 B2	51
	26.1	390	107.23	6500	1.1	FH35 3 80B5	FM 80 B2	55
	26.4	386	106.22	15000	2.4	FH50 3 80B5	FM 80 B2	59
	28.4	358	49.32	15000	3.5	FH50 3 90B5	FM 90 S4	59
	28.7	355	31.38	4080	0.9	FH30 2 90B5	FM 90 L6	50
	28.7	355	31.38	5100	0.9	FH35 2 90B5	FM 90 L6	54
	28.7	355	31.38	12900	3.3	FH50 2 90B5	FM 90 L6	58
	29.1	350	48.18	5000	1.2	FH30 3 90B5	FM 90 S4	51
	29.1	350	48.18	6250	1.2	FH35 3 90B5	FM 90 S4	55
	31.0	328	90.2	5200	1.3	FH30 3 80B5	FM 80 B2	51
	31.0	328	90.2	6500	1.3	FH35 3 80B5	FM 80 B2	55
	31.3	325	89.35	15000	2.8	FH50 3 80B5	FM 80 B2	59
	34.1	298	26.4	3760	1.1	FH30 2 90B5	FM 90 L6	50
	34.1	298	26.4	4700	1.1	FH35 2 90B5	FM 90 L6	54
	35.9	283	25.08	2700	0.8	FH25 2 90B5	FM 90 L6	46
	36.2	281	38.71	3650	0.9	FH25 2 90B5	FM 90 S4	46
	36.3	280	77.18	5200	1.5	FH30 3 80B5	FM 80 B2	51
	36.3	280	77.18	6500	1.5	FH35 3 80B5	FM 80 B2	55
	36.6	278	76.45	15000	3.3	FH50 3 80B5	FM 80 B2	59
	36.7	277	38.18	4600	1.4	FH30 2 90B5	FM 90 S4	50
	36.7	277	38.18	5750	1.4	FH35 2 90B5	FM 90 S4	54
	39.8	255	22.59	3520	1.2	FH30 2 90B5	FM 90 L6	50
	39.8	255	22.59	4400	1.2	FH35 2 90B5	FM 90 L6	54
	40.3	253	34.76	3400	1.0	FH25 2 90B5	FM 90 S4	46
	44.2	230	20.36	2500	1.0	FH25 2 90B5	FM 90 L6	46
	44.6	228	31.38	4080	1.7	FH30 2 90B5	FM 90 S4	50
	44.6	228	31.38	5100	1.7	FH35 2 90B5	FM 90 S4	54
	44.8	227	62.53	5200	1.8	FH30 3 80B5	FM 80 B2	51
	44.8	227	62.53	6500	1.8	FH35 3 80B5	FM 80 B2	55
	46.4	219	60.4	4500	0.9	FH25 3 80B5	FM 80 B2	47
	47.8	213	29.27	3000	1.1	FH25 2 90B5	FM 90 S4	46
	49.2	207	18.3	3280	1.5	FH30 2 90B5	FM 90 L6	50
	49.2	207	18.3	4100	1.5	FH35 2 90B5	FM 90 L6	54
	50.9	200	17.68	2250	1.2	FH25 2 90B5	FM 90 L6	46
	53.0	192	26.4	3760	2.1	FH30 2 90B5	FM 90 S4	50
	53.0	192	26.4	4700	2.1	FH35 2 90B5	FM 90 S4	54
	55.8	182	25.08	2700	1.3	FH25 2 90B5	FM 90 S4	46
	57.5	177	48.66	4500	1.1	FH25 3 80B5	FM 80 B2	47

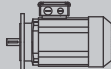

P _{1n} [kW]	n ₂ [r/min]	M _{2n} [Nm]	i	Fr ₂ [N]	f _s			
1.1	58.1	175	48.18	5000	2.2	FH30 3 80B5	FM 80 B2	51
	58.1	175	48.18	6250	2.2	FH35 3 80B5	FM 80 B2	55
	62.0	164	22.59	3520	2.4	FH30 2 90B5	FM 90 S4	50
	62.0	164	22.59	4400	2.4	FH35 2 90B5	FM 90 S4	54
	63.2	161	14.24	2200	1.3	FH25 2 90B5	FM 90 L6	46
	63.8	159	14.1	3120	1.9	FH30 2 90B5	FM 90 L6	50
	63.8	159	14.1	3900	1.9	FH35 2 90B5	FM 90 L6	54
	65.0	156	13.84	1850	1.0	FH20 2 90B5	FM 90 L6	44
	68.8	148	20.36	2500	1.4	FH25 2 90B5	FM 90 S4	46
	72.3	140	38.71	3650	1.3	FH25 2 80B5	FM 80 B2	46
	73.3	138	38.18	4600	2.7	FH30 2 80B5	FM 80 B2	50
	73.3	138	38.18	5750	2.7	FH35 2 80B5	FM 80 B2	54
	73.6	138	12.22	2350	1.3	FH25 2 90B5	FM 90 L6	46
	74.3	137	12.11	2800	2.9	FH30 2 90B5	FM 90 L6	50
	74.3	137	12.11	3500	2.9	FH35 2 90B5	FM 90 L6	54
	76.5	133	18.3	3280	2.9	FH30 2 90B5	FM 90 S4	50
	76.5	133	18.3	4100	2.9	FH35 2 90B5	FM 90 S4	54
	78.5	129	11.47	1650	1.2	FH20 2 90B5	FM 90 L6	44
	79.2	128	17.68	2250	1.5	FH25 2 90B5	FM 90 S4	46
	80.6	126	34.76	3400	1.5	FH25 2 80B5	FM 80 B2	46
	82.8	123	33.82	1900	0.9	FH20 2 80B5	FM 80 B2	44
	87.4	116	10.3	2250	1.4	FH25 2 90B5	FM 90 L6	46
	88.1	115	15.9	1850	1.0	FH20 2 90B5	FM 90 S4	44
	88.3	115	10.19	2720	3.5	FH30 2 90B5	FM 90 L6	50
	88.3	115	10.19	3400	3.5	FH35 2 90B5	FM 90 L6	54
	89.2	114	31.38	4080	3.3	FH30 2 80B5	FM 80 B2	50
	89.2	114	31.38	5100	3.3	FH35 2 80B5	FM 80 B2	54
	91.8	111	30.5	1900	1.0	FH20 2 80B5	FM 80 B2	44
	92.8	109	9.7	1630	1.3	FH20 2 90B5	FM 90 L6	44
	95.7	106	29.27	3000	1.7	FH25 2 80B5	FM 80 B2	46
	98.3	103	14.24	2200	1.7	FH25 2 90B5	FM 90 S4	46
	101.2	100	13.84	1850	1.2	FH20 2 90B5	FM 90 S4	44
	102.0	99	8.82	2250	1.5	FH25 2 90B5	FM 90 L6	46
	106.1	96	26.4	3760	3.8	FH30 2 80B5	FM 80 B2	50
	106.1	96	26.4	4700	3.8	FH35 2 80B5	FM 80 B2	54
	108.2	94	8.32	1600	1.5	FH20 2 90B5	FM 90 L6	44
	110.7	92	25.29	1900	1.2	FH20 2 80B5	FM 80 B2	44
	111.6	91	25.08	2700	2.0	FH25 2 80B5	FM 80 B2	46
	114.6	88	12.22	2350	1.7	FH25 2 90B5	FM 90 S4	46
	122.1	83	11.47	1650	1.3	FH20 2 90B5	FM 90 S4	44

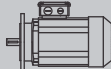

P _{1n} [kW]	n ₂ [r/min]	M _{2n} [Nm]	i	Fr ₂ [N]	f _s			
1.1	124.8	81	7.21	1400	1.6	FH20 2 90B5	FM 90 L6	44
	125.7	81	7.16	2050	1.7	FH25 2 90B5	FM 90 L6	46
	131.0	77	21.38	1900	1.4	FH20 2 80B5	FM 80 B2	44
	135.9	75	10.3	2250	1.8	FH25 2 90B5	FM 90 S4	46
	137.5	74	20.36	2500	2.2	FH25 2 80B5	FM 80 B2	46
	144.3	70	9.7	1630	1.4	FH20 2 90B5	FM 90 S4	44
	144.7	70	6.22	1950	1.8	FH25 2 90B5	FM 90 L6	46
	152.8	66	18.33	1900	1.5	FH20 2 80B5	FM 80 B2	44
	158.4	64	17.68	2250	2.5	FH25 2 80B5	FM 80 B2	46
	158.7	64	8.82	2250	2.0	FH25 2 90B5	FM 90 S4	46
	168.3	60	8.32	1600	1.5	FH20 2 90B5	FM 90 S4	44
	176.1	57	15.9	1850	1.6	FH20 2 80B5	FM 80 B2	44
	179.6	56	5.01	1850	2.0	FH25 2 90B5	FM 90 L6	46
	182.9	55	4.92	790	1.8	FH20 2 90B5	FM 90 L6	44
	194.2	52	7.21	1400	1.7	FH20 2 90B5	FM 90 L6	44
	195.5	52	7.16	2050	2.3	FH25 2 90B5	FM 90 S4	46
	196.6	51	14.24	2200	2.6	FH25 2 80B5	FM 80 B2	46
	202.3	50	13.84	1850	1.8	FH20 2 80B5	FM 80 B2	44
	225.1	45	6.22	1950	2.5	FH25 2 90B5	FM 90 S4	46
	229.1	44	12.22	2350	2.5	FH25 2 80B5	FM 80 B2	46
	244.1	41	11.47	1650	1.9	FH20 2 80B5	FM 80 B2	44
	271.8	37	10.3	2250	2.7	FH25 2 80B5	FM 80 B2	46
	279.4	36	5.01	1850	2.9	FH25 2 90B5	FM 90 S4	46
	284.6	35	4.92	790	2.0	FH20 2 90B5	FM 90 S4	44
	288.7	35	9.7	1630	2.2	FH20 2 80B5	FM 80 B2	44
	317.5	32	8.82	2250	3.0	FH25 2 80B5	FM 80 B2	46
	336.5	30	8.32	1600	2.5	FH20 2 80B5	FM 80 B2	44
	388.3	26	7.21	1400	2.8	FH20 2 80B5	FM 80 B2	44
391.1	26	7.16	2050	3.6	FH25 2 80B5	FM 80 B2	46	
569.1	17	4.92	790	3.7	FH20 2 80B5	FM 80 B2	44	
1.5	8.5	1639	106.22	15000	0.8	FH50 3 100B5	FM 100 L6	59
	10.1	1379	89.35	15000	0.9	FH50 3 100B5	FM 100 L6	59
	10.8	1282	129.23	15000	1.0	FH50 3 90B5	FM 90 L4	59
	11.8	1180	76.45	15000	1.0	FH50 3 100B5	FM 100 L6	59
	13.2	1054	106.22	15000	1.2	FH50 3 90B5	FM 90 L4	59
	14.5	956	61.94	15000	1.3	FH50 3 100B5	FM 100 L6	59
	15.7	886	89.35	15000	1.4	FH50 3 90B5	FM 90 L4	59
	18.2	761	49.32	15000	1.6	FH50 3 100B5	FM 100 L6	59
	18.3	758	76.45	15000	1.7	FH50 3 90B5	FM 90 L4	59

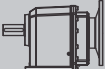
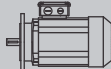

P _{1n} [kW]	n ₂ [r/min]	M _{2n} [Nm]	i	Fr ₂ [N]	f _s			
1.5	21.7	641	129.23	15000	1.5	FH50 3 90B5	FM 90 S2	59
	22.6	614	61.94	15000	2.0	FH50 3 90B5	FM 90 L4	59
	23.6	589	38.18	14500	2.0	FH50 3 100B5	FM 100 L6	59
	26.1	532	107.23	6500	0.8	FH35 3 90B5	FM 90 S2	55
	26.4	527	106.22	15000	1.7	FH50 3 90B5	FM 90 S2	59
	28.4	489	49.32	15000	2.6	FH50 3 90B5	FM 90 L4	59
	28.7	484	31.38	12900	2.4	FH50 2 100B5	FM 100 L6	58
	29.1	478	48.18	5000	0.8	FH30 3 90B5	FM 90 L4	51
	29.1	478	48.18	6250	0.8	FH35 3 90B5	FM 90 L4	55
	31.0	447	90.2	5200	1.0	FH30 3 90B5	FM 90 S2	51
	31.0	447	90.2	6500	1.0	FH35 3 90B5	FM 90 S2	55
	31.3	443	89.35	15000	2.1	FH50 3 90B5	FM 90 S2	59
	34.1	407	26.4	12100	3.0	FH50 2 100B5	FM 100 L6	58
	34.1	407	26.4	3760	0.8	FH30 2 100B5	FM 100 L6	50
	34.1	407	26.4	4700	0.8	FH35 2 100B5	FM 100 L6	54
	36.3	383	77.18	5200	1.1	FH30 3 90B5	FM 90 S2	51
	36.3	383	77.18	6500	1.1	FH35 3 90B5	FM 90 S2	55
	36.6	379	76.45	15000	2.4	FH50 3 90B5	FM 90 S2	59
	36.7	378	38.18	4600	1.1	FH30 3 90B5	FM 90 L4	50
	36.7	378	38.18	5750	1.1	FH35 3 90B5	FM 90 L4	54
	36.7	378	38.18	14500	3.2	FH50 3 90B5	FM 90 L4	59
	39.8	348	22.59	3520	0.9	FH30 2 100B5	FM 100 L6	50
	39.8	348	22.59	4400	0.9	FH35 2 100B5	FM 100 L6	54
	39.8	348	22.59	11200	3.4	FH50 2 100B5	FM 100 L6	58
	44.6	311	31.38	4080	1.3	FH30 2 90B5	FM 90 L4	50
	44.6	311	31.38	5100	1.3	FH35 2 90B5	FM 90 L4	54
	44.8	310	62.53	5200	1.3	FH30 3 90B5	FM 90 S2	51
	44.8	310	62.53	6500	1.3	FH35 3 90B5	FM 90 S2	55
	45.2	307	61.94	15000	2.9	FH50 3 90B5	FM 90 S2	59
	49.2	282	18.3	3280	1.1	FH30 2 100B5	FM 100 L6	50
	49.2	282	18.3	4100	1.1	FH35 2 100B5	FM 100 L6	54
	53.0	262	26.4	3760	1.5	FH30 2 90B5	FM 90 L4	50
	53.0	262	26.4	4700	1.5	FH35 2 90B5	FM 90 L4	54
	55.8	248	25.08	2700	0.90	FH25 2 90B5	FM 90 L4	46
	57.5	241	48.66	4500	0.8	FH25 3 90B5	FM 90 S2	47
	58.1	239	48.18	5000	1.6	FH30 3 90B5	FM 90 S2	51
	58.1	239	48.18	6250	1.6	FH35 3 90B5	FM 90 S2	55
	62.0	224	22.59	3520	1.7	FH30 2 90B5	FM 90 L4	50
	62.0	224	22.59	4400	1.7	FH35 2 90B5	FM 90 L4	54
	63.8	217	14.1	3120	1.4	FH30 2 100B5	FM 100 L6	50

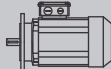

P _{1n} [kW]	n ₂ [r/min]	M _{2n} [Nm]	i	Fr ₂ [N]	f _s			
1.5	63.8	217	14.1	3900	1.4	FH35 2 100B5	FM 100 L6	54
	68.8	202	20.36	2500	1.0	FH25 2 90B5	FM 90 L4	46
	72.3	192	38.71	3650	1.0	FH25 2 90B5	FM 90 S2	46
	73.3	189	38.18	4600	2.0	FH30 2 90B5	FM 90 S2	50
	73.3	189	38.18	5750	2.0	FH35 2 90B5	FM 90 S2	54
	74.3	187	12.11	2800	2.1	FH30 2 100B5	FM 90 L6	50
	74.3	187	12.11	3500	2.1	FH35 2 100B5	FM 100 L6	54
	76.5	181	18.3	3280	2.1	FH30 2 90B5	FM 90 L4	50
	76.5	181	18.3	4100	2.1	FH35 2 90B5	FM 90 L4	54
	79.2	175	17.68	2250	1.1	FH25 2 90B5	FM 90 L4	46
	80.6	172	34.76	3400	1.1	FH25 2 90B5	FM 90 S2	46
	88.3	157	10.19	2720	2.5	FH30 2 100B5	FM 100 L6	50
	88.3	157	10.19	3400	2.5	FH35 2 100B5	FM 100 L6	54
	89.2	155	31.38	4080	2.4	FH30 2 90B5	FM 90 S2	50
	89.2	155	31.38	5100	2.4	FH35 2 90B5	FM 90 S2	54
	95.7	145	29.27	3000	1.3	FH25 2 90B5	FM 90 S2	46
	98.3	141	14.24	2200	1.3	FH25 2 90B5	FM 90 L4	46
	99.3	139	14.1	3120	2.7	FH30 2 90B5	FM 90 L4	50
	99.3	139.9	14.1	3900	2.7	FH35 2 90B5	FM 90 L4	54
	103.2	134	8.72	2680	2.9	FH30 2 100B5	FM 100 L6	50
	103.2	134	8.72	3350	2.9	FH35 2 100B5	FM 100 L6	54
	106.1	131	26.4	3760	2.8	FH30 2 90B5	FM 90 S2	50
	106.1	131	26.4	4700	2.8	FH35 2 90B5	FM 90 S2	54
	111.6	124	25.08	2700	1.5	FH25 2 90B5	FM 90 S2	46
	114.6	121	12.22	2350	1.2	FH25 2 90B5	FM 90 L4	46
	115.6	120	12.11	2800	3.2	FH30 2 90B5	FM 90 L4	50
	115.6	120	12.11	3500	3.2	FH35 2 90B5	FM 90 L4	54
	123.9	112	22.59	3520	3.3	FH30 2 90B5	FM 90 S2	50
	123.9	112	22.59	4400	3.3	FH35 2 90B5	FM 90 S2	54
	127.5	109	7.06	2530	3.5	FH35 2 100B5	FM 100 L6	50
	127.5	109	7.06	3160	3.5	FH35 2 100B5	FM 100 L6	54
	135.9	102	10.3	2250	1.3	FH25 2 90B5	FM 90 L4	46
	137.5	101	20.36	2500	1.7	FH25 2 90B5	FM 90 S2	46
	158.4	87	17.68	2250	1.8	FH25 2 90B5	FM 90 S2	46
158.7	87	8.82	2250	1.5	FH25 2 90B5	FM 90 L4	46	
195.5	71	7.16	2050	1.7	FH25 2 90B5	FM 90 L4	46	
196.6	70	14.24	2200	1.9	FH25 2 90B5	FM 90 S2	46	
225.1	61	6.22	1950	1.9	FH25 2 90B5	FM 90 L4	46	
229.1	60	12.22	2350	1.9	FH25 2 90B5	FM 90 S2	46	
271.8	51	10.3	2250	2.0	FH25 2 90B5	FM 90 S2	46	

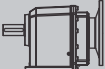
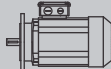

P _{1n} [kW]	n ₂ [r/min]	M _{2n} [Nm]	i	Fr ₂ [N]	f _s			
1.5	279.4	49	5.01	1850	2.1	FH25 2 90B5	FM 90 L4	46
	317.5	43	8.82	2250	2.2	FH25 2 90B5	FM 90 S2	46
	391.1	35	7.16	2050	2.7	FH25 2 90B5	FM 90 S2	46
	450.2	30	6.22	1950	2.9	FH25 2 90B5	FM 90 S2	46
	558.9	24	5.01	1850	3.4	FH25 2 90B5	FM 90 S2	46
2.2	13.2	1546	106.22	15000	0.8	FH50 3 100B5	FM 100 L4	59
	14.5	1402	61.94	15000	0.9	FH50 3 112B5	FM 112 M6	59
	15.7	1300	89.35	15000	1.0	FH50 3 100B5	FM 100 L4	59
	18.2	1116	49.32	15000	1.1	FH50 3 112B5	FM 112 M6	59
	18.3	1112	76.45	15000	1.1	FH50 3 100B5	FM 100 L4	59
	22.6	901	61.94	15000	1.4	FH50 3 100B5	FM 100 L4	59
	21.7	940	129.23	15000	1.0	FH50 3 90B5	FM 90 L2	59
	23.6	864	38.18	14500	1.3	FH50 3 112B5	FM 112 M6	59
	26.4	773	106.22	15000	1.2	FH50 3 90B5	FM 90 L2	59
	28.4	717	49.32	15000	1.8	FH50 3 100B5	FM 100 L4	59
	28.7	710	31.38	12900	1.6	FH50 2 112B5	FM 112 M6	58
	31.3	650	89.35	15000	1.4	FH50 3 90B5	FM 90 L2	59
	34.1	597	26.4	12100	2.0	FH50 3 112B5	FM 112 M6	58
	36.3	561	77.18	5200	0.8	FH30 3 90B5	FM 90 L2	51
	36.3	561	77.18	6500	0.8	FH35 3 90B5	FM 90 L2	55
	36.6	556	76.45	15000	1.6	FH50 3 90B5	FM 90 L2	59
	36.7	555	38.18	14500	2.2	FH50 3 100B5	FM 100 L4	59
	39.8	511	22.59	11200	2.3	FH50 2 112B5	FM 112 M6	58
	44.6	456	31.38	4080	0.9	FH30 2 100B5	FM 100 L4	50
	44.6	456	31.38	5100	0.9	FH35 2 100B5	FM 100 L4	54
	44.6	456	31.38	12900	2.6	FH50 2 100B5	FM 100 L4	58
	44.8	455	62.53	5200	0.9	FH30 3 90B	FM 90 L2	51
	44.8	455	62.53	6500	0.9	FH35 3 90B	FM 90 L2	55
	45.2	450	61.94	15000	2.0	FH50 3 90B	FM 90 L2	59
	49.2	414	18.3	3280	0.8	FH30 2 112B5	FM 112 M6	50
	49.2	414	18.3	4100	0.8	FH35 2 112B5	FM 112 M6	54
	49.2	414	18.3	9900	2.9	FH50 2 112B5	FM 112 M6	58
	53.0	384	26.4	3760	1.0	FH30 2 100B5	FM 100 L4	50
	53.0	384	26.4	4700	1.0	FH35 2 100B5	FM 100 L4	54
	53.0	384	26.4	12100	3.1	FH50 2 100B5	FM 100 L4	58
	56.8	358	49.32	15000	2.5	FH50 3 90B5	FM 90 L2	59
	58.1	350	48.18	5000	1.1	FH30 3 90B5	FM 90 L2	51
	58.1	350	48.18	6250	1.1	FH35 3 90B5	FM 90 L2	55
62.0	328	22.59	3520	1.2	FH30 2 100B5	FM 100 L4	50	

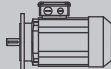

P _{1n} [kW]	n ₂ [r/min]	M _{2n} [Nm]	i	Fr ₂ [N]	f _s			
2.2	62.0	328	22.59	4400	1.2	FH35 2 100B5	FM 100 L4	54
	63.8	319	14.1	3120	1.0	FH30 2 112B5	FM 112 M6	50
	63.8	319	14.1	3900	1.0	FH35 2 112B5	FM 112 M6	54
	73.3	277	38.18	4600	1.4	FH30 2 90B5	FM 90 L2	50
	73.3	277	38.18	5750	1.4	FH35 2 90B5	FM 90 L2	54
	73.3	277	38.18	14500	3.1	FH50 3 90B5	FM 90 L2	59
	74.3	274	12.11	2800	1.5	FH30 2 112B5	FM 112 M6	50
	74.3	274	12.11	3500	1.5	FH35 2 112B5	FM 112 M6	54
	76.5	266	18.3	3280	1.4	FH30 2 100B5	FM 100 L4	50
	76.5	266	18.3	4100	1.4	FH35 2 100B5	FM 100 L4	54
	88.3	230	10.19	2720	1.7	FH30 2 112B5	FM 112 M6	50
	88.3	230	10.19	3400	1.7	FH35 2 112B5	FM 112 M6	54
	89.2	228	31.38	4080	1.6	FH30 2 90B5	FM 90 L2	50
	89.2	228	31.38	5100	1.6	FH35 2 90B5	FM 90 L2	54
	95.7	213	29.27	3000	0.9	FH25 2 90B5	FM 90 L2	46
	99.3	205	14.1	3120	1.8	FH30 2 100B5	FM 100 L4	50
	99.3	205	14.1	3900	1.8	FH35 2 100B5	FM 100 L4	54
	103.2	197	8.72	2680	2.0	FH30 2 112B5	FM 112 M6	50
	103.2	197	8.72	3350	2.0	FH35 2 112B5	FM 112 M6	54
	106.1	192	26.4	3760	1.9	FH30 2 90B5	FM 90 L2	50
	106.1	192	26.4	4700	1.9	FH35 2 90B5	FM 90 L2	54
	111.6	182	25.08	2700	1.0	FH25 2 90B5	FM 90 L2	46
	115.6	176	12.11	2800	2.2	FH30 2 100B5	FM 100 L4	50
	115.6	176	12.11	3500	2.2	FH35 2 100B5	FM 100 L4	54
	123.9	164	22.59	3520	2.2	FH30 2 90B5	FM 90 L2	50
	123.9	164	22.59	4400	2.2	FH35 2 90B5	FM 90 L2	54
	127.5	159	7.06	2530	2.4	FH30 2 112B5	FM 112 M6	50
	127.5	159	7.06	3160	2.4	FH35 2 112B5	FM 112 M6	54
	137.4	148	10.19	2720	2.8	FH30 2 100B5	FM 100 L4	50
	137.4	148	10.19	3400	2.8	FH35 2 100B5	FM 100 L4	54
	137.5	148	20.36	2500	1.2	FH25 2 90B5	FM 90 L2	46
	153.0	133	18.3	3280	2.7	FH30 2 90B5	FM 90 L2	50
	153.0	133	18.3	4100	2.7	FH35 2 90B5	FM 90 L2	54
	158.4	128	17.68	2250	1.2	FH25 2 90B5	FM 90 L2	46
160.6	126	8.72	2680	3.3	FH30 2 100B5	FM 100 L4	50	
160.6	126	8.72	3350	3.3	FH35 2 112B5	FM 100 L4	54	
165.4	123	5.44	2440	3.1	FH30 2 112B5	FM 112 M6	50	
165.4	123	5.44	3050	3.1	FH35 2 112B5	FM 112 M6	54	
196.6	103	14.24	2200	1.3	FH25 2 90B5	FM 90 L2	46	
198.6	102	14.1	3120	3.5	FH30 2 90B5	FM 90 L2	50	

P _{1n} [kW]	n ₂ [r/min]	M _{2n} [Nm]	i	Fr ₂ [N]	f _s			
2.2	198.6	102	14.1	3900	3.5	FH35 2 90B5	FM 90 L2	54
	229.1	88	12.22	2350	1.3	FH25 2 90B5	FM 90 L2	46
	271.8	75	10.3	2250	1.4	FH25 2 90B5	FM 90 L2	46
	317.5	64	8.82	2250	1.5	FH25 2 90B5	FM 90 L2	46
	391.1	52	7.16	2050	1.8	FH25 2 90B5	FM 90 L2	46
	450.2	45	6.22	1950	2.0	FH25 2 90B5	FM 90 L2	46
	558.9	36	5.01	1850	2.3	FH25 2 90B5	FM 90 L2	46
3.7	22.6	1516	61.94	15000	0.8	FH50 3 112B5	FM 112 M4	59
	23.6	1453	38.18	14500	0.8	FH50 3 132B5	FM 132 S6	59
	28.4	1207	49.32	15000	1.0	FH50 3 112B5	FM 112 M4	59
	28.7	1195	31.38	12900	1.0	FH50 2 132B5	FM 132 S6	58
	31.3	1093	89.35	15000	0.8	FH50 3 100B5	FM 100 L2	59
	34.1	1005	26.4	12100	1.2	FH50 2 132B5	FM 132 S6	58
	36.6	935	76.45	15000	1.0	FH50 3 100B5	FM 100 L2	59
	36.7	934	38.18	14500	1.3	FH50 3 112B5	FM 112 M4	59
	39.8	860	22.59	11200	1.4	FH50 2 132B5	FM 132 S6	58
	44.6	768	31.38	12900	1.6	FH50 3 112B5	FM 112 M4	58
	45.2	758	61.94	15000	1.2	FH50 3 100B5	FM 100 L2	59
	49.2	696	18.3	9900	1.7	FH50 2 132B5	FM 132 S6	58
	53.0	646	26.4	12100	1.8	FH50 2 112B5	FM 112 M4	58
	56.8	603	49.32	15000	1.5	FH50 3 100B5	FM 100 L2	59
	61.8	554	14.57	9500	2.6	FH50 3 112B5	FM 132 S6	59
	62.0	553	22.59	11200	2.1	FH50 2 112B5	FM 112 M4	58
	73.3	467	38.18	4600	0.8	FH50 3 100B5	FM 100 L2	59
	73.3	467	38.18	5750	0.8	FH35 2 100B5	FM 100 L2	54
	73.3	467	38.18	14500	1.8	FH50 3 100B5	FM 100 L2	59
	74.3	461	12.11	8800	3.0	FH50 2 132B5	FM 132 M6	58
	76.5	448	18.3	3280	0.9	FH30 2 112B5	FM 112 M4	50
	76.5	448	18.3	4100	0.9	FH35 2 112B5	FM 112 M4	54
	76.5	448	18.3	9900	2.6	FH50 2 112B5	FM 112 M4	58
	88.3	388	10.19	8150	3.3	FH50 2 132B5	FM 132 M6	58
	89.2	384	31.38	4080	1.0	FH30 2 100B5	FM 100 L2	50
	89.2	384	31.38	5100	1.0	FH35 2 100B5	FM 100 L2	54
	89.2	384	31.38	12900	2.2	FH50 2 100B5	FM 100 L2	58
	96.1	356	14.57	9500	3.2	FH50 2 112B5	FM 112 M4	58
	99.3	345	14.1	3120	1.1	FH30 2 112B5	FM 112 M4	50
	99.3	345	14.1	3900	1.1	FH35 2 112B5	FM 112 M4	54
	103.2	332	8.72	7500	4.1	FH50 2 132B5	FM 132 S6	58
106.1	323	26.4	3760	1.1	FH30 2 100B5	FM 100 L2	50	

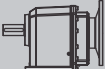
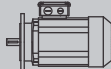
P _{1n} [kW]	n ₂ [r/min]	M _{2n} [Nm]	i	Fr ₂ [N]	f _s				
3.7	106.1	323	26.4	4700	1.1	FH35 2 100B5	FM 100 L2	54	
	106.1	323	26.4	12100	2.6	FH50 2 100B5	FM 100 L2	58	
	115.6	296	12.11	2800	1.3	FH30 2 112B5	FM 112 M4	50	
	115.6	296	12.11	3500	1.3	FH35 2 112B5	FM 112 M4	54	
	123.9	276	22.59	3520	1.3	FH30 2 100B5	FM 100 L2	50	
	123.9	276	22.59	4400	1.3	FH35 2 100B5	FM 100 L2	54	
	123.9	276	22.59	11200	2.9	FH50 2 100B5	FM 100 L2	58	
	137.4	249	10.19	2720	1.6	FH30 2 112B5	FM 112 M4	50	
	137.4	249	10.19	3400	1.6	FH35 2 112B5	FM 112 M4	54	
	153.0	224	18.3	3280	1.6	FH30 2 100B5	FM 100 L2	50	
	153.0	224	18.3	4100	1.6	FH35 2 100B5	FM 100 L2	54	
	160.6	213	8.72	2680	2.0	FH30 2 112B5	FM 112 M4	50	
	160.6	213	8.72	3350	2.0	FH35 2 112B5	FM 112 M4	54	
	192.2	178	14.57	9500	4.3	FH50 2 100B5	FM 100 L2	58	
	198.3	172	7.06	2530	2.4	FH30 2 112B5	FM 112 M4	50	
	198.3	172	7.06	3160	2.4	FH35 2 112B5	FM 112 M4	54	
	198.6	172	14.1	3120	2.1	FH30 2 100B5	FM 100 L2	50	
	198.6	172	14.1	3900	2.1	FH35 2 100B5	FM 100 L2	54	
	231.2	148	12.11	2800	2.5	FH30 2 100B5	FM 100 L2	50	
	231.2	148	12.11	3500	2.5	FH35 2 100B5	FM 100 L2	54	
	257.4	133	5.44	2440	2.5	FH30 2 112B5	FM 112 M4	50	
	257.4	133	5.44	3050	2.5	FH35 2 112B5	FM 112 M4	54	
	274.8	124	10.19	2720	2.8	FH30 2 100B5	FM 100 L2	50	
	274.8	124	10.19	3400	2.8	FH35 2 100B5	FM 100 L2	54	
	321.1	106	8.72	2680	3.0	FH30 2 100B5	FM 100 L2	50	
	321.1	106	8.72	3350	3.0	FH35 2 100B5	FM 100 L2	54	
	396.6	86	7.06	2530	3.4	FH30 2 100B5	FM 100 L2	50	
	396.6	86	7.06	3160	3.4	FH35 2 100B5	FM 100 L2	54	
	5.5	34.1	1494	26.4	12100	0.8	FH50 2 132B5	FM 132 M6	58
		36.7	1389	38.18	14500	0.9	FH50 3 132B5	FM 132 S4	59
39.8		1278	22.59	11200	0.9	FH50 2 132B5	FM 132 M6	58	
44.6		1141	31.38	12900	1.1	FH50 2 132B5	FM 132 S4	58	
45.2		1127	61.94	15000	0.8	FM50 3 112B5 / 132B5	FM 112 M2/FM 132 SA2	59	
49.2		1035	18.3	9900	1.1	FH50 2 132B5	FM 132 M6	58	
53.0		960	26.4	12100	1.2	FH50 2 132B5	FM 132 S4	58	
56.8		897	49.32	15000	1.0	FM50 3 112B5 / 132B5	FM 112 M2/FM 132 SA2	59	
61.8		824	14.57	9500	1.7	FH50 2 132B5	FM 132 M6	58	
62.0		822	22.59	11200	1.4	FH50 2 132B5	FM 132 S4	58	
73.3		694	38.18	14500	1.2	FM50 3 112B5 / 132B5	FM 112 M2/FM 132 SA2	59	

P _{1n} [kW]	n ₂ [r/min]	M _{2n} [Nm]	i	Fr ₂ [N]	f _s			
5.5	74.3	685	12.11	8800	2.0	FH50 2 132B5	FM 132 M6	58
	76.5	665	18.3	9900	1.7	FH50 2 132B5	FM 132 S4	58
	88.3	576	10.19	8150	2.2	FH50 2 132B5	FM 132 M6	58
	89.2	571	31.38	12900	1.5	FM50 2 112B5 / 132B5	FM 112 M2/FM 132 SA2	58
	96.1	530	14.57	9500	2.2	FH50 2 132B5	FM 132 S4	58
	103.2	493	8.72	7500	2.7	FH50 2 132B5	FM 132 M6	58
	106.1	480	26.4	12100	1.7	FM50 2 112B5 / 132B5	FM 112 M2/FM 132 SA2	58
	115.6	440	12.11	8800	2.8	FH50 2 132B5	FM 132 S4	58
	123.9	411	22.59	11200	2.0	FM50 2 112B5 / 132B5	FM 112 M2/FM 132 SA2	58
	127.5	399	7.06	7100	2.8	FH50 2 132B5	FM 132 M6	58
	137.4	370	10.19	8150	3.5	FH50 2 132B5	FM 132 S4	58
	153.0	333	18.3	9900	2.4	FM50 2 112B5 / 132B5	FM 112 M2/FM 132 SA2	58
	160.1	318	5.62	7050	3.3	FH50 2 132B5	FM 132 M6	58
	192.2	265	14.57	9500	2.9	FM50 2 112B5 / 132B5	FM 112 M2/FM 132 SA2	58
	231.2	220	12.11	8800	3.3	FM50 2 112B5 / 132B5	FM 112 M2/FM 132 SA2	58
	7.5	44.6	1557	31.38	12900	0.8	FH50 2 132B5	FM 132 MA4
49.2		1412	18.3	9900	0.8	FH50 2 160B5	FM 160 M6	58
53.0		1310	26.4	12100	0.9	FH50 2 132B5	FM 132 MA4	58
61.8		1124	14.57	9500	1.3	FH50 2 160B5	FM 160 M6	58
62.0		1121	22.59	11200	1.0	FH50 2 132B5	FM 132 MA4	58
73.3		947	38.18	14500	0.9	FH50 2 132B5	FM 132 S2	59
74.3		934	12.11	8800	1.5	FH50 2 160B5	FM 160 M6	58
76.5		908	18.3	9900	1.3	FH50 2 132B5	FM 132 MA4	58
88.3		786	10.19	8150	1.6	FH50 2 160B5	FM 160 M6	58
89.2		778	31.38	12900	1.1	FH50 2 132B5	FM 132 S2	58
96.1		723	14.57	9500	1.6	FH50 2 132B5	FM 132 MA4	58
103.2		673	8.72	7500	2.0	FH50 2 160B5	FM 160 M6	58
106.1		655	26.4	12100	1.3	FH50 2 132B5	FM 132 S2	58
115.6		600	12.11	8800	2.0	FH50 2 132B5	FM 132 MA4	58
123.9		560	22.59	11200	1.5	FH50 2 132B5	FM 132 S2	58
127.5		545	7.06	7100	2.0	FH50 2 160B5	FM 160 M6	58
137.4		505	10.19	8150	2.5	FH50 2 132B5	FM 132 MA4	58
153.0		454	18.3	9900	1.8	FH50 2 132B5	FM 132 S2	58
160.1		433	5.62	7050	2.4	FH50 2 160B5	FM 160 M6	58
160.6		432	8.72	7500	3.1	FH50 2 132B5	FM 132 MA4	58
192.2		361	14.57	9500	2.1	FH50 2 132B5	FM 132 S2	58
198.3		350	7.06	7100	3.3	FH50 2 132B5	FM 132 MA4	58
231.2		300	12.11	8800	2.4	FH50 2 132B5	FM 132 S2	58
249.1		278	5.62	7050	3.5	FH50 2 132B5	FM 132 MA4	58
274.8	252	10.19	8150	2.8	FH50 2 132B5	FM 132 S2	58	

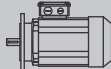
P _{1n} [kW]	n ₂ [r/min]	M _{2n} [Nm]	i	Fr ₂ [N]	f _s			
9.3	62.0	1390	22.59	11200	0.8	FH50 2 132B5/160B5	FM 132 MB4/FM 160MA4	58
	76.5	1126	18.3	9900	1.0	FH50 2 132B5/160B5	FM 132 MB4/FM 160MA4	58
	89.2	965	31.38	12900	0.9	FH50 2 132B5	FM 132 M2	58
	96.1	896	14.57	9500	1.3	FH50 2 132B5/160B5	FM 132 MB4/FM 160MA4	58
	106.1	812	26.4	12100	1.0	FH50 2 132B5	FM 132 M2	58
	115.6	745	12.11	8800	1.6	FH50 2 132B5/160B5	FM 132 MB4/FM 160MA4	58
	123.9	695	22.59	11200	1.2	FH50 2 132B5	FM 132 M2	58
	137.4	627	10.19	8150	2.0	FH50 2 132B5/160B5	FM 132 MB4/FM 160MA4	58
	153.0	563	18.3	9900	1.4	FH50 2 132B5	FM 132 M2	58
	160.6	536	8.72	7500	2.5	FH50 2 132B5/160B5	FM 132 MB4/FM 160MA4	58
	192.2	448	14.57	9500	1.7	FH50 2 132B5	FM 132 M2	58
	198.3	434	7.06	7100	2.7	FH50 2 132B5/160B5	FM 132 MB4/FM 160MA4	58
	231.2	372	12.11	8800	1.9	FH50 2 132B5	FM 132 M2	58
	249.1	345	5.62	7050	2.8	FH50 2 132B5/160B5	FM 132 MB4/FM 160MA4	58
	274.8	313	10.19	8150	2.3	FH50 2 132B5	FM 132 M2	58
	321.1	268	8.72	7500	2.9	FH50 2 132B5	FM 132 M2	58
	396.6	217	7.06	7100	3.2	FH50 2 132B5	FM 132 M2	58
11	61.8	1649	14.57	9500	0.9	FH50 2 160B5	FM 160L6	58
	74.3	1371	12.11	8800	1.0	FH50 2 160B5	FM 160L6	58
	76.5	1331	18.3	9900	0.9	FH50 2 160B5	FM 160M 4	58
	88.3	1153	10.19	8150	1.1	FH50 2 160B5	FM 160L6	58
	96.1	1060	14.57	9500	1.1	FH50 2 160B5	FM 160M 4	58
	103.2	987	8.72	7500	1.4	FH50 2 160B5	FM 160L6	58
	106.1	960	26.4	12100	0.9	FH50 2 160B5	FM 160MA2	58
	115.6	881	12.11	8800	1.4	FH50 2 160B5	FM 160M 4	58
	123.9	822	22.59	11200	1.0	FH50 2 160B5	FM 160MA2	58
	127.5	799	7.06	7100	1.4	FH50 2 160B5	FM 160L6	58
	137.4	741	10.19	8150	1.7	FH50 2 160B5	FM 160M 4	58
	153.0	665	18.3	9900	1.2	FH50 2 160B5	FM 160MA2	58
	160.1	636	5.62	7050	1.6	FH50 2 160B5	FM 160L6	58
	160.6	634	8.72	7500	2.1	FH50 2 160B5	FM 160M 4	58
	192.2	530	14.57	9500	1.5	FH50 2 160B5	FM 160MA2	58
	198.3	513	7.06	7100	2.3	FH50 2 160B5	FM 160M 4	58
	231.2	440	12.11	8800	1.6	FH50 2 160B5	FM 160MA2	58
	249.1	409	5.62	7050	2.4	FH50 2 160B5	FM 160M 4	58
	274.8	370	10.19	8150	1.9	FH50 2 160B5	FM 160MA2	58
	321.1	317	8.72	7500	2.5	FH50 2 160B5	FM 160MA2	58
396.6	256	7.06	7100	2.7	FH50 2 160B5	FM 160MA2	58	
498.2	204	5.62	7050	3.0	FH50 2 160B5	FM 160MA2	58	

P _{1n} [kW]	n ₂ [r/min]	M _{2n} [Nm]	i	Fr ₂ [N]	f _s			
15	96.1	1446	14.57	9500	0.8	FH50 2 160B5	FM 160 L4	58
	115.6	1201	12.11	8800	1.0	FH50 2 160B5	FM 160 L4	58
	137.4	1011	10.19	8150	1.3	FH50 2 160B5	FM 160 L4	58
	153.0	908	18.3	9900	0.9	FH50 2 160B5	FM 160MB2	58
	160.6	865	8.72	7500	1.5	FH50 2 160B5	FM 160 L4	58
	192.2	723	14.57	9500	1.1	FH50 2 160B5	FM 160MB2	58
	198.3	700	7.06	7100	1.7	FH50 2 160B5	FM 160 L4	58
	231.2	600	12.11	8800	1.2	FH50 2 160B5	FM 160MB2	58
	249.1	557	5.62	7050	1.7	FH50 2 160B5	FM 160 L4	58
	274.8	505	10.19	8150	1.4	FH50 2 160B5	FM 160MB2	58
	321.1	432	8.72	7500	1.8	FH50 2 160B5	FM 160MB2	58
	396.6	350	7.06	7100	2.0	FH50 2 160B5	FM 160MB2	58
	498.2	278	5.62	7050	2.2	FH50 2 160B5	FM 160MB2	58

13.2 FH..ISS.. Performance Parameter

FH 20												120 Nm
	i	n ₁ =2800[r/min]					n ₁ =1400[r/min]					
		n ₂ [r/min]	Mn ₂ Nm	Pn ₁ kW	Rn ₁ N	Rn ₂ N	n ₂ [r/min]	Mn ₂ Nm	Pn ₁ kW	Rn ₁ N	Rn ₂ N	
FH20 2	4.92	569.0	67	4.1	700	630	284.5	72	2.2	870	790	45
FH20 2	7.21	388.1	74	3.1	1100	1200	194.1	91	1.9	1250	1400	45
FH20 2	8.32	336.6	76	2.78	1120	1250	168.3	94	1.7	1300	1600	45
FH20 2	9.70	288.7	77	2.4	1140	1280	144.4	96	1.5	1300	1630	45
FH20 2	11.47	244.1	78	2.06	1140	1280	122.0	106	1.4	1300	1650	45
FH20 2	13.84	202.3	91	1.98	1150	1300	101.2	119	1.3	1300	1800	45
FH20 2	15.90	176.1	93	1.76	1150	1300	88.1	119	1.13	1300	1850	45
FH20 2	18.33	152.7	97	1.6	1150	1350	76.4	106	0.87	1300	1900	45
FH20 2	21.38	131.0	108	1.53	1150	1900	65.5	106	0.75	1300	1900	45
FH20 2	25.29	110.7	110	1.31	1150	1900	55.4	107	0.64	1300	1900	45
FH20 2	30.50	91.8	111	1.1	1100	1900	45.9	109	0.54	1300	1900	45
FH20 2	33.82	82.8	112	1	1100	1900	41.4	110	0.49	1300	1900	45
FH20 2	42.67	65.6	113	0.8	1100	1900	32.8	113	0.4	1300	1900	45
		n ₁ =900[r/min]					n ₁ =500[r/min]					
FH20 2	4.92	182.89	101	2	920	890	101.6	120	1.6	1050	950	45
FH20 2	7.21	124.76	120	1.8	1050	1450	69.3	120	1.14	1050	1250	45
FH20 2	8.32	108.20	120	1.6	1100	1250	60.1	120	1	1100	1250	45
FH20 2	9.70	92.80	120	1.38	1100	1280	51.6	120	0.86	1100	1320	45
FH20 2	11.47	78.45	120	1.28	1100	1280	43.6	120	0.73	1100	1320	45
FH20 2	13.84	65.04	120	1.07	1100	1300	36.1	120	0.61	1100	1350	45
FH20 2	15.90	56.60	115	0.7	1100	1300	31.4	120	0.4	1100	1600	45
FH20 2	18.33	49.09	117	0.62	1100	1900	27.3	120	0.36	1100	1900	45
FH20 2	21.38	42.11	117	0.53	1100	1900	23.4	120	0.31	1100	1900	45
FH20 2	25.29	35.59	120	0.46	1100	1900	19.8	120	0.26	1100	1900	45
FH20 2	30.50	29.51	119	0.38	1100	1900	16.4	120	0.22	1100	1900	45
FH20 2	33.82	26.61	120	0.35	1100	1900	14.8	120	0.2	1100	1900	45
FH20 2	42.67	21.09	120	0.28	1100	1900	11.7	120	0.16	1100	1900	45

FH 25												250 Nm
	i	n ₁ =2800[r/min]					n ₁ =1400[r/min]					
		n ₂ [r/min]	Mn ₂ Nm	Pn ₁ kW	Rn ₁ N	Rn ₂ N	n ₂ [r/min]	Mn ₂ Nm	Pn ₁ kW	Rn ₁ N	Rn ₂ N	
FH25 2	5.01	559.0	85	5.1	1000	1350	279.49	106	3.2	1100	1850	48
FH25 2	6.22	450.4	88	4.3	1100	1520	225.19	117	2.85	1150	1950	48
FH25 2	7.16	391.0	95	4	1100	1600	195.48	118	2.5	1450	2050	48
FH25 2	8.82	317.4	96	3.3	1150	1650	158.72	127	2.18	1300	2200	48
FH25 2	10.30	272.0	102	3	1100	1720	135.99	136	2	1250	2250	48



FH..ISS.. Performance Parameter

FH 25		250 Nm										
	i	n ₁ =2800[r/min]					n ₁ =1400[r/min]					
		n ₂ [r/min]	Mn ₂ Nm	Pn ₁ kW	Rn ₁ N	Rn ₂ N	n ₂ [r/min]	Mn ₂ Nm	Pn ₁ kW	Rn ₁ N	Rn ₂ N	
FH25 2	12.22	229.1	113	2.8	1150	1850	114.53	147	1.82	1450	2350	48
FH25 2	14.24	196.6	133	2.82	1150	1850	98.30	179	1.9	1000	2200	48
FH25 2	17.68	158.4	161	2.76	1100	1900	79.20	199	1.7	1000	2250	48
FH25 2	20.36	137.5	176	2.61	1100	2250	68.75	202	1.5	1200	2500	48
FH25 2	25.08	111.6	183	2.2	1050	2350	55.82	236	1.42	1200	2700	48
FH25 2	29.27	95.7	184	1.9	1050	2500	47.83	232	1.2	1250	3000	48
FH25 2	34.76	80.6	187	1.63	1050	2600	40.28	241	1.05	1050	3400	48
FH25 2	38.71	72.3	188	1.47	1050	2800	36.16	243	0.95	1250	3650	48
FH25 2	48.66	57.5	192	1.19	1550	3350	28.77	245	0.76	1550	4500	49
FH25 2	60.40	46.4	194	0.97	1550	3500	23.18	250	0.64	1550	4500	49
FH25 2	69.58	40.2	196	0.85	1550	3850	20.12	250	0.55	1550	4500	49
FH25 3	85.69	32.7	198	0.7	1550	3900	16.34	250	0.45	1550	4500	49
FH25 3	100.02	28.0	202	0.61	1550	4100	14.00	250	0.39	1550	4500	49
FH25 3	118.75	23.6	204	0.52	1550	4500	11.79	250	0.33	1550	4500	49
FH25 3	132.27	21.2	214	0.49	1550	4500	10.58	250	0.3	1550	4500	49
		n ₁ =900[r/min]					n ₁ =500[r/min]					
FH25 2	5.01	179.7	113	2.2	1100	2100	99.8	111	1.2	1100	2500	48
FH25 2	6.22	144.8	125	1.95	1150	2150	80.4	127	1.1	1100	2650	48
FH25 2	7.16	125.7	140	1.9	1550	2250	69.8	133	1	1100	2750	48
FH25 2	8.82	102.0	150	1.65	1400	2500	56.7	160	0.98	1560	2800	48
FH25 2	10.30	87.4	159	1.5	1550	2600	48.6	172	0.9	1600	3100	48
FH25 2	12.22	73.6	176	1.4	1350	2700	40.9	170	0.75	1650	3400	48
FH25 2	14.24	63.2	213	1.45	1350	2700	35.1	198	0.75	1650	3600	48
FH25 2	17.68	50.9	237	1.3	1450	2850	28.3	200	0.61	1650	4100	48
FH25 2	20.36	44.2	220	1.05	1450	3050	24.6	204	0.54	1650	4500	48
FH25 2	25.08	35.9	219	0.85	1550	3550	19.9	204	0.44	1650	4500	48
FH25 2	29.27	30.7	199	0.66	1550	3850	17.1	206	0.38	1650	4500	48
FH25 2	34.76	25.9	204	0.57	1550	4000	14.4	212	0.33	1650	4500	48
FH25 2	38.71	23.2	203	0.51	1550	4150	12.9	208	0.29	1650	4500	48
FH25 3	48.66	18.5	205	0.41	1550	4500	10.3	216	0.24	1550	4500	49
FH25 3	60.40	14.9	211	0.34	1550	4500	8.3	213	0.19	1550	4500	49
FH25 3	69.58	12.9	208	0.29	1550	4500	7.2	219	0.17	1550	4500	49
FH25 3	85.69	10.5	212	0.24	1550	4500	5.8	222	0.14	1550	4500	49
FH25 3	100.02	9.0	216	0.21	1550	4500	5.0	222	0.12	1550	4500	49
FH25 3	118.75	7.6	220	0.18	1550	4500	4.2	220	0.1	1550	4500	49
FH25 3	132.27	6.8	218	0.16	1550	4500	3.8	221	0.09	1550	4500	49



FH..ISS.. Performance Parameter

FH 30		300 Nm										
	i	n ₁ =2800[r/min]					n ₁ =1400[r/min]					
		n ₂ [r/min]	Mn ₂ Nm	Pn ₁ kW	Rn ₁ N	Rn ₂ N	n ₂ [r/min]	Mn ₂ Nm	Pn ₁ kW	Rn ₁ N	Rn ₂ N	
FH30 2	5.44	514.5	252	14	1100	2440	257.3	331	9.2	1950	2440	52
FH30 2	7.06	396.4	294	12.6	1550	2530	198.2	411	8.8	2350	2530	52
FH30 2	8.72	321.2	323	11.2	1800	2680	160.6	421	7.3	2350	2680	52
FH30 2	10.19	274.8	354	10.5	1800	2720	137.4	411	6.09	2400	2720	52
FH30 2	12.11	231.1	373	9.3	1850	2800	115.6	387	4.83	2410	2800	52
FH30 2	14.10	198.6	355	7.6	1900	3120	99.3	379	4.06	2500	3120	52
FH30 2	18.30	153.0	357	5.9	1850	3280	76.5	385	3.18	2900	3280	52
FH30 2	22.59	124.0	366	4.9	2350	3520	62.0	390	2.61	2970	3520	52
FH30 2	26.40	106.1	367	4.2	2350	3760	53.0	395	2.26	2980	3760	52
FH30 2	31.38	89.2	374	3.6	2350	4080	44.6	399	1.92	2990	4080	52
FH30 2	38.18	73.3	379	3	2350	4600	36.7	399	1.58	2990	4600	52
FH30 3	48.18	58.1	382	2.4	2350	5000	29.1	405	1.27	3000	5000	53
FH30 3	62.53	44.8	414	2	2350	5200	22.4	410	0.99	3000	5200	53
FH30 3	77.18	36.3	434	1.7	2350	5200	18.1	414	0.81	3000	5200	53
FH30 3	90.20	31.0	433	1.45	2350	5200	15.5	418	0.7	3000	5200	53
FH30 3	107.23	26.1	426	1.2	2350	5200	13.1	419	0.59	3000	5200	53
FH30 3	130.45	21.5	450	1.05	2350	5200	10.7	440	0.51	3000	5200	53
		n ₁ =900[r/min]					n ₁ =500[r/min]					
FH30 2	5.44	165.4	381	6.8	2500	2440	92	396	3.93	3000	2440	52
FH30 2	7.06	127.4	385	5.3	2900	2530	71	403	3.08	3000	2530	52
FH30 2	8.72	103.2	392	4.37	2880	2680	57	409	2.53	3000	2680	52
FH30 2	10.19	88.3	399	3.8	2950	2720	49	413	2.19	3000	2720	52
FH30 2	12.11	74.3	401	3.22	2950	2800	41	417	1.86	3000	2800	52
FH30 2	14.10	63.8	305	2.1	2950	3120	35	313	1.2	3000	3120	52
FH30 2	18.30	49.2	311	1.65	2950	3280	27	322	0.95	3000	3280	52
FH30 2	22.59	39.8	314	1.35	3000	3520	22	326	0.78	3000	3520	52
FH30 2	26.40	34.1	321	1.18	3000	3760	19	342	0.7	3000	3760	52
FH30 2	31.38	28.7	323	1	3000	4080	16	337	0.58	3000	4080	52
FH30 2	38.18	23.6	373	0.95	3000	4600	13	368	0.52	3000	4600	52
FH30 3	48.18	18.7	446	0.9	3000	5000	10	446	0.5	3000	5000	53
FH30 3	62.53	14.4	444	0.69	3000	5200	8	450	0.4	3000	5200	53
FH30 3	77.18	11.7	450	0.6	3000	5200	6	450	0.35	3000	5200	53
FH30 3	90.20	10.0	450	0.52	3000	5200	6	450	0.3	3000	5200	53
FH30 3	107.23	8.4	450	0.44	3000	5200	5	450	0.26	3000	5200	53
FH30 3	130.45	6.9	450	0.37	3000	5200	4	450	0.21	3000	5200	53

FH..ISS.. Performance Parameter

FH 35		450 Nm										
	i	n ₁ =2800[r/min]					n ₁ =1400[r/min]					
		n ₂ [r/min]	Mn ₂ Nm	Pn ₁ kW	Rn ₁ N	Rn ₂ N	n ₂ [r/min]	Mn ₂ Nm	Pn ₁ kW	Rn ₁ N	Rn ₂ N	
FH35 2	5.44	514.5	252	14	1100	2350	257.3	331	9.2	1950	3050	56
FH35 2	7.06	396.4	294	12.6	1550	2350	198.2	411	8.8	2350	3160	56
FH35 2	8.72	321.2	323	11.2	1800	2350	160.6	421	7.3	2350	3350	56
FH35 2	10.19	274.8	354	10.5	1800	2350	137.4	411	6.09	2400	3400	56
FH35 2	12.11	231.1	373	9.3	1850	2450	115.6	387	4.83	2410	3500	56
FH35 2	14.10	198.6	355	7.6	1900	2550	99.3	379	4.06	2500	3900	56
FH35 2	18.30	153.0	357	5.9	1850	2880	76.5	385	3.18	2900	4100	56
FH35 2	22.59	124.0	366	4.9	2350	3600	62.0	390	2.61	2970	4400	56
FH35 2	26.40	106.1	367	4.2	2350	3850	53.0	395	2.26	2980	4700	56
FH35 2	31.38	89.2	374	3.6	2350	4200	44.6	399	1.92	2990	5100	56
FH35 2	38.18	73.3	379	3	2350	4300	36.7	399	1.58	2990	5750	56
FH35 3	48.18	58.1	382	2.4	2350	4700	29.1	405	1.27	3000	6250	57
FH35 3	62.53	44.8	414	2	2350	5250	22.4	410	0.99	3000	6500	57
FH35 3	77.18	36.3	434	1.7	2350	5850	18.1	414	0.81	3000	6500	57
FH35 3	90.20	31.0	433	1.45	2350	6200	15.5	418	0.7	3000	6500	57
FH35 3	107.23	26.1	426	1.2	2350	6500	13.1	419	0.59	3000	6500	57
FH35 3	130.45	21.5	450	1.05	2350	6500	10.7	440	0.51	3000	6500	57
		n ₁ =900[r/min]					n ₁ =500[r/min]					
FH35 2	5.44	165.4	381	6.8	2500	3600	91.9	396	3.93	3000	3400	56
FH35 2	7.06	127.4	385	5.3	2900	4400	70.8	403	3.08	3000	3600	56
FH35 2	8.72	103.2	392	4.37	2880	4600	57.4	409	2.53	3000	3600	56
FH35 2	10.19	88.3	399	3.8	2950	4700	49.1	413	2.19	3000	3810	56
FH35 2	12.11	74.3	401	3.22	2950	5200	41.3	417	1.86	3000	3850	56
FH35 2	14.10	63.8	305	2.1	2950	5500	35.5	313	1.2	3000	4150	56
FH35 2	18.30	49.2	311	1.65	2950	5700	27.3	322	0.95	3000	4500	56
FH35 2	22.59	39.8	314	1.35	3000	6500	22.1	326	0.78	3000	5250	56
FH35 2	26.40	34.1	321	1.18	3000	6500	18.9	342	0.7	3000	6500	56
FH35 2	31.38	28.7	323	1	3000	6500	15.9	337	0.58	3000	6500	56
FH35 2	38.18	23.6	373	0.95	3000	6500	13.1	368	0.52	3000	6500	56
FH35 3	48.18	18.7	446	0.9	3000	6500	10.4	446	0.5	3000	6500	57
FH35 3	62.53	14.4	444	0.69	3000	6500	8.0	450	0.4	3000	6500	57
FH35 3	77.18	11.7	450	0.6	3000	6500	6.5	450	0.35	3000	6500	57
FH35 3	90.20	10.0	450	0.52	3000	6500	5.5	450	0.3	3000	6500	57
FH35 3	107.23	8.4	450	0.44	3000	6500	4.7	450	0.26	3000	6500	57
FH35 3	130.45	6.9	450	0.37	3000	6500	3.8	450	0.21	3000	6500	57

FH..ISS.. Performance Parameter

FH 50		1300 Nm										
	i	n ₁ =2800[r/min]					n ₁ =1400[r/min]					
		n ₂ [r/min]	Mn ₂ Nm	Pn ₁ kW	Rn ₁ N	Rn ₂ N	n ₂ [r/min]	Mn ₂ Nm	Pn ₁ kW	Rn ₁ N	Rn ₂ N	
FH50 2	5.62	497.9	614	33	2500	6050	248.9	967	26	2150	7050	60
FH50 2	7.06	396.4	701	30	2500	6100	198.2	1168	25	2750	7100	60
FH50 2	8.72	321.2	779	27	2500	6200	160.6	1327	23	2950	7500	60
FH50 2	10.19	274.8	708	21	2540	6200	137.4	1281	19	3400	8150	60
FH50 2	12.11	231.1	721	18	2700	6400	115.6	1218	15.2	3510	8800	60
FH50 2	14.57	192.2	771	16	2810	7200	96.1	1157	12	3600	9500	60
FH50 2	18.30	153.0	799	13.2	2900	7600	76.5	1156	9.55	3700	9900	60
FH50 2	22.59	124.0	815	10.9	3000	8650	62.0	1173	7.85	3900	11200	60
FH50 2	26.40	106.1	830	9.5	3200	9250	53.0	1184	6.78	3990	12100	60
FH50 2	31.38	89.2	841	8.1	3600	9550	44.6	1200	5.78	4100	12900	60
FH50 2	38.18	73.3	859	6.8	3710	11000	36.7	1213	4.8	4150	14500	60
FH50 3	49.32	56.8	881	5.4	3800	12100	28.4	1260	3.86	4700	15000	61
FH50 3	61.94	45.2	881	4.3	3820	13000	22.6	1250	3.05	4700	15000	61
FH50 3	76.45	36.6	910	3.6	3840	14100	18.3	1265	2.5	4700	15000	61
FH50 3	89.35	31.3	916	3.1	3850	15000	15.7	1277	2.16	4700	15000	61
FH50 3	106.22	26.4	921	2.62	3800	15000	13.2	1286	1.83	4700	15000	61
FH50 3	129.23	21.7	932	2.18	3800	15000	10.8	1300	1.52	4700	15000	61
		n ₁ =900[r/min]					n ₁ =500[r/min]					
FH50 2	5.62	160.0	1042	18	3950	9300	88.9	1157	11.1	4150	9900	60
FH50 2	7.06	127.4	1105	15.2	3980	8100	70.8	1125	8.6	4280	10200	60
FH50 2	8.72	103.2	1355	15.1	4060	9200	57.4	1098	6.8	4700	12300	60
FH50 2	10.19	88.3	1269	12.1	4280	9700	49.1	1170	6.2	4700	12900	60
FH50 2	12.11	74.3	1396	11.2	4420	10600	41.3	1189	5.3	4700	14200	60
FH50 2	14.57	61.8	1425	9.5	4430	11500	34.3	1188	4.4	4700	15000	60
FH50 2	18.30	49.2	1187	6.3	4590	12700	27.3	1288	3.8	4700	15000	60
FH50 2	22.59	39.8	1186	5.1	4700	14300	22.1	1297	3.1	4700	15000	60
FH50 2	26.40	34.1	1223	4.5	4700	15000	18.9	1272	2.6	4700	15000	60
FH50 2	31.38	28.7	1163	3.6	4700	15000	15.9	1192	2.05	4700	15000	60
FH50 2	38.18	23.6	1159	2.95	4700	15000	13.1	1217	1.72	4700	15000	60
FH50 3	49.32	18.2	1193	2.35	4700	15000	10.1	1224	1.34	4700	15000	61
FH50 3	61.94	14.5	1198	1.88	4700	15000	8.1	1228	1.07	4700	15000	61
FH50 3	76.45	11.8	1227	1.56	4700	15000	6.5	1246	0.88	4700	15000	61
FH50 3	89.35	10.1	1223	1.33	4700	15000	5.6	1275	0.77	4700	15000	61
FH50 3	106.22	8.5	1246	1.14	4700	15000	4.7	1279	0.65	4700	15000	61
FH50 3	129.23	7.0	1264	0.95	4700	15000	3.9	1293	0.54	4700	15000	61

14. OUT LINE DIMENSIONS

FH20 - 2 - - - IEC

F

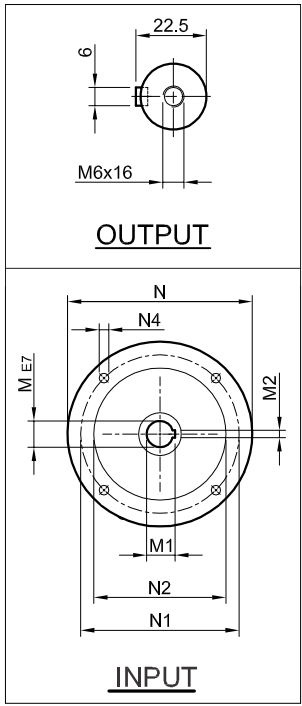
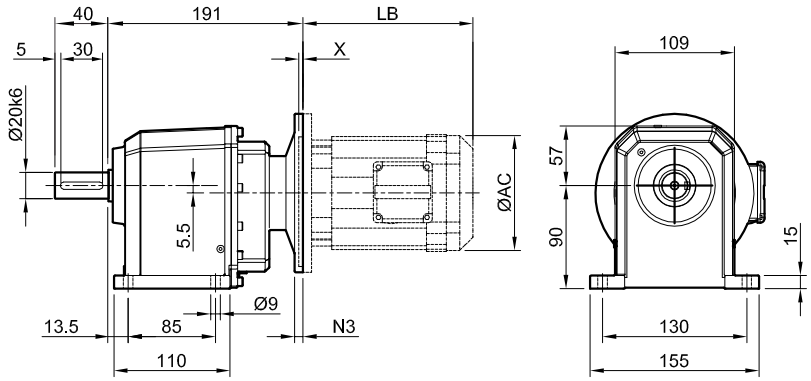

FL

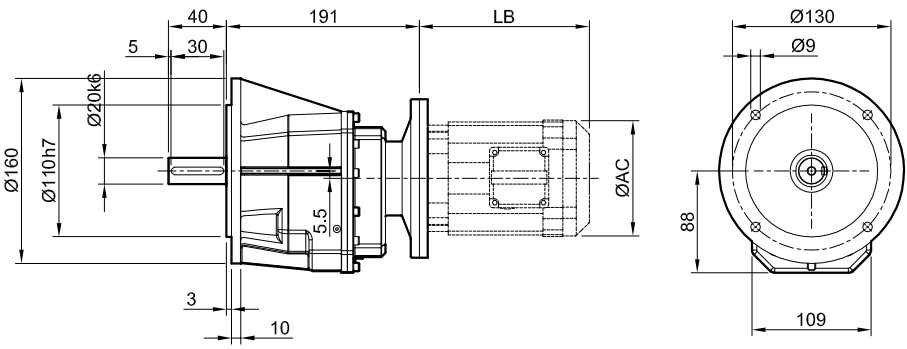

Motor Type	IEC	M	M2	M1	N	N1	N2	N3	N4	X	FM		FM - DCB	
											LB	AC	LB	AC
FH20-2	F63	11	4	12.8	140	115	95		9	5	184	120	247	120
FH20-2	F71	14	5	16.3	160	130	110	-	9	5	201	140	258	140
FH20-2	F80	19	6	21.8	200	165	130	-	11	5	227	156	290	156
FH20-2	F90	24	8	27.3	200	165	130	-	11	5	272	172	322	172

FH20 - 2 - - - ISS

F

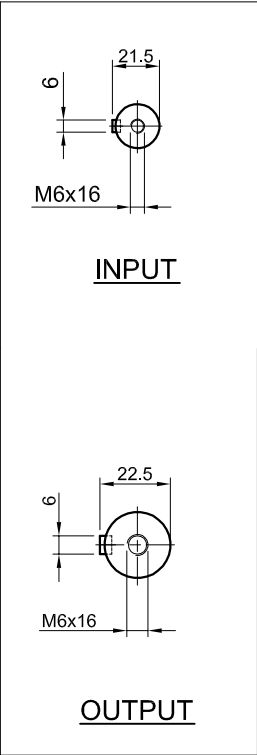
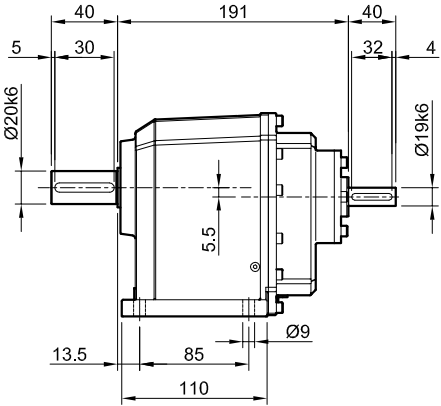

FL

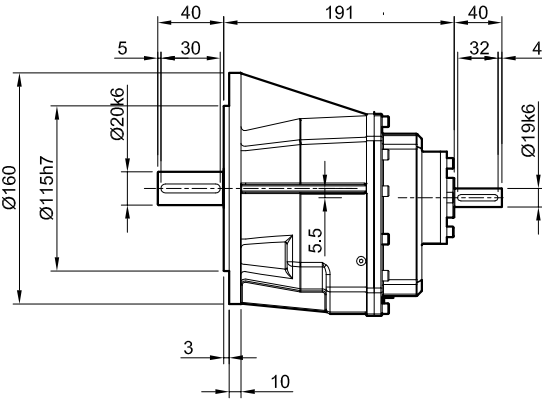

FH25 - 2 - - - IEC

F

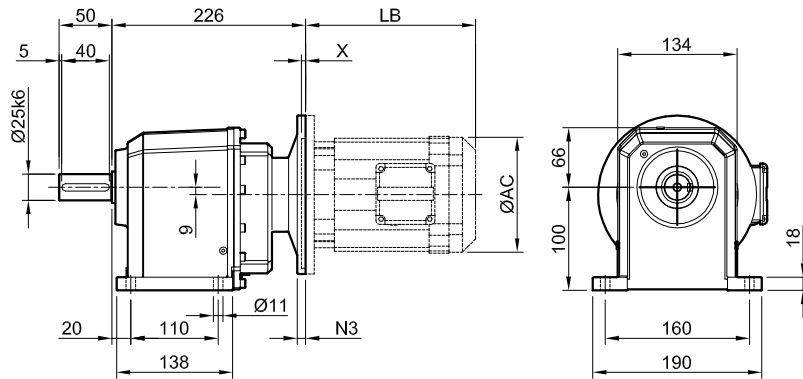

FL

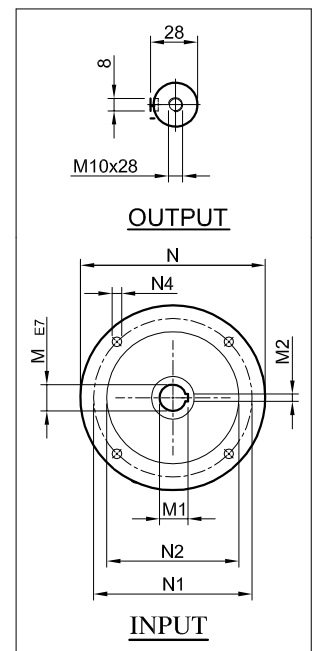
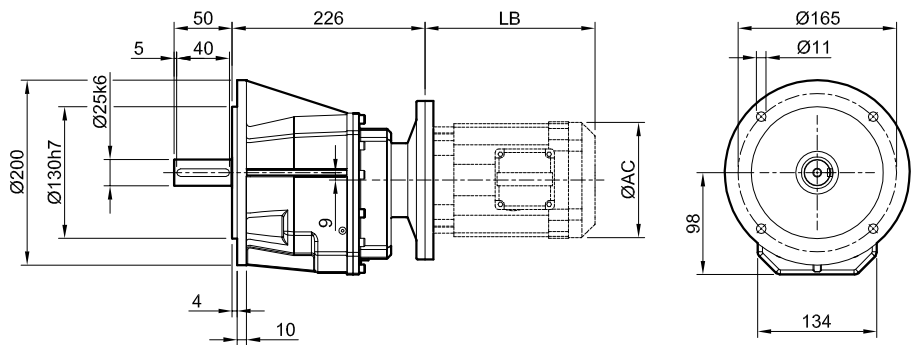

	IEC	M	M2	M1	N	N1	N2	N3	N4	X	FM		FM - DCB	
											LB	AC	LB	AC
FH25-2	F63	11	4	12.8	140	115	95		9	5	184	120	247	120
FH25-2	F71	14	5	16.3	160	130	110	-	9	5	201	140	258	140
FH25-2	F80	19	6	21.8	200	165	130	-	11	5	227	156	290	156
FH25-2	F90	24	8	27.3	200	165	130	-	11	5	272	172	322	172

FH25 - 3 - - - IEC

F

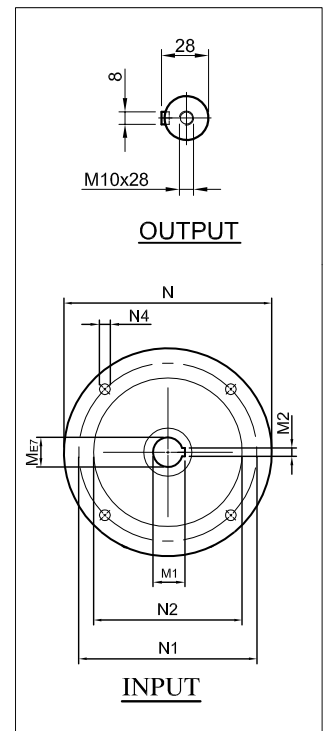
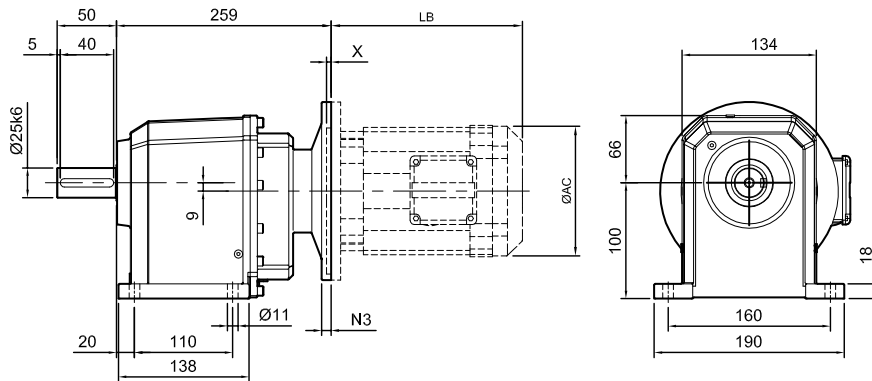

FL

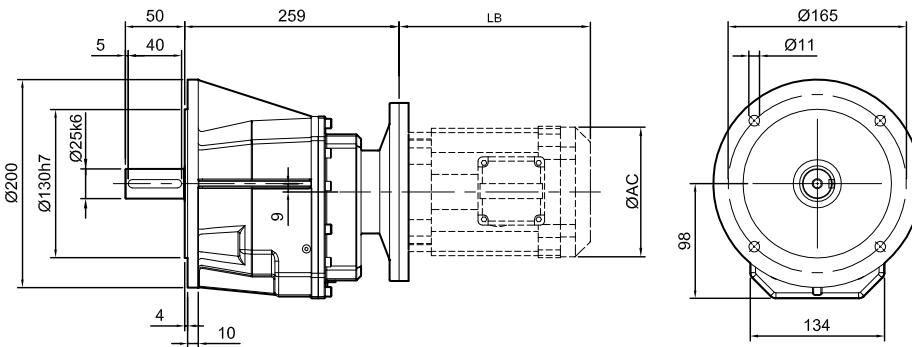

	IEC	M	M2	M1	N	N1	N2	N3	N4	X	FM		FM - DCB	
											LB	AC	LB	AC
FH25-3	F63	11	4	12.8	140	115	95		9	5	184	120	247	120
FH25-3	F71	14	5	16.3	160	130	110	-	9	5	201	140	258	140
FH25-3	F80	19	6	21.8	200	165	130	-	11	5	227	156	290	156

FH25 - 2 - - - ISS

F

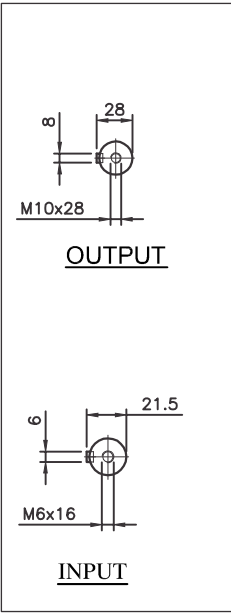
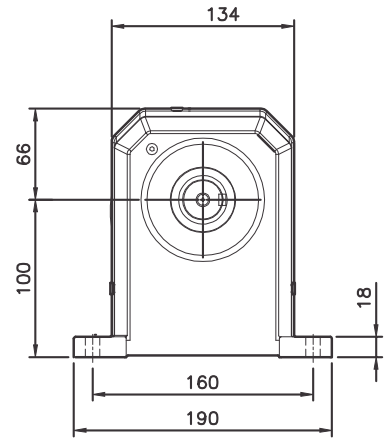
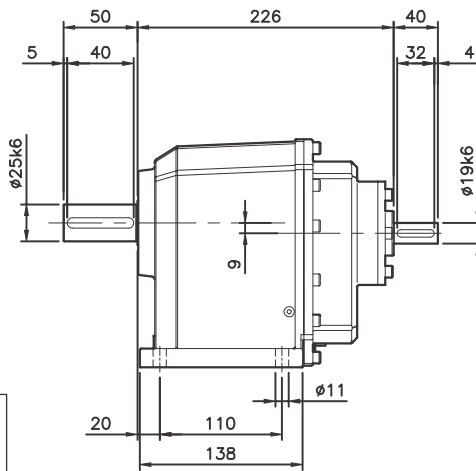

FL

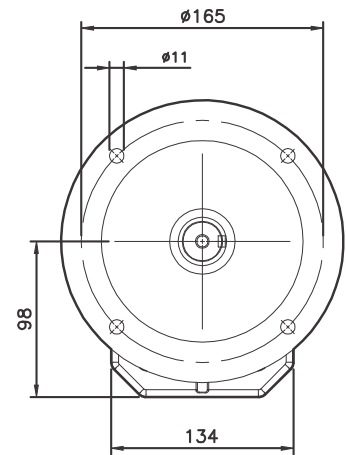
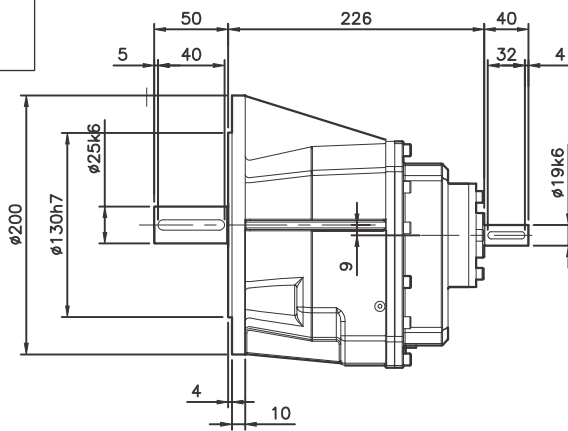

FH25 - 3 - - - ISS

F

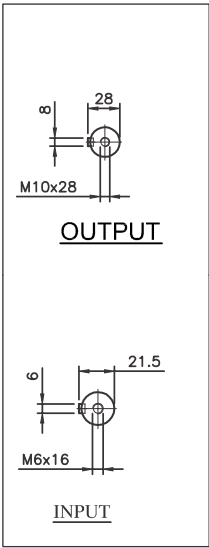
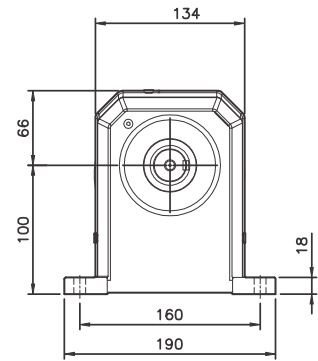
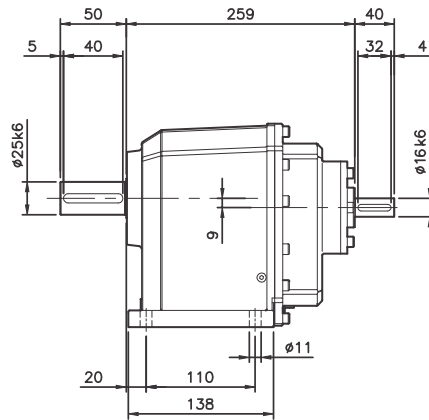

FL

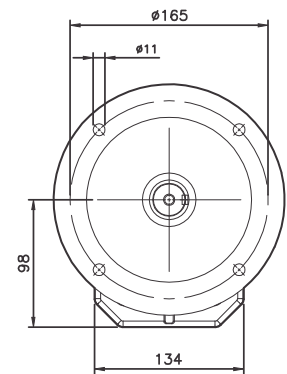
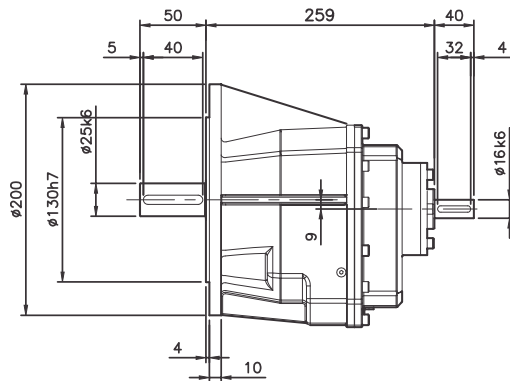

FH30 - 2 - - - IEC

F

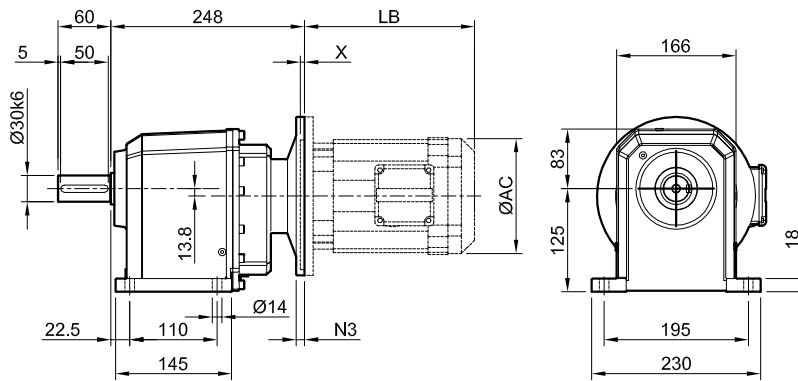

FL

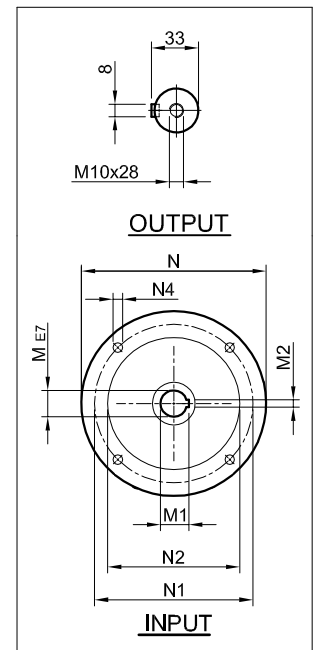
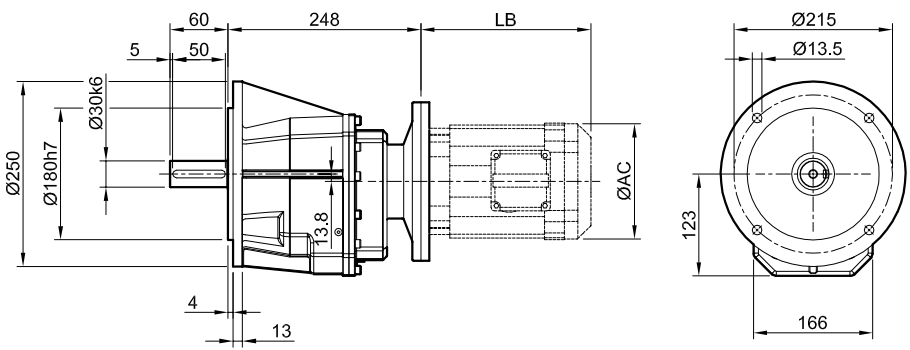

	IEC	M	M2	M1	N	N1	N2	N3	N4	X	FM		FM - DCB	
											LB	AC	LB	AC
FH30-2	F71	14	5	16.3	160	130	110		9	5	201	140	258	140
FH30-2	F80	19	6	21.8	200	165	130	-	11	5	227	156	290	156
FH30-2	F90	24	8	27.3	200	165	130	-	11	5	272	172	322	172
FH30-2	F100	28	8	31.3	250	215	180	-	13.5	8	312	198	387	198
FH30-2	F112	28	8	31.3	250	215	180		13.5	8	320	217	395	217

FH30 - 3 - - - IEC

F

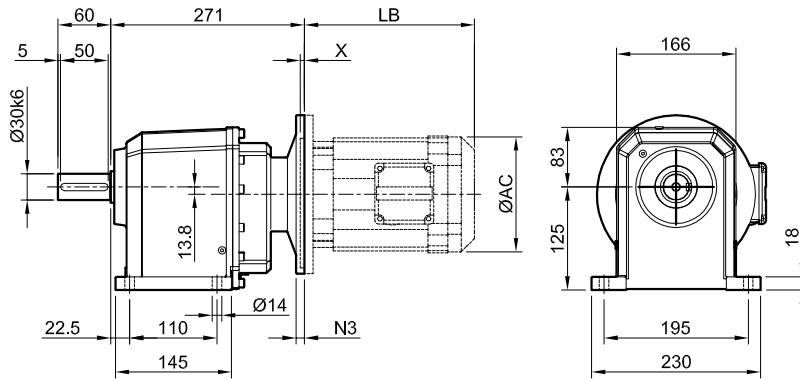

FL

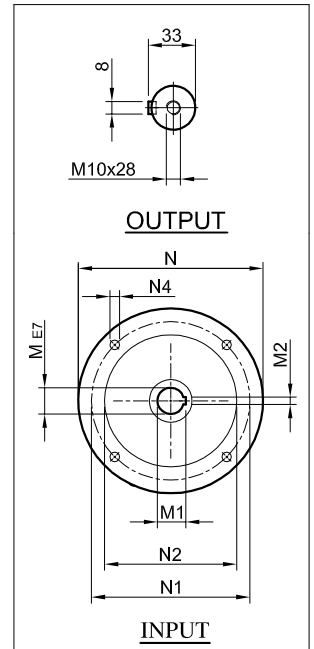
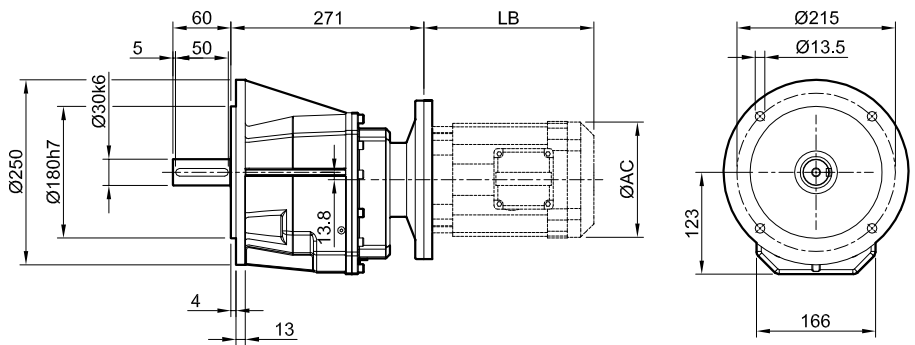

	IEC	M	M2	M1	N	N1	N2	N3	N4	X	FM		FM - DCB	
											LB	AC	LB	AC
FH30-3	F71	14	5	16.3	160	130	110		9	5	201	140	258	140
FH30-3	F80	19	6	21.8	200	165	130	-	11	5	227	156	290	156
FH30-3	F90	24	8	27.3	200	165	130	-	11	5	272	172	322	172

FH30 - 2 - - - ISS

F

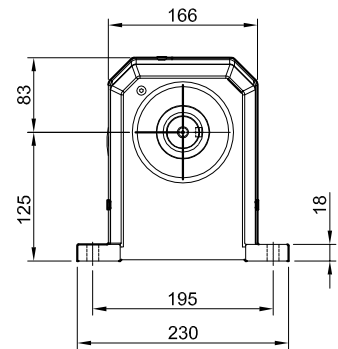
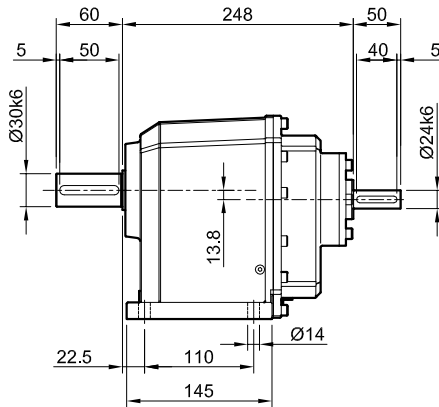
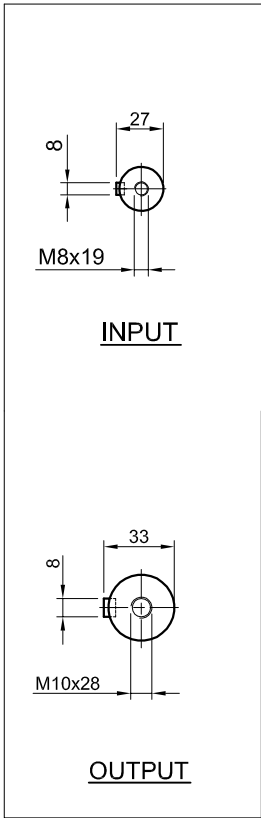

FL

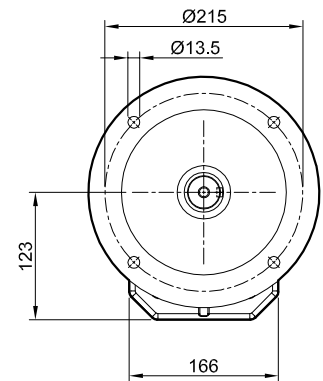
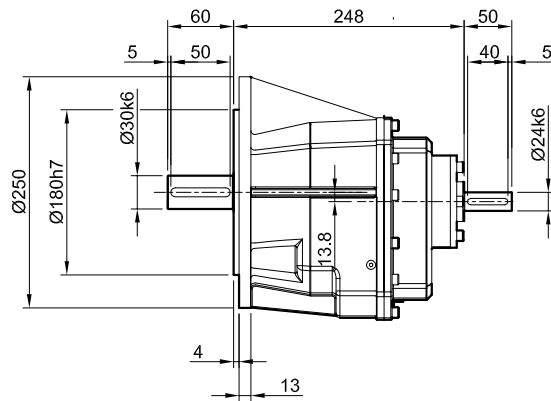

FH30 - 3 - - - ISS

F

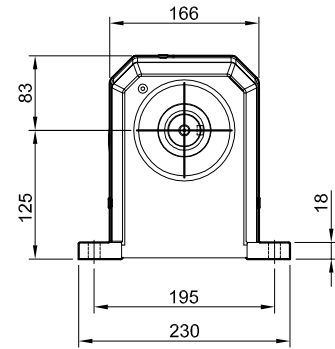
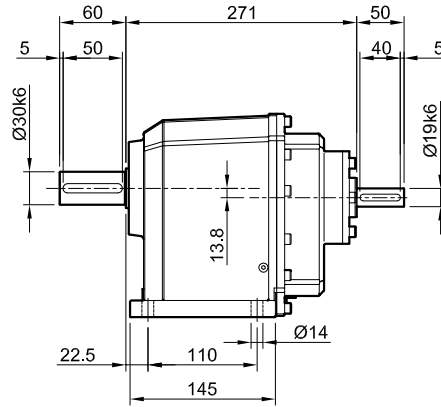

INPUT

OUTPUT

FL

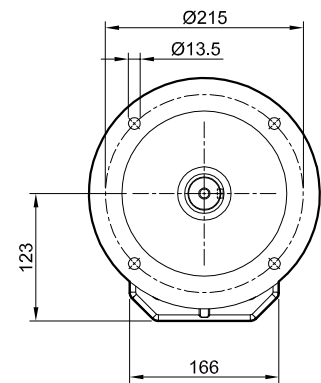
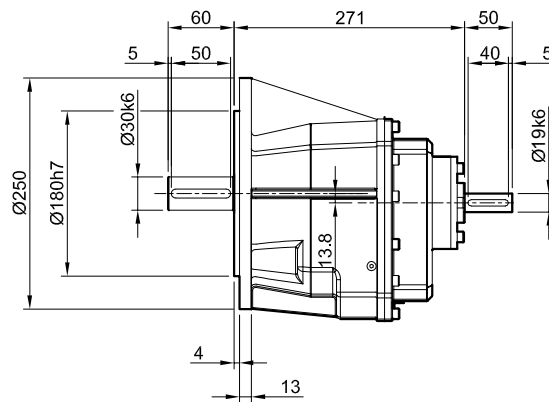

FH35 - 2 - - - IEC

F

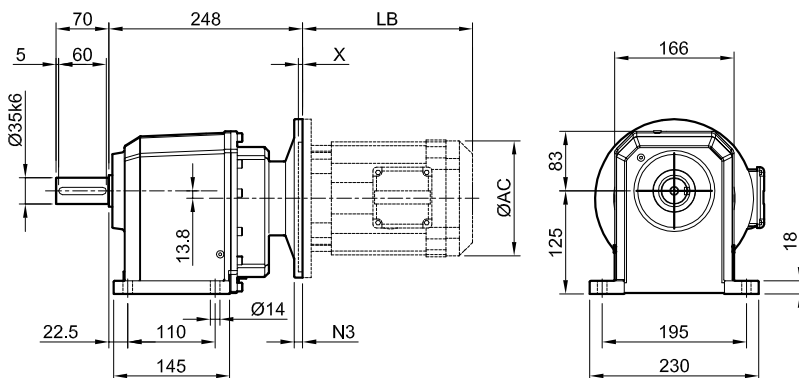

FL

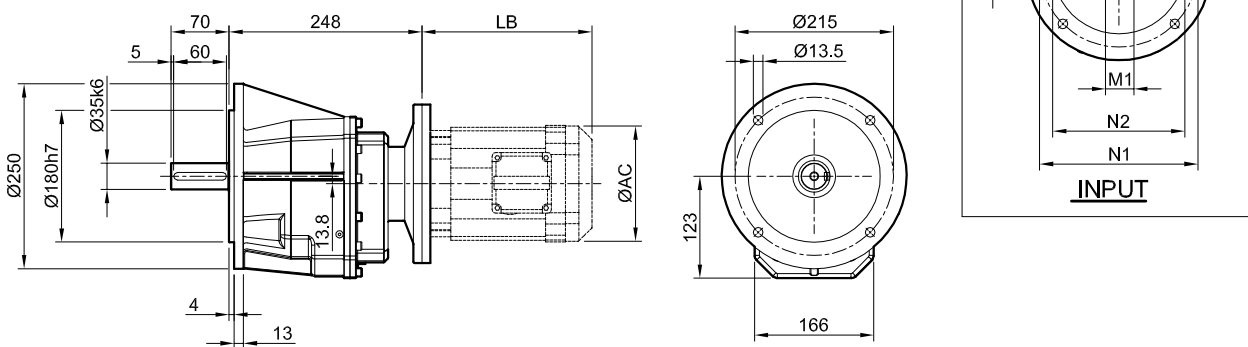

	IEC	M	M2	M1	N	N1	N2	N3	N4	X	FM		FM - DCB	
											LB	AC	LB	AC
FH35-2	F80	19	6	21.8	200	165	130		11	5	227	156	290	156
FH35-2	F90	24	8	27.3	200	165	130	-	11	5	272	172	322	172
FH35-2	F100	28	8	31.3	250	215	180	-	13.5	8	312	198	387	198
FH35-2	F112	28	8	31.3	250	215	180	-	13.5	8	320	217	395	217

FH35 - 3 - - - IEC

F

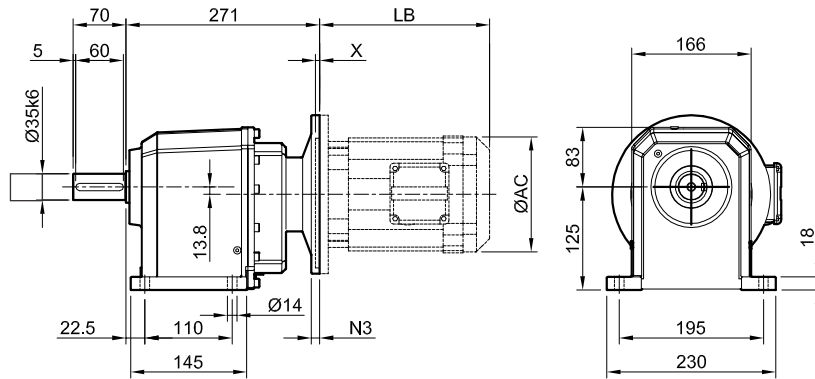

FL

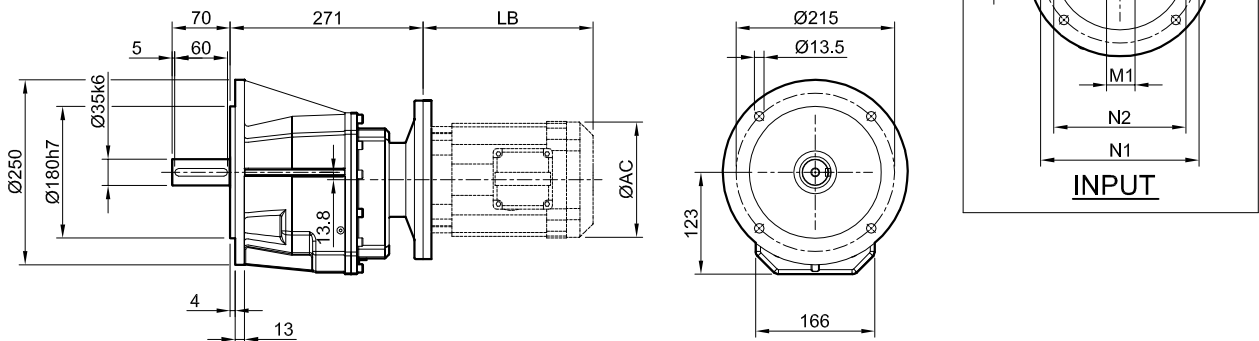

	IEC	M	M2	M1	N	N1	N2	N3	N4	X	FM		FM-DCB	
											LB	AC	LB	AC
FH35-3	F71	14	5	16.3	160	130	110		9	5	201	140	258	140
FH35-3	F80	19	6	21.8	200	165	130	-	11	5	227	156	290	156
FH35-3	F90	24	8	27.3	200	165	130	-	11	5	272	172	322	172

FH35 - 3 - - - ISS

F

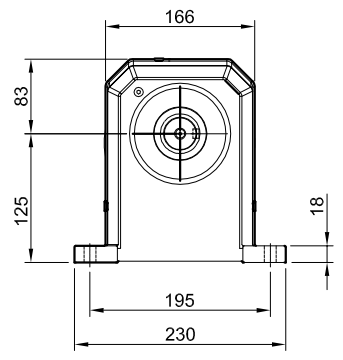
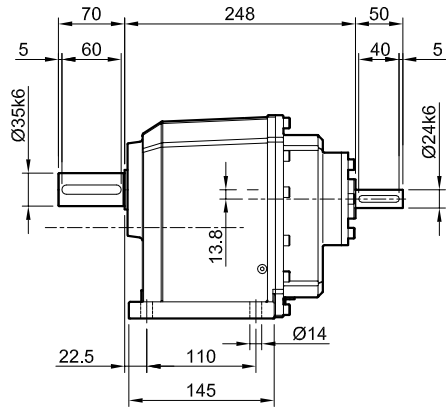

INPUT

OUTPUT

FL

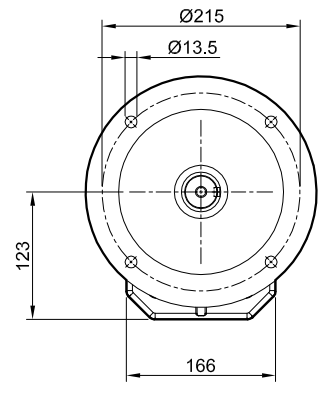
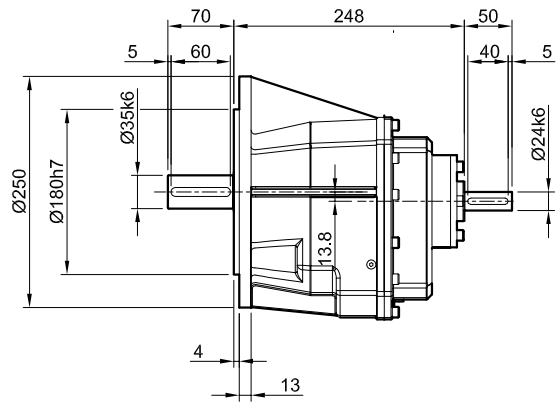

FH35 - 3 - - - ISS

F

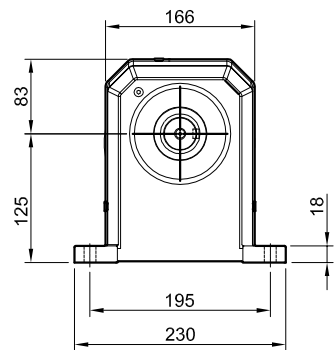
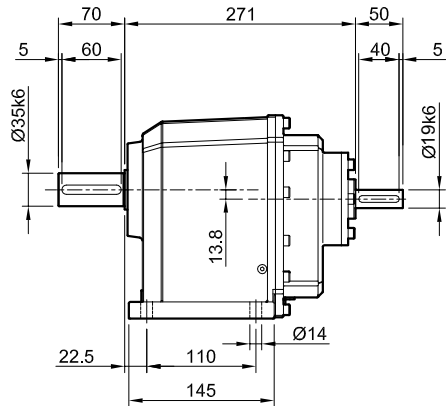

INPUT

OUTPUT

FL

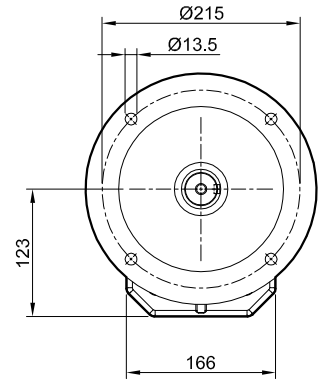
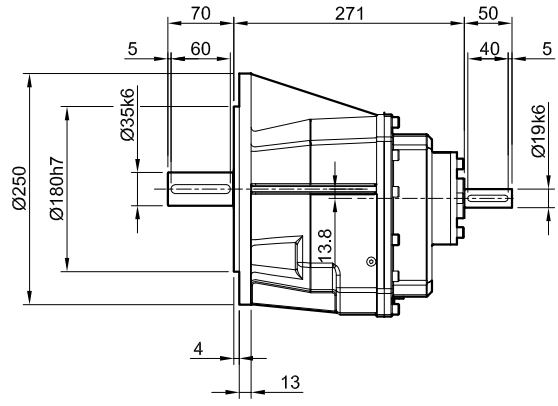

FH50 - 2 - - - IEC

F

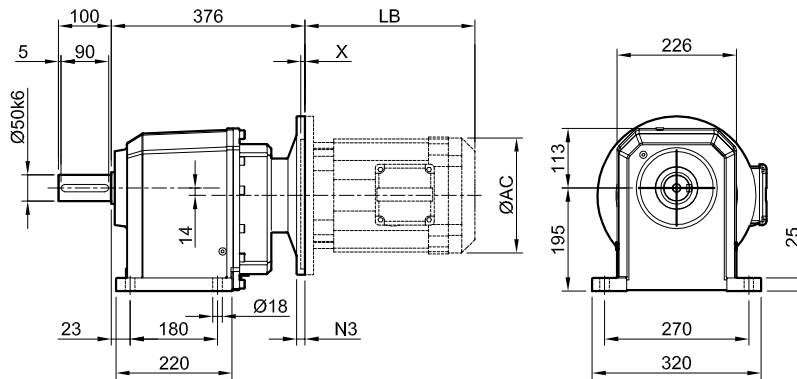

FL

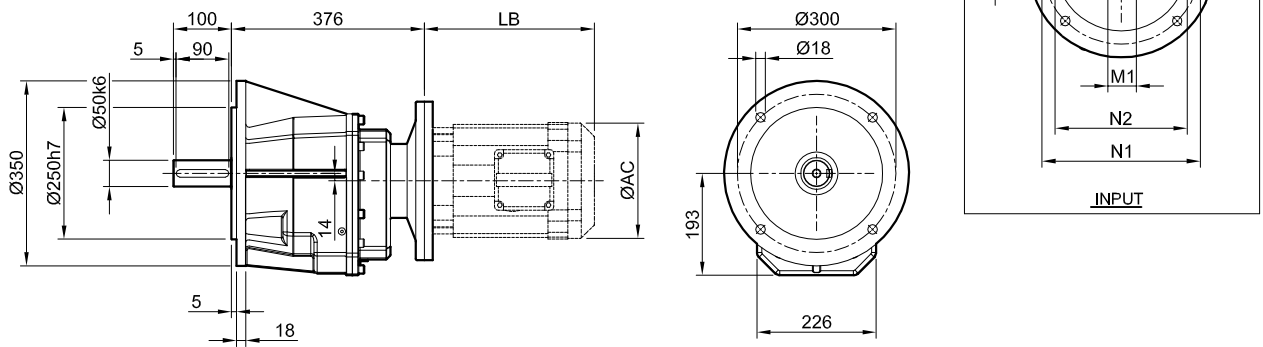

	IEC	M	M2	M1	N	N1	N2	N3	N4	X	FM		FM - DCB	
											LB	AC	LB	AC
FH50-2	F100	28	8	31.3	250	215	180	-	13.5	8	312	198	387	198
FH50-2	F112	28	8	31.3	250	215	180	-	13.5	8	320	217	395	217
FH50-2	F132	38	10	41.3	300	265	230	-	14	8	-	-	-	-
FH50-2	F160	42	12	45.3	350	300	250	-	18	8	-	-	-	-

FH50 - 3 - - - IEC

F

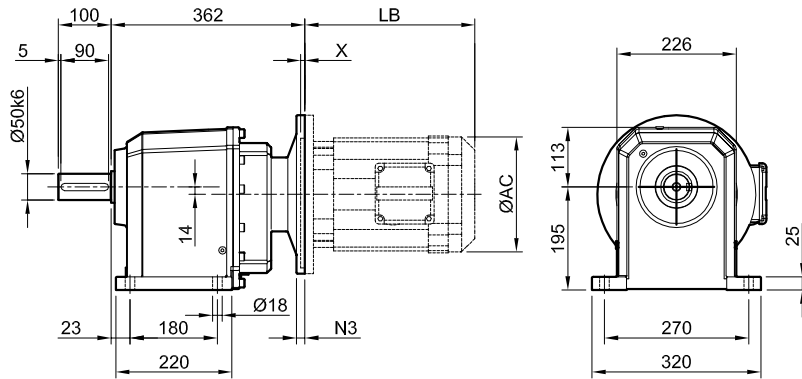

FL

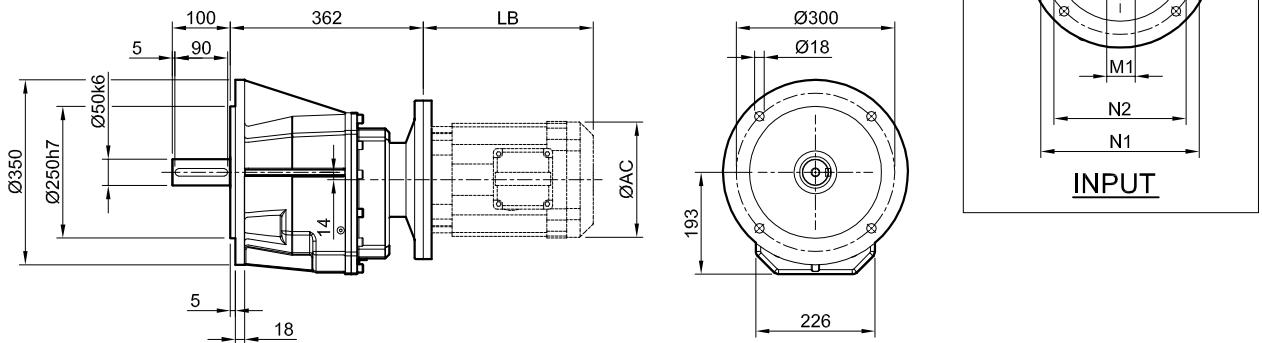

	IEC	M	M2	M1	N	N1	N2	N3	N4	X	FM		FM-DCB	
											LB	AC	LB	AC
FH50-3	F90	24	8	27.3	200	165	130	-	11	5	272	172	322	172
FH50-3	F100	28	8	31.3	250	215	180	-	13.5	8	312	198	387	198
FH50-3	F112	28	8	31.3	250	215	180	-	13.5	8	320	217	395	217

FH50 - 2 - - - ISS

F

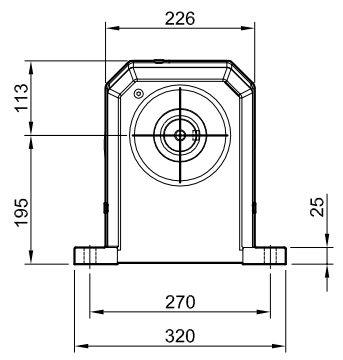
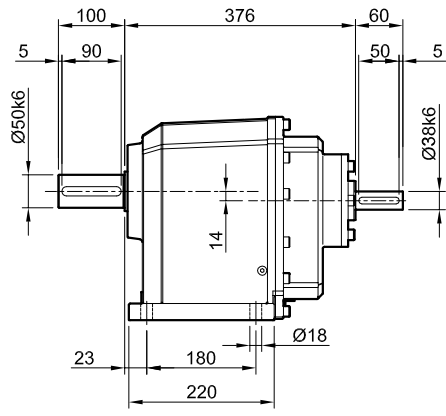

INPUT

OUTPUT

FL

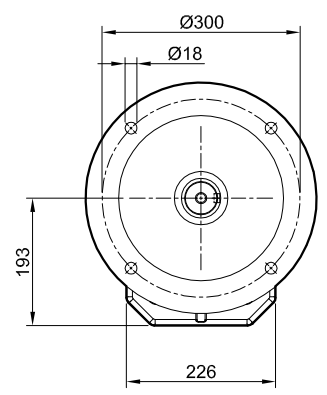
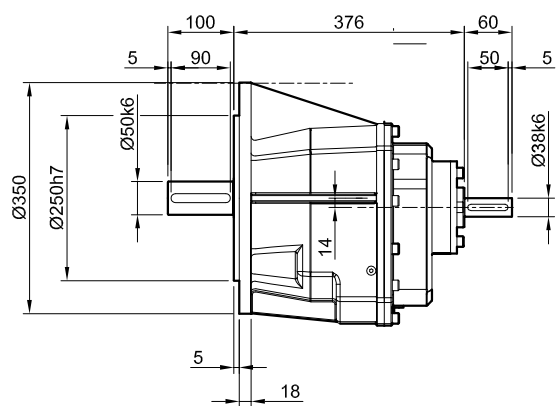

FH50 - 3 - - - ISS

F

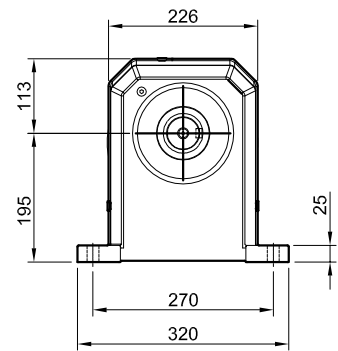
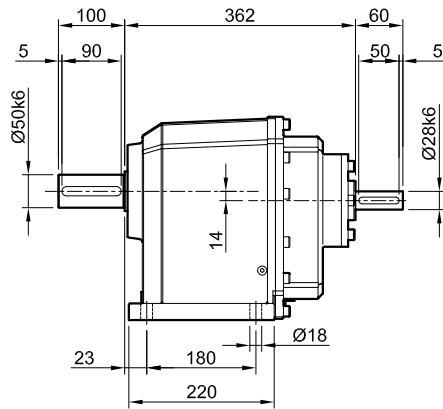

INPUT

OUTPUT

FL

