



Gripper

special

SOMMER
automatic

Collet Gripper



Order no.	Total stroke in ø [mm]	Gripping moment (Nm) in opening	Page
Product information LG4-20 up to LG30-50			8
LG4-20	1	0,5	12
LG4-20V	1	0,5	12
LG20-30	1	2,0	14
LG20-30V	1	2,0	14
LG30-50	1	3,0	14

Internal-Hole Gripper



Order no.	Bore diameter min./max. [mm]	Gripping force [N] max. in opening	Page
Product information LG-Serie			20
LG15-18	15,0 / 17,5	100	24
LG18-22	17,5 / 21,5	100	24
LG22-26	21,5 / 25,5	150	24
LG26-30	25,5 / 29,5	150	24
LG30-35	29,5 / 4,5	200	24
LG35-39	34,5 / 39	300	24
LG40-45	39,5 / 46	400	24
LG46-51	45,5 / 51,5	500	24
LG51-56	50,5 / 57,5	750	24
LG56-62	55,5 / 63	900	24
LG63-70	62,5 / 70,5	1.100	24
LG71-80	70,5 / 81	1.500	24
LG76-84	75,5 / 84	1.700	24
LG81-90	80,5 / 91,5	2.000	24
LG91-100	90,5 / 100,5	2.500	24
LG100-110	99,5 / 110,5	2.800	24
LG110-120	109,5 / 120,5	3.500	24
LG120-135	119,5 / 135,5	3.500	24

Needle Gripper



Order no.	Adjustable stroke up to [mm]	Gripping force in extraction [N]	Page
Product information ST-Serie			28
ST36	0 / 1,5	100	32
ST40	0 / 2	160	32

Needle Gripper

Order no.	Adjustable stroke up to [mm]	Gripping force in extraction [N]	Page
Product information SCH-Serie			36
SCH20	0/6	35	40
SCH23	0/6	35	40



O-Ring Gripper

Order no.	Opening stroke adjustable [mm]	Gripping force in opening [N]	Page
Product information GS-Serie			44
GS65	3 – 6	300	48
GS1015	1,6 – 10	1.450	50



Cutting Tongs

Order no.	Stroke per jaw [°]	Gripping force in closing [N]	Page
Product information ZK-Serie			54
ZK22	7,5	3.600	58
ZK33	9,0	6.800	60



Tube Gripper

Order no.	Grip diameter min./max. [mm]	Gripping force in closing [N]	Page
Product information RG-Serie			64
RG0-30	0 / 28	350	68
RG10-60	10 / 58	1.000	68



Parallel Gripper with tool intake

Order no.	Tool intake	Gripping force in closing adjustable	Page
Product information GFP			70
GFP2012NC-14	HSK-A63	460N - 1140N	74
GFP2012NC-25	VDI 40	460N - 1140N	74
GFP2012NC-34	Capto C4	460N - 1140N	74





Collet Gripper

pneumatic



LG 4-20
LG 4-20V
LG20-30
LG20-30V
LG30-50

SOMMER
automatic

Collet Gripper

➤ Features

- Low steering effort due to single effect rubber membrane
- Including universal collet chuck for individual processing
- Hole diameter of 4 to 50 mm available

Functional diagram

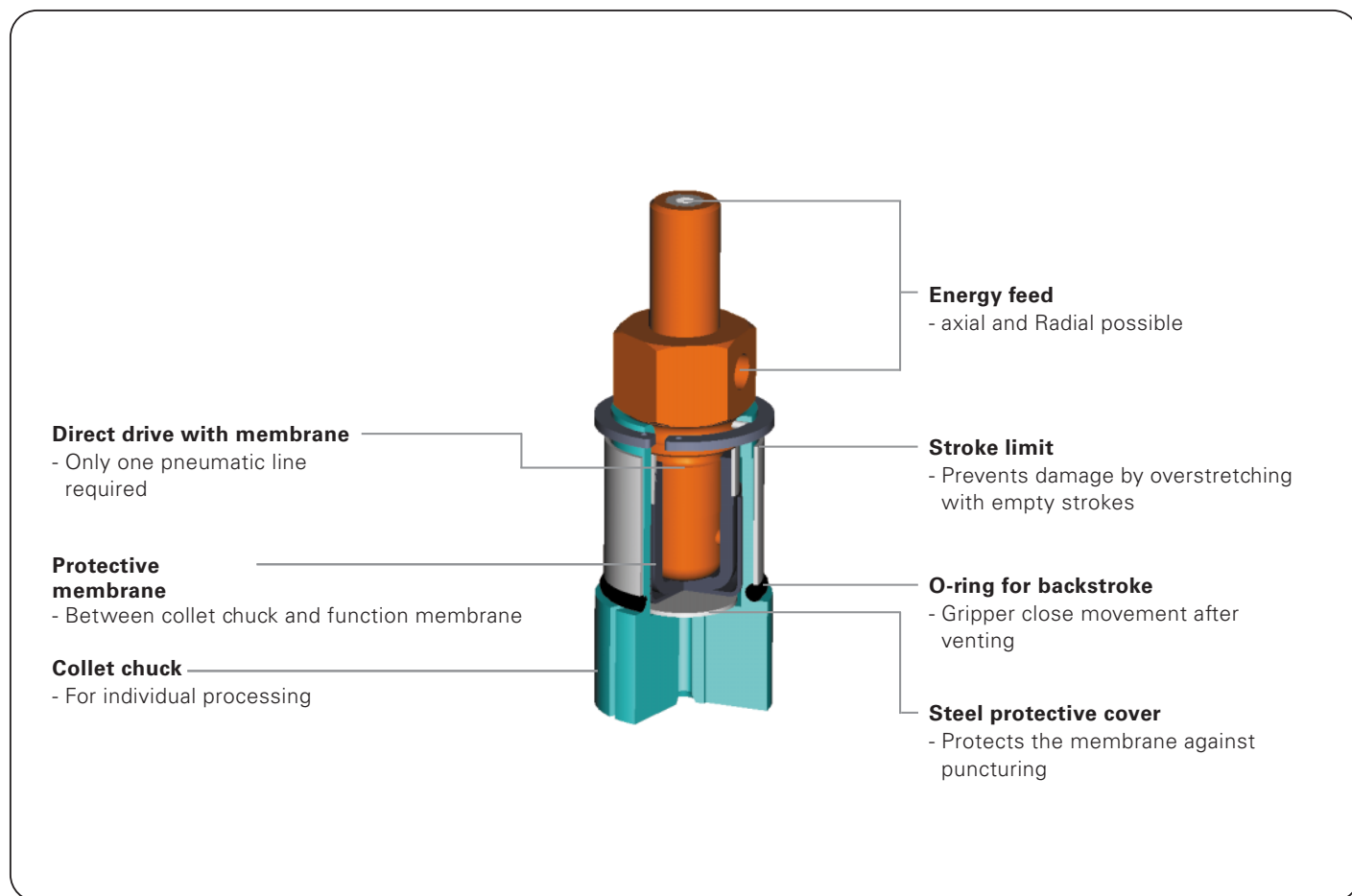

Terms

- Gripping force:** arithmetic sum of the individual forces occurring at the jaws
- Closing-/opening time:** time required by the gripping jaws to travel the entire stroke distance
- Repeatability:** dispersion of stop positions at 50/100 consecutive cycles/strokes
- Cycle:** distance covered by the membrane in one open and close movement
- Maintenance:** maintenance free
 (please see the owner’s manual for conditions,
 download from www.sommer-automatic.com)

Model

V: Extended collet chuck

Order no.	Total stroke in Ø	Internal gripping moment	External gripping	Max. possible length of the collet chuck for machining
LG4-20	1 mm	0,5 Nm	unsuitable	9 mm
LG4-20V	1 mm	0,5 Nm	unsuitable	25 mm
LG20-30	1 mm	2 Nm	unsuitable	10 mm
LG20-30V	1 mm	2 Nm	unsuitable	35 mm
LG30-50	1 mm	3 Nm	unsuitable	11 mm

Collet Gripper

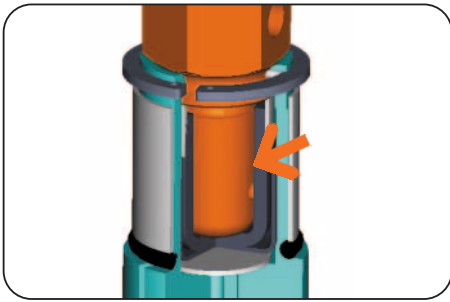

Drive

Single effect rubber membrane

- Steering effort low
- Only one pneumatic line required

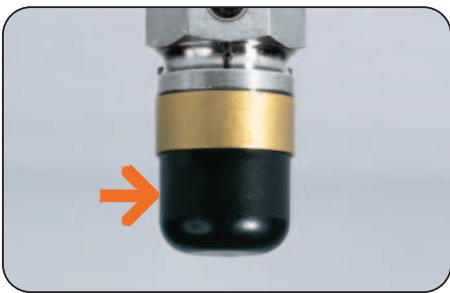

Force transfer

Via rubber membrane

- Direct
- Loss free

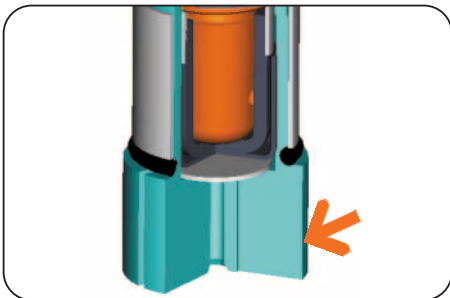

Collet chuck

In 16 MnCr5

Included in the delivery

- Can be machined individually
- Possible hole diameter from 4 to 50 mm
- Length from 9 to 35 mm

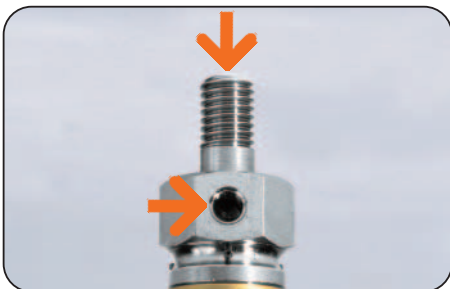

Energy feed

Axial and radial

- Flexible integration into the machine
- Individual installation of pneumatic line

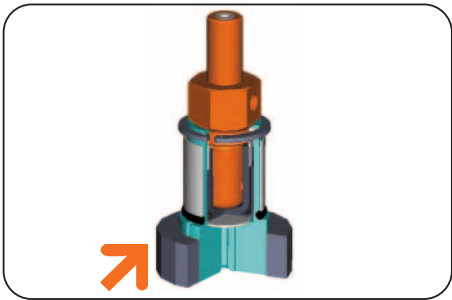

Internal gripping

For gripping in a hole

For workpieces with complex outside contours

- Quick and cost-effective to use
- Individual and application specific
- Simple manufacturing of gripping jaws by machining of the required diameter

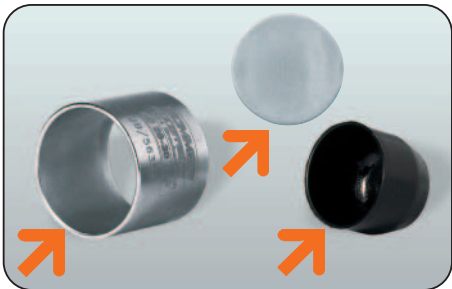

Protective equipment

Steel sleeve as stroke limitation

Protective membrane to increase durability of the function membrane

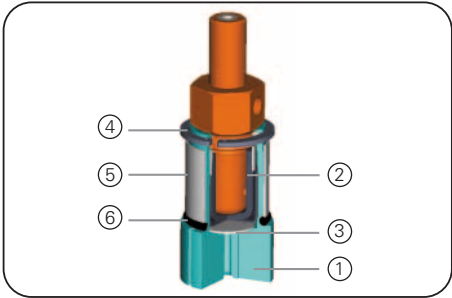

Assembly

Process collet chuck ① individually. Then separate the three, preslotted jaws, clean deburr and polish. Lay out protective membrane ② and steel sheet ③ and mount the three resulting segments on the housing. Assemble the safety ring ④ and stroke limitation ⑤. Wind up to the O-ring ⑥ for the jaw return.

Collet Gripper



Ø 20 mm

Included in the delivery

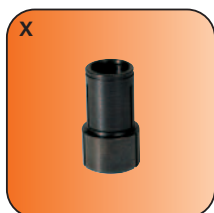

X
Collet chuck
Order no. **BDST04200**
for LG4-20



X'
Collet chuck
Order no. **BDST04201**
for LG4-20V

Accessory list

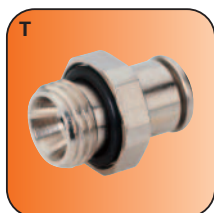

T
Pneumatic fittings
Order no. **GVM5**



X'
Pneumatic fittings
Order no. **WVM5**

Accessories LG4-20

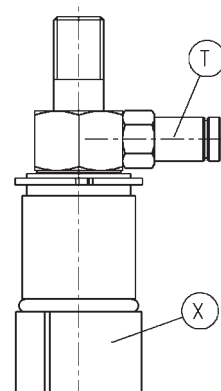
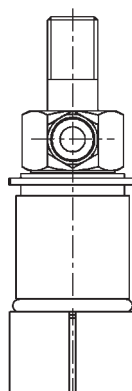

Accessories LG4-20V

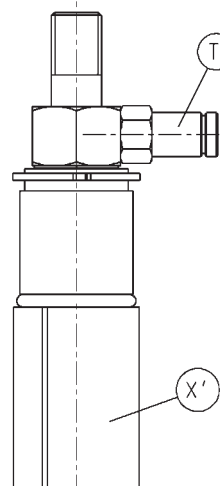
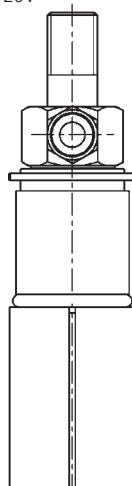

Subject to change without prior notice



Order no.:	LG4-20	LG4-20V
Total stroke in Ø [mm]:	1	1
Gripping force diameter min. [mm]:	4	4
Gripping torque in opening [Nm]:	0,5	0,5
Closing time/opening time [s]:	0,1	0,1
Recommended workpiece weight [g]*:	73	73
Min./max. operating pressure [bar]:	4/6	4/6
Air volume per cycle [cm³]:	1	1
Min./max. operating temperature [°C]**:	5/60	5/60
Weight [g]:	75	115
⑪ Possible length for machining [mm]:	9	25

All data measured at 6 bar

* Value determined with friction coefficient $\mu = 0.1$ and safety factor $\nu = 2$

** High temperature resistant model (up to 150 °C) add „T“ to part number

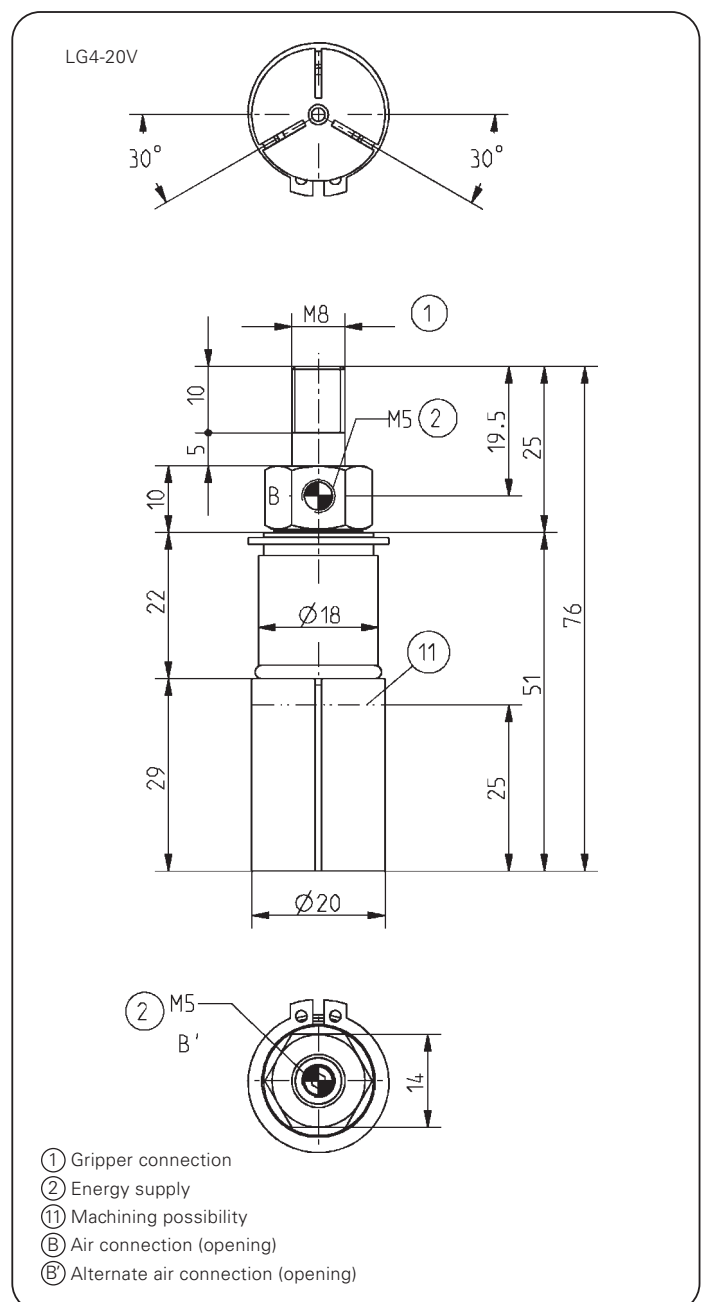
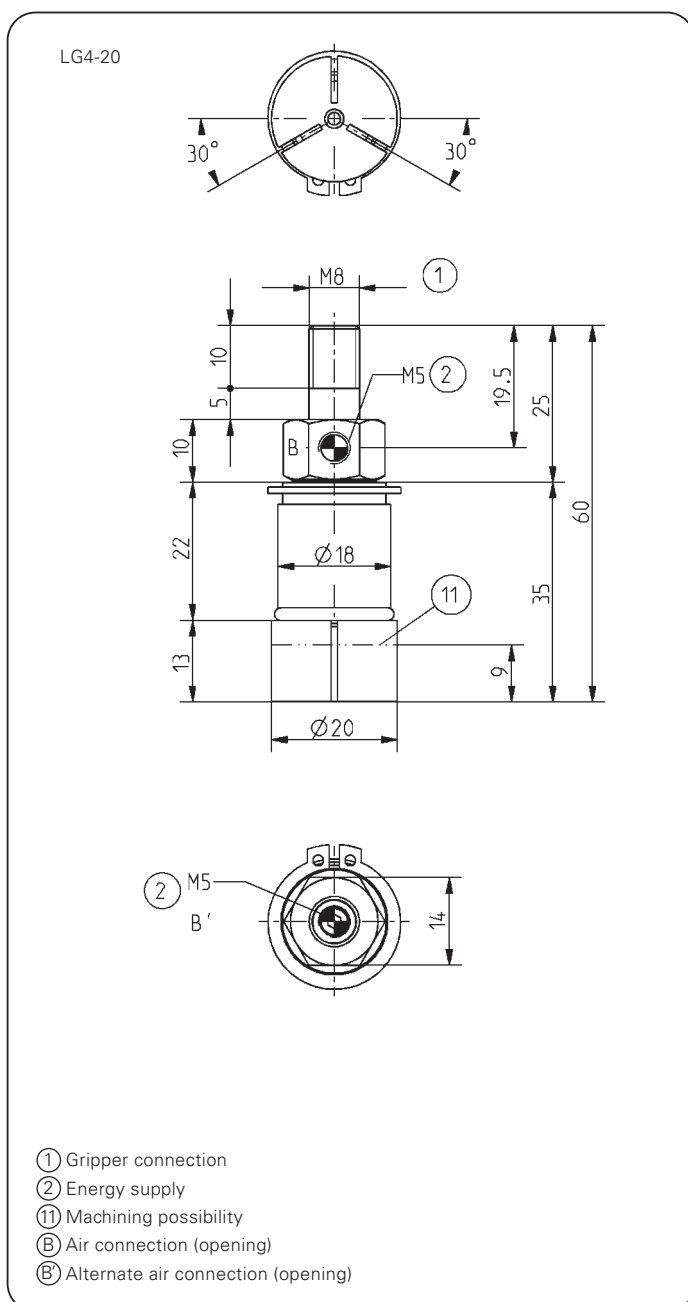

Subject to change without prior notice

Collet Gripper



Ø 30 mm

Included in the delivery

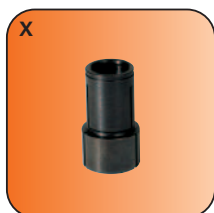

X
Collet chuck
Order no. **BDST20300**
for LG20-30



X'
Collet chuck
Order no. **BDST20301**
for LG20-30V

Accessory list

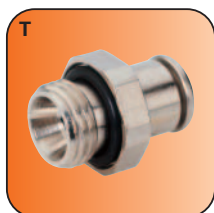

T
Pneumatic fittings
Order no. **GVM5**



X'
Pneumatic fittings
Order no. **WVM5**

Accessories LG20-30

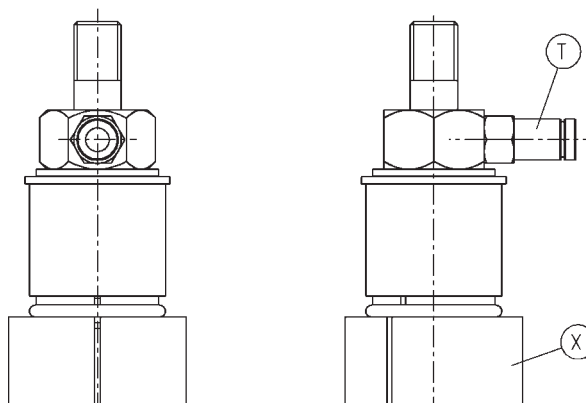

Accessories LG20-30V

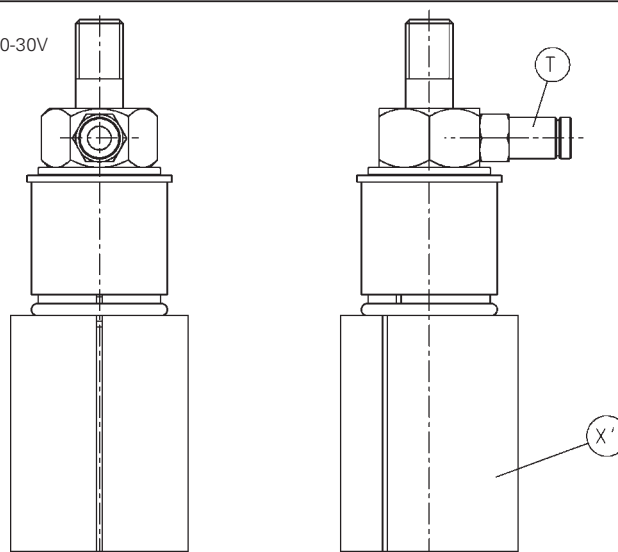

Subject to change without prior notice



Order no.:	LG20-30	LG20-30V
Total stroke in Ø [mm]:	1	1
Gripping force diameter min. [mm]:	5	5
Gripping torque in opening [Nm]:	2	2
Closing time/opening time [s]:	0,1	0,1
Recommended workpiece weight [g]*:	255	255
Min./max. operating pressure [bar]:	4/6	4/6
Air volume per cycle [cm ³]:	3	3
Min./max. operating temperature [°C]**:	5/60	5/60
Weight [g]:	160	290
⑪ Possible length for machining [mm]:	10	35

All data measured at 6 bar

* Value determined with friction coefficient $\mu = 0.1$ and safety factor $\nu = 2$

** High temperature resistant model (up to 150 °C) add „T” to part number

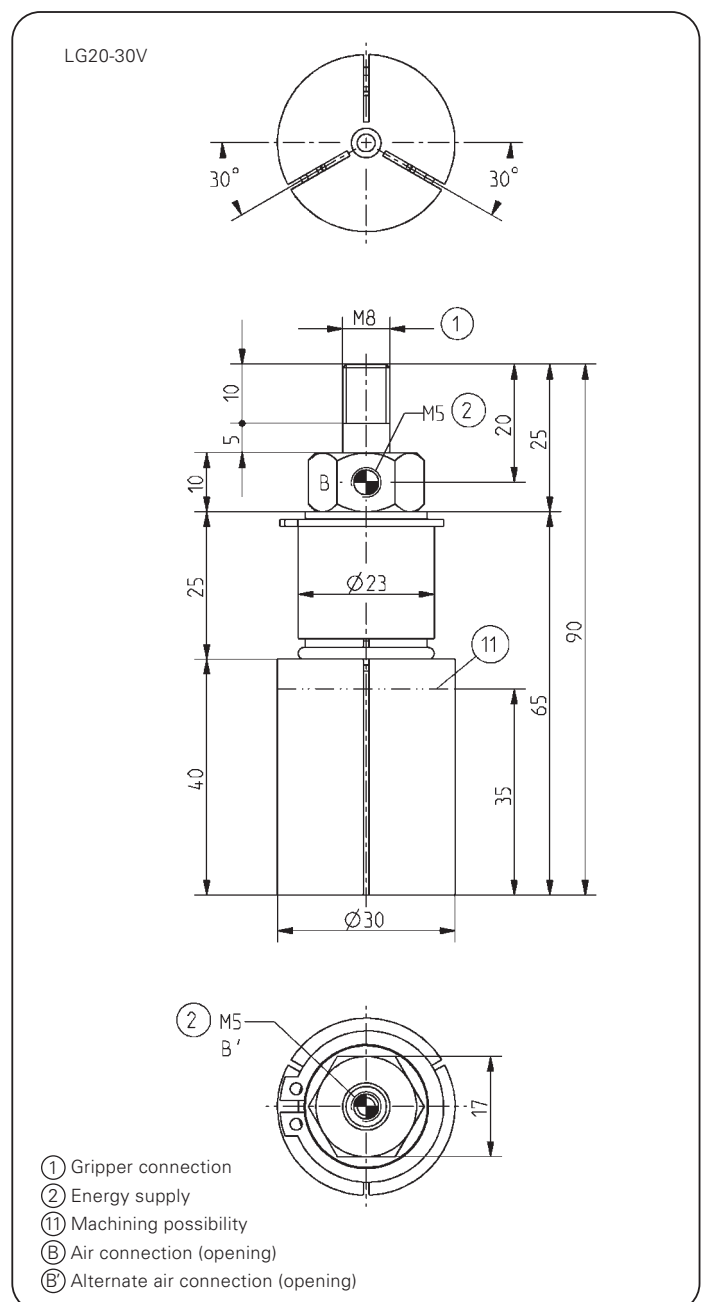
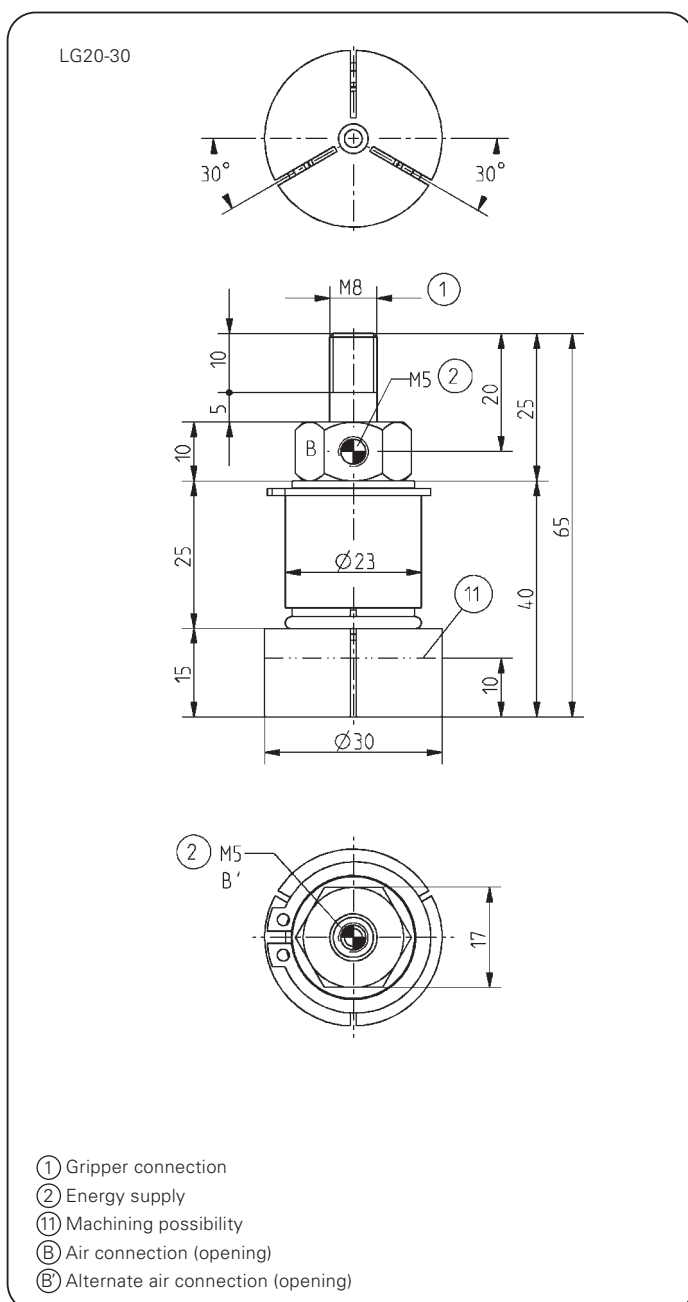

Subject to change without prior notice

Collet Gripper



Included in the delivery



Collet chuck
Order no. BDST30500

Accessory list



Pneumatic fittings
Order no. GVM5



Pneumatic fittings
Order no. WVM5

Accessories

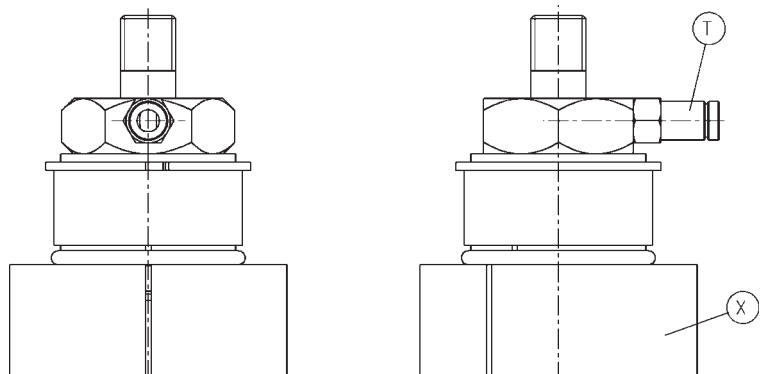

Subject to change without prior notice

Order no.:	LG30-50
Total stroke in Ø [mm]:	1
Gripping force diameter min. [mm]:	6
Gripping torque in opening [Nm]:	3
Closing time/opening time [s]:	0,1
Recommended workpiece weight [g]*:	380
Min./max. operating pressure [bar]:	4/6
Air volume per cycle [cm ³]:	5
Min./max. operating temperature [°C]**:	5/60
Weight [g]:	460
⑪ Possible length for machining [mm]:	11

All data measured at 6 bar

* Value determined with friction coefficient $\mu = 0.1$ and safety factor $\nu = 2$

** High temperature resistant model (up to 150 °C) add „T“ to part number

LG30-50

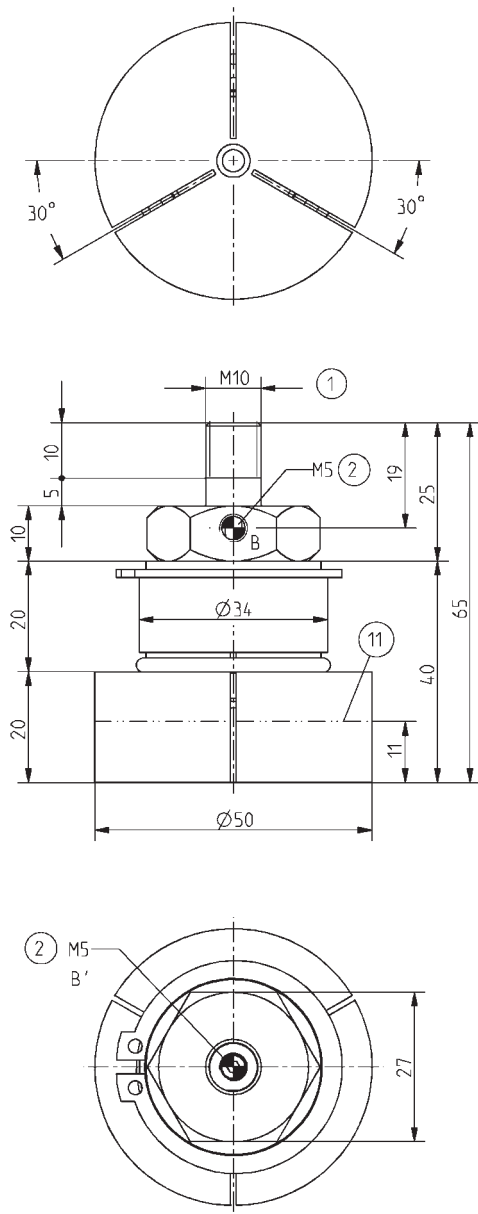

- ① Gripper connection
- ② Energy supply
- ⑪ Machining possibility
- B Air connection (opening)
- B' Alternate air connection (opening)

Subject to change without prior notice



Internal-Hole Gripper

pneumatic



LG-Series

SOMMER
automatic

Internal-Hole-Gripper

➤ Features

- Surface-protecting internal gripping using rubber knobs
- Gripping force of 33 to 3500 N directly regulable via working pressure
- Very good friction value due to direct contact between workpiece and rubber membrane

Functional diagram

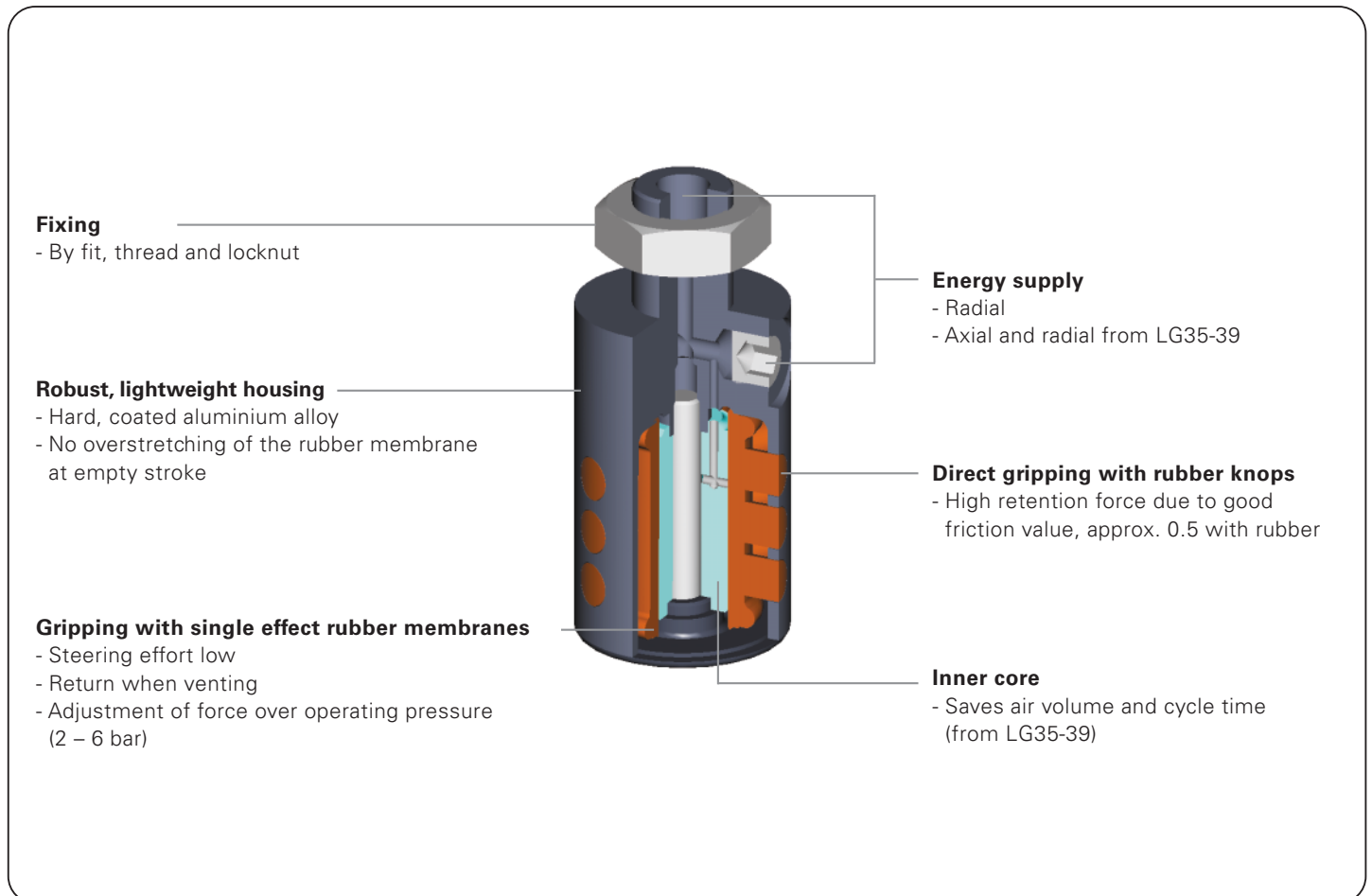

Terms

Gripping force:	arithmetic sum of the individual forces occurring on the rubber knobs
Closing-/opening time:	time required by the rubber knobs to travel the entire stroke distance
Repeatability:	dispersion of stop positions at 50/100 consecutive cycles/strokes
Cycle:	distance covered by the membrane in one open and close movement
Maintenance:	maintenance free (please see the owner's manual for conditions, download from www.sommer-automatic.com)

Model

Order no.	Bore diameter min. / max.	Internal gripping force
LG15-18	15,0 / 17,5 mm	100 N
LG18-22	17,5 / 21,5 mm	100 N
LG22-26	21,5 / 25,5 mm	150 N
LG26-30	25,5 / 29,5 mm	150 N
LG30-35	29,5 / 4,5 mm	200 N
LG35-39	34,5 / 39 mm	300 N
LG40-45	39,5 / 46 mm	400 N
LG46-51	45,5 / 51,5 mm	500 N
LG51-56	50,5 / 57,5 mm	750 N
LG56-62	55,5 / 63 mm	900 N
LG63-70	62,5 / 70,5 mm	1100 N
LG71-80	70,5 / 81 mm	1500 N
LG76-84	75,5 / 84 mm	1700 N
LG81-90	80,5 / 91,5 mm	2000 N
LG91-100	90,5 / 100,5 mm	2500 N
LG100-110	99,5 / 110,5 mm	2800 N
LG110-120	109,5 / 120,5 mm	3500 N
LG120-135	119,5 / 135,5 mm	3500 N

Tip for use:

- **The operating pressure should only be as high as necessary, to increase durability**
- **All rubber knobs have to be in mesh**
- **Only usable in clean environmental**
- **In the wet area, in adverse and in oily environments there is a marked decrease in friction value**

Internal-Hole-Gripper

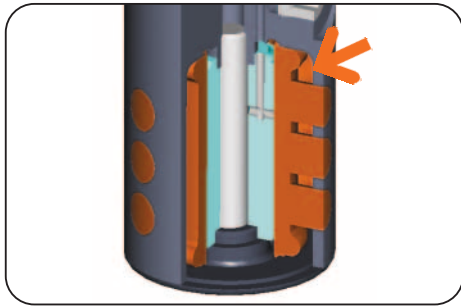

Drive

Single effect rubber membranes

- Steering effort low
- Only one pneumatic line required



Force transfer

Direct internal gripping via rubber knobs

- Low loss
- Optimum friction value
- No gripping jaw production required
- No metallic contact

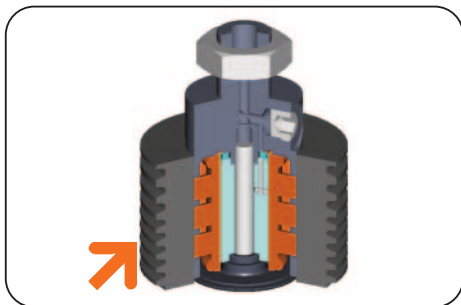

Internal gripping

For gripping in a hole

For workpieces with complex outside contours or sensitive components

- Workpiece specific jaws no longer required
- For internal diameters from 15 to 135 mm



Energy feed

Axial and radial (from LG35-39)

- Flexible integration into the machine
- Individual installation of pneumatic line



Gripping membrane with inner core

- Saves air volume
- Rapid cycle times

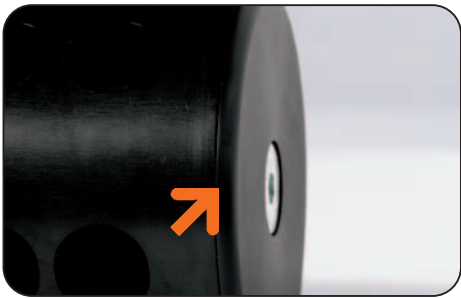

Positioning aid

- Radii as insert aid
- Compensating

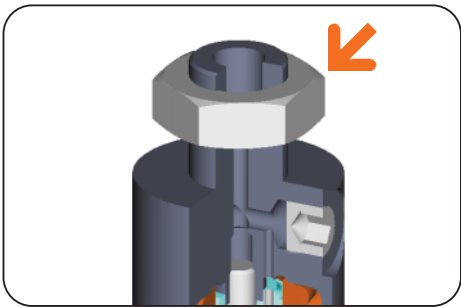

Fixing

- By fit, thread and locknut
- Easy assembly

Internal-Hole-Gripper





Ø K
 up 14,5 to 119 mm

LG15-18 – LG30-35

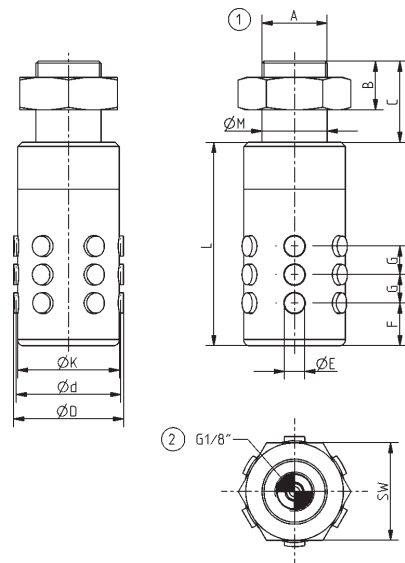

- ① Gripper connection
- ② Energy supply

Accessory list



Pneumatic fittings
Order no. GV1/8x6



Pneumatic fittings
Order no. GV1/4x6

Accessories LG15-18 – LG30-35

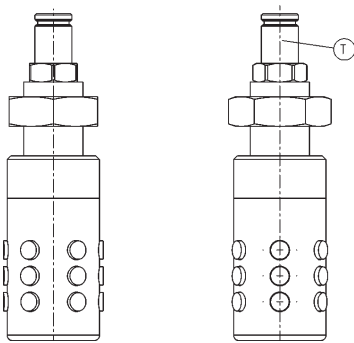

- ① Gripper connection
- ② Energy supply

LG35-39 – LG91-100

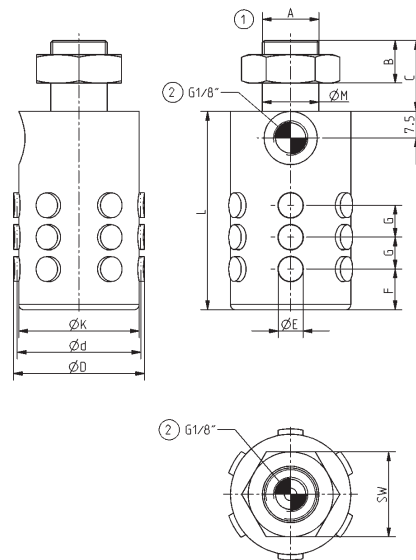

- ① Gripper connection
- ② Energy supply

Accessories LG35-39 – LG120-135

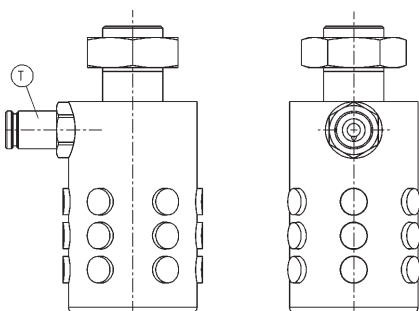

- ① Gripper connection
- ② Energy supply

LG100-110 – LG120-135

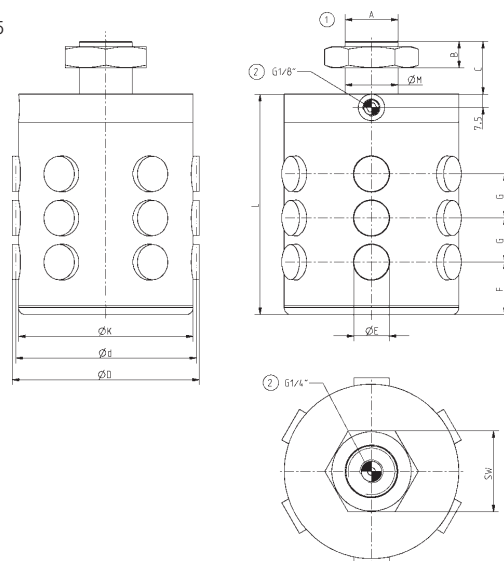

- ① Gripper connection
- ② Energy supply

Subject to change without prior notice



Order no.:	LG15-18	LG18-22	LG22-26	LG26-30	LG30-35	LG35-39
Total stroke in Ø [mm]:	2,5	4	4	4	5	4,5
Clamping diameter d min. [mm]:	15	17,5	21,5	25,5	29,5	34,5
Clamping diameter D max. [mm]:	17,5	21,5	25,5	29,5	34,5	39
Gripping force in extraction [N]*:	100	100	150	150	200	300
Recommended workpiece weight opening [kg]*:	0,5	0,5	0,8	0,8	1	1,5
Retract time and extend time [s]:	0,2	0,2	0,2	0,2	0,2	0,2
Repeatability +/- [mm]:	0,2	0,2	0,2	0,2	0,2	0,2
Min./max. operating pressure [bar]:	2/6	2/6	2/6	2/6	2/6	2/6
Air volume per cycle [cm ³]:	1	1	1	2	3	5
Min./max. operating temperature[°C]:	5/80	5/80	5/80	5/80	5/80	5/80
Dimension A [mm]:	M14x1,5	M14x1,5	M14x1,5	M16x1	M16x1	M16x1
Dimension B [mm]:	10	10	12	12	12	12
Dimension C [mm]:	18	18	20	20	20	20
Dimension Ø E [mm]:	5	5	5	5	6	7
Dimension F [mm]:	10,5	10,5	11,5	10,5	11,5	11,5
Dimension G [mm]:	7	7	7	7	8	9
Dimension Ø K [mm]:	14,5	17	21	25	29	34
Dimension L [mm]:	42	42	50	50	52	56
Dimension Ø M [mm]:	14 _{h7}	14 _{h7}	14 _{h7}	16 _{h7}	16 _{h7}	16 _{h7}
SW [mm]:	22	22	22	24	24	24
Weight [g]:	31	35	51	71	90	130

Order no.:	LG40-45	LG46-51	LG51-56	LG56-62	LG63-70	LG71-80
Total stroke in Ø [mm]:	6,5	6	7	7,5	8	10,5
Clamping diameter d min. [mm]:	39,5	45,5	50,5	55,5	62,5	70,5
Clamping diameter D max. [mm]:	46	51,5	57,5	63	70,5	81
Gripping force in extraction [N]*:	400	500	750	900	1100	1500
Recommended workpiece weight opening [kg]*:	2	2,5	3,8	4,6	5,6	7,6
Retract time and extend time [s]:	0,3	0,3	0,3	0,3	0,3	0,3
Repeatability +/- [mm]:	0,2	0,2	0,2	0,2	0,2	0,2
Min./max. operating pressure [bar]:	2/6	2/6	2/6	2/6	2/6	2/6
Air volume per cycle [cm ³]:	8	13	17	25	33	42
Min./max. operating temperature[°C]:	5/80	5/80	5/80	5/80	5/80	5/80
Dimension A [mm]:	M16x1	M16x1	M16x1	M16x1	M20x1,5	M20x1,5
Dimension B [mm]:	12	12	12	12	15	15
Dimension C [mm]:	20	20	20	20	25	25
Dimension Ø E [mm]:	8	9	10	11	12	15
Dimension F [mm]:	14	15,5	17	19	21,5	21,5
Dimension G [mm]:	11	12	13	14,5	15,5	18
Dimension Ø K [mm]:	39	45	50	55	62	70
Dimension L [mm]:	62	68	74	80	86	92
Dimension Ø M [mm]:	16 _{h7}	16 _{h7}	16 _{h7}	16 _{h7}	20 _{h7}	20 _{h7}
SW [mm]:	24	24	24	24	30	30
Weight [g]:	178	260	337	373	530	690

Order no.:	LG76-84	LG81-90	LG91-100	LG100-110	LG110-120	LG120-135
Total stroke in Ø [mm]:	8,5	11	10	11	11	16
Clamping diameter d min. [mm]:	75,5	80,5	90,5	99,5	109,5	119,5
Clamping diameter D max. [mm]:	84	91,5	100,5	110,5	120,5	135,5
Gripping force in extraction [N]*:	1700	2000	2500	2800	3500	3500
Recommended workpiece weight opening [kg]*:	8,7	10,2	12,7	14,3	17,8	17,8
Retract time and extend time [s]:	0,3	0,4	0,4	0,4	0,4	0,4
Repeatability +/- [mm]:	0,2	0,2	0,2	0,2	0,2	0,2
Min./max. operating pressure [bar]:	2/6	2/6	2/6	2/6	2/6	2/6
Air volume per cycle [cm ³]:	53	67	117	150	200	250
Min./max. operating temperature[°C]:	5/80	5/80	5/80	5/80	5/80	5/80
Dimension A [mm]:	M20x1,5	M20x1,5	M20x1,5	M30x1,5	M30x1,5	M30x1,5
Dimension B [mm]:	15	15	15	15	15	15
Dimension C [mm]:	25	25	25	30	30	30
Dimension Ø E [mm]:	15,5	16	18	20	22	22
Dimension F [mm]:	22,7	24,5	26,5	30	31	37
Dimension G [mm]:	19	20	22,5	25	25	28
Dimension Ø K [mm]:	75	80	90	99	109	119
Dimension L [mm]:	96	100	110	120	130	145
Dimension Ø M [mm]:	20 _{h7}	20 _{h7}	20 _{h7}	30 _{h7}	30 _{h7}	30 _{h7}
SW [mm]:	30	30	30	46	46	46
Weight [kg]	0,8	1	1,3	1,9	2,3	2,7

All data measured at 6 bar

* Value determined with friction coefficient $\mu = 0.1$ and safety factor $\nu = 2$



Needle Gripper

pneumatic



ST-Series

SOMMER
automatic

Needle Gripper

Features

- Handling of textiles, soft or porous materials by penetration with needles
- Process safe setting of the workpiece by additional air connection for repelling
- Two designs available, 20 or 40 needles, stroke up to 2 mm

Functional diagram

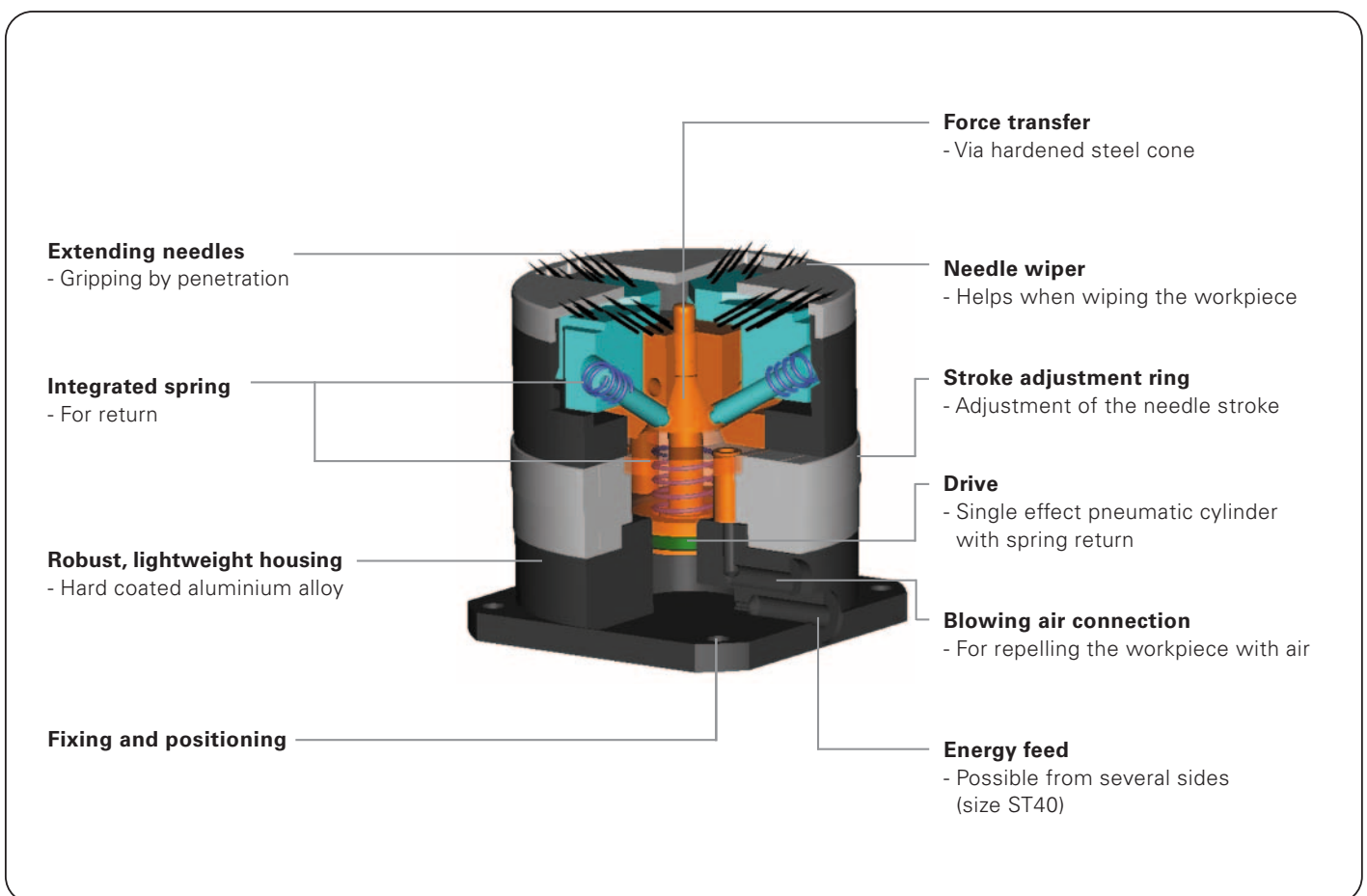



Terms

- Closing-/opening time:** time required by the needles to travel the entire stroke distance
- Repeatability:** dispersion of stop positions at 50/100 consecutive cycles/strokes
- Cycle:** distance covered by the piston in one open and close movement
- Maintenance:** maintenance free bis 5 Mio. cycle
(please see the owner's manual for conditions, download from www.sommer-automatic.com)
- long maintenance intervals keep costs down
 - long durability

Setting

One rotation on the external scale ring corresponds to 0.25 mm stroke change. Measured from the needle point, which extends by under 30°, vertically to the underside of the gripper (cover)

Model

Order no.	Adjustable stroke up to	Number of Needles/Needle holder	Force per needle holder extending	Gripping in
ST36	0/1,5 mm	20/2	100 N	2 directions
ST40	0/2 mm	40/4	160 N	4 directions

Needle Gripper

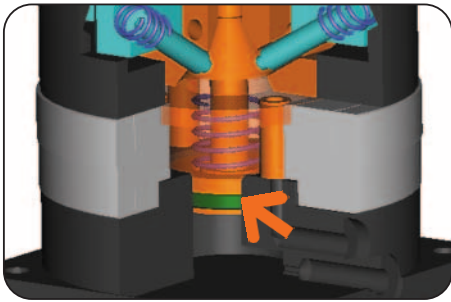

Drive

Single effect pneumatic cylinder

- Low steering effort
- Return via spring



Interlocking gripping

- Penetration with needle under 30°
- Two or four pincushions penetrate in various directions

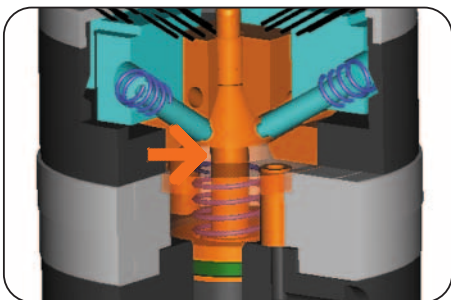

Force transfer

Via hardened steel pin

- Synchronized



Adjustable stroke

Via scale ring from 0 to 2 mm or 1.5 mm

- Infinitely variable
- Flexible
- Protective
- Adjustment depths under 1/10 mm possible

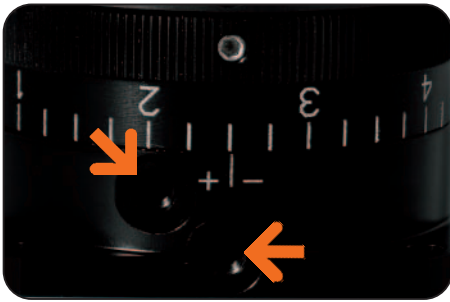

Energy feed

- Only one pneumatic line required for function
- Additional air connection for repelling the workpiece
- Hoseless direct connection possible, no additional interference contours (ST40)

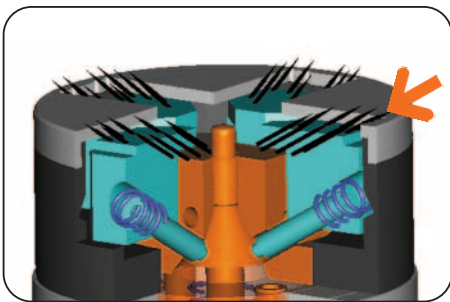

Needle wiper

Helps for wiping the workpiece

- Prevents movement of the workpiece
- Provides defined, smooth cover surface



Fixing and positioning options

- Via four screws axial on the cylinder bottom

Needle Gripper

Needlegripper ST36



Ø 40 mm

Accessory list



Pneumatic fittings
Order no. WVM5

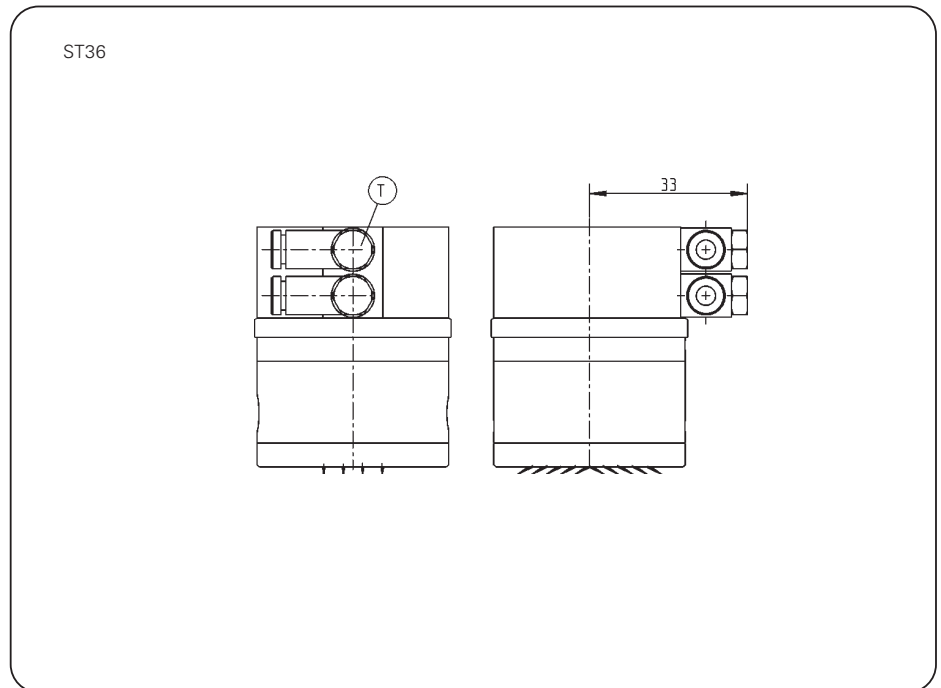

Needlegripper ST40



Ø 60 mm

Accessory list

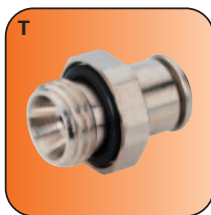

Pneumatic fittings
Order no. GVM5

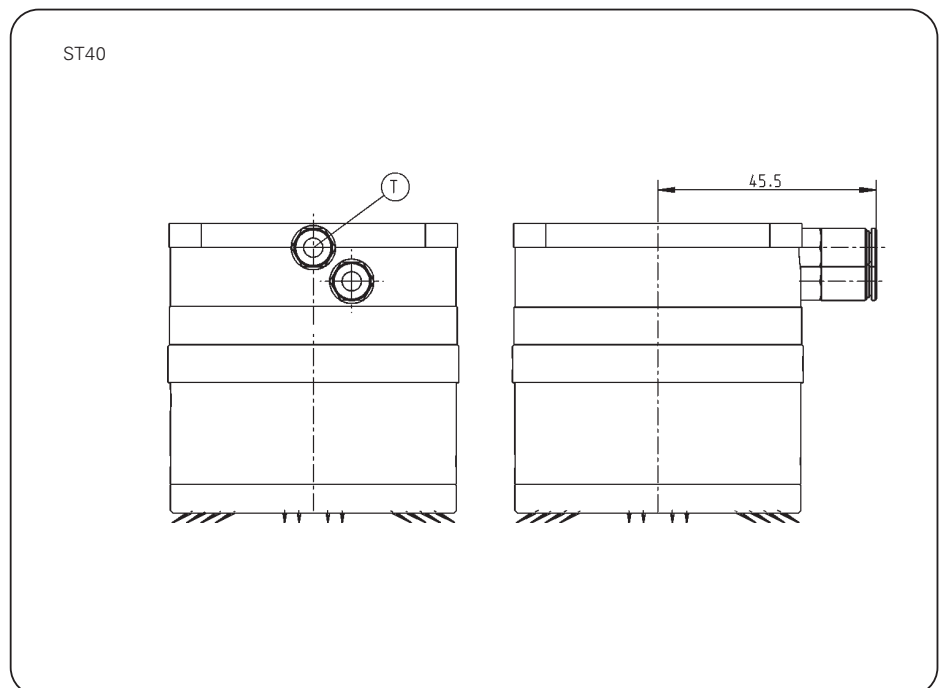

Subject to change without prior notice



Order no.:	ST36	ST40
Stroke adjustable per needle holder [mm]:	0 – 1,5	0 – 2
Number of needles [Pice]:	20	40
Needle diameter [mm]:	0,7	0,7
Gripping force in extraction [N]:	100	160
Retract time/extend time [s]:	0,03	0,03
Repeatability +/- [mm]:	0,1	0,1
Min./max. operating pressure [bar]:	4/8	4/8
Min./max. operating temperature [°C]**:	5/80	5/80
Air volume per cycle [cm ³]:	1	3
Weight [g]:	210	490

All data measured at 6 bar

** High temperature resistant model (up to 150 °C) add „T“ to part number

ST36

- ① Gripper connection
- ② Energy supply
- ⑳ Blowing air
- ㉘ Adjustment ring
- Ⓑ Air connection (extend)

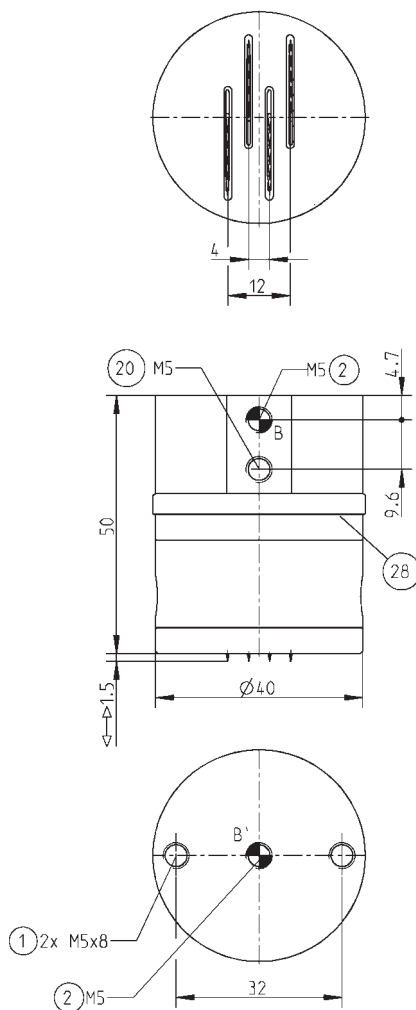

ST40

- ① Gripper connection
- ② Energy supply
- ⑳ Blowing air
- ㉘ Adjustment ring
- Ⓑ Air connection (extend)

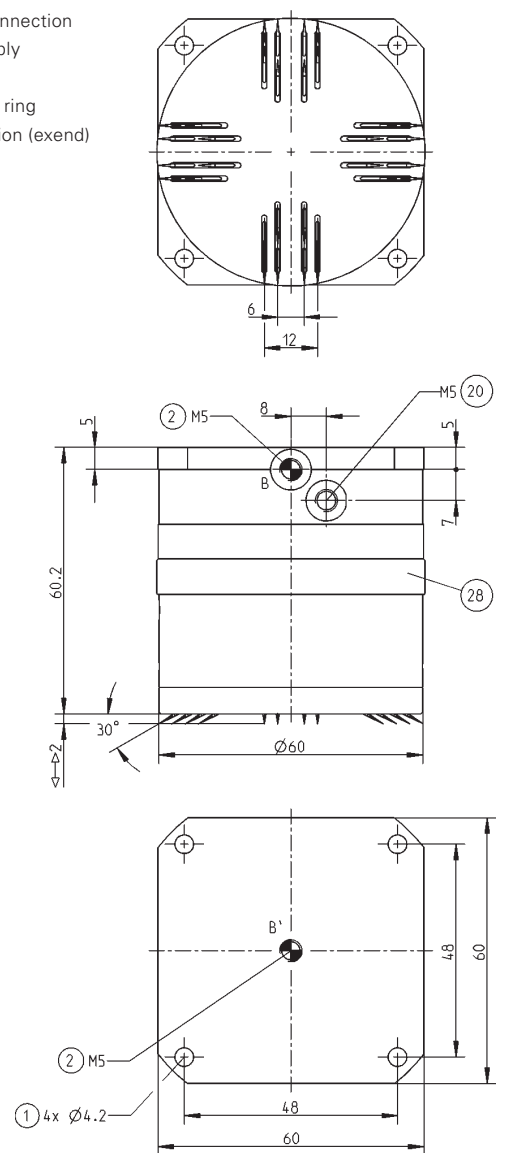

Subject to change without prior notice



Needle Gripper

pneumatic



SCH-Series

SOMMER
automatic

Needle Gripper

➤ Features

- Handling of porous and pressure sensitive materials such as Styropor by penetration with needles
- Adjustable stroke up to 6 mm penetration depth per pair of needles
- Two designs available, needle diameter 1.2 or 3 mm

Functional diagram

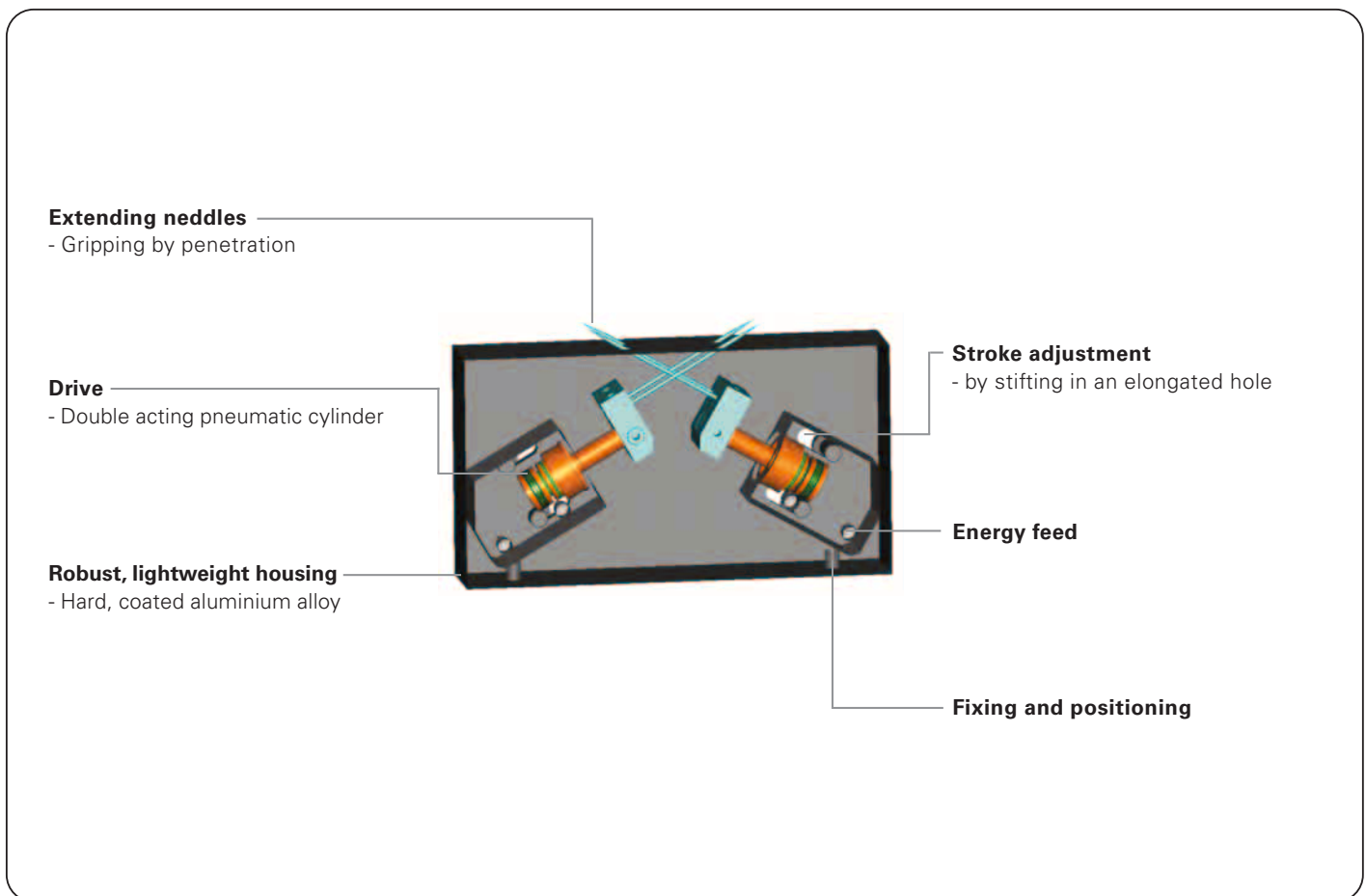



Terms

- Closing-/opening time:** time required by needles to travel the entire stroke distance
- Repeatability:** dispersion of stop positions at 50/100 consecutive cycles/strokes
- Cycles:** distance covered by the piston in one open and close movement
- Maintenance:** maintenance free bis 5 Mio. Zyklen
(please see the owner's manual for conditions,
download from www.sommer-automatic.com)
- long maintenance intervals keep costs down
 - long durability

Model

Order no.	Adjustable stroke up to	Needle diameter	Total force in extend/retract
SCH20	0/6 mm	1,2 mm	35 N/30 N
SCH23	0/6 mm	3 mm	35 N/30 N

Needle Gripper

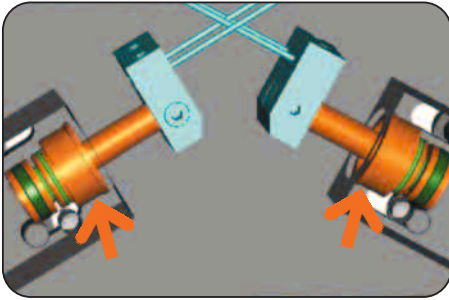

Drive

Two dual effect pneumatic cylinders

- High force when penetration and retract
- Rapid cycle times



Interlocking gripping

- Penetration with four needles under 30° per pair of needles
- Two pairs of needles penetrate in opposite direction

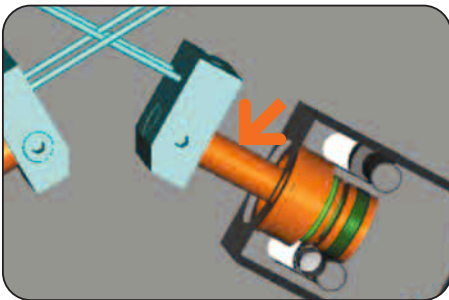

Force transfer

- Direct
- Loss free



Adjustable stroke

By shifting the pneumatic cylinder in an elongated hole

- From 0 to 6 mm
- Infinitely variable
- Flexible

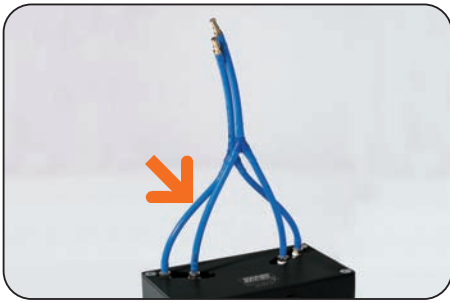

Energy feed

Pneumatic fork hose included in the delivery

- Simultaneous air supply for both pneumatic cylinders
- Synchronize penetration of both pairs of needles
- Low effort for the installation of the pneumatic lines



Needles

Gripping needles fixed in the needle holder

- Spare needles included in the delivery
- Easy to replace needles
- Short maintenance time
- Cost-effective needle changing

Needle Gripper

Needle Gripper SCH20



Included in the delivery

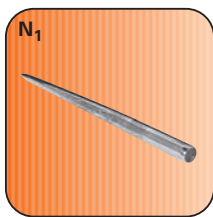

Spare needle
Order no. CNAD00200



Pneumatic face hose
Order no. PYA

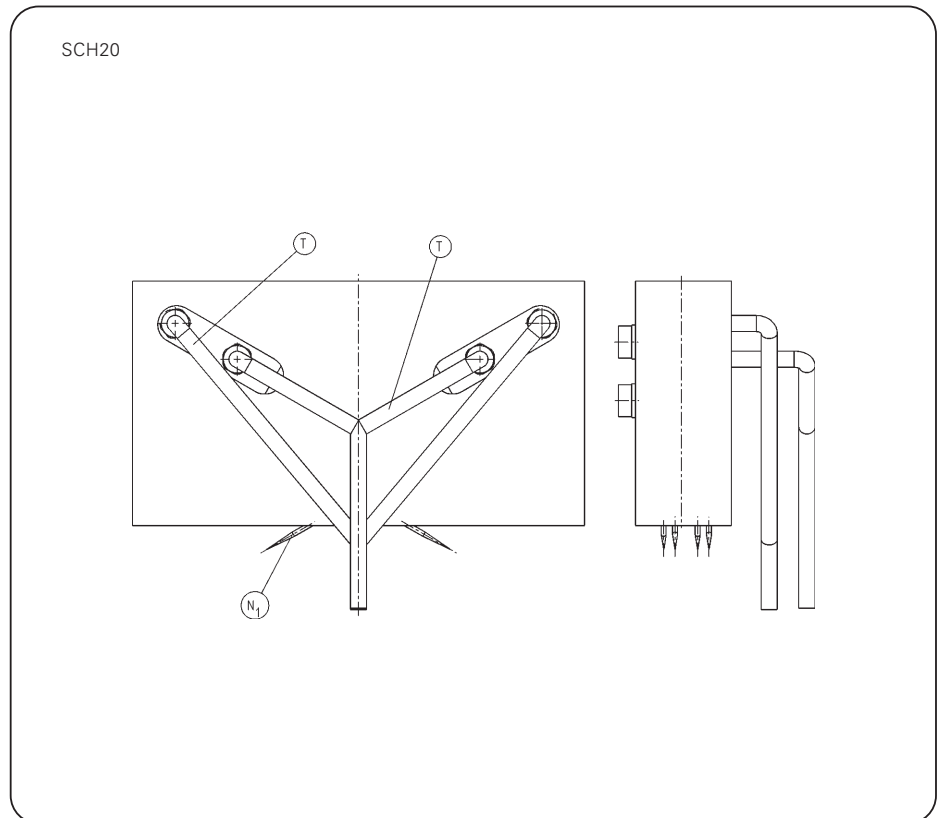

Needlegripper SCH23

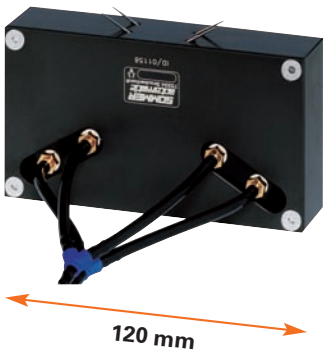

Included in the delivery

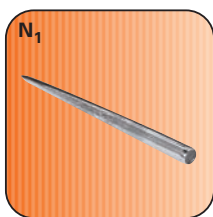

Spare needle
Order no. CNAD00230



Pneumatic face hose
Order no. PYA

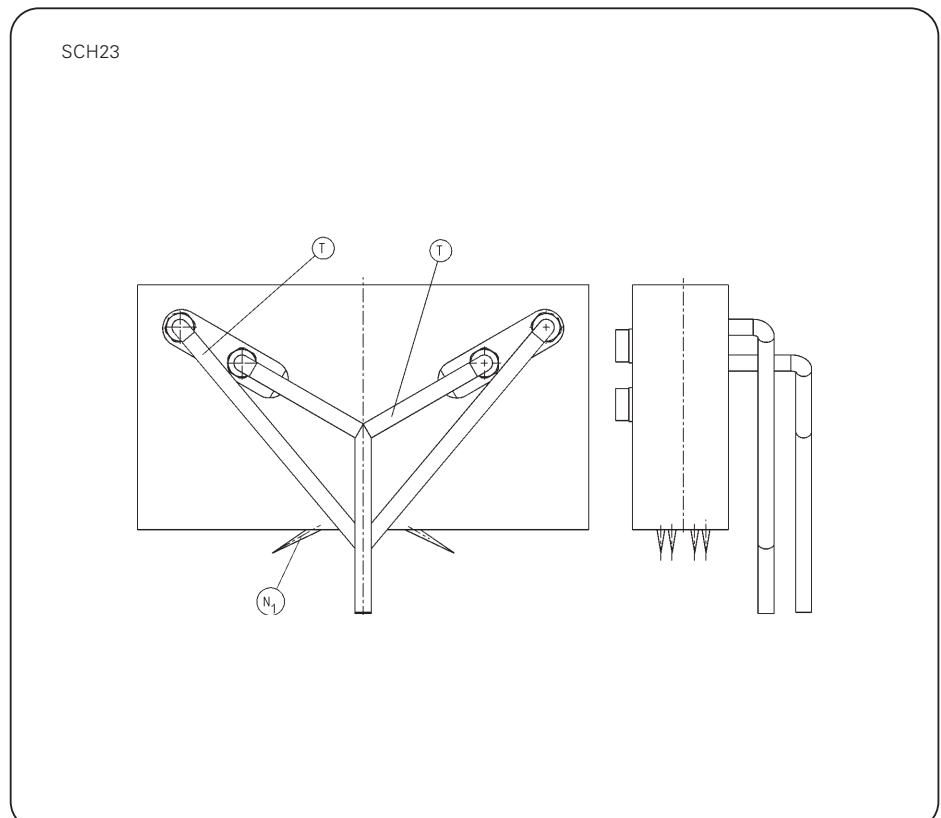

Subject to change without prior notice

Order no.:	SCH20	SCH23
Adjustable stroke [mm]:	0-6	0-6
Number of needles [Stück]:	4	4
Needle diameter [mm]:	1,2	3
Gripping force when extraction [N]:	35	35
Retract time/extend time [s]:	0,02	0,02
Repeatability +/- [mm]:	0,02	0,02
Min./max. operating pressure [bar]:	4/8	4/8
Min./max. operating temperature [°C]**:	5/80	5/80
Air volume per cycle [cm ³]:	5	5
Weight [g]:	350	370

All data measured at 6 bar

** High temperature resistant model (up to 150 °C) add „T“ to part number

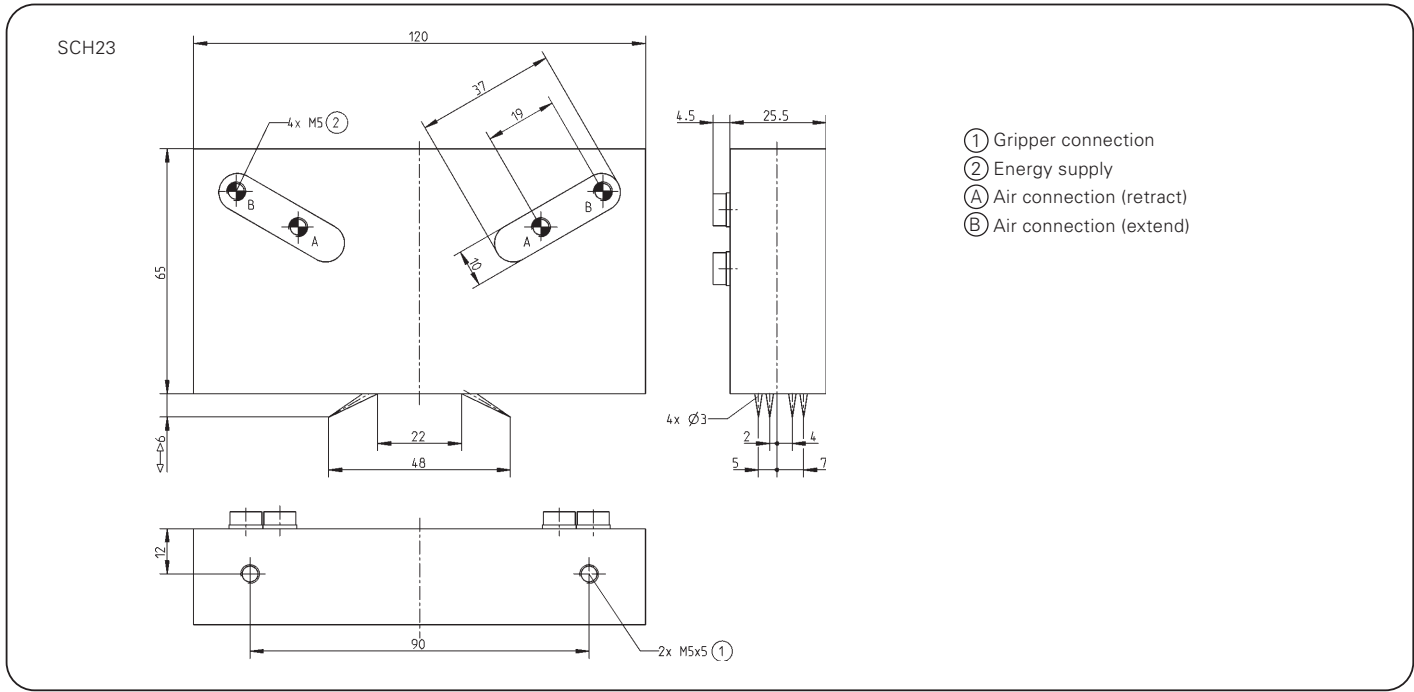
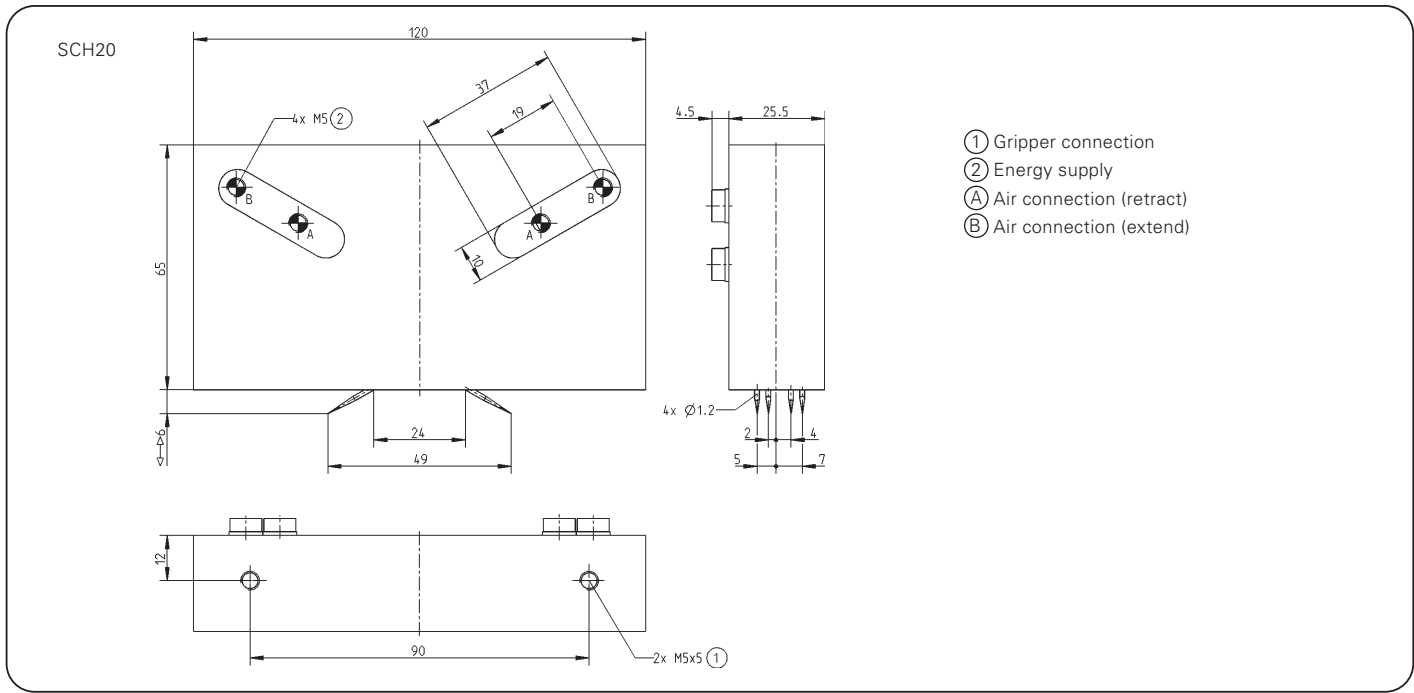

Subject to change without prior notice



O-Ring assembly **Gripper** *pneumatic*



GS-Series

SOMMER
automatic

O-Ring assembly **Gripper**

➤ Features

- Handling for O-rings and various seal rings (e.g. quad rings) of \varnothing 4 – 150 mm
- Adjustable opening stroke of 1.6 – 10 mm
- Multiple function: expanding and ejector

Functional diagram

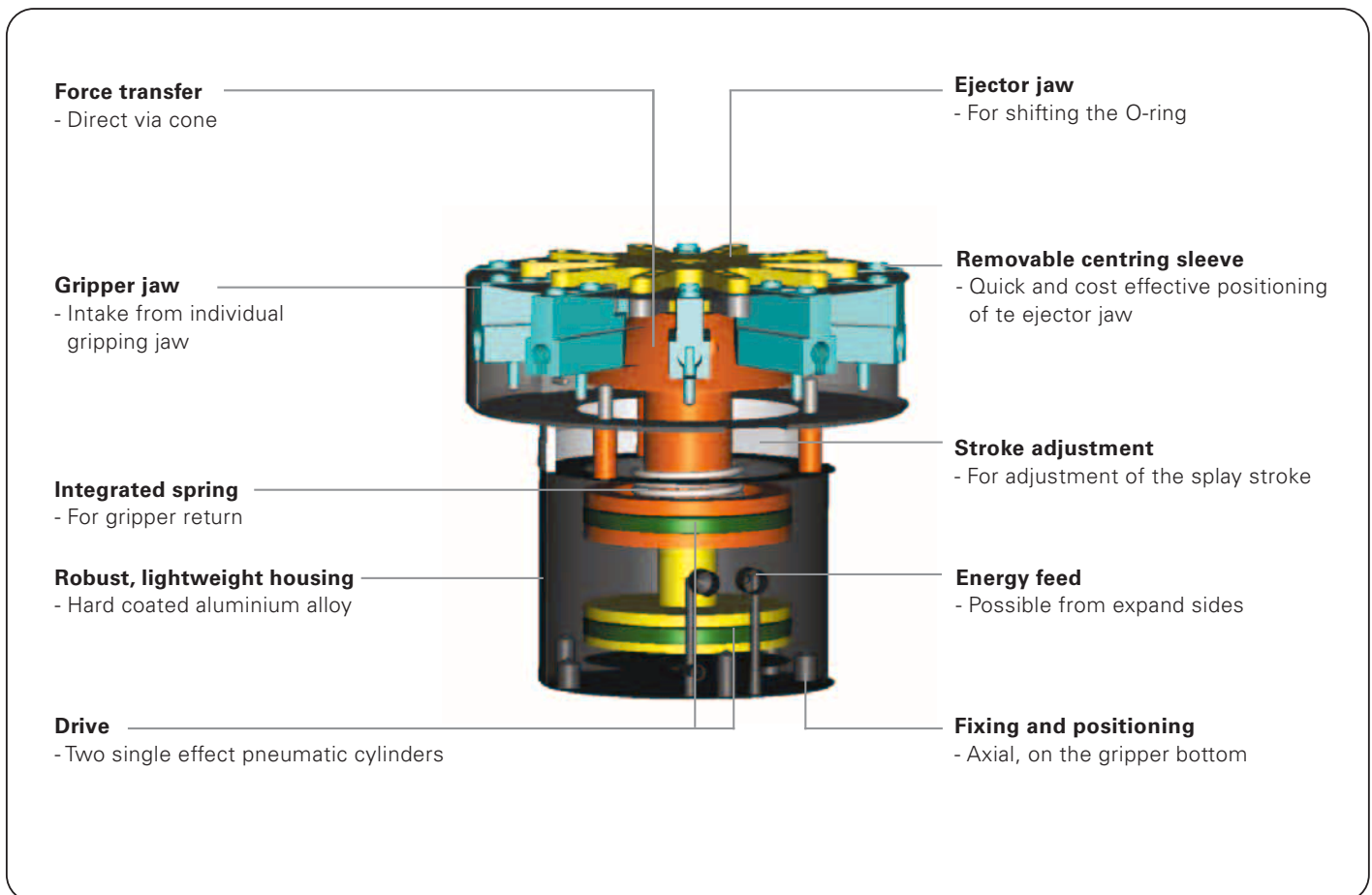

Terms

- Gripping force:** arithmetic sum of the individual forces occurring at the jaws
- Closing-/opening time:** time required by the gripping jaw to travel the entire stroke distance
- Repeatability:** dispersion of stop positions at 50/100 consecutive cycles/strokes
- Cycle:** distance covered by the piston in one open and close movement
- Maintenance:** maintenance free bis 5 Mio. Zyklen
(please see the owner's manual for conditions, download from www.sommer-automatic.com)
 - long maintenance intervals keep costs down
 - long durability

Model

Order no.	Suitable for O-Ring ISO 3601-1	Splay stroke adjustable per jaw	Expanding	Ejector
GS65	Innendurchmesser 4 – 60 mm	3 mm – 6 mm	300 N	5 mm
GS1015	Innendurchmesser 40 – 150 mm	1,6 mm – 10 mm	1450 N	15 mm

Function

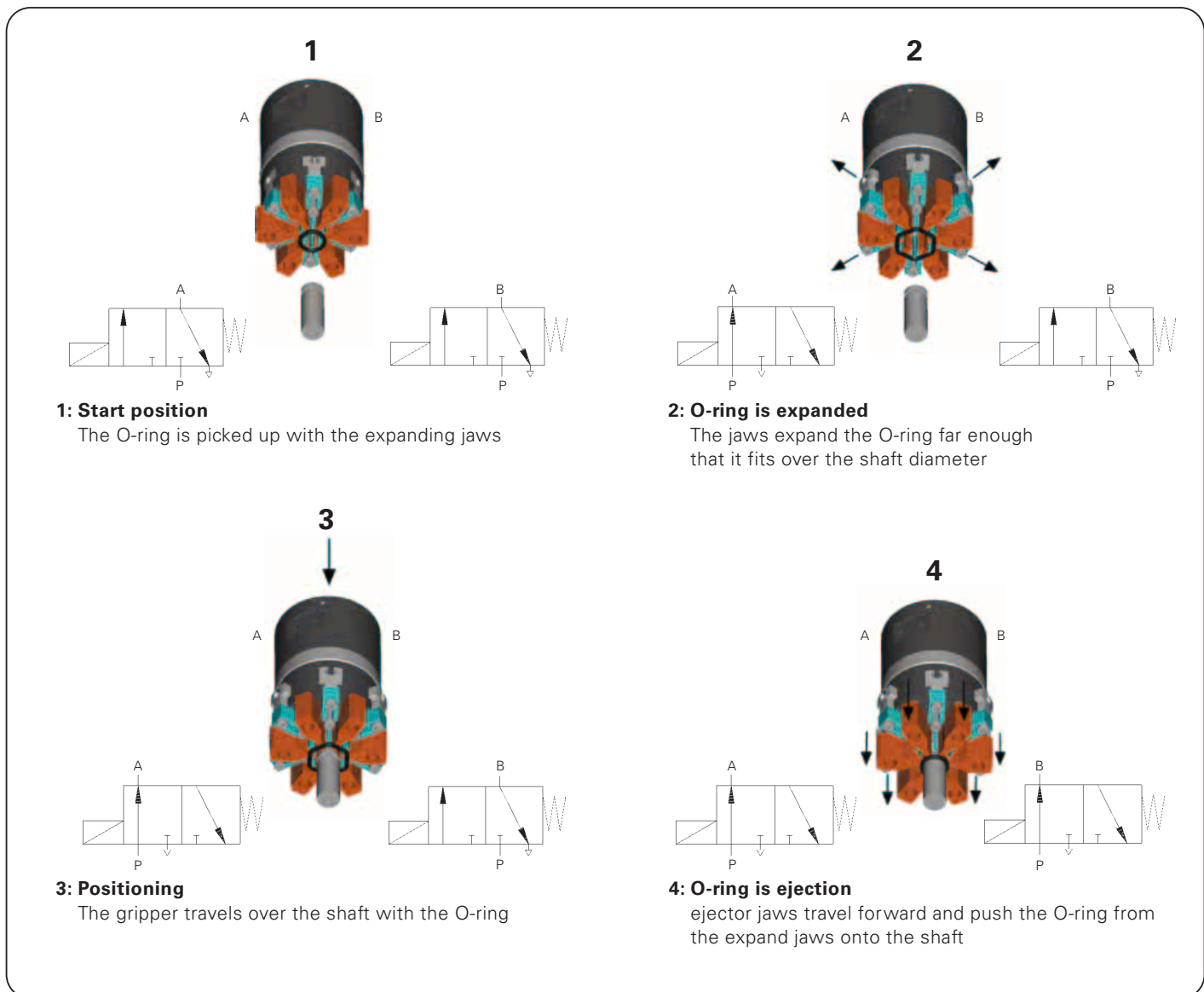

O-Ring assembly **Gripper**

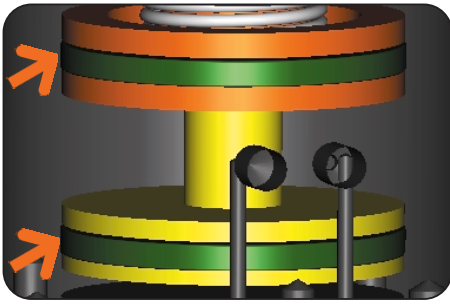

Drive

Two single effect pneumatic cylinders

- Each cylinder controlled by a 3/2 or 5/3 way valve
- Return by spring



Guide

T-slot expanding jaw guide

- T-slot guide for high force and torque intake
- High precision due to low play design

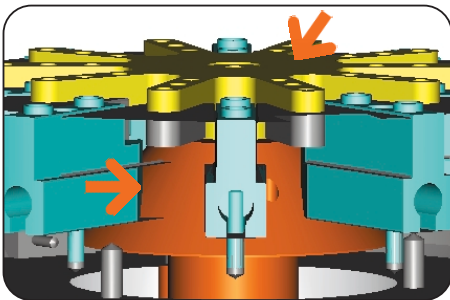

Force transfer

Expanding stroke via hardened steel cone

Linear ejector stroke

- Direct and low loss



Expanding stroke

adjustable from outside via adjusting ring

- prevents overstretching of the O-ring
- individually
- flexibel
- customised

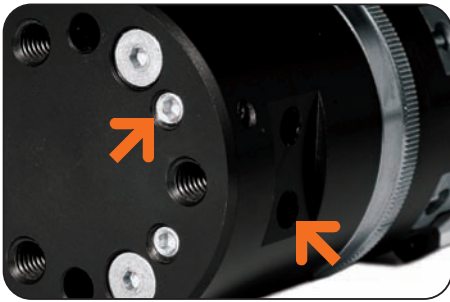

Energy feed

Flexibility possible on several sides

- Optimum integration in the workspace due to individual installation position
- Hoseless direct connection possible (no additional interference contours)

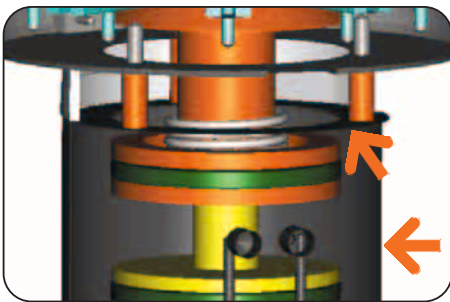

Housing in hard anodised aluminium

Light and resistant

Working parts in nitrated steel

Low wear



Accessories

Prefabricated standard jaws

- Cheap
- Usable immediately
- No production effort

O-Ring assembly **Gripper**



Ø 50 mm

Included in the delivery



Centering sleeves
Order no. **BDST06510**

Accessory list

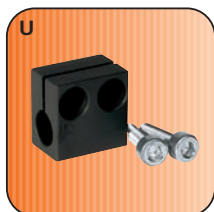

Mounting block
Order no. **KB6.5-02**

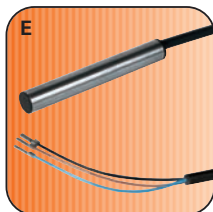

Proximity switch
Order no. **NJ6.5-E2**



Pneumatic fittings
Order no. **WVM5**

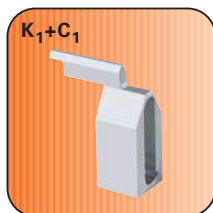

Expanding jaws
Order no. **UB65-1 (Al)**
Order no. **UB65-4 (St)**
for O-ring Ø 4-20 mm



Universal jaws
Order no. **UB65-2 (Al)**
for O-ring Ø 20-60 mm

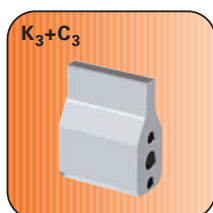

Ejector jaws
Order no. **UB65-3 (Al)**

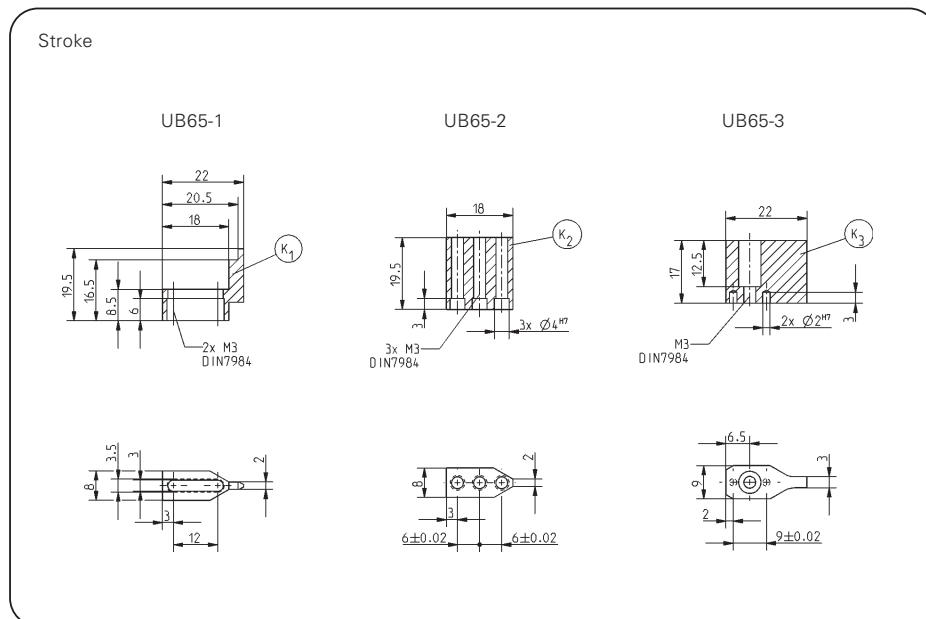
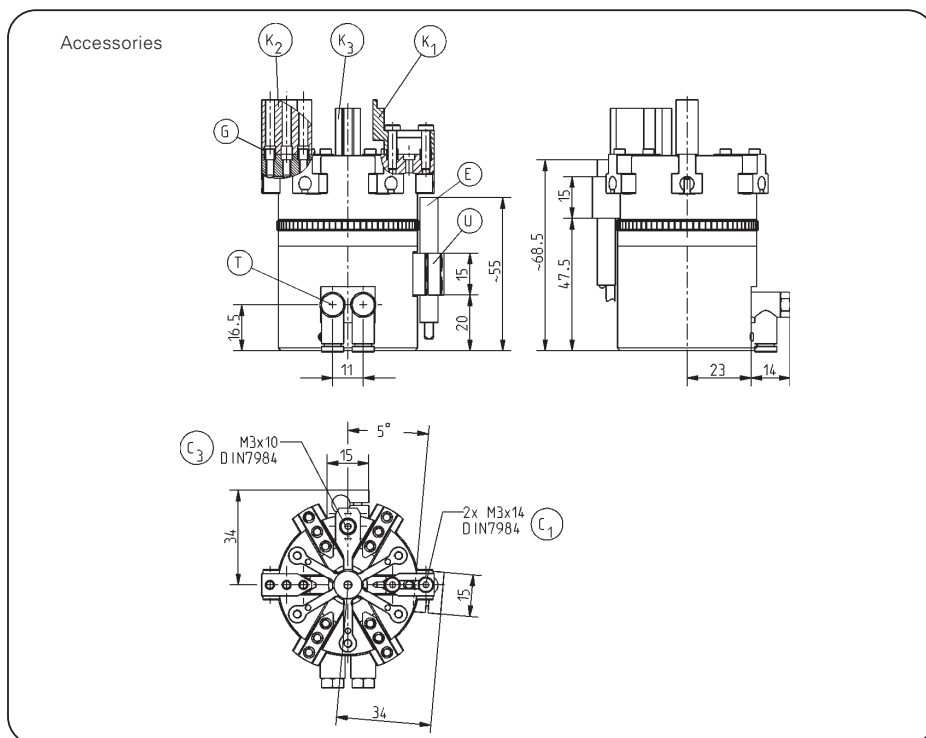

Subject to change without prior notice

Order no.:	GS65
Opening stroke adjustable per jaw [mm]:	3 – 6
Stipping stroke [mm]:	5
Opening force [N]:	300
Recommendet O-ring diameter [mm]:	4 – 60
Number of gripping jaws:	6
Closing time/opening time [s]:	0,05
Repeatability +/- [mm]:	0,1
Min./max. operating pressure [bar]:	4/8
Min./max. operating temperature [°C]**:	5/80
Weight [g]:	500

All data measured at 6 bar

** High temperature resistant model (up to 150 °C) add „T“ to part number

GS65

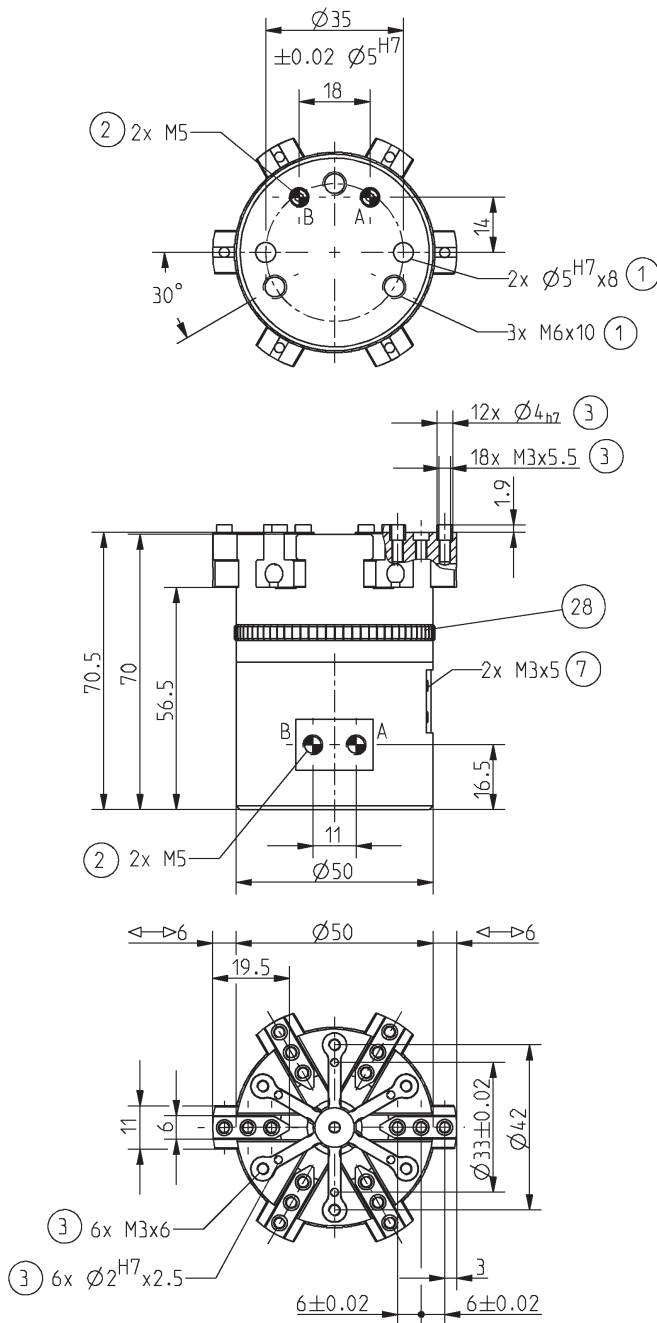

- ① Gripper connection
- ② Energy supply
- ③ Connection for jaw
- ⑦ Fixing for mounting block (KB)
- A Air connection (expanding stroke)
- B Air connection (ejector stroke)
- A Air connection alternate (expanding stroke)
- B Air connection alternate (ejector stroke)

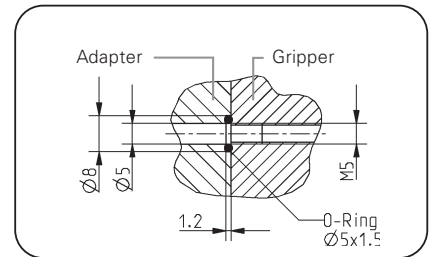

Hoseless air connection

Subject to change without prior notice

O-Ring assembly **Gripper**



Included in the delivery

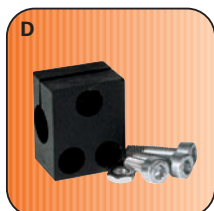

D
Mounting block
Order no. KB8K



G
Centering sleeves
Order no. BDST60800

Accessory list



E
Proximity switch
Order no. NJ8-E2S



T
Pneumatic fittings
Order no. WV1/8x8



K₁+C₁
Expanding jaws
Order no. UB1015-1 (Al)
Order no. UB1015-4 (St)
for O-ring ø 40-80 mm



K₂
Universal jaws
Order no. UB1015-2 (Al)
for O-ring ø 50-150 mm

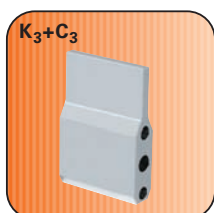

K₃+C₃
Ejector jaws
Order no. UB1015-3 (Al)



Cable angled plug
Order no. KAW500

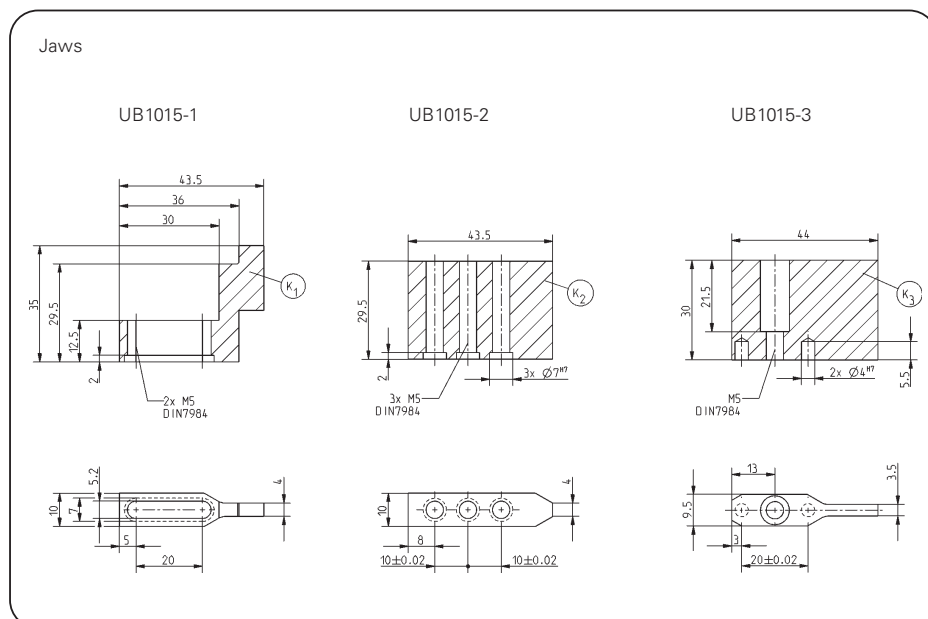
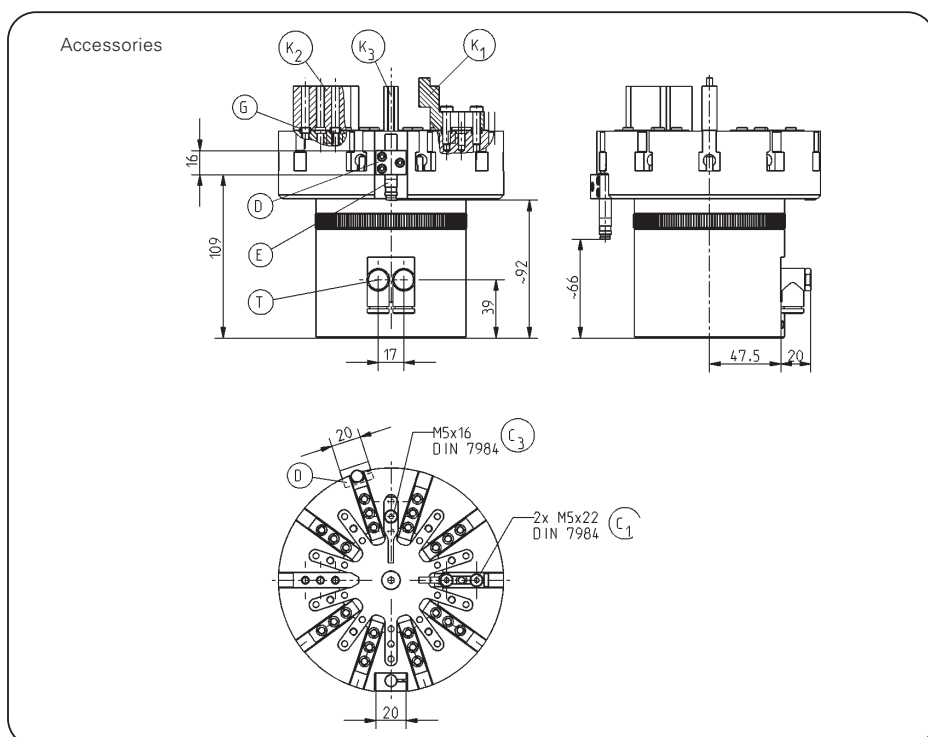

Subject to change without prior notice

Order no.:	GS1015
Opening stroke adjustable per jaw [mm]:	1,6 – 10
Stipping stroke [mm]:	15
Opening force [N]:	1450
Recommendet O-ring diameter [mm]:	40 – 150
Number of gripping jaws:	10
Closing time/opening time [s]:	0,05
Repeatability +/- [mm]:	0,1
Min./max. operating pressure [bar]:	3/8
Min./max. operating temperature [°C]**:	5/80
Weight [g]:	5,4

All data measured at 6 bar
 ** High temperature resistant model (up to 150 °C) add „T“ to part number

GS1015

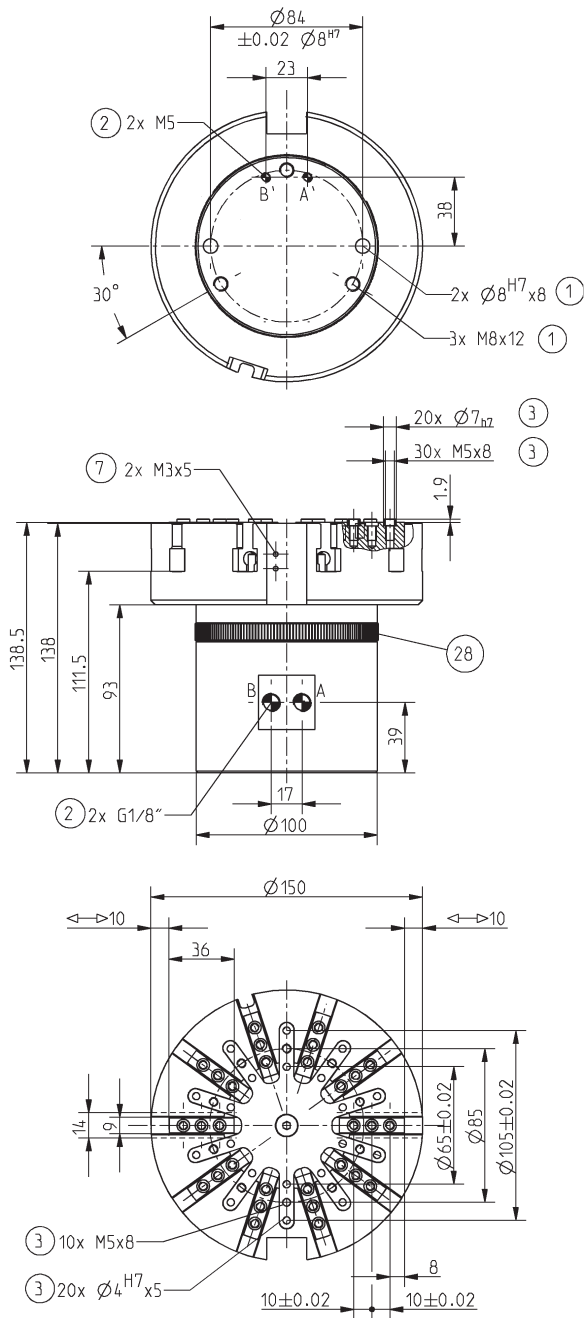

- ① Gripper connection
- ② Energy supply
- ③ Connection for jaw
- ⑦ Fixing for mounting block (KB)
- Ⓐ Air connection (expanding stroke)
- Ⓑ Air connection (ejector stroke)
- Ⓐ Air connection alternate (expanding stroke)
- Ⓑ Air connection alternate (ejector stroke)

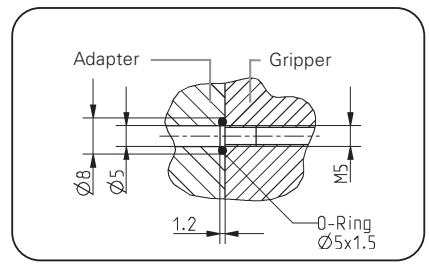

Hoseless air connection

Subject to change without prior notice



Cutting **Tongs**

pneumatic



ZK Series

SOMMER
automatic

Cutting Tongs

Features

- Cutting tongs for severing or removing gatings, wire or cable
- High gripping force up to 6800 N due to high force transmission
- Available in two sizes with stroke of up to 9° per jaw

Functional schematic

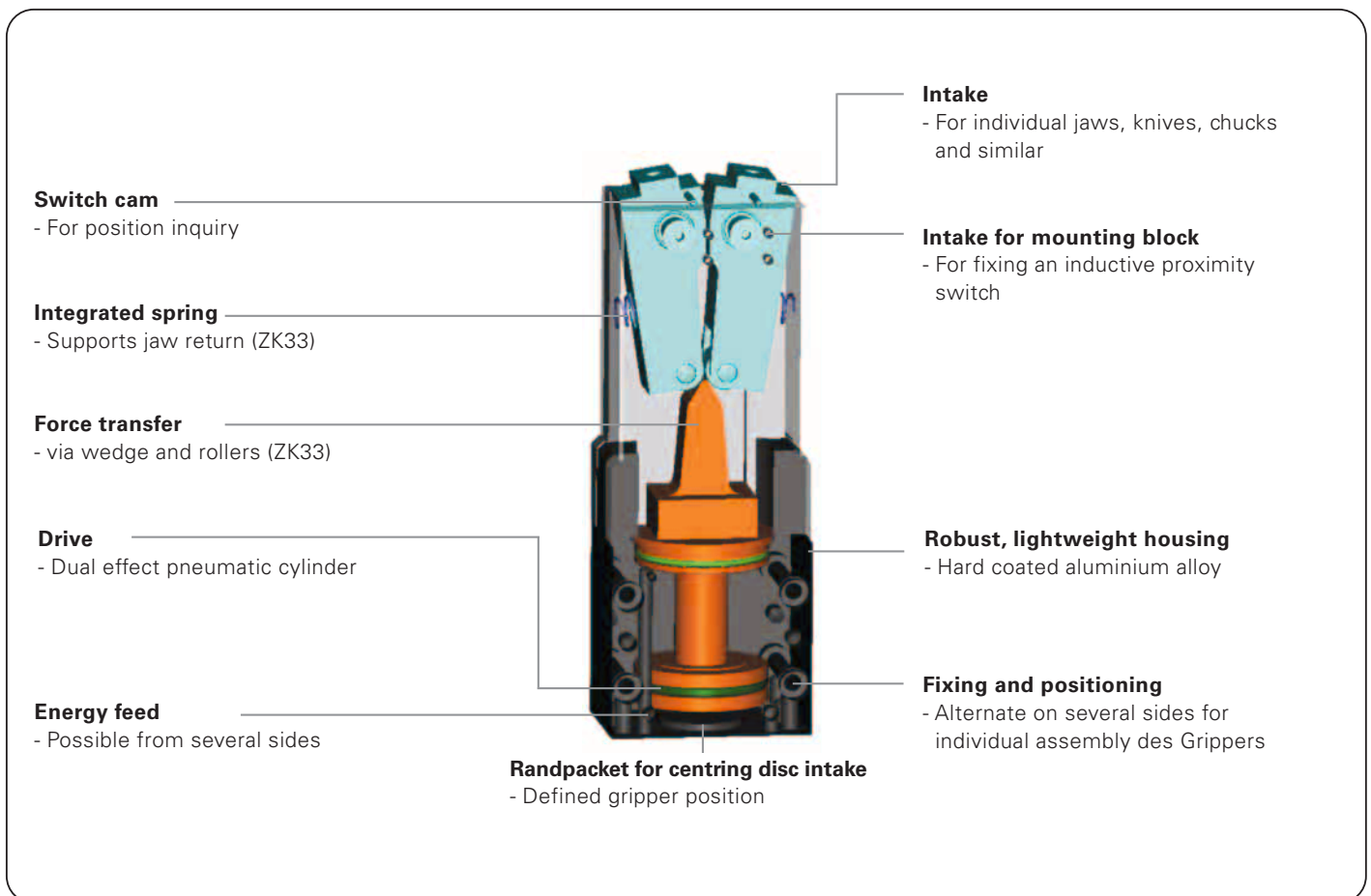



Terms

- Gripping force:** arithmetic sum of the individual force occurring at the jaws
- Closing-/opening time** time required by the gripper jaw to travel the entire stroke distance
- Repeatability:** dispersion of stop positions at 50/100 consecutive cycles/strokes
- Gripping force safety:** mechanical Self-limitation at 0° opening angle via knee lever principle (ZK22).
Via pressure safety valve (Order no. DSV1/8), which prevents loss of tension force if there is a drop in pressure. The leakage in the pneumatic circuit restricts the time of this type of gripping force safety (ZK22/ZK33).
- Cycle:** distance covered by the piston in an open and close movement
- Maintenance:** maintenance free bis 5 Mio. cycles
(please see the owner's manual for conditions, download from www.sommer-automatic.com)
- long maintenance intervals keep costs down
 - long durability

Model

Order no.	Stroke per jaw	Force stroke per jaw	Total force in closing	
ZK22	7,5°	-	3.600 N	
ZK33	9°	2°	6.800 N	

This wire thicknesses can be cut				
Order no.	Copper wire	Brass wire	Steel wire (ST52)	Max. Cutter length from top edge of housing
ZK22	3,5 mm	3 mm	2 mm	25 mm
ZK33	6 mm	5 mm	4 mm	35 mm

Cutting Tongs

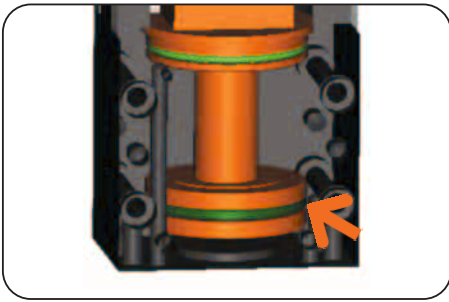

Drive

Double acting pneumatic cylinder

- Maximum drive force when opening and closing
- Gripping force up to 6800 N



Accessories

Three different cutting knives in high performance high speed steel (X155CrVMo121)

- Ready for use immediately
- No additional production effort
- Can be aligned in the holder
- Can be resharpened

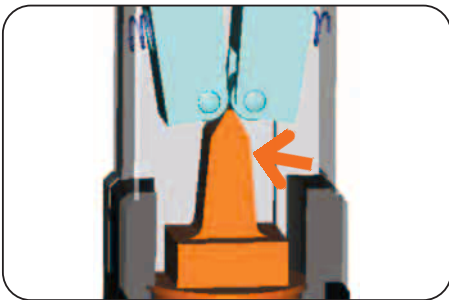

Force transfer

Positively drive lever transmission (ZK22) or coil and rollers (ZK33)

- Optimum transmission of drive force in gripping force
- Self-centering
- Synchronisation
- High repeatability



Machine connection

- Installation location as desired
- Optimum use of space ratios



Energy feed

Flexibility possible on several sides

- Optimum integration in the workspace due to individual installation position
- Hoseless direct connection possible (no additional interference contours)

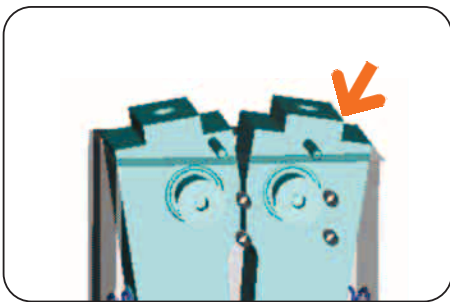

Intake

For individual jaws, knives or standard accessories

- Low design effort
- High repeat accuracy
- Precise position

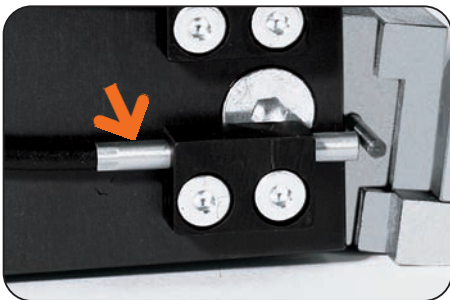

Position sensing

Switch cam on jaws for position recognition

- Process safe
- Compact
- For inductive switches with 3 mm Ø

Cutting Tongs



Gripping force diagram

Shows the gripping torque as a function of the opening angle.



Shows the gripping force as a function of the jaw length (measured at 1° opening angle).

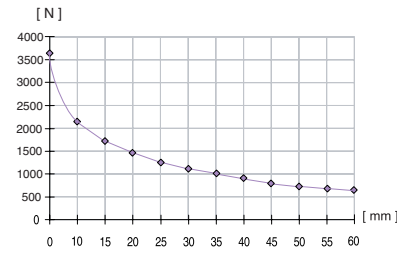

measured from top edge of gripper jaw

Forces and Moments

Max. allowable forces and moments on jaws

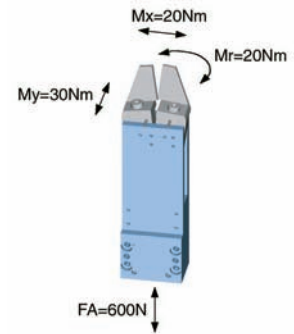

Accessory list

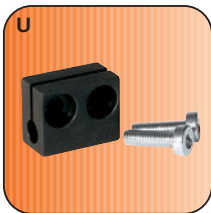

Mounting block
Order no. KB3

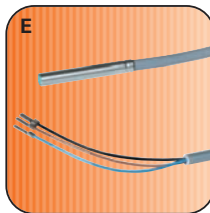

Proximity switch
Order no. NJ3-E2



Pneumatic fittings
Order no. WVM5



Universal jaws
Order no. UB22



Dual cutters with double ground cutting edges
Order no. BK22-1

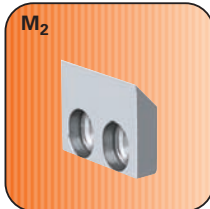

Cutters with plane/ground cutting edge
Order no. BK22-2



Cutter with shearing blades
Order no. BK22-3



Cutter intake
Order no. BK22



Centring disc
Order no. ZE20H7x4



Plug 3-pole
Order no. S12-G-3

Accessories

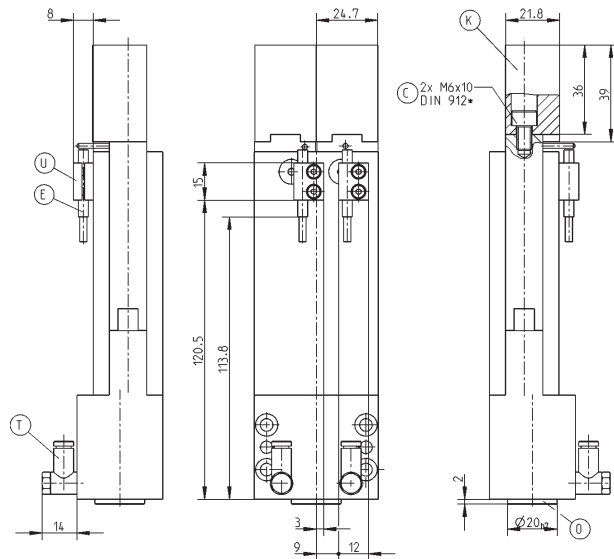

Cutter

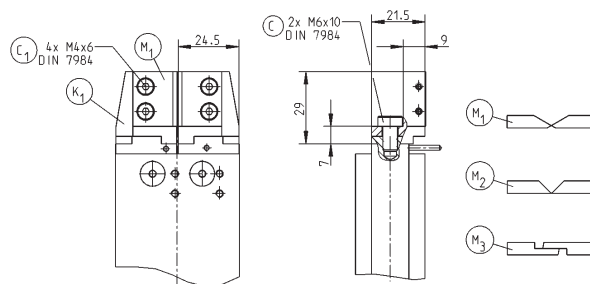

Subject to change without prior notice

Order no.:	ZK22
Stroke per jaw [°]:	7,5
Gripping torque in closing [Nm]*:	54
Gripping force in closing [N]:	3600
Closing time/opening time [s]:	0,15
Repeatability +/- [mm]:	0,1
Min./max. operating pressure [bar]:	3/8
Min./max. operating temperature [°C]**:	5/80
Air volume per cycle [cm ³]:	10
Weight [g]:	790

All data measured at 6 bar
 * measured at 2° opening angle
 ** High temperature resistant model (up to 150 °C) add „T“ to part number

ZK22

- ① Gripper connection
- ② Energy supply
- ③ Fixing jaw/cutter
- ⑦ Fixing for mounting block (KB)
- Ⓐ Air connection (closing)
- Ⓑ Air connection (opening)
- Ⓐ' Alternate air connection (closing)
- Ⓑ' Alternate air connection (opening)

* replaced by DIN EN ISO 4762

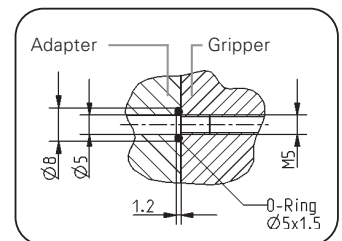
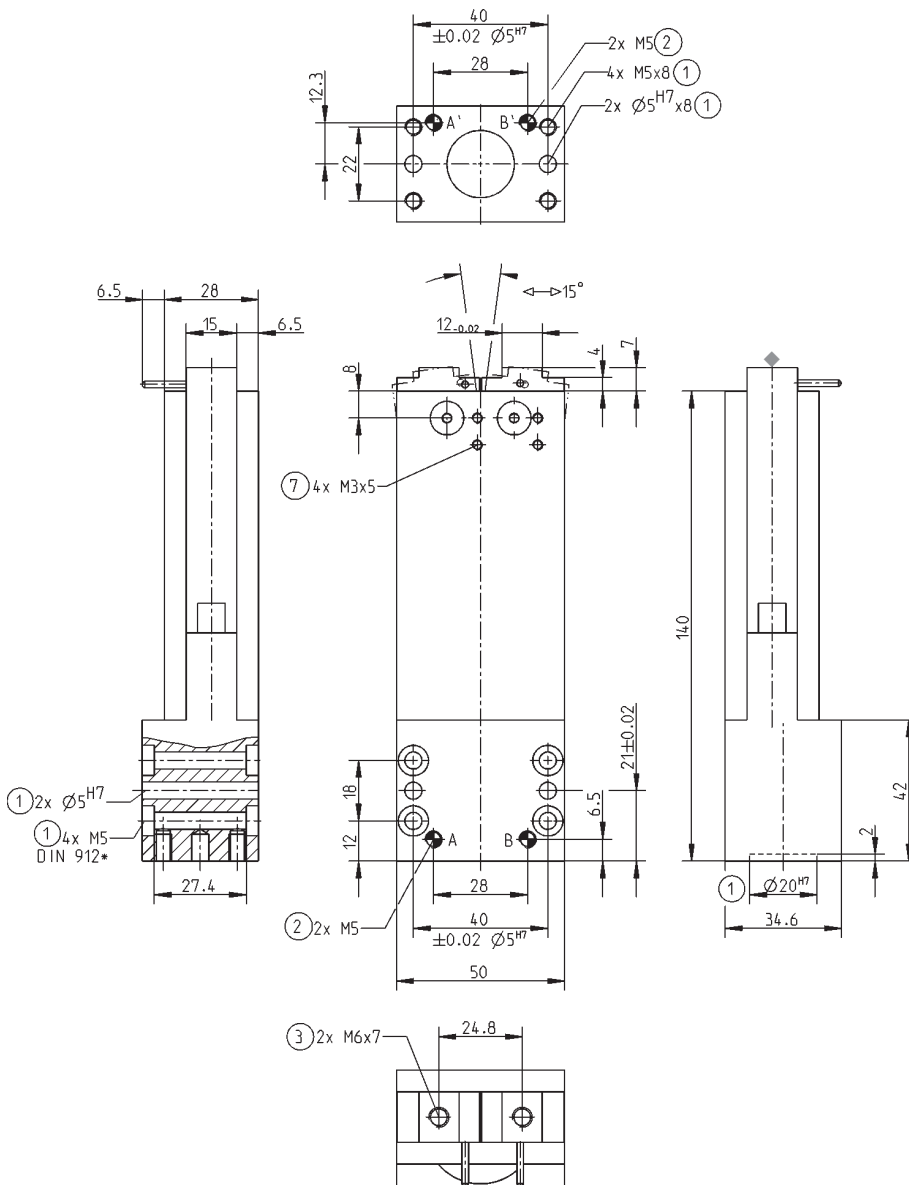

Hoseless air connection

Subject to change without prior notice



Tube Gripper

pneumatic



RG-Series

SOMMER
automatic

Tube Gripper

➤ Features

- Available in two sizes for cylindrical workpieces with \varnothing up to 58 mm
- Gripping force can be regulated via operating pressure between 1 and 3 bar for max. 1000 N gripping force
- High friction value due to direct gripping with a rubber membrane

Functional diagram

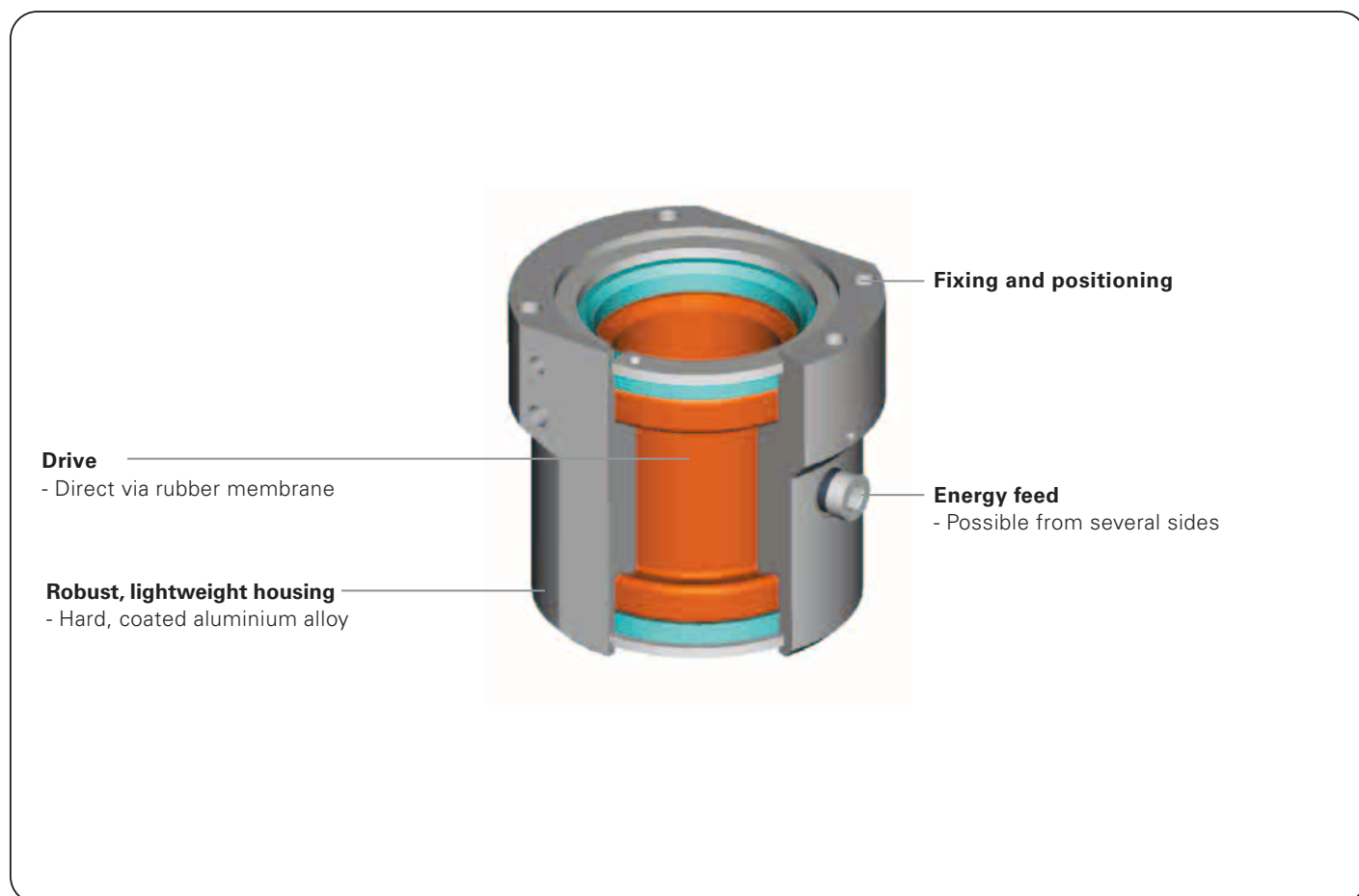

Terms

- Closing-/opening time:** time required by rubber membrane to travel the entire stroke distance
- Repeatability:** dispersion of stop positions at 50/100 consecutive cycles/strokes
- Cycle:** distance covered by the membrane in one open and close movement
- Maintenance:** maintenance free
(please see the owner's manual for conditions,
download from www.sommer-automatic.com)

Model

Order no.	Gripping diameter min./max.	Gripping force in closing
RG0-30	0/28 mm	350 N
RG10-60	10/58 mm	1000 N

Tube Gripper

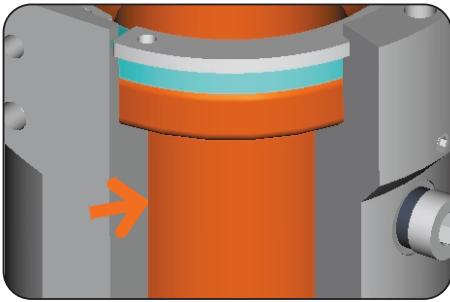

Drive

single effect rubber membrane

- Low steering effort
- Only one pneumatic line required
- Automatic return when venting



Gripping of cylindrical workpieces

- For workpiece diameters up to 58 mm
- Membrane closes in a star shape at 3 points
- No metallic contact

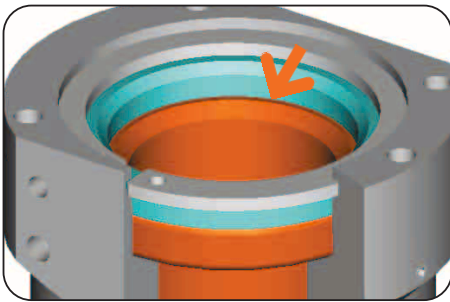

Force transfer

Via rubber membrane

- Direct
- Low loss
- Optimum friction value

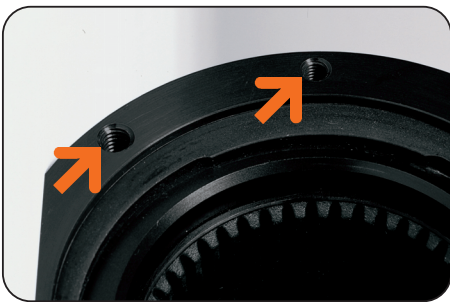

Energy feed

Flexibility possible on several sides

- Hoseless direct connection possible (no additional interference contours)



Simple maintenance

- Quick change of gripping membrane
- Fixed by lock ring
- Short maintenance times

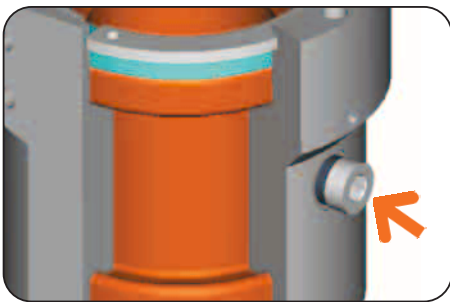

Regulable gripping force

Via operating pressure between 1 and 3 bar

- Flexible
- Protective
- Up to max. 1000 N



Fixing and positioning options

- Simple integration into the workspace due to individual installation position

Tube Gripper

Tube gripper RG0-30



Accessory list



Pneumatic fittings
Order no. GVM5



Pneumatic fittings
Order no. WVM5

Accessories

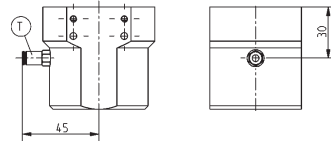

Tube gripper RG10-60



Accessory list



Pneumatic fittings
Order no. GVM5



Pneumatic fittings
Order no. WVM5

Accessories

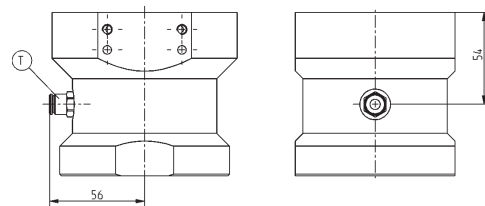

Subject to change without prior notice



Order no.:	RG0-30	RG10-60
Gripping diameter min./max. [mm]:	0-28	10-58
Gripping force in closing [N]:	350	1000
Closing time/opening time [s]:	0,1	0,1
Repeatability +/- [mm]:	0,1	0,1
Min./max. operating pressure [bar]:	1/3	1/3
Min./max. operating temperature [°C]**:	5/80	5/80
Air volume per cycle [cm ³]:	5	33
Weight [g]:	278	845

All data measured at 3 bar/jaw

** High temperature resistant model (up to 150 °C) add „T“ to part number

RG0-30

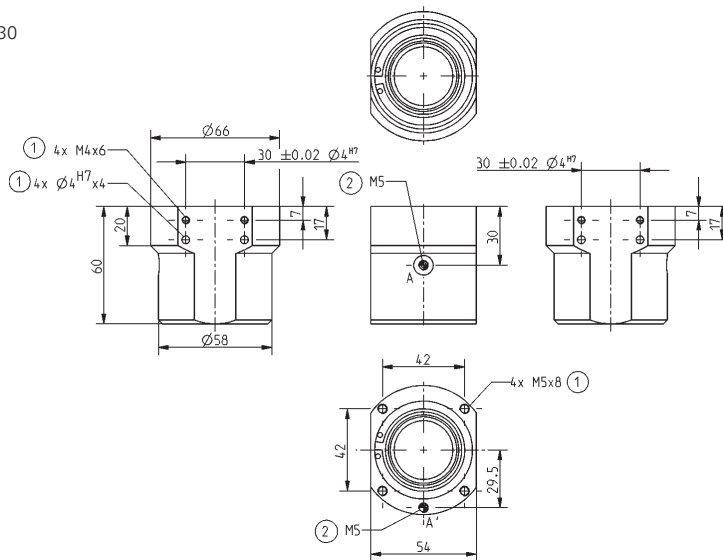

- ① Gripper connection
- ② Energy supply
- Ⓐ Air connection (closing)

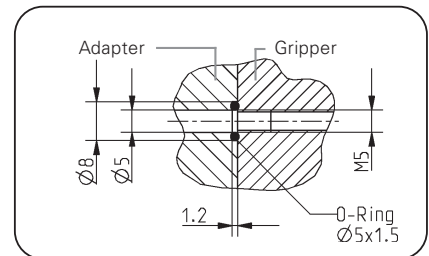

Hoseless air connection

RG10-60

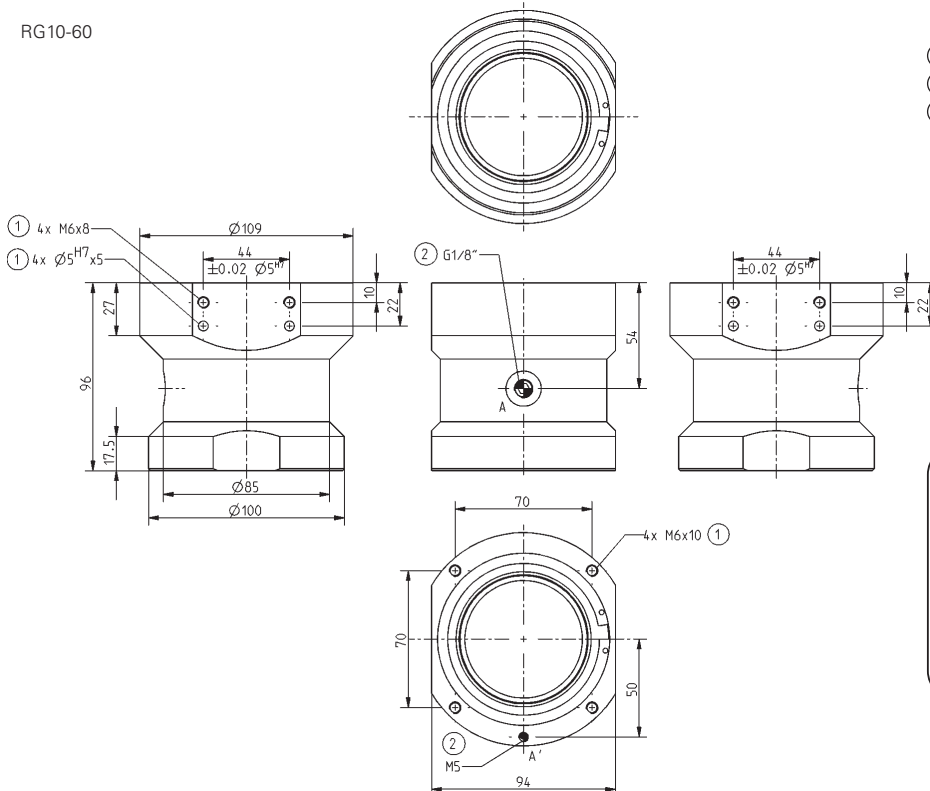

- ① Gripper connection
- ② Energy supply
- Ⓐ Air connection (closing)

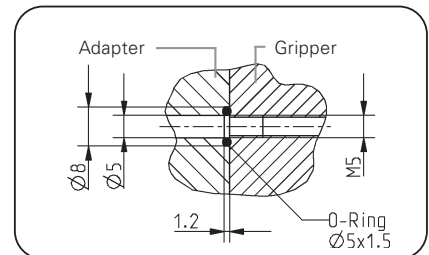

Hoseless air connection

Subject to change without prior notice



Parallel Grippers

sealed with tool intake



GFP2012NC

SOMMER
automatic

Parallel gripper with tool intake

➤ Features

- Drive via the tool machine coolant supply
- Adjustable gripping force via regulable, intergrated spring
- Standardised tool intake

Functional diagram

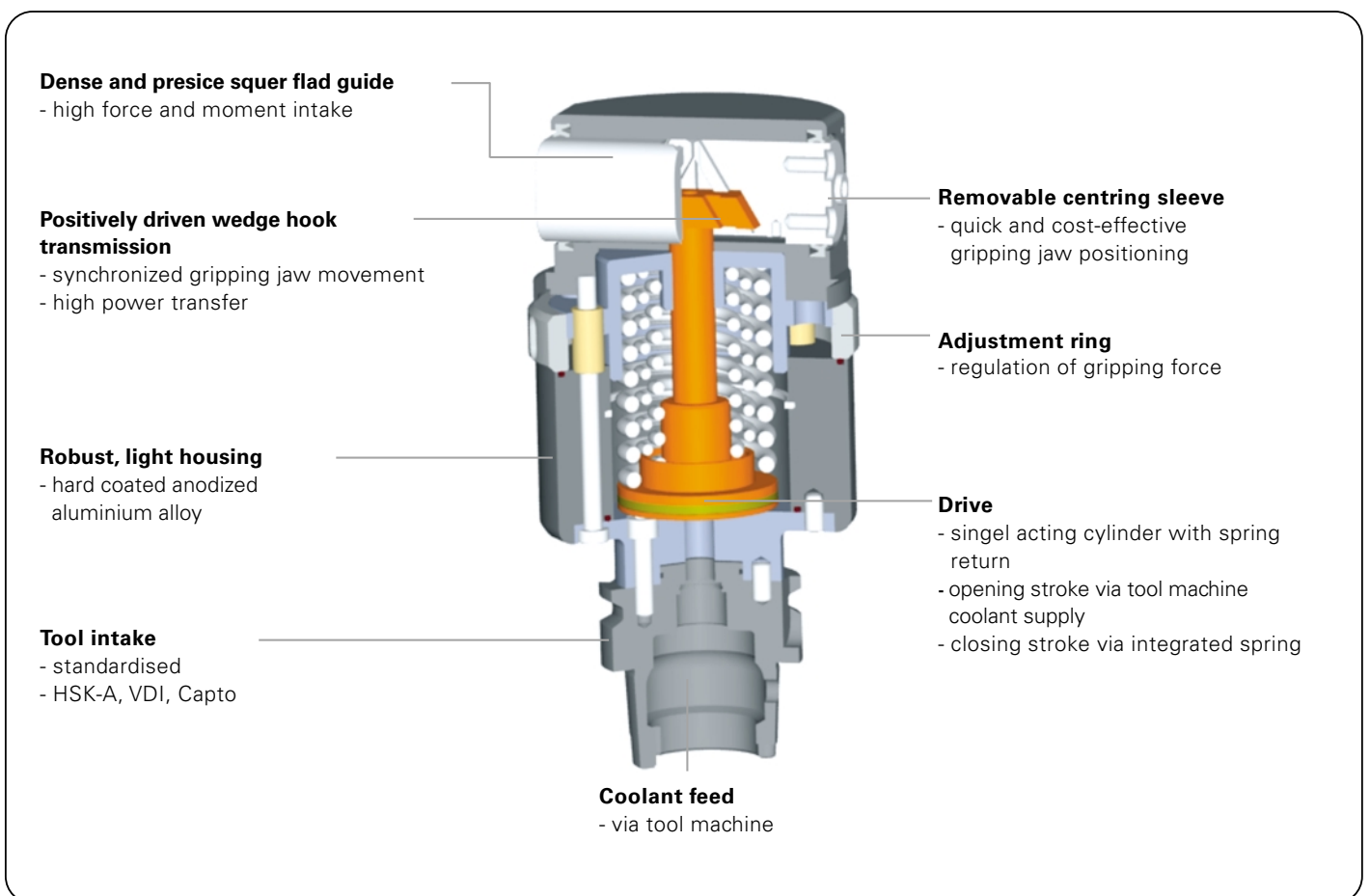

Terms

- Gripping force:** arithmetical sum of the individual forces occurring on the gripping jaws
- Closing time/opening time:** time required by the gripping jaws to travel the entire stroke distance
- Repeatability:** dispersion of stop positions at 50/100 consecutive cycles/strokes
- Cycle:** path travelled by the piston in one open and close movement
- Maintenance:** maintenance free up to 5 Mio. cycles
(please see the owner’s manual for conditions, download from www.sommer-automatic.com)
 - long maintenance intervals keep costs down
 - long durability

Model guide

Order no.	Tool intake	Gripping force in closing adjustable
GFP2012NC-14	HSK-A63	460N - 1140N
GFP2012NC-25	VDI 40	460N - 1140N
GFP2012NC-34	Capto C4	460N - 1140N

Application example

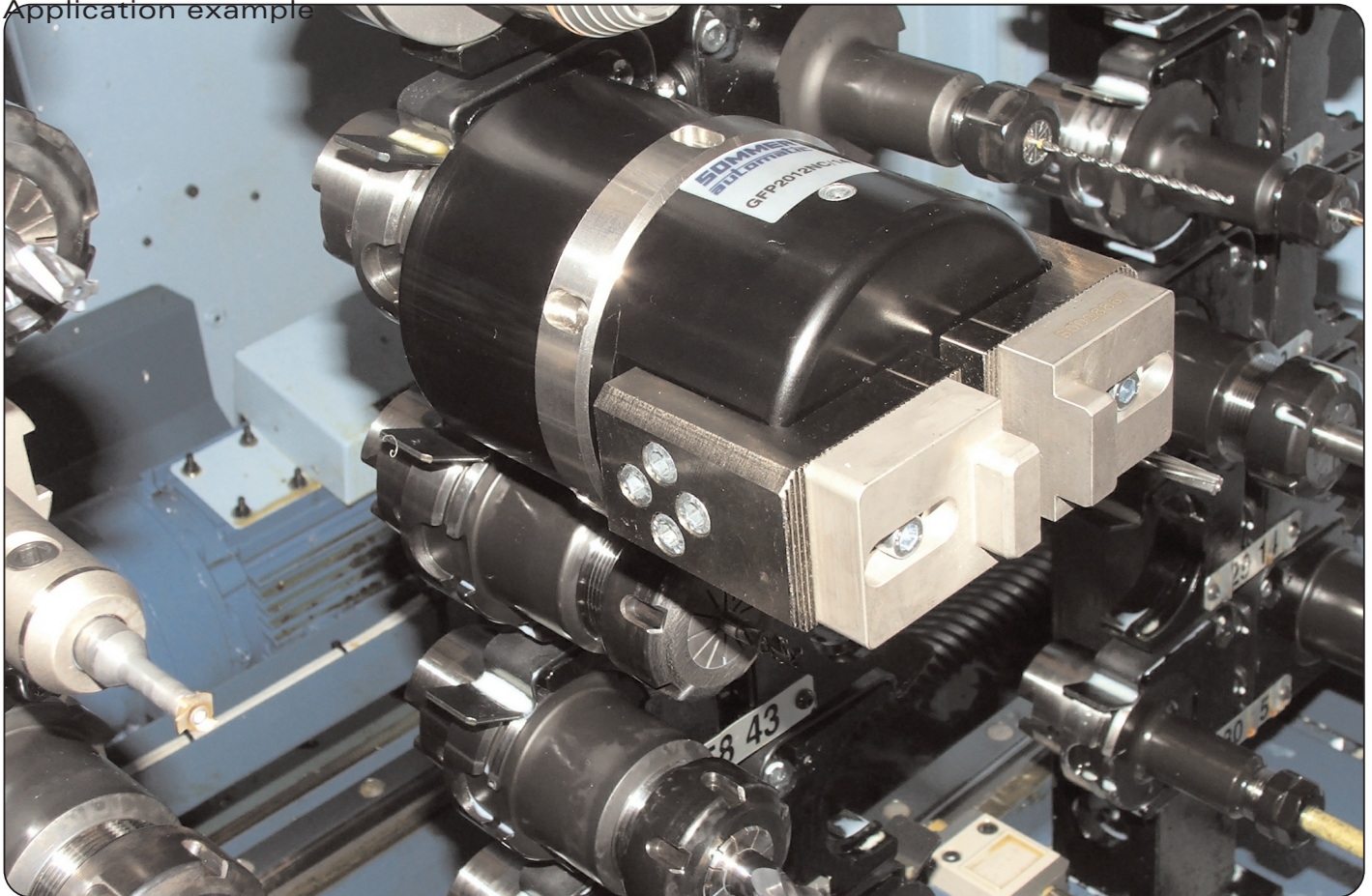

Parallel gripper with tool intake

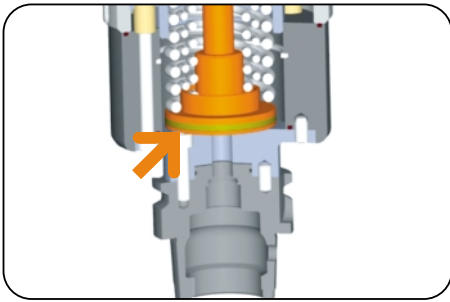

Drive

Single acting cylinder with spring return

- driven by tool machine cool lubrication supply
- closing movement carried out with three integrated springs



Guide

Sealed squer guide

- for high force and moment intake
- high precision due to low play guide
- sealed with additional wiper

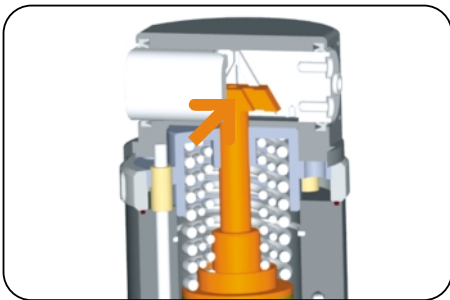

Power transfer

Positively driven wedge hook transmission

- optimum transmission of power to gripping force
- self-centering
- synchronization
- high repeatability

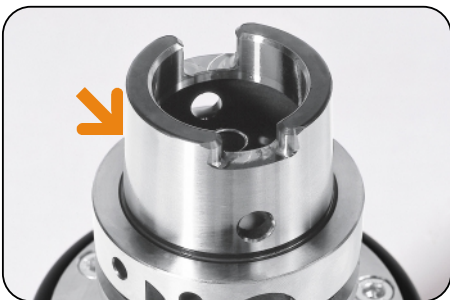

Machine connection

standardised tool intake

- HSK-A63
- VDI 40
- Capto C4
- Further tool intake on enquiry



Gripping jaw intake

Via centering sleeves

- precise positioning of individual gripping jaws
- quick, cost-effective and therefore economical jaw changing
- space-saving design



Gripping jaw

Standardised

- low construction effort
- cost-saving
- available as accessory

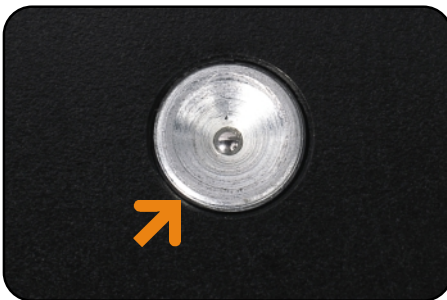

Maintenance

Regreasing of mechanics and guide on external Lubricating nipple

- service-friendly
- time saving
- standardised



Regulable gripping force

Spring force can be adjusted via adjustment ring

- protects workpiece
- flexibel
- infinitely adjustable from 460 N to 1140 N

Parallel gripper with tool intake



Gripping force diagram

Gripping force as a function of jaw length.

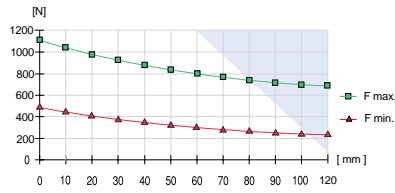

measured from top edge of housing

Forces and Moments

Max allowable forces and moments on jaws.

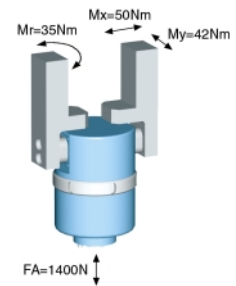

Gripping force diagram

Gripping force as a function of opening stroke

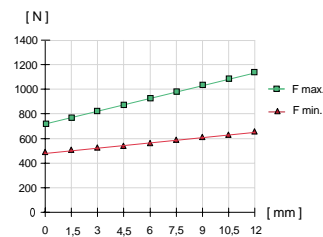

Included with purchase



Centring sleeve
Order no. BDST41000

Accessory list



Universal jaw
Order no. UB2012-01

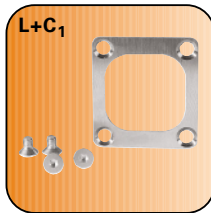

Cover sheet set
Order no. ADB2012



Hook key
Order no. ZUB0004

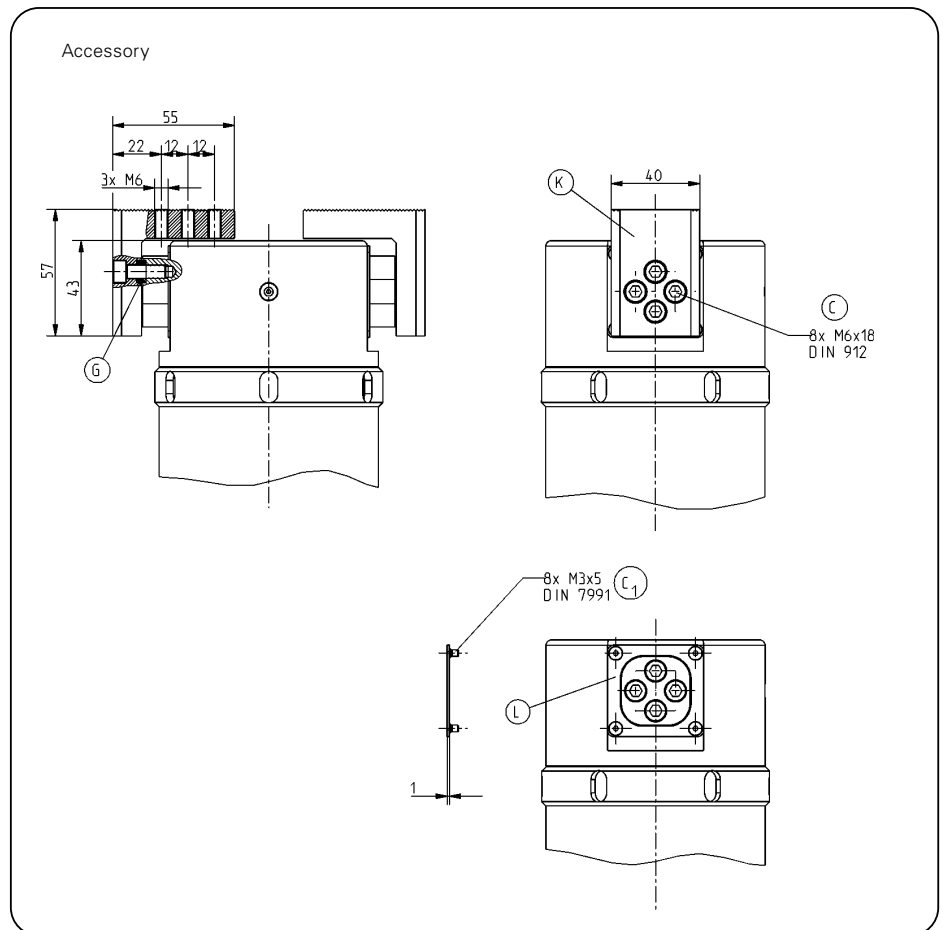

Subject to change without prior notice



Order no.:	GFP2012NC-14	GFP2012NC-25	GFP2012NC-34
Intake:	HSK-A63	VDI 40	Capto C4
Gripping force in closing min./max. [N]*:	460/1140	460/1140	460/1140
Closing time/opening time[s]:	depends on the pumpage of the tool machine		
Min./max. operating pressure [bar]:	20/50	20/50	20/50
Min./max. operating temperature [°C]:	5/80	5/80	5/80
Weight [kg]:	4,7	4,7	4,7

* adjustable, see gripping force diagramm

GFP2012NC-14

- ③ Connection for jaw
- ④ Lubrication nipple
- ②⑥ Connection for Coversheet set
- ②⑦ Tool Intake
- ②⑧ Adjustment ring

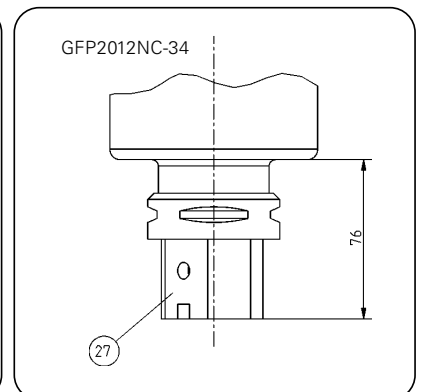
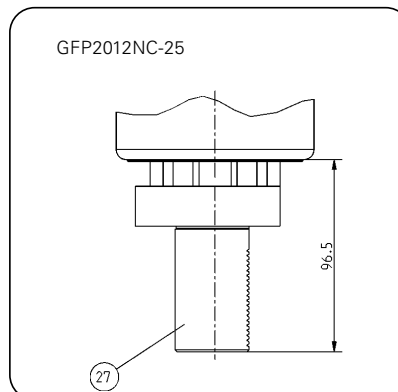
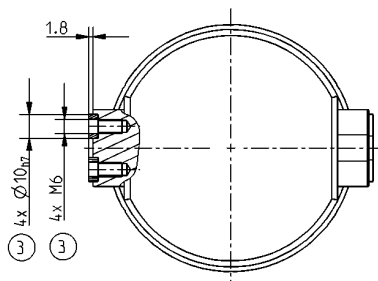
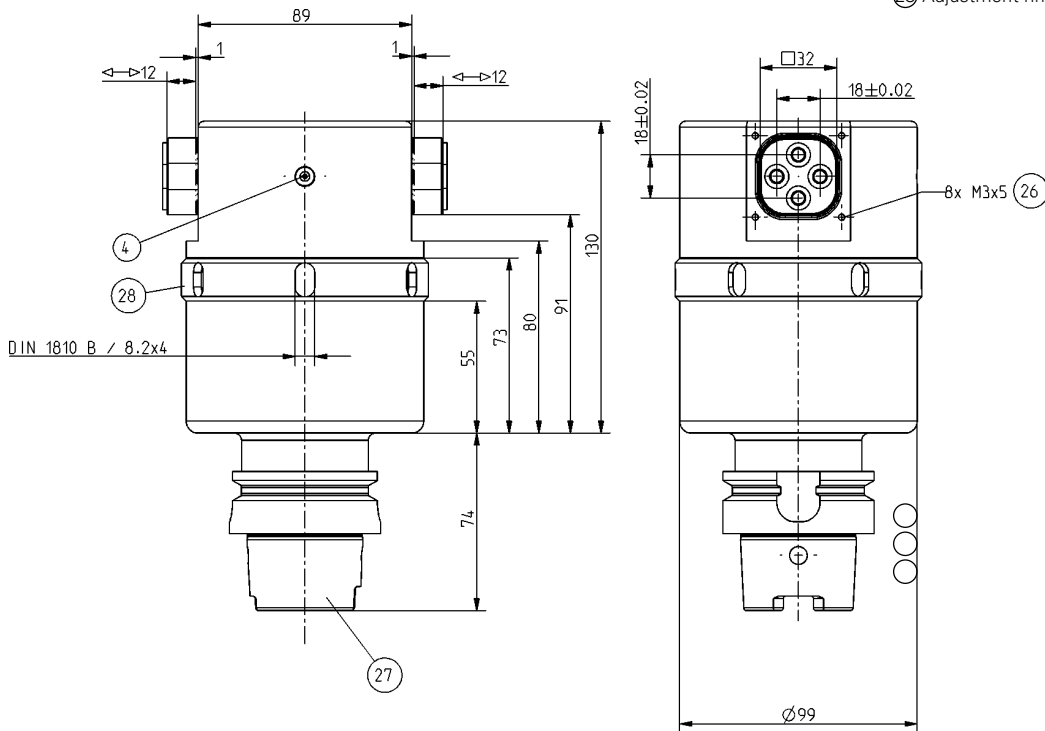

Subject to change without prior notice



➤ Grippers <i>pneumatic</i>	01
➤ Grippers <i>electrical</i>	02
➤ Grippers <i>hydraulic</i>	03
➤ Grippers <i>Special</i>	04
➤ Grip & Rotate Modules <i>pneumatic</i>	05
➤ Separators	06
➤ Swivel Units <i>pneumatic</i>	07
➤ Swivel Units <i>electrical</i>	08
➤ Swivel Units <i>hydraulic</i>	09
➤ Rotation Jaws <i>pneumatic</i>	10
➤ Axial Compensation Modules	11
➤ Tool Changers	12
➤ Robotics Accessories	13
➤ Linear Cylinders	14
➤ Shock Absorber	15
➤ Air Vane Motors	16
➤ Rotary Cylinders	17
➤ Vacuum Components	18