

## COMPONENTS

## MODULES

## ROBOTICS

## SYSTEMS

Linear Technology

Linearführungen

Racks and pinions

Zahnstangen und Ritzel

Bevel gears

Kegelräder

**Worm gear units: 07 – High Performance Servo Worm Gear Units**

**Schneckengetriebe: 07 – Hochleistungs-Servoschneckengetriebe**

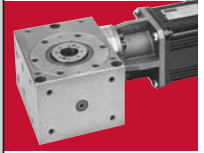
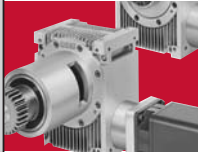
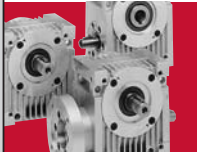
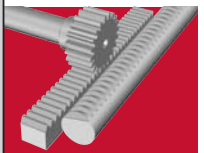
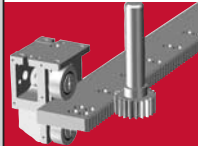
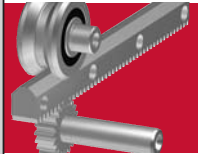

d,f,e/03.05/nr 0112129

Die Angaben in diesem Katalog wurden mit äusserster Sorgfalt erarbeitet und geprüft. Trotzdem kann für fehlerhafte oder unvollständige Angaben keine Haftung übernommen werden. Nachdruck, auch auszugsweise, ist nur mit unserer Genehmigung gestattet. Änderungen im Sinne technischer Verbesserungen bleiben vorbehalten.

Ce catalogue a été soigneusement composé et toutes ses données vérifiées. Toutefois, nous déclinons toute responsabilité en cas d'erreurs ou d'omissions. Par suite du développement constant de nos recherches, nous devons nous réserver tout droit de modifications de produits de notre fabrication.

This catalogue has been produced with a great deal of care and attention. All data has been checked for accuracy. However, no liability can be accepted for any incorrect or incomplete data. All rights reserved. Reproduction in whole or in part without our authorisation is prohibited.

**GÜDEL AG**

Industrie Nord  
CH-4900 Langenthal  
Switzerland  
phone +41 62 916 91 91  
fax +41 62 916 91 50  
eMail [info@ch.gudel.com](mailto:info@ch.gudel.com)  
[www.gudel.com](http://www.gudel.com)

**GÜDEL GmbH**

Carl-Benz-Strasse 5  
D-63674 Albstadt  
Germany  
phone +49 6047 9639 0  
fax +49 6047 9639 90  
eMail [info@de.gudel.com](mailto:info@de.gudel.com)  
[www.gudel.com](http://www.gudel.com)

**GÜDEL Inc.**

4881 Runway Blvd.  
US-Ann Arbor, MI 48108  
USA  
phone +1 734 214 0000  
fax +1 734 214 9000  
eMail [info@us.gudel.com](mailto:info@us.gudel.com)  
[www.gudel.com](http://www.gudel.com)

**ALL LOCAL REPRESENTATIONS SEE:**

**[WWW.GUDEL.COM/GOLOCAL](http://WWW.GUDEL.COM/GOLOCAL)**

## Einführung

Der vorliegende Katalog umfasst die Komponenten der Linear- und Antriebstechnik. Der Inhalt widerspiegelt die Erfahrung von mehr als 5 Jahrzehnten der Entwicklung und Fertigung von Längsführungen, Verzahnungen und Getriebebau.

Das nach ISO 9001: 2000 aufgebaute Qualitätssystem, eine grosse Lagerhaltung und ein weltweites Vertriebsnetz garantieren einen optimalen Kundennutzen.

Das umfangreiche Standardprogramm ermöglicht einen schnellen Zugriff auf alle Komponenten.

Ein erfahrenes Ingenieurteam hilft Ihnen bei der Auswahl, erarbeitet mit Ihnen Einbauvorschläge und optimiert Ihren Anwendungsfall. Auch Sonderteile nach Ihren Zeichnungen stellen wir gerne für Sie her.

Sprechen Sie mit uns!

## Introduction

Le catalogue suivant comprend les composants de la technique linéaire et d'entraînement. Le contenu reflète l'expérience de plus de 5 décennies de développement et de fabrication de guides longitudinaux, de dentures et de construction d'engrenages.

Le système de qualité élaboré selon ISO 9001: 2000, un stock important et un réseau de distribution mondial garantissent au client un profit optimal.

La riche gamme standard permet un accès rapide à tous les composants.

Une équipe d'ingénieurs expérimentés vous aidera à choisir, travaillera avec vous des projets de montage et optimisera votre cas d'application. Nous fabriquerons également des pièces spéciales pour vous selon vos dessins. Parlez-nous de vos applications!

## Introduction

This catalogue covers all the components of the linear and drive technology. Its content reflects the experience of more than 5 decades in the development and manufacture of linear guides, gears and gearboxes.

A quality system based on ISO 9001: 2000, a large inventory and a global distribution network guarantee optimal benefits to the customer.

The extensive standard programme makes rapid access to all components possible at all times.

An experienced engineering team will help you in your selection, and assist you in drawing up installation proposals and in the optimisation of your application. We will also be pleased to manufacture custom components to your own drawings. Call us!

## Qualitätskontrolle

Um die hohen Qualitätsanforderungen unserer Kundschaft zu erfüllen, werden die Module auf modernsten Werkzeugmaschinen in eigenen Werken gefertigt. Die Qualitätskontrolle geschieht gemäss ISO 9001 als Erststück- und Stichprobenkontrolle.

Dies garantiert unserer Kundschaft den Erwerb eines qualitativ hochwertigen Produktes.

## Production et qualité

Pour satisfaire les exigences de notre clientèle, les modules sont fabriqués dans nos propres usines par des machines modernes.

Le contrôle de qualité est fait suivant les exigences de la norme ISO 9001.

Tous ces efforts garantissent à notre clientèle un produit de haute qualité.

## Quality control

To meet the high requirements of our clients, the modules are manufactured in our factories by modern machine tools. Quality control is carried out in accordance with ISO 9001.

This guarantees our clients a continuous high product quality.



### The Swiss Association for Quality and Management Systems

SQS herewith certifies that the company named below has an appropriate management system which meets the requirements of the international standard for quality management and quality assurance (ISO 9001) and issues the company

## Güdel AG

CH-4900 Langenthal

the

### SQS Certificate ISO 9001:2000

on the basis of the audit result

Certified area

### Whole Company

CH-3052 Zollikofen, 1 January 2001

This SQS Certificate is valid up to and including 31 December 2003

Scope numbers 18, 29

Registration number 12585-03

Managing Director SQS

President SQS

T. Zahner

Prof. Dr. H. D. Seghezzi



8478 002-021



## Hochleistungs-Servogetriebe

Die AE-Baureihe kompakter Hochleistungs-Servoschneckengetriebe wird in 6 Baugrößen und Übersetzungen von 2:1 bis 24:1 hergestellt. Sie ist geeignet wo ein Höchstmaß an Dynamik und Zuverlässigkeit gefordert wird.

Die Exzenterflansche der Abtriebslagerung erlauben ein einfaches Ein- und Nachstellen des Verzahnungsspiels. Die Spezialkupplung an der Eintriebsseite und die Schrumpfscheibe an der Abtriebsseite gewährleisten einen spielfreien Kraftfluss.

Unsere Ingenieure, denen entsprechende Rechnungsprogramme zur Verfügung stehen, helfen Ihnen gerne Ihren Anwendungsfall zu optimieren.

## Servoréducteur à haute performance

La gamme des Servoréducteurs compacts de type AE est fabriquée en 6 tailles avec des rapports de réduction allant de 2:1 à 24:1. Ils sont recommandés où un grand rendement et une grande fiabilité sont nécessaires.

Les brides excentriques des paliers de sortie permettent de régler et de rattraper de manière simple le jeu entre la vis et la roue. L'accouplement au niveau de l'entrée moteur ainsi que la jonction de serrage au niveau de l'arbre de sortie permettent de garantir une transmission de puissance exempt de jeu.

De plus nos ingénieurs, à l'aide de programmes de calcul sont à votre disposition afin d'optimiser vos applications.

## High performance servo Gear Units

The AE-range of compact servo worm gear units are manufactured in 6 model sizes, with reductions from 2:1 to 24:1. They are suitable for use when a high efficiency and reliability are required.

The eccentric flanges of the hollow output shaft permit a simple setting and readjusting of the worm and wheel backlash. The drive coupling on the input shaft and a tension set on the hollow output shaft guarantee a power transmission torsion free and without backlash. Our engineers are equipped with calculation programs and will be glad to help you to find the right product for your application.



Bild 1

Bild 1  
Testing of gear boxes

# INHALTSVERZEICHNIS

## TABLE DES MATIÈRES / CONTENT

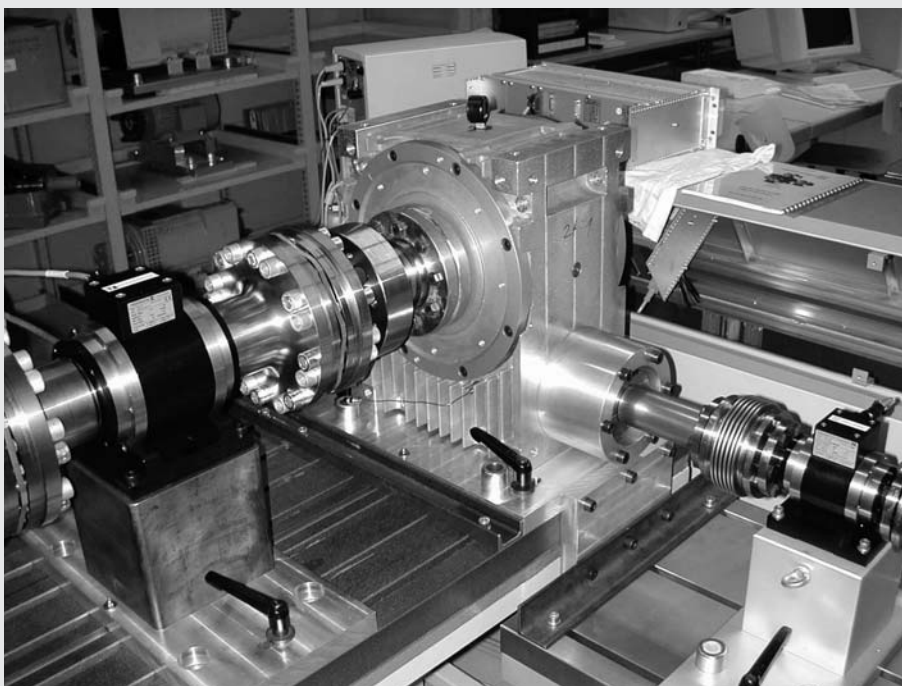
PRODUKTÜBERSICHT BAUKÄSTEN	Gamme de produits Le système modulaire	Product overview The modular system	07.02 07.03
AUSWAHLTABELLE	Sélection du Réducteur standard	Selection of standard worm gear unit	07.04
BAUGRÖSSEN 030	Tailles de fabrication 030	Sizes 030	07.06
BAUGRÖSSEN: 045	Taille de fabrication: 045	Size: 045	07.08
BAUGRÖSSEN: 060	Taille de fabrication: 060	Size: 060	07.10
BAUGRÖSSEN: 090	Taille de fabrication: 090	Size: 090	07.12
BAUGRÖSSEN: 120	Taille de fabrication: 120	Size: 120	07.14
BAUGRÖSSEN: 180	Taille de fabrication: 180	Size: 180	07.16
BERECHNUNGSBEISPIEL	Exemple de calcul	Calculation example	07.18
WARTUNG EINBAU- UND AUSBAU	Entretien Montage	Maintenance Assembly	07.19 07.20
MOTOREN APPLIKATIONEN	Applications des moteurs	Applications of motors	07.22
ANWENDUNGEN	Exemple d'application	Sample application	07.29

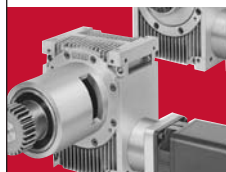

# PRODUKTÜBERSICHT

## GAMME DES PRODUITS PRODUCT OVERVIEW

### Hochleistungs-Schneckengetriebe

### Réducteurs à haute performance

### Worm gear unit

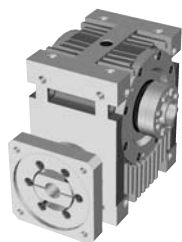

07.06-07.17

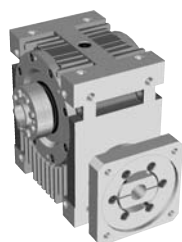

07.06-07.17

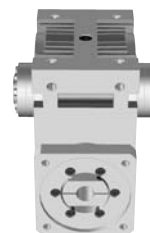

07.06-07.15



07.06-07.17

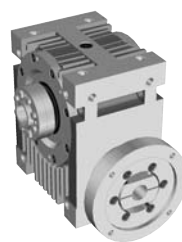

07.06-07.17



07.06-07.15

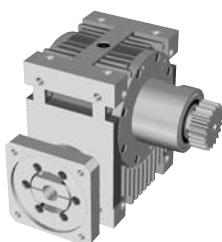

07.06-07.17

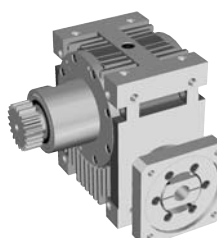

07.06-07.17

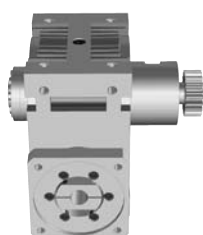

07.06-07.15

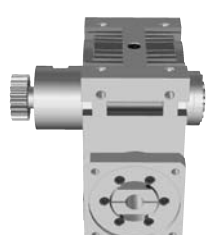

07.06-07.15

# BAUKASTEN

## LE SYSTÈME MODULAIRE THE MODULAR SYSTEM

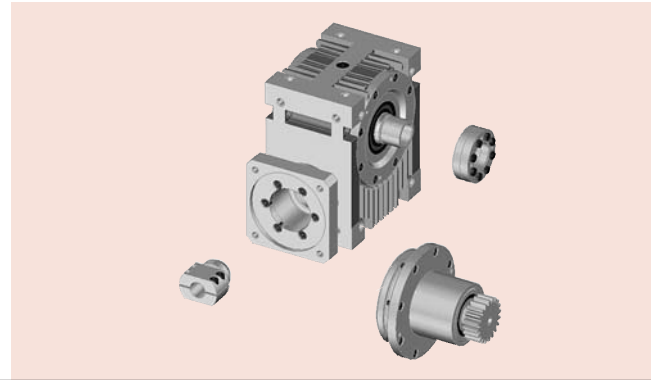

Die AE-Baureihe kompakter Hochleistungs-Servoschneckengetriebe werden in 5 Baugrößen und 10 Übersetzungen hergestellt. Die Baugröße ist identisch mit dem Achsabstand.

La gamme des servoréducteurs compacts de type AE est fabriquée suivant 5 tailles avec des rapports de réduction allant de 2:1 à 24:1. La taille correspond à l'entraxe du servoréducteur.

The AE-range of compact high performance gearboxes is available in 5 model sizes and 10 standard ratios. The gearbox size is identical to the centreline distance.

Baugrößen Taille Size	030		045		060		090		120		180	
Übersetzung Ratio	2:1	3:1	4:1	5:1	6:1	8:1	10:1	13 <sup>1</sup> / <sub>3</sub> :1	16:1	24:1		
Zahnspiel Jeu axial Backlash	3 – 6 Arc Min											

Das grosse Übersetzungsprogramm erlaubt eine optimale Abstimmung der Hochleistungs-Schneckengetriebe mit dem Servoantriebspaket. Die Zahnungen der Getriebe sind nach DIN 3975/76 ausgelegt und so optimiert, dass eine Spieleinstellung der Verzahnung über die Abtriebs-Exzenterflansche erfolgen kann. Die Gehäuse sind allseitig bearbeitet und haben Befestigungs- sowie Gewindebohrungen. Kühlrippen garantieren einen optimalen Abfluss der Wärme. Die synthetische Schmierung gewährleistet lange Lebensdauer sowie hohen Wirkungsgrad und grosse Laufruhe.

La grande variété de rapports de réductions permet d'obtenir un choix optimum avec un système asservis.

The large range of gearbox ratio's allows to match the exact requirement of the Servo Drive system.

Eine Spezialkupplung an der Eintriebsseite und eine Schrumpfscheibenkupplung an der Abtriebsseite garantieren einen spielfreien Kraftfluss und den Anbau eines beliebigen Motors. Die Auswahl- und Belastungstabellen sind auf Seite 07.04 für Getriebe und Seite 03.03 für Zahnstangen und Ritzel. Für Auslegungs- und Berechnungsbeispiele verweisen wir auf Seiten 07.16.

Les couples roues et vis et la denture sont réalisés selon la norme DIN 3975/76 et le rattrapage du jeu se fait avec les brides excentriques des paliers de sortie. Le carter est usiné sur tous les côtés et les trous de fixation permettent différentes positions de montage. La conception des ailettes permet d'obtenir une excellente dissipation thermique.

Worm and wormwheel are manufactured to DIN 3975/76 and the geometrical dimensions of the tooth is optimized so the backlash can be adjusted by using the eccentric hub of the output flanges.

La lubrification avec une huile synthétique garantit un grand rendement et un fonctionnement silencieux.

The casings are fully machined and with its many fixing bores and tapped holes allowing mounting in any positions. The integrated fins of the housing dissipate the heat and maintain an optimum running temperature.

L'accouplement de l'entrée moteur ainsi que la jonction de serrage ou niveau de l'arbre de sortie permettent une transmission de puissance exempt de jeu et le montage de tous types de moteurs.

The synthetic special oil for lubrication ensures a high degree of efficiency and smooth operation. A special clutch on the input and a discplate coupling on the output shaft guarantee largely torsion and backlash free connections and mounting of any type of motors.

Les tableaux de charge des réducteurs sont à la page 07.04 et pour les crémaillères, pignons page 03.03. Un exemple de calcul est présenté en page 07.16.

The selections- and load tables are on page 07.04 for gear boxes and on page 03.03 for racks and pinions.

Calculation example is on page 07.16.

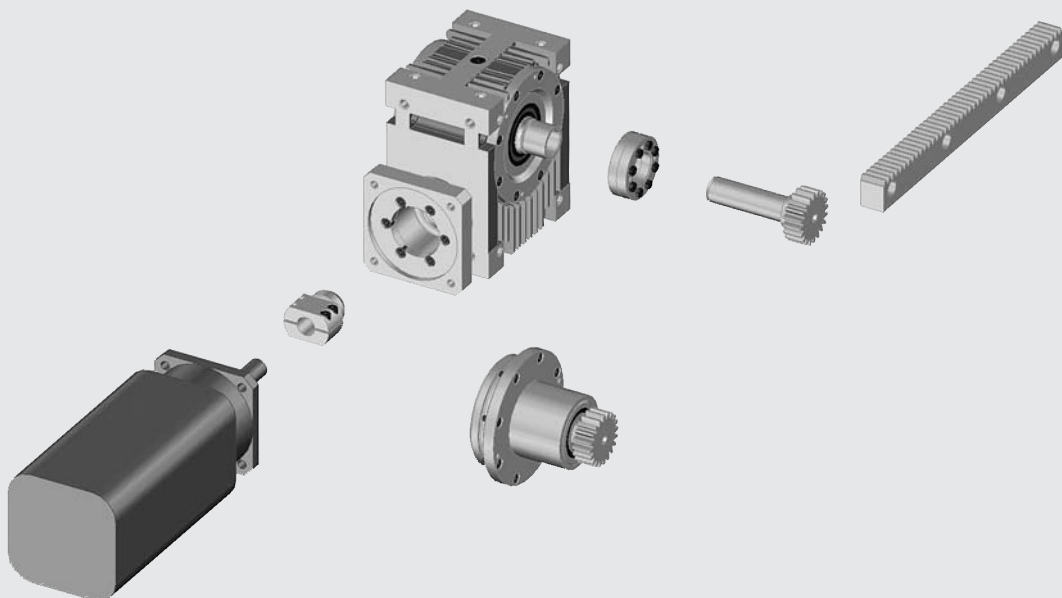



# WAHL DES SERVO SCHNECKENGETRIEBES

## SÉLECTION DU RÉDUCTEUR À HAUTE PERFORMANCE SELECTION OF WORM GEAR DRIVE UNIT

Die Getriebe sind für den Einsatz mit Dreh- und Gleichstrom-Servomotoren ausgelegt. Die Exzenterflansche der Abtriebslagerung erlauben ein einfaches Ein- und Nachstellen des Verzahnungsspiels.

Die Einheiten werden im Werk mit einem Verzahnungsspiel von  $< 6'$  eingestellt.

### Richtlinien für die Getriebewahl

Die in der Tabelle aufgeführten Abtriebsmomente  $T_{2N}$  (Nm) sind gültig für den Einsatz im stossfreien Servo-Betrieb bei  $20^{\circ}\text{C}$  Umgebungstemperatur. Bei höheren Belastungen sind die Tabellenwerte mit den nachstehenden Faktoren zu korrigieren.

Zusätzlich zu den erwähnten Betriebsfaktoren ist ein Sicherheitsfaktor einzurechnen, der Ihren Erfahrungen und den anwendungsspezifischen Sicherheitsanforderungen entspricht. Baugrößen 120 und 180: Bei Eintriebs-Drehzahlen über  $1500\text{ min}^{-1}$  und gleichzeitiger Einschaltdauer über 80%, bitten wir Sie mit Güdel Kontakt aufzunehmen.

Les réducteurs ont été développés pour être utilisés avec des moteurs d'asservissement. La bride excentrique du palier de sortie permet de régler et de rattraper de manière facile le jeu axial de la denture.

Sortie d'usine les réducteurs sont réglés avec un jeu de  $< 6'$ .

### Sélectionner un réducteur

Les couples indiqués dans le tableau,  $T_{2N}$  (Nm) sont valables pour des systèmes d'asservissement, fonctionnant sans chocs et à  $20^{\circ}\text{C}$  de température ambiante. Pour d'autres conditions les valeurs sont à corriger avec les coefficients selon tableaux.

Pour toutes applications particulières il est nécessaire de mettre un coefficient de sécurité supplémentaire aux coefficients déjà défini dans le tableau, celui-ci correspondant à chacune des applications client. Tailles 120 et 180: En cas de vitesse de rotation à l'entrée supérieure à  $1500\text{ min}^{-1}$  et un cycle de fonctionnement supérieur à 80% veuillez contacter Güdel s.v.p.

These high performance worm gearboxes were especially developed for use in high performance Servo-Driven Systems. The backlash is adjustable and is set by rotating the two eccentric flanges located on either side of the gearbox housing.

The units are set up in the factory with a backlash  $< 6'$ .

### Selecting a unit

The nominal torque  $T_{2N}$  (Nm) is valid for servo applications that run under normal shock free operations and at an ambient temperature of  $20^{\circ}\text{C}$ . Other conditions have to be corrected by factors shown below.

For specific applications it may be necessary to consider a safety factor, in addition to the factors already mentioned in the catalogue. This factor must be based on the customer's experience and any regulations specific to the application. Sizes 120 and 180: In the case of an input speed higher than  $1500\text{ min}^{-1}$  with a duty cycle higher than 80%, please contact Güdel.

$$T_{2N \text{ Mech.}} \geq T_2 \cdot f_b \cdot f_A$$

$$T_{2N \text{ Mech.}} \geq T_2 \cdot f_t \cdot f_{ED}$$

Beide Gleichungen müssen erfüllt sein / both required /

### Betriebsfaktor / Coefficient de marche / Service coefficient

Antrieb	Polynomia	Standard Servo / Sinus <sup>2</sup>	FU/VFD	AC-Motor	Exter
Output-shock					

$f_b$	1.0	1.1	1.25	1.4	1.6
-------	-----	-----	------	-----	-----

### Anlauffaktor / Coefficient de démarrage / Starting factor

Anlaufhäufigkeit / Fréquence de démarrage / Starting frequency	$\leq 60/\text{h}$	$\leq 360/\text{h}$	$\leq 1200/\text{h}$	$\leq 3600/\text{h}$
$f_A$	1.0	1.1	1.2	1.3

### Temperaturfaktor / Coefficient de température / Temperature factor

Umgebungstemperatur / Température ambiante / Ambient temperature	$\leq 10^{\circ}\text{C}$	$\leq 20^{\circ}\text{C}$	$\leq 30^{\circ}\text{C}$	$\leq 40^{\circ}\text{C}$	$\leq 50^{\circ}\text{C}$
$f_t$	0.85	1.0	1.2	1.5	1.9

### Einschaltdauerfaktor / Coefficient de service / Duty factor

Einschaltdauer / Cycle de service / Duty cycle	$\leq 25\%$	$\leq 40\%$	$\leq 60\%$	$\leq 70\%$	$\leq 100\%$
$f_{ED}$	0.7	0.9	1.1	1.2	1.4

$T_2$  (Nm): Drehmoment der Maschine / Couple de la machine / Required torque for driven machine

### Zulässige Belastungen auf die Abtriebswelle

Treten neben hohen Radialkräften gleichzeitig Axialkräfte auf, erbitten wir um Rückfrage. Die Abtriebsglocken mit der Ritzlagerung müssen konstruktiv abgestützt werden. Siehe Fig. ①.

### Charges admissibles au niveau de l'arbre de sortie

Si les charges radiales et axiales sont très importantes nous vous prions de nous consulter. Il est nécessaire de considérer dans la construction un support pour le palier du pignon de la bride de sortie voir Fig. ①.

### Permissible output shaft loads

In case of very high radial and axial loads please contact us. The output flange with the pinion bearing must be supported see Fig. ①.

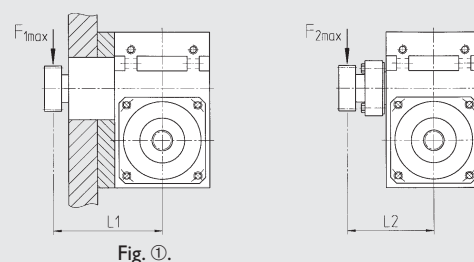
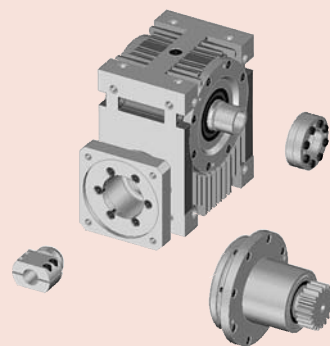

Fig. ①.

Typ	AE 030	AE 045	AE 060	AE 090	AE 120	AE 180
$L_1$ (mm)	78	104	126	165	268	340
$F_{1Max}$ (N)	1 400	3 000	4 500	9 750	24 000	60 000
$L_2$ (mm)	59	78	98	133	182	240
$F_{2Max}$ (N)	900	1 700	3 450	7 500	12 500	15 000

**Leistungstabellen**
**Tableau des caractéristiques**
**Efficiency tables**

Typ	i	T <sub>2max</sub>	n <sub>1</sub> (min <sup>-1</sup> )																				
			6000			4500			3000			1500			1000			500					
			P <sub>1</sub>	T <sub>2N</sub>	η	P <sub>1</sub>	T <sub>2N</sub>	η	P <sub>1</sub>	T <sub>2N</sub>	η	P <sub>1</sub>	T <sub>2N</sub>	η	P <sub>1</sub>	T <sub>2N</sub>	η	P <sub>1</sub>	T <sub>2N</sub>	η			
AE 030	2	35	1,97	4,9	0,79	1,72	5,9	0,81	1,39	7,4	0,84	0,91	10,0	0,86	0,68	11,3	0,86	0,40	12,9	0,85			
	3		2,05	7,8	0,79	1,76	9,2	0,82	1,40	11,2	0,84	0,88	14,4	0,86	0,65	16,0	0,86	0,37	17,9	0,84			
	4		1,89	9,4	0,78	1,61	11,0	0,81	1,25	13,3	0,83	0,77	16,7	0,85	0,56	18,3	0,85	0,32	20,1	0,83			
	5		1,54	9,4	0,77	1,33	11,0	0,78	1,02	13,1	0,81	0,62	16,2	0,83	0,44	17,5	0,83	0,25	19,2	0,81			
	6		1,20	8,6	0,75	1,02	9,9	0,76	0,79	11,7	0,77	0,47	14,3	0,80	0,34	15,5	0,81	0,18	16,9	0,80			
	8		1,10	10,1	0,72	0,94	11,6	0,73	0,72	13,7	0,74	0,42	16,6	0,77	0,30	17,9	0,77	0,17	19,4	0,76			
	10		0,88	9,5	0,68	0,74	10,9	0,69	0,57	12,8	0,71	0,33	15,4	0,73	0,24	16,6	0,74	0,13	17,9	0,74			
	13 1/3		0,72	9,4	0,62	0,59	10,8	0,65	0,44	12,6	0,67	0,26	15,1	0,68	0,19	16,2	0,68	0,10	17,5	0,67			
	16		0,74	10,5	0,56	0,59	12,0	0,60	0,44	14,0	0,62	0,26	16,9	0,64	0,18	18,1	0,65	0,10	19,5	0,63			
	24		0,57	10,3	0,47	0,45	11,8	0,51	0,34	13,7	0,53	0,20	16,4	0,54	0,14	17,6	0,55	0,08	19,0	0,54			
	AE 045		2	120	5,95	16,2	0,85	5,41	20,0	0,87	4,63	26,0	0,88	3,29	37,4	0,89	2,57	43,8	0,89	1,57	52,7	0,88	
3		6,34	26,0		0,86	5,69	31,6	0,87	4,76	40,3	0,89	3,25	55,4	0,89	2,48	63,3	0,89	1,47	73,9	0,88			
4		5,90	32,0		0,85	5,23	38,5	0,87	4,32	48,3	0,88	2,87	64,8	0,89	2,17	73,1	0,88	1,27	83,9	0,87			
5		4,88	32,4		0,84	4,28	38,7	0,85	3,48	48,1	0,87	2,27	63,4	0,88	1,70	71,0	0,87	0,98	80,5	0,86			
6		3,83	29,6		0,81	3,33	35,2	0,83	2,67	43,4	0,85	1,71	56,5	0,86	1,27	62,9	0,86	0,73	70,8	0,85			
8		3,53	35,2		0,79	3,04	41,6	0,81	2,42	51,0	0,83	1,55	65,8	0,84	1,14	72,9	0,84	0,65	81,7	0,82			
10		2,79	33,2		0,75	2,39	39,2	0,77	1,89	47,8	0,80	1,18	61,3	0,81	0,87	67,7	0,81	0,50	75,5	0,79			
13 1/3		2,22	33,0		0,70	1,88	38,8	0,73	1,48	47,2	0,75	0,92	60,3	0,77	0,68	66,4	0,77	0,39	73,9	0,75			
16		2,19	36,8		0,66	1,82	43,3	0,70	1,44	52,7	0,72	0,89	67,2	0,74	0,66	74,0	0,73	0,35	75,0	0,71			
24		1,63	36,1		0,58	1,35	42,5	0,62	1,06	51,6	0,64	0,65	65,6	0,66	0,48	72,2	0,65	0,27	77,9	0,63			
AE 060		2	300		12,65	35	0,88	11,73	44	0,89	10,35	59	0,90	7,75	89	0,90	6,23	107	0,90	3,96	135	0,89	
	3	13,65		58	0,88	12,52	71	0,89	10,82	93	0,90	7,79	135	0,91	6,11	158	0,90	3,75	192	0,89			
	4	12,78		71	0,88	11,61	88	0,89	9,89	113	0,90	6,94	159	0,90	5,38	184	0,90	3,24	219	0,88			
	5	10,56		73	0,87	9,51	89	0,88	8,01	113	0,89	5,51	157	0,89	4,23	180	0,89	2,52	211	0,88			
	6	8,24		67	0,85	7,36	81	0,87	6,13	103	0,88	4,15	140	0,89	3,16	160	0,88	1,87	186	0,87			
	8	7,56		80	0,83	6,72	96	0,84	5,56	121	0,86	3,74	164	0,86	2,83	186	0,86	1,67	215	0,84			
	10	5,93		75	0,80	5,24	91	0,82	4,30	114	0,83	2,86	153	0,84	2,16	173	0,84	1,27	199	0,82			
	13 1/3	4,69		75	0,75	4,11	90	0,78	3,34	113	0,80	2,20	151	0,81	1,66	170	0,81	0,98	195	0,78			
	16	4,54		84	0,72	3,97	101	0,75	3,23	126	0,77	2,13	168	0,78	1,61	190	0,77	0,86	195	0,74			
	24	3,37		82	0,64	2,91	99	0,67	2,34	124	0,69	1,53	165	0,70	1,16	185	0,70	0,66	202	0,67			
	AE 090	2		900				32,4	126	0,91	29,6	174	0,92	23,7	279	0,92	19,8	350	0,92	13,4	469	0,92	
3						35,3	206	0,92	31,7	279	0,92	24,4	432	0,93	19,9	528	0,92	12,9	679	0,92			
4						33,0	257	0,92	29,3	343	0,92	22,0	518	0,92	17,7	624	0,92	11,3	784	0,91			
5						27,2	262	0,91	23,9	348	0,92	17,6	516	0,92	14,0	615	0,92	8,8	761	0,91			
6						21,0	241	0,90	18,3	318	0,91	13,3	466	0,91	10,5	551	0,91	6,5	674	0,90			
8						19,2	288	0,88	16,6	377	0,89	12,0	547	0,90	9,4	644	0,89	5,8	782	0,88			
10						14,9	273	0,86	12,8	356	0,88	9,1	513	0,88	7,2	601	0,88	4,4	726	0,87			
13 1/3						11,5	272	0,83	9,8	354	0,85	7,0	507	0,85	5,5	592	0,85	3,3	712	0,84			
16						11,1	303	0,81	9,5	395	0,82	6,7	565	0,83	5,3	660	0,82	2,9	700	0,80			
24						7,9	298	0,74	6,7	388	0,76	4,7	553	0,77	3,7	645	0,76	2,1	727	0,74			
AE 120		2	2300					69,9	276	0,93	65,1	387	0,93	54,3	648	0,94	46,7	836	0,94	33,0	1177	0,93	
	3					76,9	457	0,93	70,5	631	0,94	56,9	1020	0,94	47,8	1284	0,94	32,4	1732	0,93			
	4					72,5	573	0,93	65,8	783	0,93	51,9	1237	0,94	42,9	1534	0,94	28,4	2018	0,93			
	5					59,8	588	0,93	53,9	798	0,93	41,8	1241	0,93	34,2	1523	0,93	22,3	1969	0,93			
	6					46,3	543	0,92	41,4	733	0,93	31,7	1126	0,93	25,8	1371	0,93	16,6	1752	0,92			
	8					42,2	650	0,91	37,6	873	0,91	28,5	1329	0,91	23,1	1609	0,91	14,7	2038	0,90			
	10					32,6	617	0,89	28,9	826	0,90	21,7	1248	0,90	17,5	1505	0,90	11,1	1895	0,89			
	13 1/3					25,1	616	0,87	22,1	822	0,88	16,5	1237	0,88	13,3	1487	0,88	8,4	1863	0,87			
	16					24,1	688	0,84	21,2	918	0,85	15,8	1380	0,86	12,7	1658	0,85	7,1	1824	0,84			
	24					16,9	677	0,79	14,8	903	0,80	11,0	1353	0,80	8,8	1622	0,80	5,3	1900	0,78			
	AE 180	6		8000							99,0	1798	0,95	80,6	2938	0,95	68,2	3726	0,95	46,7	5091	0,95	
8									89,8	2150	0,94	72,5	3486	0,94	61,0	4396	0,94	41,4	5950	0,94			
10									68,9	2041	0,93	55,2	3289	0,94	46,2	4131	0,94	31,2	5553	0,93			
13 1/3									52,5	2037	0,91	41,8	3268	0,92	34,9	4093	0,92	23,5	5473	0,92			
16									49,8	2277	0,90	39,7	3649	0,90	33,1	4566	0,90	22,2	6100	0,90			
24									34,2	2241	0,86	27,1	3583	0,87	22,6	4477	0,87	15,2	5963	0,86			

**i: Ab Lager / du stock / ex stock**

n <sub>1</sub>	(min <sup>-1</sup> )	:	Eintriebsdrehzahl / Vitesse d'entrée / input speed
T <sub>2Max</sub>	(Nm)	:	Max. Drehmoment bei Not – Aus / Couple max. en cas d'arrêt d'urgence / Max. torque in case of emergency stop.
T <sub>2N</sub>	(Nm)	:	Nenn Drehmoment am Abtrieb / Couple de sortie nominale / Nominal output torque
P <sub>1</sub>	(kW)	:	Eintriebsleistung / Puissance d'entrée / Input power
η		:	Wirkungsgrad / Rendement / Efficiency

# BAUGRÖSSE 030

TAILLE 030  
SIZE 030

Hochleistungs-Schneckengetriebe

Réducteur à haute performance

Worm gear unit

**a = 30 mm**

20 < L < 33

L ausgelegt für Flansch mit  $t_1 = 12\text{mm}$   
L sur la base d'une épaisseur de flange  $t_1 = 12\text{mm}$   
L based on a flange thickness  $t_1 = 12\text{mm}$



Pos. ⑤



Pos. ④

DIN 912 8.8

Fig. ②



Fig. ①

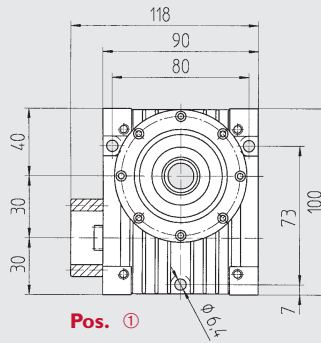

Pos. ①

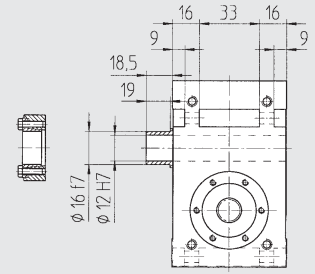

Pos. ⑥

AE 030/L

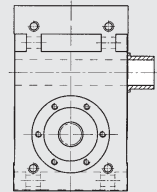
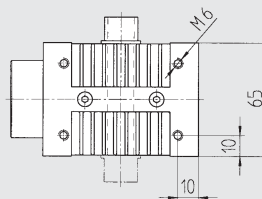

AE 030/R

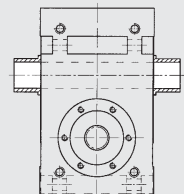

AE 030/S

Pos. ① Getriebe / Réducteur / Worm gear unit

Type	Part No.	Ratio	Inertia	
L		i	$J_{red}$ ( $10^{-7}$ kg m <sup>2</sup> )	m (kg)
AE 030/L	403 000	2 : 1	138	1.6
AE 030/R	403 008	3 : 1	69	
AE 030/S	403 009	4 : 1	45	
		5 : 1	34	
		6 : 1	28	
		8 : 1	22	
		10 : 1	19	
		13½ : 1	17	
		16 : 1	16	
		24 : 1	15	

i: ab Lager / sur stock / from stock

Pos. ④ Flansch / Bride / Flange

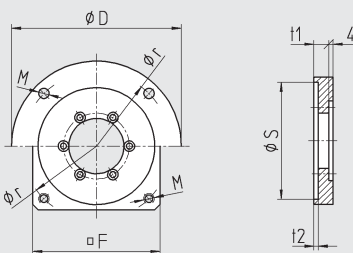

Part No.	Fig.	S	r	F	t <sub>1</sub>	t <sub>2</sub>	D	M	m (kg)
403 083	①	40	63	55	12	4	—	M4	0.2
403 090	①	50	70	60	12	4	—	M5	
403 081	①	50	95	82	12	4	—	M6	
403 082	①	60	75	70	12	4	—	M5	
403 091	①	60	90	75	12	4	—	M5	
403 086	①	70	85	80	12	4	—	M6	
403 092	①	70	90	80	12	4	—	M6	
403 080	①	80	100	92	12	4	—	M6	
403 087	①	80	100	90	21	8	—	M6	0.3
403 085	②	60	75	—	12	4	90	5.8	
403 084	②	70	85	—	12	4	105	7	

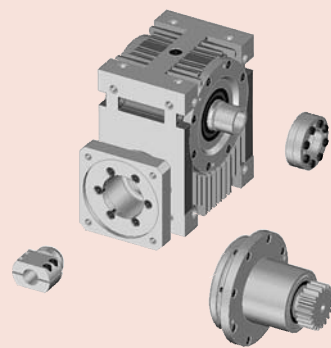

**Pos. ⑤ Kupplung / Accouplement / Coupling**

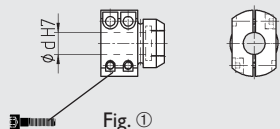

Part No.	Fig.	Inertia					
		d	J (10 <sup>-6</sup> kg m <sup>2</sup> )	T <sub>1max</sub> (Nm)		MA (Nm)	m (kg)
403 023	①	8	11.5	3.4	M3x16	1.37	0.1
403 022	①	9	11.5	3.8	M3x16		
403 025	①	10	11.0	4.0	M3x16		
403 021	①	11	11.0	4.7	M3x16		
403 020	①	14	11.0	6.0	M3x16		

T<sub>1max</sub>: maximal übertragbares Moment der Kupplung / Couple max. de l'accouplement / Maximum torque of coupling

MA: Anziedrehmoment / Couple de serrage / Tightening torque

**Pos. ⑥ Schrumpfscheiben-Kupplung / Jonction arbre-moyeu / Tension set**

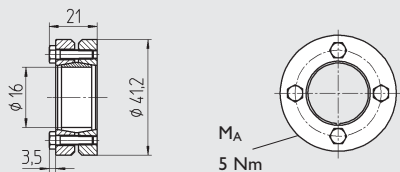

Part No.	Inertia		
	J (10 <sup>-6</sup> kg m <sup>2</sup> )	T <sub>2max</sub> (Nm)	m (kg)
403 031	36	67	0.12

T<sub>2max</sub>: maximal übertragbares Moment der Kupplung / Couple max. de l'accouplement / Maximum torque of coupling

J<sub>red</sub> = J / i<sup>2</sup>

**Zubehör**

**Accessoires**

**Accessories**

**Pos. ② Abtrieb mit Ritzel / Bride de sortie avec pignon / Output flange with pinion**

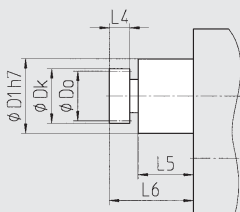

Part No.	Module	p	z	D <sub>0</sub>	D <sub>k</sub>	D <sub>1</sub>	L <sub>4</sub>	L <sub>5</sub>	L <sub>6</sub>	J	m (kg)
403 050	0.6366	2.0	30	19.10	20.4	47	9.5	38	50	38	0.35
403 052	1.0	3.142	25	25	27	47	9.5	38	50	40	0.4

p (mm): Teilung / pas / pitch      J (10<sup>-6</sup> kg m<sup>2</sup>): Inertia      J<sub>red</sub> = J / i<sup>2</sup>

**Pos. ③ Distanzstücke / Entretoise / Spacer**

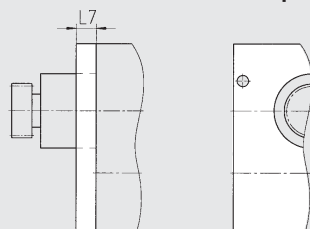

Part No.	Mat.	L <sub>7</sub>	m (kg)
403 060	Alu	19	0.2

**Bestellbeispiel**

**Exemple de commande**

**Ordering example**

Pos. ① AE 030/L:  i:

Pos. ④

Pos. ⑤

Pos. ⑥

Zubehör

Pos. ②

Pos. ③

Angaben für speziellen Flansch und Kupplung  
 Spécification pour la bride de sortie et l'accouplement spéciale  
 Specification for special flange and coupling

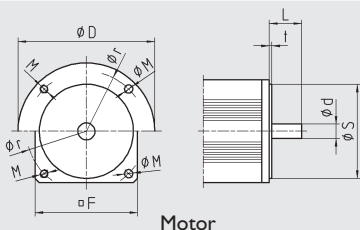

d :  [mm]      ØM :  [mm]

L :  [mm]      M : alternativ  M... [mm]

S :  [mm]      t :  [mm]

r :  [mm]

□ F :  [mm]

○ D : alternativ  [mm]

# BAUGRÖSSE 045

TAILLE 045  
SIZE 045

Hochleistungs-Schneckengetriebe

Réducteur à haute performance

Worm gear unit

## a = 45 mm

$33 \leq L_2 < 43$

$20 < L_1 < 33$

L ausgelegt für Flansch mit  $t_1 = 14\text{mm}$

L sur la base d'une épaisseur de flange  $t_1 = 14\text{mm}$

L based on a flange thickness  $t_1 = 14\text{mm}$

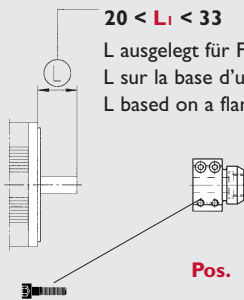

DIN 912 8.8

Pos. ⑤

Pos. ④

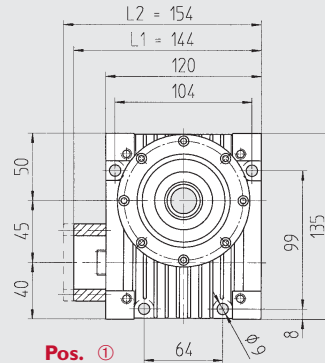

Pos. ①

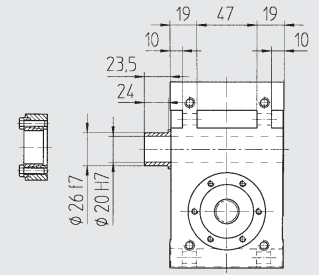

Pos. ⑥

AE 045/L

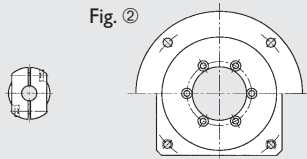
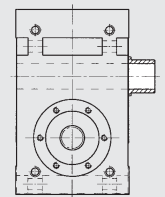
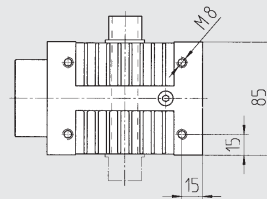
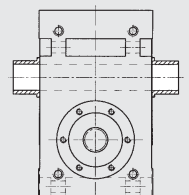

Fig. ②

Fig. ①



AE 045/R



AE 045/S

Pos. ① Getriebe / Réducteur / Worm gear unit

Type	Part No.		Ratio	Inertia	
	$L_1$	$L_2$	i	$J_{red}$ ( $10^{-6}$ kg m <sup>2</sup> )	m (kg)
AE 045/L	404 500	404 510	2 : 1	97	3,5
AE 045/R	404 508	404 518	3 : 1	47	
AE 045/S	404 509	404 519	4 : 1	29	
			5 : 1	21	
			6 : 1	16	
			8 : 1	12	
			10 : 1	10	
			13½ : 1	8	
			16 : 1	7	
			24 : 1	6	

i: ab Lager / sur stock / from stock

Pos. ④ Flansch / Bride / Flange

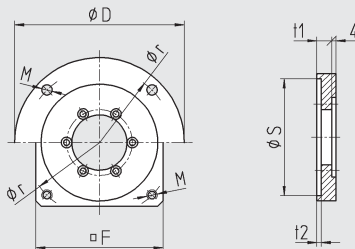

Part No.	Fig.	S	r	F	t <sub>1</sub>	t <sub>2</sub>	D	M	m (kg)
404 590	①	50	70	70	14	4	—	M5	0.25
404 581	①	50	95	82	14	4	—	M6	
404 582	①	60	75	70	14	4	—	M5	
404 592	①	60	90	75	14	4	—	M5	
404 585	①	70	85	80	14	4	—	M6	
404 593	①	70	90	80	14	4	—	M6	
404 580	①	80	100	92	14	4	—	M6	
404 594	①	80	100	90	18	8	—	M6	
404 583	①	95	115	100	14	4	—	M8	
404 595	①	110	145	120	14	4	—	M8	0.3
404 587	①	95	115	105	23	11	—	M8	
404 584	②	70	85	—	14	4	105	ø7	
404 586	②	80	100	—	14	4	120	ø7	

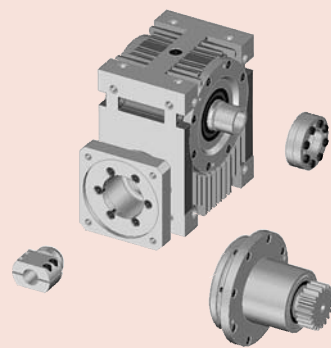

**Pos. ⑤ Kupplung / Accouplement / Coupling**

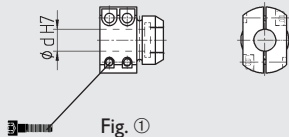

Part No.	Fig.	Inertia					
		d	J (10 <sup>-6</sup> kg m <sup>2</sup> )	T <sub>1max</sub> (Nm)		M <sub>A</sub> (Nm)	m (kg)
404 523	①	9	28	6.7	M4x16	3.1	0.15
404 522	①	11	27	8.2	M4x16		
404 521	①	14	26	10.4	M4x16		
404 525	①	16	26	12.0	M4x16		
404 520	①	19	25	14.2	M4x16		

T<sub>1max</sub>: maximal übertragbares Moment der Kupplung / Couple max. de l'accouplement / Maximum torque of coupling

M<sub>A</sub>: Anziehdrehmoment / Couple de serrage / Tightening torque

**Pos. ⑥ Schrumpfscheiben-Kupplung / Jonction arbre-moyeu / Tension set**

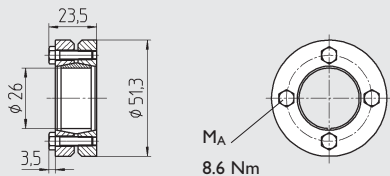

Part No.	Inertia		
	J (10 <sup>-6</sup> kg m <sup>2</sup> )	T <sub>2max</sub> (Nm)	m (kg)
404 531	90	142	0.2

T<sub>2max</sub>: maximal übertragbares Moment der Kupplung / Couple max. de l'accouplement / Maximum torque of coupling

$J_{red} = J / i^2$

**Zubehör**

**Accessoires**

**Accessories**

**Pos. ② Abtrieb mit Ritzel / Bride de sortie avec pignon / Output flange with pinion**

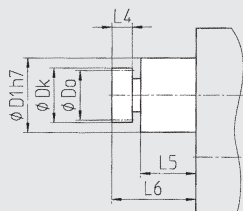

Part No.	Module	p	z	D <sub>0</sub>	D <sub>k</sub>	D <sub>1</sub>	L <sub>4</sub>	L <sub>5</sub>	L <sub>6</sub>	J	m (kg)
404 550	1.5915	5.0	20	31.83	35	60	11.5	43	59	109	1.7
404 551	1.5915	5.0	20	31.83	35	60	14.5	43	69	111	1.7

p (mm): Teilung / pas / pitch      J (10<sup>-6</sup> kg m<sup>2</sup>): Inertia       $J_{red} = J / i^2$

**Pos. ③ Distanzstücke / Entretoise / Spacer**

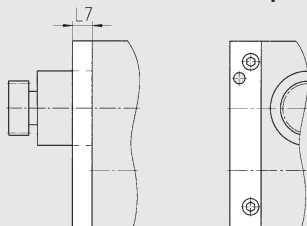

Part No.	Mat.	L <sub>7</sub>	m (kg)
404 560 ①	Alu	19	0.25

① Lieferung paarweise / Livraison par paire / Delivery in pairs only

**Bestellbeispiel**

**Exemple de commande**

**Ordering example**

Pos. ①	AE 045/L:	404 510	i:	5:1
Pos. ④		404 581		
Pos. ⑤		404 521		
Pos. ⑥		404 530		

Zubehör	
Pos. ②	<input type="text"/>
Pos. ③	<input type="text"/>

Angaben für speziellen Flansch und Kupplung  
 Spécification pour la bride de sortie et l'accouplement spéciale  
 Specification for special flange and coupling

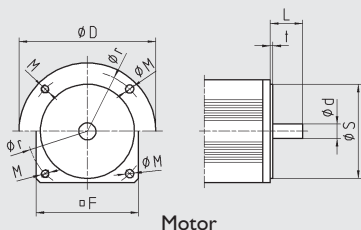

d :	<input type="text"/>	[mm]	ØM :	<input type="text"/>	[mm]
L :	<input type="text"/>	[mm]	M :	alternativ <input type="text"/>	[mm]
S :	<input type="text"/>	[mm]	t :	<input type="text"/>	[mm]
r :	<input type="text"/>	[mm]			
□ F :	<input type="text"/>	[mm]			
○ D :	alternativ <input type="text"/>	[mm]			

# BAUGRÖSSE 060

TAILLE 060  
SIZE 060

Hochleistungs-Schneckengetriebe

Réducteur à haute performance

Worm gear unit

**a = 60 mm**

$50 \leq L_3 < 65$

$40 \leq L_2 < 50$

$25 < L_1 < 40$

L ausgelegt für Flansch mit  $t_1 = 14\text{mm}$

L sur la base d'une épaisseur de flange  $t_1 = 14\text{mm}$

L based on a flange thickness  $t_1 = 14\text{mm}$

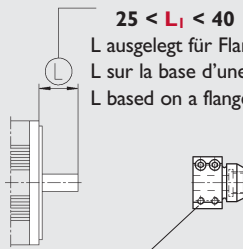

Pos. ⑤

Pos. ④

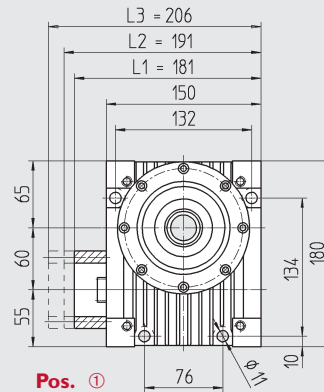

Pos. ①

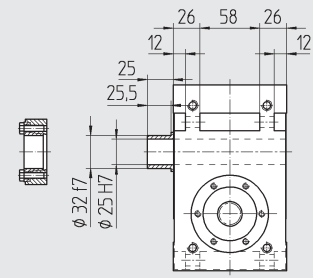

Pos. ⑥

AE 060/L

DIN 912 8.8

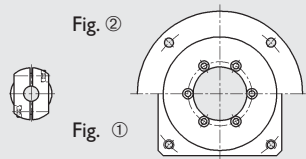
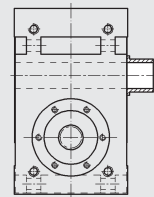
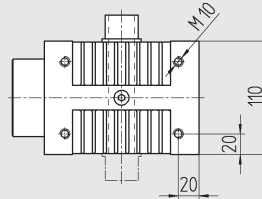
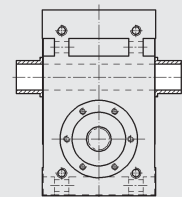

Fig. ②

Fig. ①



AE 060/R



AE 060/S

Pos. ① Getriebe / Réducteur / Worm gear unit

Type	Part No.			Ratio	Inertia		
	$L_1$	$L_2$	$L_3$	i	$J_{red}$ ( $10^{-6}$ kg m <sup>2</sup> )	m (kg)	
AE 060/L	406 000	406 010	406 015	2 : 1	416	7.7	
AE 060/R	406 008	406 018	406 016	3 : 1	199		
AE 060/S	406 009	406 019	406 017	4 : 1	122		
				5 : 1	87		
				6 : 1	67		
				8 : 1	49		
				10 : 1	40		
				13½ : 1	33		
				16 : 1	30		
				24 : 1	27		

i: ab Lager / sur stock / from stock

Pos. ④ Flansch / Bride / Flange

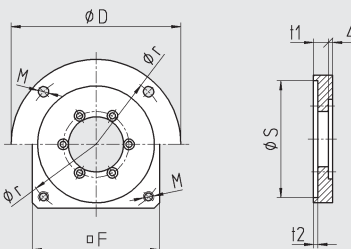

Part No.	Fig.	S	r	F	$t_1$	$t_2$	D	M	m (kg)
406 085	①	80.0	100	92	14	5	—	M6	0.5
406 090	①	95.0	115	100	14	5	—	M6	
406 084	①	95.0	115	105	14	5	—	M8	
406 083	①	95.0	130	115	14	5	—	M8	
406 082	①	95.0	165	140	14	5	—	M10	
406 089	①	110.0	130	116	14	5	—	M8	
406 091	①	110.0	145	120	14	5	—	M8	
406 092	①	110.0	145	130	20	11	—	M8	
406 093	①	130.0	165	142	20	11	—	M10	
406 081	①	110.0	165	140	14	5	—	M10	
406 080	①	130.0	165	140	14	5	—	M10	
406 086	②	110.0	130	—	14	5	160	ø9	
406 088	②	130.0	165	—	14	5	185	M10	



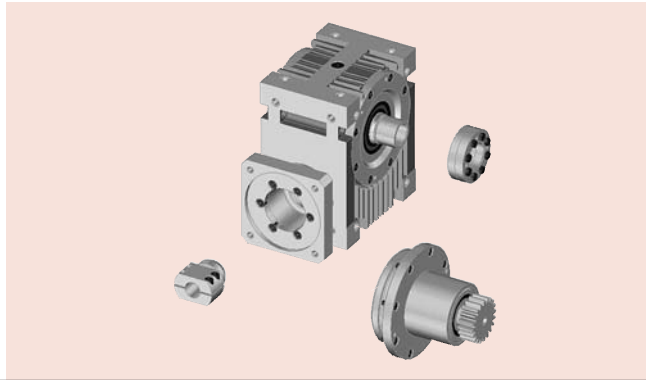

**Pos. ⑤ Kupplung / Accouplement / Coupling**

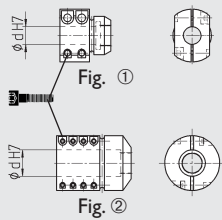

Part No.	Fig.	Inertia					
		d	J (10 <sup>-6</sup> kg m <sup>2</sup> )	T <sub>1max</sub> (Nm)		M <sub>A</sub> (Nm)	m (kg)
406 021	①	19	83	32.8	M6x20	10.5	0.3
406 024	①	22	80	38.0	M6x20		
406 020	①	24	79	41.5	M6x20		
406 026	②	28	294	41.9	M4x16	3.12	0.45
406 023	②	32	271	47.9	M4x16		

T<sub>1max</sub>: maximal übertragbares Moment der Kupplung / Couple max. de l'accouplement / Maximum torque of coupling

M<sub>A</sub>: Anziehdrehmoment / Couple de serrage / Tightening torque

Fig. ② nur mit L3 einsetzbar / Fig. ② impose longueur L3 / Fig. ② requires length L3.

**Pos. ⑥ Schrumpfscheiben-Kupplung / Jonction arbre-moyeu / Tension set**

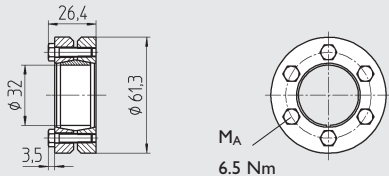

Part No.	Inertia		
	J (10 <sup>-6</sup> kg m <sup>2</sup> )	T <sub>2max</sub> (Nm)	m (kg)
406 031	200	300	0.3

T<sub>2max</sub>: maximal übertragbares Moment der Kupplung / Couple max. de l'accouplement / Maximum torque of coupling

$J_{red} = J / i^2$

**Zubehör**

**Accessoires**

**Accessories**

**Pos. ② Abtrieb mit Ritzel / Bride de sortie avec pignon / Output flange with pinion**

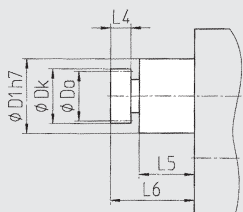

Part No.	Module	p	z	D <sub>0</sub>	D <sub>k</sub>	D <sub>1</sub>	L <sub>4</sub>	L <sub>5</sub>	L <sub>6</sub>	J	m (kg)
406 050	2.381	7.5	20	47.75	52.5	72	19.5	53	80.5	307	1.6
406 052	3.1831	10.0	14	46.47	52.5	72	29.5	58	100	338	2.6
406 051	3.1831	10.0	20	63.66	70.0	72	29.5	58	100	620	3.0

p (mm): Teilung / pas / pitch      J (10<sup>-6</sup> kg m<sup>2</sup>): Inertia      J<sub>red</sub> = J / i<sup>2</sup>

**Pos. ③ Distanzstücke / Entretoise / Spacer**

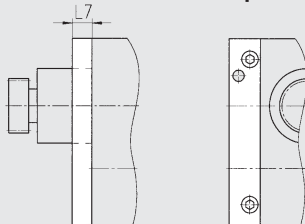

Part No.	Mat.	L <sub>7</sub>	m (kg)
406 060 ①	Alu	19	0.25
406 061 ①	Alu	22	0.28

① Lieferung paarweise / Livraison par paire / Delivery in pairs only

**Bestellbeispiel**

**Exemple de commande**

**Ordering example**

Pos. ① AE 060/L:  i:

Pos. ④

Pos. ⑤

Pos. ⑥

Zubehör

Pos. ②

Pos. ③

Angaben für speziellen Flansch und Kupplung  
 Spécification pour la bride de sortie et l'accouplement spéciale  
 Specification for special flange and coupling

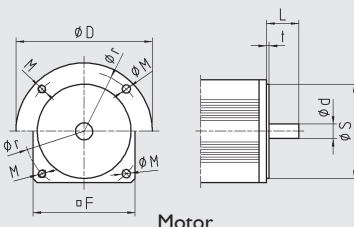

d :  [mm]      ØM :  [mm]

L :  [mm]      M : alternativ  [mm]

S :  [mm]      t :  [mm]

r :  [mm]

□ F :  [mm]

○ D : alternativ  [mm]



# BAUGRÖSSE 090

TAILLE 090  
SIZE 090

Hochleistungs-Schneckengetriebe

Réducteur à haute performance

Worm gear unit

**a = 90 mm**

$62 \leq L_2 < 82$

$40 < L_1 < 62$

L ausgelegt für Flansch mit  $t_1 = 18\text{mm}$

L sur la base d'une épaisseur de flange  $t_1 = 18\text{mm}$

L based on a flange thickness  $t_1 = 18\text{mm}$

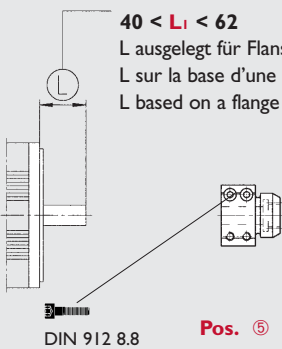

Pos. ⑤



Pos. ④

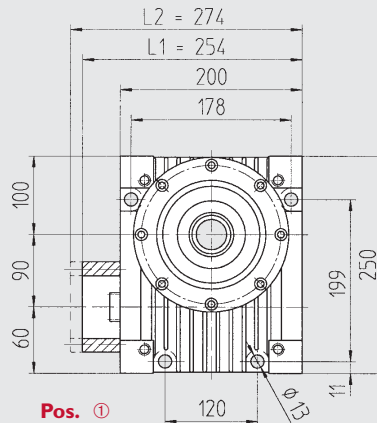

Pos. ①

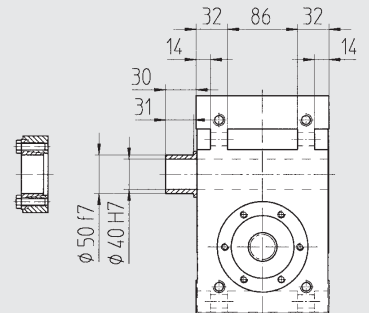

Pos. ⑥

AE 090/L

Fig. ②



Fig. ①

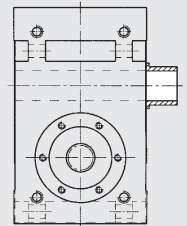
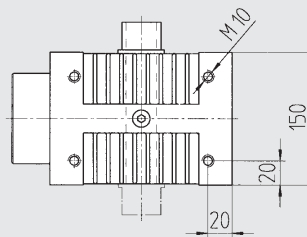
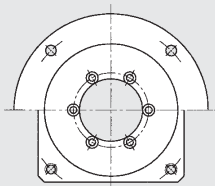

AE 090/R

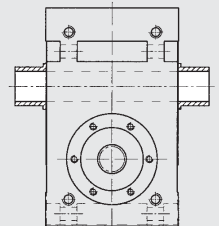

AE 090/S

**Pos. ① Getriebe / Réducteur / Worm gear unit**

Type	Part No.		Ratio	Inertia	
	$L_1$	$L_2$	$i$	$J_{red}$ ( $10^{-5}$ kg m <sup>2</sup> )	$m$ (kg)
AE 090/L	409 000	409 010	2 : 1	308	21.0
AE 090/R	409 008	409 018	3 : 1	147	
AE 090/S	409 009	409 019	4 : 1	91	
			5 : 1	65	
			6 : 1	51	
			8 : 1	37	
			10 : 1	30	
			13 1/3 : 1	25	
			16 : 1	23	
			24 : 1	21	

i: ab Lager / sur stock / from stock

**Pos. ④ Flansch / Bride / Flange**

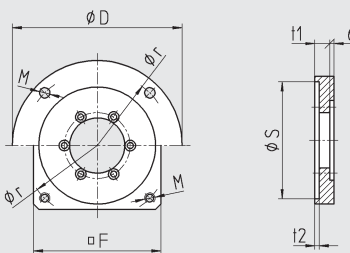

Part No.	Fig.	S	r	F	t <sub>1</sub>	t <sub>2</sub>	D	M	m (kg)
409 090	①	95.0	115	105	18	6	—	M6	1.0
409 085	①	95.0	115	105	18	6	—	M8	
409 084	①	95.0	130	115	18	6	—	M8	
409 089	①	110.0	130	116	18	6	—	M8	
409 091	①	110.0	145	130	27	11	—	M8	
409 083	①	110.0	165	140	18	6	—	M10	
409 092	①	114.3	200	174	18	6	—	M12	
409 082	①	130.0	165	142	18	6	—	M10	
409 094	①	130.0	165	142	24	12	—	M10	
409 080	①	130.0	215	193	18	6	—	M12	
409 081	①	180.0	215	190	18	6	—	M12	
409 093	①	200.0	235	220	18	6	—	M12	
409 086	②	130.0	165	—	18	6	200	ø11	
409 087	②	180.0	215	—	18	6	250	ø14	
409 088	②	230.0	265	—	18	6	300	ø14	

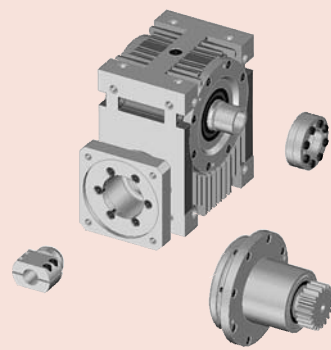

**Pos. ⑤ Kupplung / Accouplement / Coupling**

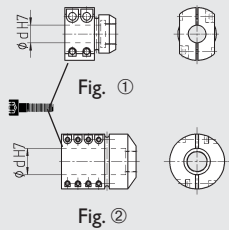

Part No.	Fig.	d	Inertia			M <sub>A</sub> (Nm)	m (kg)
			J (10 <sup>-6</sup> kg m <sup>2</sup> )	T <sub>1max</sub> (Nm)	Module		
409 023	①	19	469	64	M8x30	26.0	0.8
409 022	①	24	463	74	M8x30		
409 021	①	28	454	86	M8x30		
409 020	①	32	442	98	M8x30		
409 028	①	35	420	107	M8x30		
409 024	②	38	1162	131	M6x20	10.5	0.9
409 025	②	42	1096	145	M6x20		

T<sub>1max</sub>: maximal übertragbares Moment der Kupplung / Couple max. de l'accouplement / Maximum torque of coupling / **MA**: Anziehdrehmoment / Couple de serrage / Tightening torque  
 Fig. ② nur mit L2 einsetzbar / Fig. ② impose longueur L2 / Fig. ② requires length L2.

**Pos. ⑥ Schrumpfscheiben-Kupplung / Jonction arbre-moyeu / Tension set**

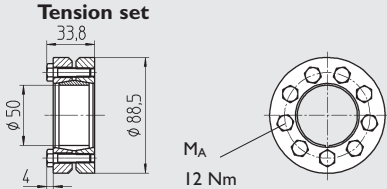

Part No.	Inertia		
	J (10 <sup>-6</sup> kg m <sup>2</sup> )	T <sub>2max</sub> (Nm)	m (kg)
409 031	1150	1250	0.86

T<sub>2max</sub>: maximal übertragbares Moment der Kupplung / Couple max. de l'accouplement / Maximum torque of coupling  
 $J_{red} = J / i^2$

**Zubehör**

**Accessoires**

**Accessories**

**Pos. ② Abtrieb mit Ritzel / Bride de sortie avec pignon / Output flange with pinion**

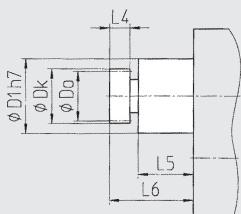

Part No.	Module	p	z	D <sub>0</sub>	D <sub>k</sub>	D <sub>1</sub>	L <sub>4</sub>	L <sub>5</sub>	L <sub>6</sub>	J	m (kg)
409 050	3.183	10	20	63.66	70	98	29.5	63	105	1784	4.0
409 052	3.9789	12.5	14	58.09	66.05	98	40	63	121	1788	6.0
409 051	3.9789	12.5	20	79.58	87.50	98	40	104.5	164.5	2828	10.0
409 053	3.9789	12.5	20	79.58	87.50	98	40	104.5	170.5	2828	10.0

p (mm): Teilung / pas / pitch      J (10<sup>-6</sup> kg m<sup>2</sup>): Inertia       $J_{red} = J / i^2$

**Pos. ③ Distanzstücke / Entretoise / Spacer**

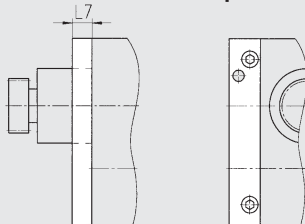

Part No.	Mat.	L <sub>7</sub>	m (kg)
409 060 ①	Alu	24	0.45
409 062 ①	Alu	41	0.66

① Lieferung paarweise / Livraison par paire / Delivery in pairs only

**Bestellbeispiel**

**Exemple de commande**

**Ordering example**

Pos. ① AE 090/S:  i:

Pos. ④

Pos. ⑤

Pos. ⑥

Zubehör

Pos. ②

Pos. ③

Angaben für speziellen Flansch und Kupplung  
 Spécification pour la bride de sortie et l'accouplement spéciale  
 Specification for special flange and coupling

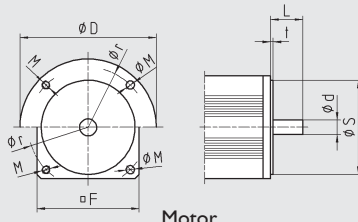

d :  [mm]      ØM :  [mm]

L :  [mm]      M : alternativ  M... [mm]

S :  [mm]      t :  [mm]

r :  [mm]

□ F :  [mm]

○ D : alternativ  [mm]

# BAUGRÖSSE 120

TAILLE 120  
SIZE 120

Hochleistungs-Schneckengetriebe

Réducteur à haute performance

Worm gear unit

**a = 120 mm**

79 ≤ L<sub>3</sub> < 110  
59 ≤ L<sub>2</sub> < 79  
33 < L<sub>1</sub> < 59

L ausgelegt für Flansch mit t<sub>1</sub> = 20mm  
L sur la base d'une épaisseur de flange t<sub>1</sub> = 20mm  
L based on a flange thickness t<sub>1</sub> = 20mm

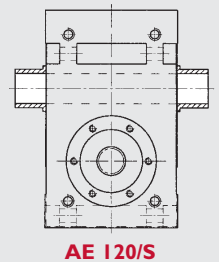
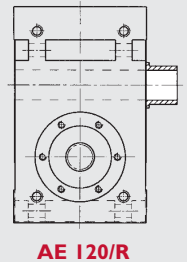
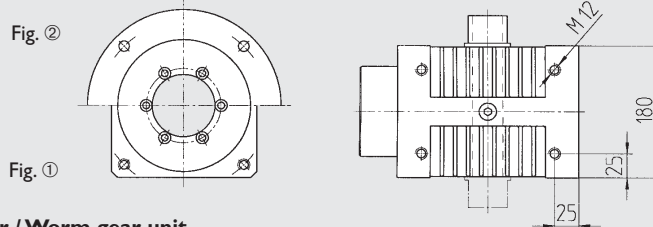
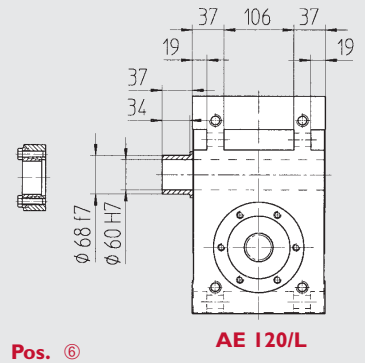
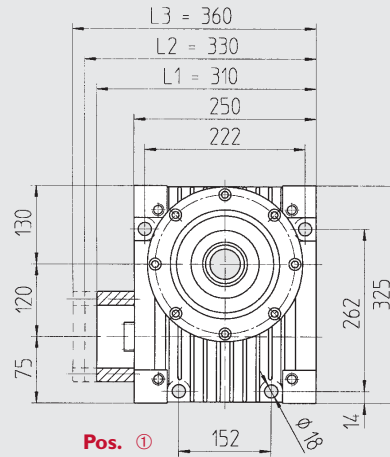
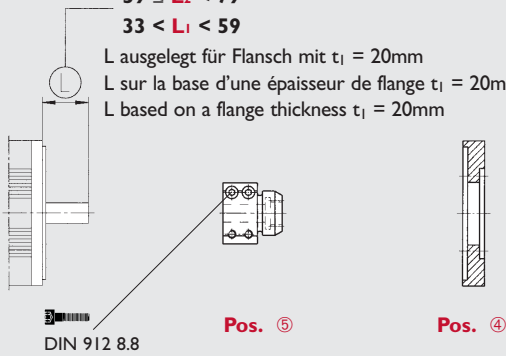

Pos. ① Getriebe / Réducteur / Worm gear unit

Type	Part No.	L <sub>1</sub>	L <sub>2</sub>	L <sub>3</sub>	Ratio i	Inertia J <sub>red</sub> (10 <sup>-5</sup> kg m <sup>2</sup> )	m (kg)
AE 120/L	412 000	412 010	412 015	2 : 1	1310	45	
AE 120/R	412 008	412 018	412 016	3 : 1	620		
AE 120/S	412 009	412 019	412 017	4 : 1	380		
				5 : 1	270		
				6 : 1	210		
				8 : 1	150		
				10 : 1	120		
				13 1/3 : 1	100		
				16 : 1	93		
				24 : 1	82		

i: ab Lager / sur stock / from stock

Pos. ④ Flansch / Bride / Flange

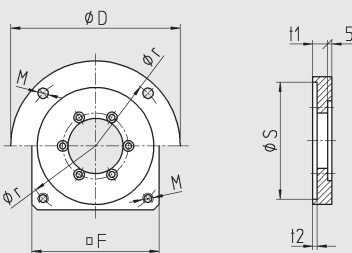

Part No.	Fig.	S	r	F	t <sub>1</sub>	t <sub>2</sub>	D	M	m (kg)
412 083	①	110.0	165	140	20	6	—	M10	1,0
412 090	①	114.3	200	174	20	6	—	M12	
412 082	①	130.0	165	142	20	6	—	M10	
412 080	①	130.0	215	192	20	6	—	M12	
412 081	①	180.0	215	190	20	6	—	M12	
412 091	①	200.0	235	220	20	6	—	M12	
412 092	①	230.0	265	250	20	6	—	M12	
412 087	①	250.0	300	260	20	6	—	M16	
412 084	②	180.0	215	—	20	6	250	ø14	
412 085	②	230.0	265	—	20	6	300	ø14	
412 086	②	250.0	300	—	20	6	350	ø18	

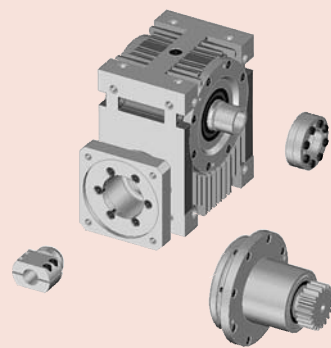

**Pos. ⑤ Kupplung / Accouplement / Coupling**

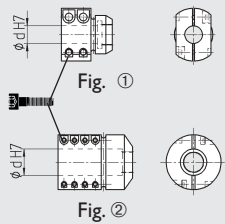

Part No.	Fig.	Inertia					
		d	J (10 <sup>-6</sup> kg m <sup>2</sup> )	T <sub>1max</sub> (Nm)	$\frac{J}{i^2}$	M <sub>A</sub> (Nm)	m (kg)
412 021	①	28	800	86	M8x30	26	1.0
412 020	①	32	800	98	M8x30		
412 023	①	35	813	107	M8x30		
412 024	①	38	760	117	M8x30		
412 025	①	42	720	129	M8x30		1.1
412 026	②	48	2040	165	M6x25	10.5	1.2

T<sub>1max</sub>: maximal übertragbares Moment der Kupplung / Couple max. de l'accouplement / Maximum torque of coupling / M<sub>A</sub>: Anziehdrehmoment / Couple de serrage / Tightening torque  
 Fig. ② nur mit L2, L3 einsetzbar / Fig. ② impose longueur L2, L3 / Fig. ② requires length L2, L3.

**Pos. ⑥ Schrumpfscheiben-Kupplung / Jonction arbre-moyeu / Tension set**

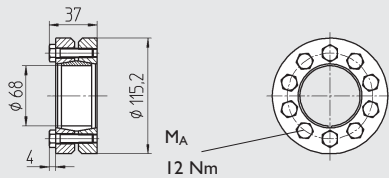

Part No.	Inertia		
	J (10 <sup>-6</sup> kg m <sup>2</sup> )	T <sub>2max</sub> (Nm)	m (kg)
412 031	3400	2500	1.5

T<sub>2max</sub>: maximal übertragbares Moment der Kupplung / Couple max. de l'accouplement / Maximum torque of coupling  
 $J_{red} = J / i^2$

**Zubehör**

**Accessoires**

**Accessories**

**Pos. ② Abtrieb mit Ritzel / Bride de sortie avec pignon / Output flange with pinion**

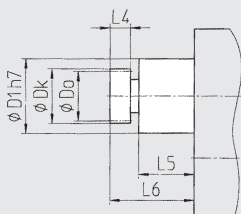

Part No.	Module	p	z	D <sub>0</sub>	D <sub>k</sub>	D <sub>I</sub>	L <sub>4</sub>	L <sub>5</sub>	L <sub>6</sub>	J	m (kg)
412 051	3.9789	12.5	26	103.45	111.4	180	40	123	181	9422	24.0
412 055	5.0930	16.0	20	101.86	112.1	180	50	123	213	10370	22.0
412 053	6.3662	20.0	20	127.32	140.1	180	60	123	238	18350	27.0

p (mm): Teilung / pas / pitch      J (10<sup>-6</sup> kg m<sup>2</sup>): Inertia       $J_{red} = J / i^2$

**Pos. ③ Distanzstücke / Entretoise / Spacer**

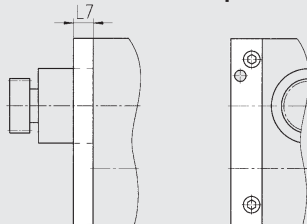

Part No.	Mat.	L <sub>7</sub>	m (kg)
412 062 ①	Alu	19	0.45
412 060 ①	Alu	34	0.60

① Lieferung paarweise / Livraison par paire / Delivery in pairs only

**Bestellbeispiel**

**Exemple de commande**

**Ordering example**

Pos. ①	AE 120/L:	412 015	i:	5:1
Pos. ④		412 080		
Pos. ⑤		412 021		
Pos. ⑥		412 030		

Zubehör	
Pos. ②	---
Pos. ③	---

Angaben für speziellen Flansch und Kupplung  
 Spécification pour la bride de sortie et l'accouplement spéciale  
 Specification for special flange and coupling

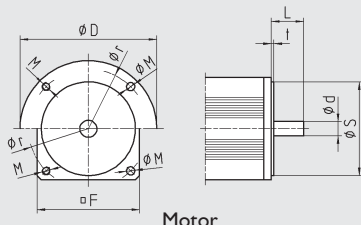

d :	<input type="text"/>	[mm]	ØM :	<input type="text"/>	[mm]
L :	<input type="text"/>	[mm]	M :	alternativ <input type="text"/>	[mm]
S :	<input type="text"/>	[mm]	t :	<input type="text"/>	[mm]
r :	<input type="text"/>	[mm]			
□ F :	<input type="text"/>	[mm]			
○ D :	alternativ <input type="text"/>	[mm]			

# BAUGRÖSSE 180

TAILLE 180  
SIZE 180

Hochleistungs-Schneckengetriebe

Réducteur à haute performance

Worm gear unit

**a = 180 mm**

L ausgelegt für Flansch mit  $t_1 = 26\text{mm}$   
L sur la base d'une épaisseur de flange  $t_1 = 26\text{mm}$   
L based on a flange thickness  $t_1 = 26\text{mm}$

$90 \leq L_2 < 120$   
 $60 < L_1 < 90$

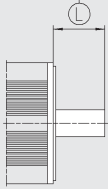

Pos. ⑤

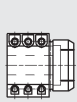

Pos. ④

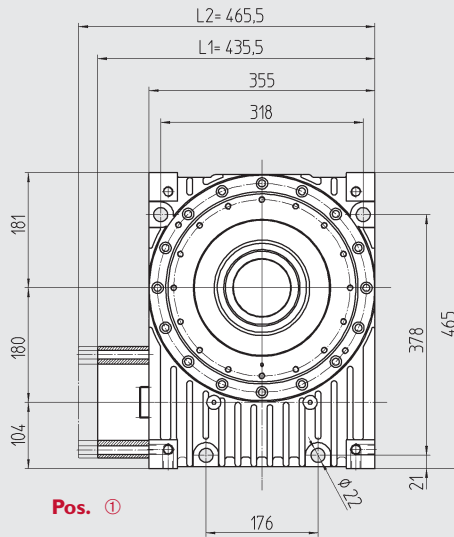

Pos. ①



Pos. ⑥

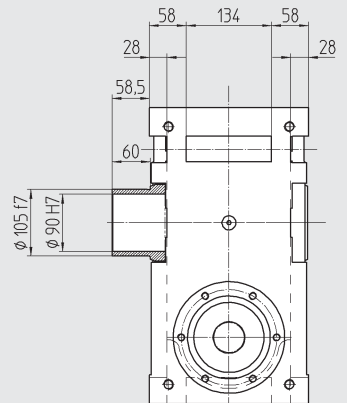

AE 180/L

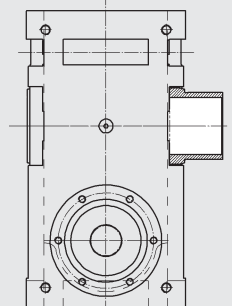
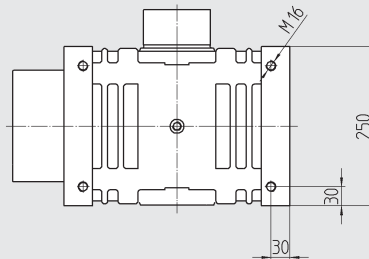
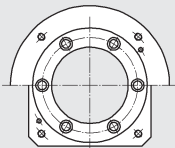

AE 180/R

**Pos. ① Getriebe / Réducteur / Worm gear unit**

Type	Part No.		Ratio i	Inertia	
	L <sub>1</sub>	L <sub>2</sub>		J <sub>red</sub> (10 <sup>-5</sup> kg m <sup>2</sup> )	m (kg)
AE 180 / L	418 000	418 010	6 : 1	1525	140
AE 180 / R	418 008	418 018	8 : 1	1095	
			10 : 1	895	
			13 1/3 : 1	740	
			16 : 1	680	
			24 : 1	603	

i: ab Lager / sur stock / from stock

**Pos. ④ Flansch / Bride / Flange**

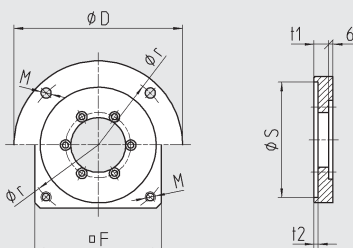

Part No.	Fig.	S	r	F	t <sub>1</sub>	t <sub>2</sub>	D	M	m (kg)
418 081	①	114.3	200	180	26	7	—	M12	2.0
418 082	①	130.0	215	192	26	7	—	M12	2.0
418 080	①	180.0	215	192	26	7	—	M12	2.0
418 083	①	200.0	235	220	26	7	—	M12	3.0
418 084	①	230.0	265	240	26	7	—	M12	4.0
418 085	①	250.0	300	260	26	7	—	M16	5.0
418 086	①	300.0	350	310	26	7	—	M16	5.0

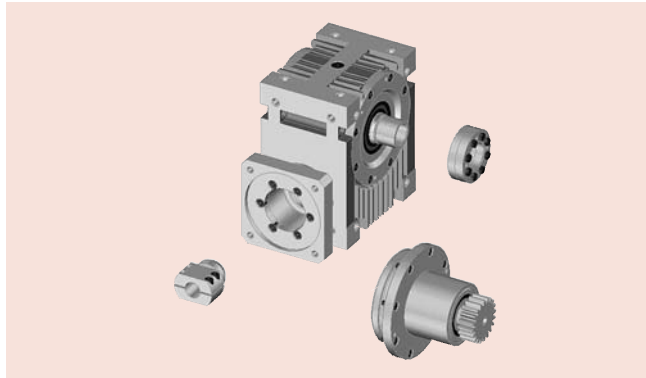

**Pos. ⑤ Kupplung / Accouplement / Coupling**

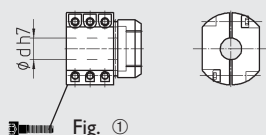

Part No.	Fig.	Inertia					
		d	J (10 <sup>-6</sup> kg m <sup>2</sup> )	T <sub>1max</sub> (Nm)		M <sub>A</sub> (Nm)	m (kg)
418 020	①	32	4080	240	M10x35	51	3.5
418 021	①	35	4050	265	M10x35		
418 022	①	38	4030	280	M10x35		
418 023	①	42	4000	315	M10x35		
418 024	①	48	3865	360	M10x35		
418 025	①	55	3670	400	M10x35		

T<sub>1max</sub>: maximal übertragbares Moment der Kupplung / Couple max. de l'accouplement / Maximum torque of coupling / M<sub>A</sub>: Anziehdrehmoment / Couple de serrage / Tightening torque

**Pos. ⑥ Schrumpfscheiben-Kupplung / Jonction arbre-moyeu / Tension set**

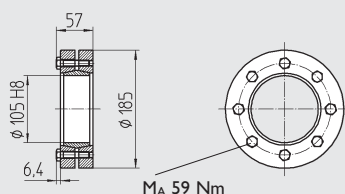

Part No.	Inertia		
	J (10 <sup>-5</sup> kg m <sup>2</sup> )	T <sub>2max</sub> (Nm)	m (kg)
418 030	4020	9000	7

T<sub>2max</sub>: maximal übertragbares Moment der Kupplung / Couple max. de l'accouplement / Maximum torque of coupling

$J_{red} = J / i^2$

**Zubehör**

**Accessoires**

**Accessories**

**Pos. ② Abtrieb mit Ritzel / Bride de sortie avec pignon / Output flange with pinion**

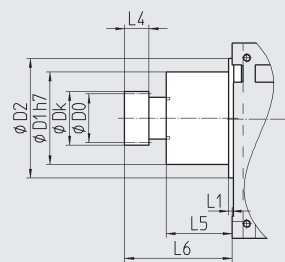

Part No.	Module	p	z	D <sub>0</sub>	D <sub>k</sub>	D <sub>1</sub>	D <sub>2</sub>	L <sub>1</sub>	L <sub>4</sub>	L <sub>5</sub>	L <sub>6</sub>	J	m (kg)
418 050	6.3662	20.0	20	127.32	140.1	220	302	10.5	60	160	240	6800	35

p (mm): Teilung / pas / pitch      J (10<sup>-5</sup> kg m<sup>2</sup>): Inertia      J<sub>red</sub> = J / i<sup>2</sup>

**Bestellbeispiel**

**Exemple de commande**

**Ordering example**

Pos. ① AE 180/L:  i:

Pos. ④

Pos. ⑤

Pos. ⑥

Zubehör

Pos. ②

Pos. ③

Einbaulage  (Seite/Page 06.29)

Angaben für speziellen Flansch und Kupplung  
 Spécification pour la bride de sortie et l'accouplement spéciale  
 Specification for special flange and coupling

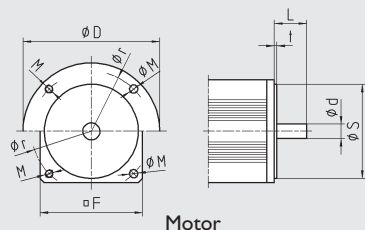

d :  [mm]       $\phi M$  :  [mm]

L :  [mm]      M : alternativ  [mm]

S :  [mm]      t :  [mm]

r :  [mm]

F :  [mm]

D : alternativ  [mm]

# BERECHNUNGSBEISPIEL

## EXEMPLE DE CALCUL CALCULATION EXAMPLE

### 1. Gegebene Größen

#### Axiallast

m	=	500 kg
v	=	1,25 m/s
t <sub>a</sub>	=	0.31 s
g	=	9.81 m/s <sup>2</sup>
μ	=	0.10
n <sub>1</sub>	=	3000 l/min
f <sub>B</sub>	=	1.2 p. 07.04
f <sub>A</sub>	=	1.1 p. 07.04
f <sub>t</sub>	=	1.0 p. 07.04
f <sub>ed</sub>	=	1.2 p. 07.04
S <sub>B</sub>	=	1.0 p. 07.04

F<sub>p</sub> (1000 mm) = 0.05 (Teilungs-Gesamtabweichung/Erreur totale de pas/Cumulative pitch error)

### 2. Gesucht

Dimension von Zahnstangen, Zahnritzel und Getriebe.

### 3. Berechnung der Kräfte auf das Antriebssystem

#### 3.1 Beschleunigung

$$a = \frac{v}{t_a} = \frac{1,25}{0,31} = 4 \text{ m/s}^2$$

#### 3.2 Vorschubkräfte horizontal

$$F_u = m \cdot g \cdot \mu + m \cdot a = 500 \cdot (9,81 \cdot 0,1 + 4) = 2490,5 \text{ N}$$

#### 3.3 Erforderliche Antriebskraft

$$F_{erf} = f_B \cdot F_u = 1,2 \cdot 2490,5 = 2989,0 \text{ N}$$

### 4. Wahl von Zahnstangen und Ritzel

#### 4.1 F<sub>N</sub> aus Tabelle page 03.03 mit S<sub>B</sub>=1.0 Bedingung: F<sub>2N</sub> ≥ F<sub>erf</sub>

Ritzel/pignon/pinion

Zahnstange/crémaillères/rack

### 5. Auslegung des Getriebes

#### 5.1 Übersetzung

$$n_2 = \frac{v}{D_0 \cdot \pi} \cdot 60000 = \frac{1,25}{79,577 \cdot \pi} \cdot 60000 = 300 \text{ l/min}$$

$$i_{Ger} = \frac{n_1}{n_2} = \frac{3000}{300} = 10:1$$

#### 5.2 Drehmoment am Abtrieb

$$T_2 = \frac{F_u \cdot D_s}{2000} = \frac{2491 \cdot 79,577}{2000} = 99,1 \text{ Nm}$$

#### 5.3 Erforderliches Drehmoment

$$T_{2erf} = T_2 \cdot f_B \cdot f_A \cdot f_i \cdot f_{ed} = 99,1 \cdot 1,2 \cdot 1,1 \cdot 1,0 \cdot 1,2 = 157 \text{ Nm}$$

T<sub>2N</sub> aus Tabelle Seite 07.05  
Bedingung: T<sub>2N</sub> ≥ T<sub>2erf</sub>

Getriebe/réducteur/gear box:

### 1. Données

#### Charge axiale

### 2. Demandés

Dimension du système d'entraînement et du réducteur.

### 3. Forces sur le système d'entraînement

#### 3.1 Accélération

#### 3.2 Forces de traction horizontale

#### 3.3 Forces de traction exigée

### 4. Sélection crémaillère et pignon

#### 4.1 F<sub>N</sub> de la table page 03.03 avec S<sub>B</sub>=1.0 Condition: F<sub>2N</sub> ≥ F<sub>erf</sub>

p = 12,5 z = 20 Part. No. 409 041

p = 12,5 Part. No. 152 125

### 5. Sélection du réducteur

#### 5.1 Rapport

#### 5.2 Couple de sortie

#### 5.3 Couple nécessaire

T<sub>2N</sub> du tableau de charge page 07.05  
Condition: T<sub>2N</sub> ≥ T<sub>2erf</sub>

AE 090 i = 10:1

### 1. Determine knowns

#### Axial load

m	=	_____ kg
v	=	_____ m/s
t <sub>a</sub>	=	_____ s
g	=	9.81 m/s <sup>2</sup>
μ	=	_____
n <sub>1</sub>	=	_____ l/min
f <sub>B</sub>	=	_____ p. 07.04
f <sub>A</sub>	=	_____ p. 07.04
f <sub>t</sub>	=	_____ p. 07.04
f <sub>ed</sub>	=	_____ p. 07.04
S <sub>B</sub>	=	_____ p. 07.04

F<sub>p</sub> (1000 mm) = \_\_\_\_

### 2. Determine unknowns

Dimension of rack, pinion and servo gear box.

### 3. Forces acting on the drive system

#### 3.1 Acceleration

$$a = \text{_____ m/s}^2$$

#### 3.2 Horizontal traction forces

$$F_u = \text{_____ N}$$

#### 3.3 Required drive forces

$$F_{erf} = \text{_____ N}$$

### 4. Selection of racks and pinions

#### 4.1 F<sub>N</sub> from table page 03.03 with S<sub>B</sub>=1.0 Condition: F<sub>2N</sub> ≥ F<sub>erf</sub>

Part. No. \_\_\_\_\_

Part. No. \_\_\_\_\_

### 5. Selection of gear box

#### 5.1 Ratio

$$n_2 = \text{_____ l/min}$$

$$i_{Ger} = \text{_____}$$

#### 5.2 Output torque

$$T_2 = \text{_____ Nm}$$

#### 5.3 Required torque

$$T_{2erf} = \text{_____ Nm}$$

T<sub>2N</sub> from load table page 07.05  
Condition: T<sub>2N</sub> ≥ T<sub>2erf</sub>

AE \_\_\_\_\_

# WARTUNG UND SCHMIERUNG

## ENTRETIEN ET LUBRIFICATION MAINTENANCE AND LUBRICATION

### 1. Applikation

- Beschreibung der Anwendung.

### 2. Anforderungen an Antrieb

- Kleine Abmasse mit hohen übertragbaren Momenten
- Positioniergenauigkeit
- Laufruhe
- Anzahl Lastwechsel / h

### 3. Betriebsdaten

- Dauerbetrieb oder intermittierender Betrieb (Anläufe / h)
- Einschaltdauer
- Eintriebsdrehzahl
- Art der Eintriebsdrehzahl (variabel, kontinuierlich)
- Gewünschte Abtriebsdrehzahl
- Zu bewegende Masse
- Gewünschte Geschwindigkeit der bewegten Masse
- Beschleunigungszeit
- Art des Einbaus des Zahnstangensystems

### 4. Umgebung

- Umgebungstemperatur
- Feuchtigkeit

### 5. Konfiguration

- Zubehör
- Anbaugeometrie Motor
- Art des Abtriebs
- Spezielle Modifikationen, Dimensionen oder Eigenschaften

### Schmierung

Die Getriebe werden im Werk mit einem synthetischen Öl gefüllt. Die Erstfüllung erfolgt mit Glygoyl 460 von Mobil. Jede Nachfüllung muss mit einem ebensolchen synthetischen Öl erfolgen. Bei einschichtigem Betrieb wird nach fünfjähriger Laufzeit ein Ölwechsel empfohlen. Bei dreischichtigem Betrieb empfiehlt sich ein zweijähriger Wechsel. Beim Ölwechsel muss das Getriebe entsprechend durchgespült werden.

### 1. Application

- Description de l'application.

### 2. Caractéristiques demandés

- Hautes couples transmissible avec petites dimensions
- Précision de positionnement
- Roulement
- Changement de charge / h

### 3. Indications

- Fréquence de démarrage (démarrage / h)
- Cycle de service
- Vitesse d'entrée
- Caractéristique de la vitesse d'entrée (variable, continu)
- Vitesse de sortie exigée
- Poids à bouger
- Vitesse exigée du poids
- Temps d'accélération
- Position de montage du système d'entraînement

### 4. Environnement

- Température ambiante
- Humidité

### 5. Configuration

- Accessoires
- Dimensions pour montage du moteur
- Spécial modifications, dimensions ou propriétés

### Lubrification

Les réducteurs sont remplis à l'usine avec une huile synthétique. Le plein initial se fait avec de la Glygoyl 460 de Mobil. Chaque plein ultérieur devra également se faire avec une huile synthétique. En cas de travail en une équipe, une vidange d'huile devra avoir lieu au bout de cinq ans de marche. En cas de travail en trois équipes, il est recommandé de faire la vidange au bout des deux ans. Lors de vidange d'huile, le réducteur devra être rincé de manière appropriée.

### 1. Application

- Description of application.

### 2. Required features

- Small sizes with high torques
- Positioning accuracy
- Rolling
- Shock loading

### 3. Loading

- Continuous or intermittent (start per hour)
- Duty cycle
- Preferred input speed
- Variable or continuous input speed
- Desired output speed
- Moving mass
- Preferred speed of the moved mass
- Acceleration time
- Overhung and thrust loading on shafts
- Arrangement type of the drive system

### 4. Environmental

- Temperature
- Wet or spray exposure

### 5. Configuration

- Accessories
- Flange mounting provisions for the drive motor
- Specification of output
- Special modifications, dimensions or features

### Lubrification

The worm gear unit is filled with a synthetic oil at the factory. The first filling is carried out using Glygoyl 460 from Mobil. Every refill must also be carried out using a synthetic oil of this kind. For single-shift operation, an oil change should take place after five years of operation. For three-shift operation, we recommend an oil change after two years. During the oil change, the gear box must be firstly flushed through.

### Schmierstoff

#### Lubrificant Lubricant





#### Getriebe

##### Réducteur

Worm gear unit	Mobil	Degol	BP Energol	Pinnacle	Tivela	Tribol	Klübersynth
Schienen	Glygoyl HE460	GS 460	SG-XP 460	460	S460	460	GH6-220

#### Rails/Guideways

##### Getriebekupplung

##### L'accouplement

Coupling	Mobilux	Aralup	BP Energol	Multifak	Alvania	Tribol	Centoplex
Verzahnung	EP 2	HLP 2	LS-EP 2	EP 2	EP-2	3030	EP-2

#### Denture/Gear teeth

#### Ölmenge für Getriebe

#### Quantité d'huile pour les réducteurs

#### Oil quantity for worm gear units

Typ	030	045	060	090	120	180	
V (cm <sup>3</sup> )	40	100	250	700	1400	gemäss Typenschild/selon plaque according name plate	

Ölmenge / Einbaulage  
für Getriebe Typ 180 Seite 06.29

Quantité d'huile / position de montage  
pour les réducteurs Typ 180 page 06.29











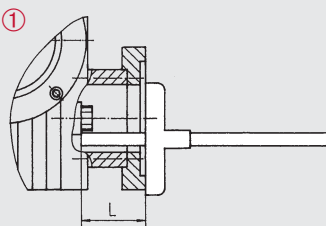
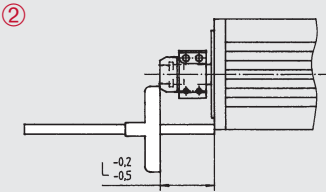
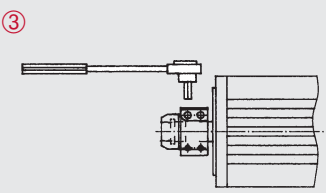
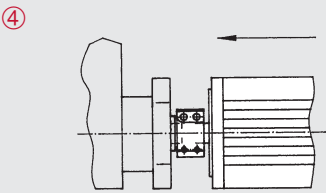
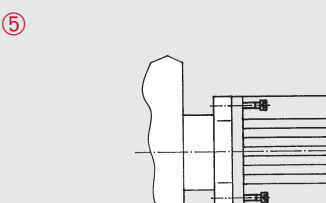

Oil quantity / mounting orientation  
for worm gear units Typ 180 page 06.29





# EINBAU UND AUSBAU

## MONTAGE ASSEMBLY

Typ FA / FH / AE	Type FA / FH / AE						Typ FA / FH / AE																																										
<b>Montage von Motor und Kupplung</b>  <p>①</p>  <p>②</p>  <p>③</p>  <p>④</p>  <p>⑤</p>	<b>Mode d'emploi pour montage du moteur et de l'accouplement</b> <p>① Kontrolle des Masses L. Distanz von Flansch auf Innenring.</p> <p>② Kupplung und Motorwelle fettfrei reinigen. Kupplung auf Motorwelle schieben. Mass L mit der Toleranz - 0.2 / - 0.5 überprüfen und Schrauben leicht anziehen.</p> <p>③ Schrauben mit Drehmomentschlüssel gemäss Tabelle anziehen.</p> <table border="1"> <thead> <tr> <th>Typ</th> <th>030</th> <th>045</th> <th>060</th> <th>090</th> <th>120</th> <th>180</th> </tr> </thead> <tbody> <tr> <td></td> <td>M3x16</td> <td>M4x16</td> <td>M6x20/M4x16</td> <td>M8x30/M6x20</td> <td>M8x30/M6x25</td> <td>M10x35</td> </tr> <tr> <td>M<sub>A</sub> (Nm)</td> <td>1.37</td> <td>3.1</td> <td>10.5/3.12</td> <td>26/10.5</td> <td>26/10.5</td> <td>51</td> </tr> </tbody> </table> <p>④ Motor mit leichter Drehung auf Kupplung schieben.</p> <p>⑤ Fixierung des Motors an das Getriebe.</p>						Typ	030	045	060	090	120	180		M3x16	M4x16	M6x20/M4x16	M8x30/M6x20	M8x30/M6x25	M10x35	M <sub>A</sub> (Nm)	1.37	3.1	10.5/3.12	26/10.5	26/10.5	51	<b>Procedure for mounting of motor and coupling</b> <p>① Contrôler la côte L, distance entre la bride et la bague intérieure.</p> <p>② Nettoyer l'accouplement et l'arbre du moteur en éliminant la graisse. Glisser l'accouplement sur l'arbre du moteur. Contrôler la cote L avec tolérance - 0.2 / - 0.5, puis serrer modérément les vis.</p> <p>③ Serrer les vis conformément au tableau, à l'aide d'une clé dynamométrique.</p> <table border="1"> <thead> <tr> <th>Typ</th> <th>030</th> <th>045</th> <th>060</th> <th>090</th> <th>120</th> <th>180</th> </tr> </thead> <tbody> <tr> <td></td> <td>M3x16</td> <td>M4x16</td> <td>M6x20/M4x16</td> <td>M8x30/M6x20</td> <td>M8x30/M6x25</td> <td>M10x35</td> </tr> <tr> <td>M<sub>A</sub> (Nm)</td> <td>1.37</td> <td>3.1</td> <td>10.5/3.12</td> <td>26/10.5</td> <td>26/10.5</td> <td>51</td> </tr> </tbody> </table> <p>④ Glisser le moteur sur l'accouplement en exerçant une légère rotation.</p> <p>⑤ Fixer le moteur sur le réducteur.</p>	Typ	030	045	060	090	120	180		M3x16	M4x16	M6x20/M4x16	M8x30/M6x20	M8x30/M6x25	M10x35	M <sub>A</sub> (Nm)	1.37	3.1	10.5/3.12	26/10.5	26/10.5	51
Typ	030	045	060	090	120	180																																											
	M3x16	M4x16	M6x20/M4x16	M8x30/M6x20	M8x30/M6x25	M10x35																																											
M <sub>A</sub> (Nm)	1.37	3.1	10.5/3.12	26/10.5	26/10.5	51																																											
Typ	030	045	060	090	120	180																																											
	M3x16	M4x16	M6x20/M4x16	M8x30/M6x20	M8x30/M6x25	M10x35																																											
M <sub>A</sub> (Nm)	1.37	3.1	10.5/3.12	26/10.5	26/10.5	51																																											
	<table border="1"> <thead> <tr> <th>Typ</th> <th>030</th> <th>045</th> <th>060</th> <th>090</th> <th>120</th> <th>180</th> </tr> </thead> <tbody> <tr> <td></td> <td>M3x16</td> <td>M4x16</td> <td>M6x20/M4x16</td> <td>M8x30/M6x20</td> <td>M8x30/M6x25</td> <td>M10x35</td> </tr> <tr> <td>M<sub>A</sub> (Nm)</td> <td>1.37</td> <td>3.1</td> <td>10.5/3.12</td> <td>26/10.5</td> <td>26/10.5</td> <td>51</td> </tr> </tbody> </table>						Typ	030	045	060	090	120	180		M3x16	M4x16	M6x20/M4x16	M8x30/M6x20	M8x30/M6x25	M10x35	M <sub>A</sub> (Nm)	1.37	3.1	10.5/3.12	26/10.5	26/10.5	51																						
Typ	030	045	060	090	120	180																																											
	M3x16	M4x16	M6x20/M4x16	M8x30/M6x20	M8x30/M6x25	M10x35																																											
M <sub>A</sub> (Nm)	1.37	3.1	10.5/3.12	26/10.5	26/10.5	51																																											
	<p>④ Check the dimension L, the distance from the flange to the inner bore.</p> <p>⑤ Clean the coupling and the motor shaft so that it is free of grease. Push the coupling into the motor shaft. Check dimension L with tolerance - 0.2 / - 0.5, and lightly tighten the screws.</p> <p>⑥ Tighten the screws according to the table, using a torque wrench.</p> <table border="1"> <thead> <tr> <th>Typ</th> <th>030</th> <th>045</th> <th>060</th> <th>090</th> <th>120</th> <th>180</th> </tr> </thead> <tbody> <tr> <td></td> <td>M3x16</td> <td>M4x16</td> <td>M6x20/M4x16</td> <td>M8x30/M6x20</td> <td>M8x30/M6x25</td> <td>M10x35</td> </tr> <tr> <td>M<sub>A</sub> (Nm)</td> <td>1.37</td> <td>3.1</td> <td>10.5/3.12</td> <td>26/10.5</td> <td>26/10.5</td> <td>51</td> </tr> </tbody> </table> <p>④ Push the motor into the coupling while rotating slightly.</p> <p>⑤ Secure the motor to the gearbox.</p>						Typ	030	045	060	090	120	180		M3x16	M4x16	M6x20/M4x16	M8x30/M6x20	M8x30/M6x25	M10x35	M <sub>A</sub> (Nm)	1.37	3.1	10.5/3.12	26/10.5	26/10.5	51																						
Typ	030	045	060	090	120	180																																											
	M3x16	M4x16	M6x20/M4x16	M8x30/M6x20	M8x30/M6x25	M10x35																																											
M <sub>A</sub> (Nm)	1.37	3.1	10.5/3.12	26/10.5	26/10.5	51																																											

## Typ AE

### Anleitung für Nachstellen des Getriebespiels

①

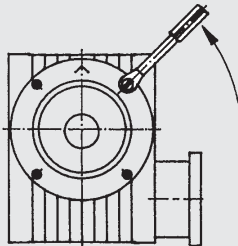

②

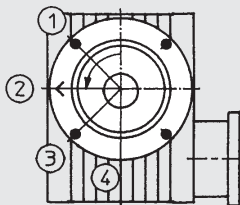

③

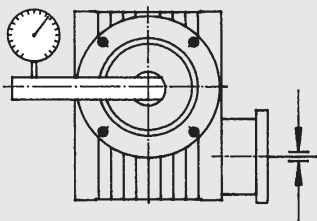

④

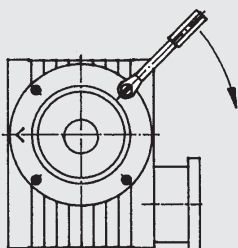

⑤

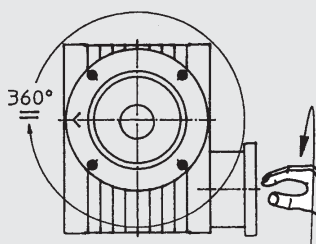

## Type AE

### Mode d'emploi pour le rattrapage du jeu

Die Getriebe werden im Werk auf ein maximales Verzahnspiel von <math>6'</math> eingestellt. Erhöht sich das Verzahnspiel nach längerem Gebrauch um min. <math>8'</math> kann das Verzahnspiel wie folgt neu eingestellt werden.

- ① Schrauben der seitlichen Gehäusedeckel beidseitig lösen. Deckel nicht demontieren wegen Ölaustritt.
- ② Drehen der beiden Deckel zur nächst höheren am Gehäuse eingegossenen Zahl. Zwischenstellungen sind möglich. Beide Deckel müssen identische Positionen haben.
- ③ Kontrolle des Verdrehflankenspiels bei arretierter Schneckenwelle. Falls erforderlich weiter nachstellen gemäss Position 2.
- ④ Schrauben mit Drehmomentschlüssel gemäss Tabelle anziehen.

Typ	AE 030	AE 045	AE 060	AE 090	AE 120	AE 180
	M6x10	M6x12	M6x12	M8x20	M10x20	M10x35
M <sub>A</sub> (Nm)	6	7	9	24	40	48

- ⑤ Kontrolle: Drehen der Schneckenwelle.

Radsatz darf über die volle Umdrehung der Abtriebswelle nicht klemmen.

Le jeu de denture des réducteurs est réglé en usine sur un maximum de <math>6'</math>. Si le jeu de denture augmente d'au moins <math>8'</math> après un certain temps d'utilisation, le jeu de denture peut être de nouveau réglé comme suit:

- ① Desserrer les vis des couvercles latéraux sur les deux côtés. Ne pas démonter les couvercles à cause des fuites d'huile.
- ② Tourner les deux couvercles jusqu'au prochain chiffre supérieur indiqué sur le boîtier. Des positions intermédiaires sont possibles. Les deux couvercles doivent avoir une position identique.
- ③ Contrôler le jeu primitif selon position 2, l'arbre de vis sans fin étant à l'arrêt. Si nécessaire, poursuivre le réglage selon position 2.
- ④ Serrer les vis conformément au tableau, au moyen d'une clé dynamométrique.

Typ	AE 030	AE 045	AE 060	AE 090	AE 120	AE 180
	M6x10	M6x12	M6x12	M8x20	M10x20	M10x35
M <sub>A</sub> (Nm)	6	7	9	24	40	48

- ⑤ Contrôle: tourner l'arbre de vis sans fin. Le train de roues ne doit pas coincer lors de la rotation complète de l'arbre de vis sans fin.

The gearboxes are set to a minimum backlash of <math>6'</math> at the factory. If the backlash increases to a min. <math>8'</math> after long use, the backlash can be re-adjusted as follows:

- ① Loosen the cover retaining screws on both sides of the housing. Do not remove the covers as it may result in loss of oil.
- ② Rotate the covers in the direction of the next higher number indicated on the housing. Intermediate positions (between numbers) may be selected. Both covers must be set to identical positions.
- ③ To check the backlash the worm shaft must be in a locked position. If additional adjustment is required, repeat as described in step No. 2.
- ④ Tighten the screws according to the table, using a torque wrench.

Typ	AE 030	AE 045	AE 060	AE 090	AE 120	AE 180
	M6x10	M6x12	M6x12	M8x20	M10x20	M10x35
M <sub>A</sub> (Nm)	6	7	9	24	40	48

- ⑤ Check: Turn the input shaft. The worm gear must not bind while the output shaft turns a full <math>360^\circ</math> rotation.



# MOTOREN-APPLIKATION



## APPLICATION POUR DES MOTEURS MOTOR APPLICATIONS

Die Auflistung der Motoren erfolgt gemäss der Anbaubarkeit an die betreffende Getriebe-grösse.  
Für die korrekte Getriebeauslegung sind die Leistungstabellen massgebend.

Les moteurs sont classés selon la montabilité avec les tailles de réducteur.  
Pour la sélection du réducteur le tableau de caractéristiques est déterminant.

The motors are listed according to whether the units can be fitted to the gear box size.  
The correct power ratings have to be determined with the load tables.

		Baugrösse/Taille/Size					Type FA / FH / AE	Part No. 	Part No. 	
		030	045	060	090	120				
<b>ABB</b>	T4C1 bis C4			●			060../L2	406089	406021	
	T5C2 bis C4			●			060../L3	406080	406020	
					●		090../L1	409082	409022	
	T4F1 bis F3			●			060../L2	406089	406021	
	T7F2 bis F4				●		090../L2	409081	409024	
					●	120../L2	412081	412024		
<b>Allen-Bradley</b>	I326AB-B410 /-B420 /-B430		●				045../L2	404583	404520	
				●			060../L2	406084	406021	
	I326AB-B515 / -B520 /-B530				●		060../L3	406080	406020	
					●		090../L1	409082	409022	
	I326AB-B720 / -B730 /-B740				●		090../L1	409081	409020	
						●	120../L2	412081	412020	
	F-4030 / F-4050 / F-4075			●			060../L3	406091	406021	
						●	090../L2	409092	409028	
	F-6100 / F-6200 / F-6300				●		120../L3	412090	412023	
			●				030..	403082	403021	
	H-2005		●				045../L1	404582	404522	
	H-3007 / H-3016	●					030..	403080	403020	
			●				045../L1	404580	404521	
H-4030			●			060../L3	406091	406021		
H-4050 / H-4075										
H-6100 / H-6200 / H-6300				●		090../L2	409092	409028		
					●	120../L3	412090	412023		
H-8350 / H-8500					●	120../L3	412092	412025		
<b>AMK</b>	DV-4	●					030..	403086	403020	
			●				045../L1	404585	404521	
	DV-5		●				045../L2	404583	404520	
				●			060../L2	406084	406021	
	DV-7			●			060../L3	406080	406020	
					●		090../L1	409082	409022	
	DV-10				●		090../L1	409081	409020	
					●	120../L2	412081	412020		

		Baugröße/Taille/Size					Type	Part No.	Part No.	
		030	045	060	090	120	FA / FH / AE			
<b>Baldor</b>	BSM 50	●					030..	403083	403022	
	BSM 63	●					030..	403082	403021	
	BSM 80		●				045../L1	404582	404522	
				●			045../L2	404580	404520	
	BSM 90			●			060../L2	406085	406021	
					●		060../L3	406089	406020	
<b>Baumüller</b>	DS 36	●					090../L1	409089	409022	
	DS 45	●					090../L1	409082	409021	
	DS 56		●				090../L1	409081	409020	
				●			120../L2	412081	412020	
	DS 71			●			030..	403082	403021	
	DS 100			●	●		045../L1	404582	404522	
<b>Bosch Rexroth</b>	SE-D1	●					030..	403082	403021	
	SE-B2		●				045../L1	404582	404522	
				●			045../L1	404583	404521	
	SE-B3			●			060../L2	406089	406021	
	SE-LB3		●				090../L1	409089	409023	
				●			045../L2	404583	404520	
	SE-B4/-C4			●			060../L2	406084	406021	
					●		060../L3	406080	406020	
	SE-B5				●		090../L1	409082	409022	
	SR-A0		●					090../L1	409081	409020
							●	120../L2	412081	412020
	SR-A1	●					030..	403083	403022	
	SF(R)-A2			●				030..	403082	403021
				●				045../L1	404582	404522
	SF(R)-A3			●			045../L1	404583	404521	
	SF(R)-A4				●			060../L2	406089	406021
				●			090../L1	409089	409023	
SF(R)-A5				●			060../L3	406080	406020	
					●		090../L1	409082	409022	
					●		090../L1	409081	409020	
<b>Fanuc</b>	α 0.5	●					120../L2	412081	412020	
	β 0.5		●				030..	403090	403022	
	α 1/2	●					030..	403087	403025	
				●				045.. L2	404594	ø10 404529
	α 3/6			●			060../L2	406092	406021	
	α 12/22/30/40				●			090../L1	409091	409023
						●		090../L2	409092	409028
						●	120../L2	412090	412023	
	β 1/2			●				045.. L1	404587	404521
					●			060.. L2	406084	ø14 406029
β 3/6			●				060..L2	406093	406021	
					●		090.. L1	409094	409023	





# MOTOREN-APPLIKATION

## APPLICATION POUR DES MOTEURS MOTOR APPLICATIONS

Die Auflistung der Motoren erfolgt gemäss der Anbaubarkeit an die betreffende Getriebegrösse.  
Für die korrekte Getriebeauslegung sind die Leistungstabellen massgebend.

Les moteurs sont classés selon la montabilité avec les tailles de réducteur.  
Pour la sélection du réducteur le tableau de caractéristiques est déterminant.

The motors are listed according to whether the units can be fitted to the gear box size.  
The correct power ratings have to be determined with the load tables.

		Baugrösse/Taille/Size					Type FA / FH / AE	Part No. 	Part No. 
		030	045	060	090	120			
<b>Georg II Kobold</b>	KSY 06..	●					030..	403083	403022
	KSY 26..	●					030..	403082	403021
			●				045../L1	404582	404522
	KSY 46..		●				045../L2	404583	404520
				●			060../L2	406084	406021
	KSY 66..			●			060../L3	406086	406020
	KSY 86..				●		090../L1	409082	409022
					●		090../L1	409081	409020
						●	120../L2	412081	412020
<b>Bosch Rexroth</b>	MDD / MAC / MKD 025	●					030..	403083	403022
	MDD / MAC / MHD /	●					030..	403081	403020
	MKD 041		●				045../L1	404581	404521
	MDD 065		●				045../L1	404583	404521
				●			060../L1	406084	ø14 406029
	MAC 063		●				045../L1	404583	404521
				●			060../L1	406084	ø14 406029
	MAC 092			●			060../L1	406082	ø14 406029
	MDD / MAC / MHD /			●			060../L2	406083	406021
	MKD 071				●		090../L1	409084	409023
	MDD / MAC / MHD / MKD 090			●			060../L3	406081	406020
					●		090../L1	409083	409022
	MDD / MAC / MKD 093			●			060../L3	406081	406020
					●		090../L1	409083	409022
	MHD 093				●		090../L1	409082	409020
						●	120../L2	412082	412020
	MDD / MAC / MHD / MKD 112				●		090../L1	409080	409020
					●	120../L2	412080	412020	
MDD / MAC / MKD 115				●		090../L1	409080	409020	
					●	120../L2	412080	412020	
MHD 115				●		090../L2	409081	409024	
					●	120../L3	412081	412024	

ISOflux		Baugröße/Taille/Size					Type FA / FH / AE	Part No.	Part No.
		030	045	060	090	120			
	443			●			060../L2	406089	406021
	444/544			●			060../L2	406089	406021
	445/545			●			060../L3	406080	406020
					●		090../L1	409082	409022
	446				●		090../L2	409081	409020
						●	120../L3	412081	412020
	448					●	120../L3	412087	412026
	641.x.xx.l...	●					045../L2	404583	404520
				●			060../L2	406084	406021
	651.x.xx.l...	●					045../L2	404583	404520
				●			060../L2	406084	406021
	644.x.xx.0...			●			060../L2	406089	406021
	644.x.xx.l...			●			060../L2	406084	406021
	654.x.xx.0...			●			060../L2	406089	406021
	654.x.xx.l...			●			060../L2	406084	406021
	645.x.xx.0...			●			060../L3	406080	406020, 406023
					●		090../L1	409082	409022, 409020
						●	120../L2	412082	412020
	645.x.xx.l...				●		090../L1	409081	409022, 409020
						●	120../L2	412081	412020
	744.x.xx.0...			●			060../L2	406089	406021
	744.x.xx.l...	●		●			045../L2	404583	404520
				●			060../L2	406084	406021
	744.x.xx.4...			●			060../L3	406081	406020
					●		090../L1	409083	409022
	754.x.xx.0...			●			060../L2	406089	406021
	754.x.xx.l...	●		●			045../L2	404583	404520
				●			060../L2	406084	406021
	754.x.xx.9...			●			060../L3	406081	406020
					●		090../L1	409083	409022
	745.x.xx.0...			●			060../L3	406080	406020
					●		090../L1	409082	409022
	745.x.xx.l...				●		090../L1	409081	409022
	745.x.xx.4...				●		090../L1	409080	409020
						●	120../L2	412080	412020
	755.x.xx.0...			●			060../L3	406080	406020
					●		090../L1	409082	409022
	755.x.xx.l...				●		090../L1	409081	409022
	755.x.xx.4...				●		090../L1	409080	409020
						●	120../L2	412080	412020
	861.x.xx.l...	●					045../L2	404583	404520
				●			060../L2	406084	406021
	864.x.xx.0...			●			060../L2	406089	406021
					●		090../L1	409089	409023
	864.x.xx.l...	●					045../L2	404583	404520
				●			060../L2	406084	406021
	864.x.xx.9...			●			060../L3	406080	406020
					●		090../L1	409082	409022
	865.x.xx.0...			●			060../L2, L3	406080	406020, 406023
					●		090../L1	409082	409022, 409020
						●	120../L2	412082	412020





# MOTOREN-APPLIKATION

## APPLICATION POUR DES MOTEURS MOTOR APPLICATIONS

Die Auflistung der Motoren erfolgt gemäss der Anbaubarkeit an die betreffende Getriebe-grösse.  
Für die korrekte Getriebeauslegung sind die Leistungstabellen massgebend.

Les moteurs sont classés selon la montabilité avec les tailles de réducteur.  
Pour la sélection du réducteur le tableau de caractéristiques est déterminant.

The motors are listed according to whether the units can be fitted to the gear box size.  
The correct power ratings have to be determined with the load tables.

		Baugrösse/Taille/Size					Type FA / FH / AE	Part No. 	Part No. 
		030	045	060	090	120			
<b>Lenze</b>	MDSKS..036-13-35	●					030..	403082	403021
			●				045../L1	404582	404522
	MDSKS..036-23-35	●					030..	403082	403021
				●			045../L1	404582	404522
	MDSKS..056-23-51	●					030..	403080	403020
				●			045../L1	404580	404521
	MDSKS..056-33-51	●					030..	403080	403020
				●			045../L1	404580	404521
	MDxKS..071-13-65				●		060../L2	406089	406021
	MDxKS..071-23-65				●		060../L2	406089	406021
	MDxKS..071-33-65				●		060../L2	406089	406021
	MDSKA..056-22-51	●					030..	403080	403020
				●			045../L1	404580	404521
	MDxKA..071-22-65				●		060../L2	406089	406021
						●	090../L1	409089	409023
MDxKA..080-22-71				●		060../L3	406080	406020	
					●	090../L1	409082	409022	
MDxKA..090-22-83					●	090../L1	409082	409022	
MDxKA..100-22-96					●	090../L1	409081	409021	
						●	120../L2	412081	412021
MDxKA..112-22-107						●	120../L3	412081	412024
MDxKA..112-22-125						●	120../L3	412092	412024
<b>Parvex</b>	HX / LX 3..	●					030..	403082	403021
			●				045../L1	404582	404522
	HX / LX 4..		●				045../L2	404580	404520
				●			060../L2	406085	406021
	HX / LX 6..			●			060../L3	406089	406020
					●		090../L1	409089	409022
	HS 6..			●			060../L3	406089	406020
					●		090../L1	409089	409022
	HD 6..			●			060../L3	406089	406020
					●		090../L1	409089	409022
	HS 8..				●		090../L1	409081	409020
						●	120../L2	412081	412020
	HD 8..				●		090../L1	409081	409020
					●	120../L2	412081	412020	
HS 9..				●		090../L1	409081	409020	
					●	120../L2	412081	412020	
HD 9..				●		090../L1	409081	409020	
					●	120../L2	412081	412020	

		Baugröße/Taille/Size					Type FA / FH / AE	Part No.	Part No.
		030	045	060	090	120			
Seidel	6SM27	●					030..	403083	403022
	6SM37	●					030..	403091	403021
			●				045../L1	404592	404522
	6SM45	●					030..	403080	403020
			●				045../L1	404580	404521
	6SM47	●					030..	403080	403020
			●				045../L1	404580	404521
	6SM56		●				045../L2	404583	404520
				●			060../L2	406084	406021
	6SM57		●				045../L2	404583	404520
				●			060../L2	406084	406021
	6SM71				●		090../L1	409082	409022
	6SM77				●		090../L1	409082	409022
	6SM100				●		090../L1	409081	409020
					●	120../L2	412081	412020	
6SM109M				●		090../L1	409081	409020	
					●	120../L2	412081	412020	
Siemens	I FT5 042/044/046	●					030..	403080	403020
			●				045../L1	404580	404521
	I FT5 062/064/066		●				045../L2	404583	404520
				●			060../L2	406084	406021
	I FT5 072/074/076			●			060../L3	406080	406020
					●		090../L1	409082	409022
	I FT5 102/104*/106*/108				●		090../L1	409081	409020
						●	120../L2	412081	412020
	I FT5 132*/134*/136*/138					●	120../L3	412087	412026
	I FT5 070*/071*/073*			●			060../L1	406088	406021
	I FT5 101*/103*				●		090../L1	409087	409021
	I FT6 031/034	●					030..	403082	403020
			●				045../L1	404582	404521
	I FT6 041*/044		●				045../L2	404580	404520
				●			060../L2	406085	406021
	I FT6 061/062/064			●			060../L3	406089	406020
					●		090../L1	409089	409022
	I FT6 081*/082/084/086			●			060../L3	406080	406023
					●		090../L1	409082	409020
						●	120../L2	412082	412020
	I FT6 102*/105*/108*				●		090../L2	409081	409024
						●	120../L3	412081	412024
I FT6 132*/134/136					●	120../L3	412087	412026	
FK 6 040/042		●				045../L2	404580	404520	
			●			060../L2	406085	406021	
FK6 060/063			●			060../L3	406089	406020	
				●		090../L1	409089	409022	
FK6 080/083			●			060../L3	406080	406023	
				●		090../L1	409082	409020	
					●	120../L2	412082	412020	
FK 6 100/101/103				●		090../L2	409081	409024	
					●	120../L3	412081	412024	

\* Kein Siemens Kerntyp







# MOTOREN-APPLIKATION

## APPLICATION POUR DES MOTEURS MOTOR APPLICATIONS

Die Auflistung der Motoren erfolgt gemäss der Anbaubarkeit an die betreffende Getriebe-grösse.  
Für die korrekte Getriebeauslegung sind die Leistungstabellen massgebend.

Les moteurs sont classés selon la montabilité avec les tailles de réducteur.  
Pour la sélection du réducteur le tableau de caractéristiques est déterminant.

The motors are listed according to whether the units can be fitted to the gear box size.  
The correct power ratings have to be determined with the load tables.

		Baugrösse/Taille/Size					Type FA / FH / AE	Part No. 	Part No. 
		030	045	060	090	120			
Yaskawa	SGMP-01A3B4	●					030..	403090	403023
	SGMP-02A3B4	●					030..	403092	403020
			●				045/L1	404593	404521
	SGMP-04A3B4	●					030..	403092	403020
				●			045../L1	404593	404521
	SGMP-08A3B4			●			045../L2	404595	404525
	SGMP-15A3B4			●			045../L2	404595	404520
					●		060../L2	406091	406021
	SGMG-03A.B								
	-05A.A								
	-06A.B				●		060../L3	406092	406021
	-09A.A					●	090../L1	409091	409023
	SGMG-09A.B				●		060../L3	406092	406024
	-13A.A					●	090../L1	409091	ø22 409029
	SGMG-12A.B								
	-20A.A					●	090../L2	409092	409028
	-20A.B						120../L3	412090	412023
	-30A.A								
	-30A.B								
	-44A.A								
	SGMG-44A.B								
	-55A.A					●			
	-60A.B								
	-75A.A								
	-1AA.A								
	SGMS-10A.A								
	-15A.A				●		060../L2	406090	406020
	-20A.A					●	090../L1	409090	409022
	SG MS-30A.A								
	-40A.A				●		060../L3	406092	406026
-50A.A					●	090../L1	409091	409021	
SGMD-22A.AAB					●	090../L1	409093	409021	
SGMD-32A.AAB						120../L1	412091	412021	
SGMD-40A.AAB					●	090../L2	409093	409020	
						120../L2	412091	412020	

# ANWENDUNGEN

APPLICATIONS  
APPLICATIONS

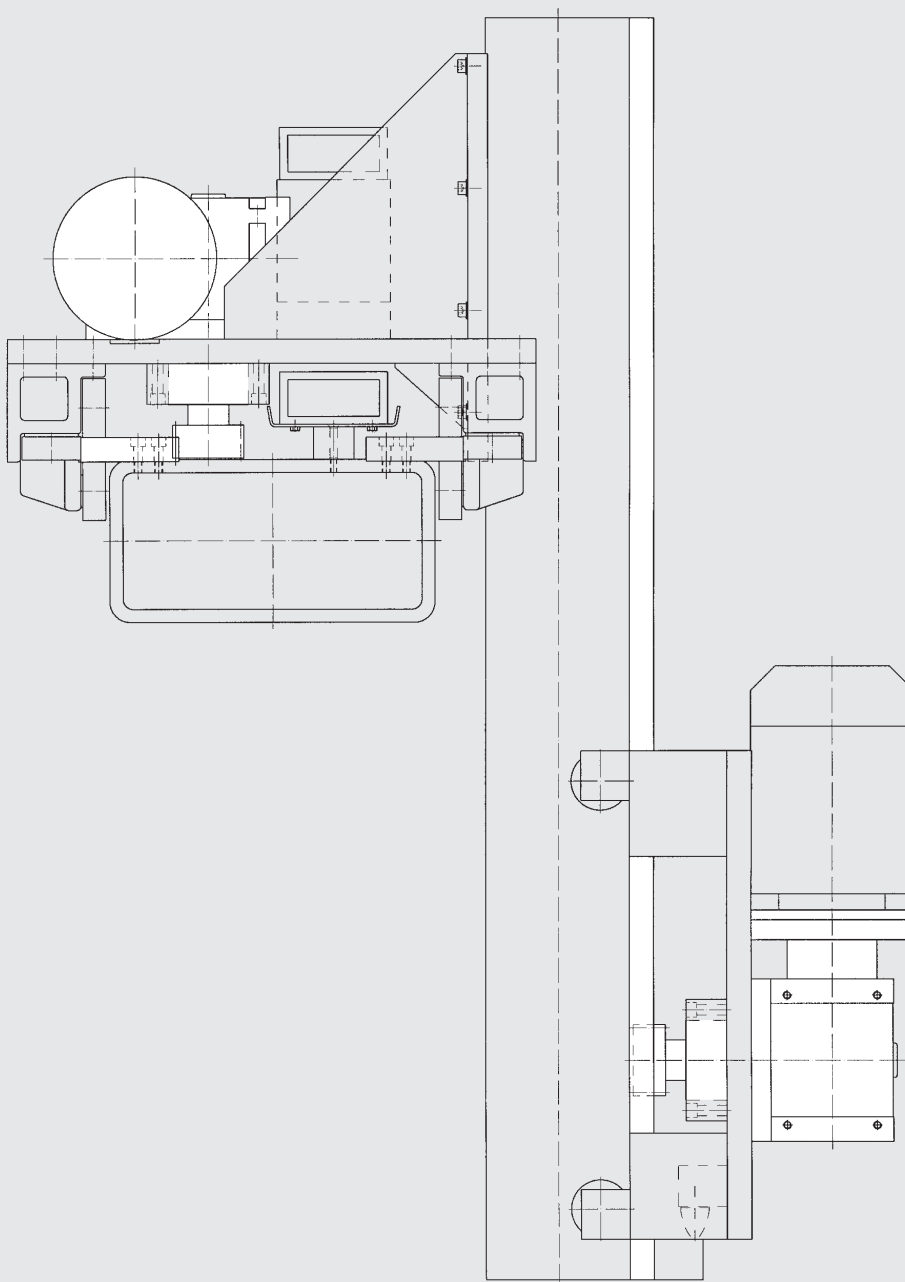
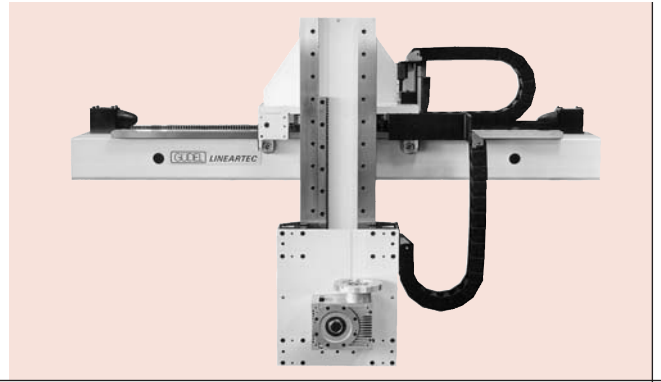

# ANWENDUNGEN

## APPLICATIONS APPLICATIONS

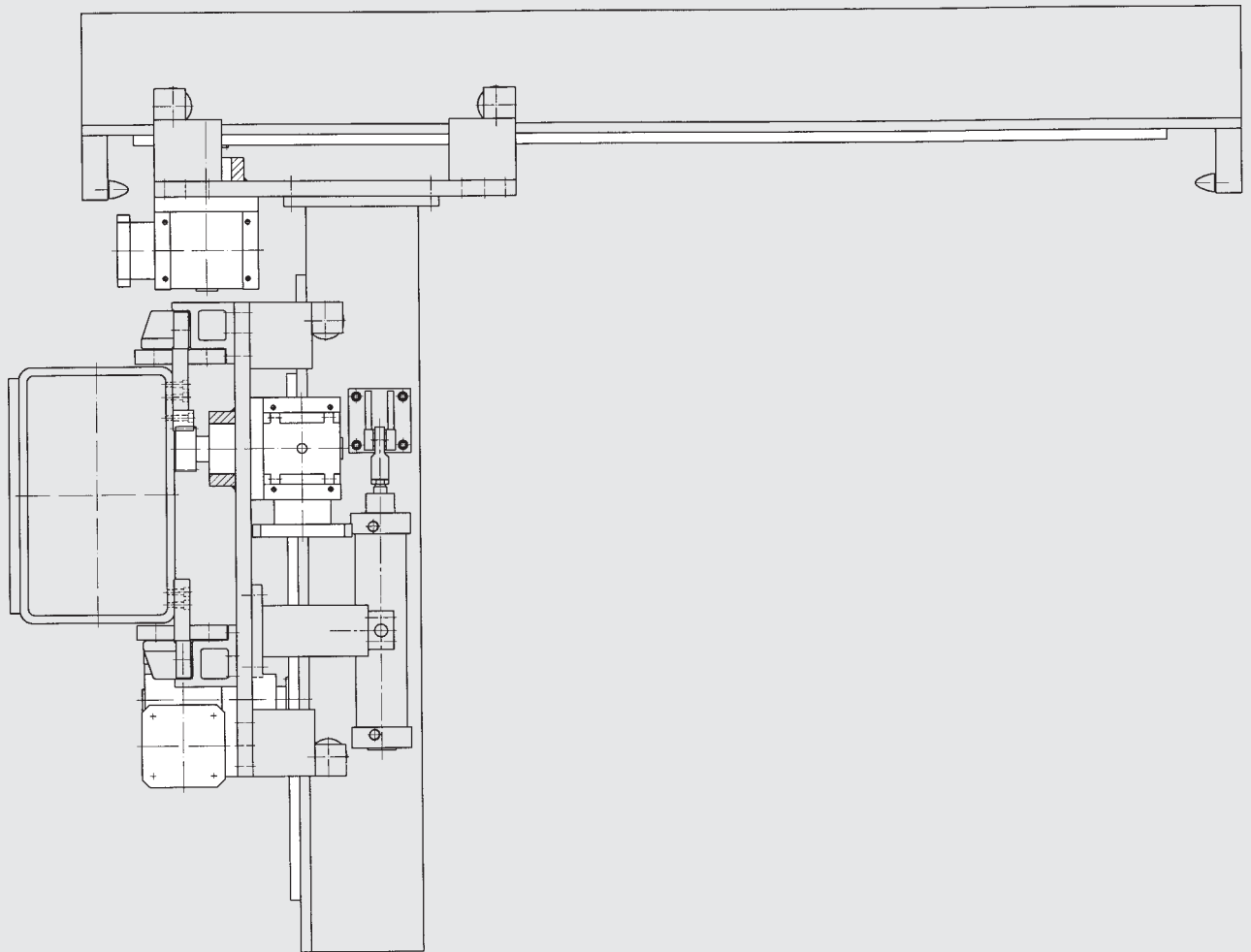
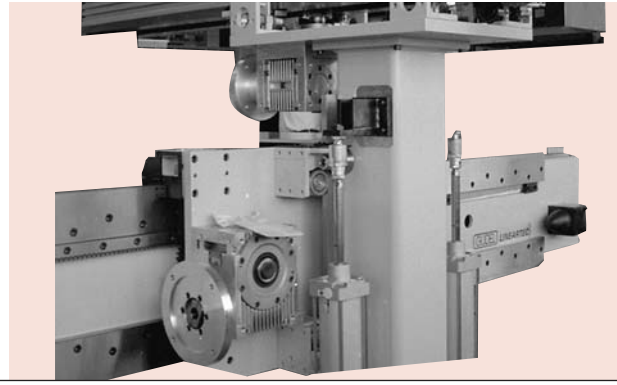

07.30

NEU: fast developer Testen Sie [www.gudel.com/fastdeveloper](http://www.gudel.com/fastdeveloper) : Getriebe online auslegen

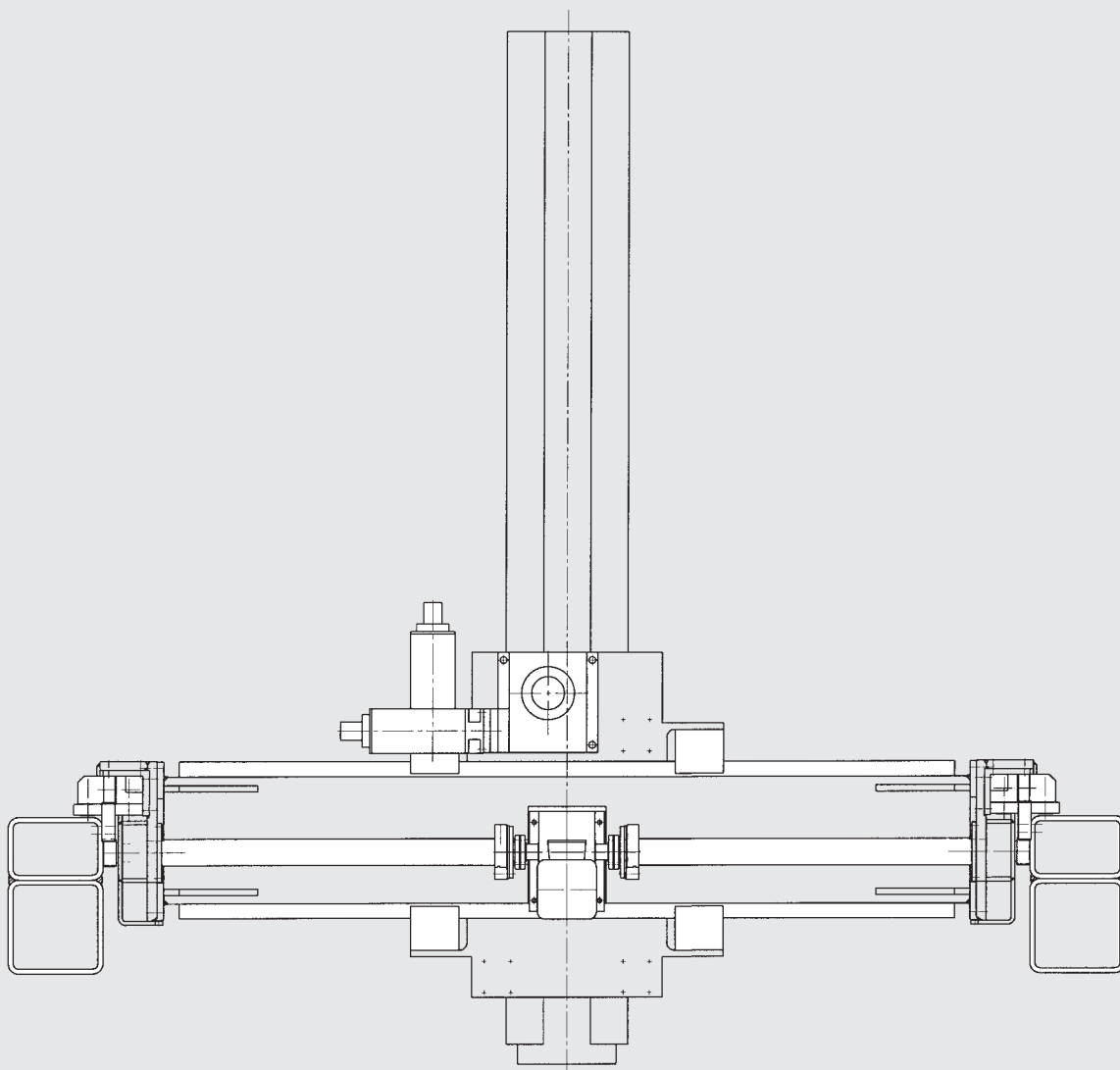
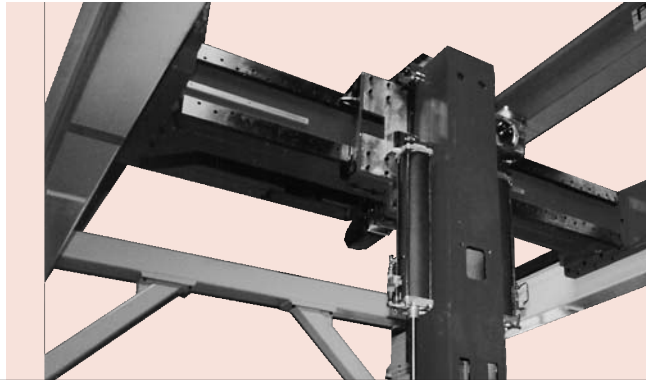

# GÜDEL

## Lieferumfang

Der vorliegende Katalog umfasst die Komponenten der Linear- und Antriebstechnik. Der Inhalt widerspiegelt die Erfahrung von mehr als 5 Jahrzehnten der Entwicklung und Fertigung von Längsführungen, Verzahnungen und Getriebebau.

Das nach ISO 9001: 2000 aufgebaute Qualitätssystem, eine grosse Lagerhaltung und ein weltweites Vertriebsnetz garantieren einen optimalen Kundennutzen.

Das umfangreiche Standardprogramm ermöglicht einen schnellen Zugriff auf alle Komponenten.

Ein erfahrenes Ingenieurteam hilft Ihnen bei der Auswahl, erarbeitet mit Ihnen Einbauvorschläge und optimiert Ihren Anwendungsfall. Auch Sonderteile nach Ihren Zeichnungen stellen wir gerne für Sie her. Sprechen Sie mit uns!

## Etendue de la livraison

Le catalogue suivant comprend les composants de la technique linéaire et d'entraînement. Le contenu reflète l'expérience de plus de 5 décennies de développement et de fabrication de guides longitudinaux, de dentures et de construction d'engrenages.

Le système de qualité élaboré selon ISO 9001: 2000, un stock important et un réseau de distribution mondial garantissent au client un profit optimal.

La riche gamme standard permet un accès rapide à tous les composants.

Une équipe d'ingénieurs expérimentés vous aidera à choisir, travaillera avec vous des projets de montage et optimisera votre cas d'application. Nous fabriquerons également des pièces spéciales pour vous selon vos dessins. Parlez-nous de vos applications!

## Scope of supply

This catalogue covers all the components of the linear and drive technology. Its content reflects the experience of more than 5 decades in the development and manufacture of linear guides, gears and gearboxes.

A quality system based on ISO 9001: 2000, a large inventory and a global distribution network guarantee optimal benefits to the customer. The extensive standard programme makes rapid access to all components possible at all times.

An experienced engineering team will help you in your selection, and assist you in drawing up installation proposals and in the optimisation of your application. We will also be pleased to manufacture custom components to your own drawings. Call us!

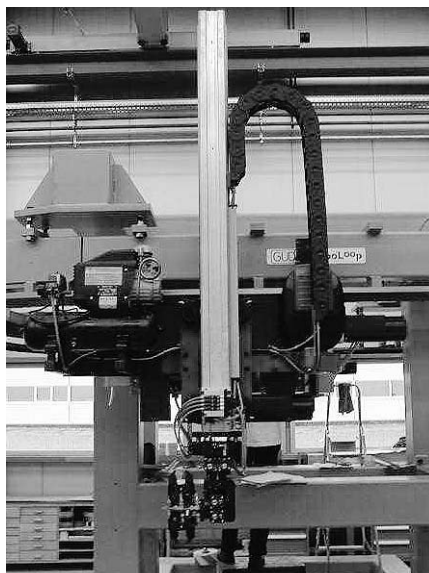
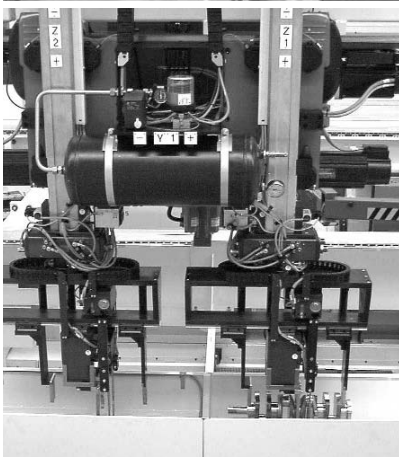





### Lieferumfang

### Etendue de la livraison

### Scope of supply

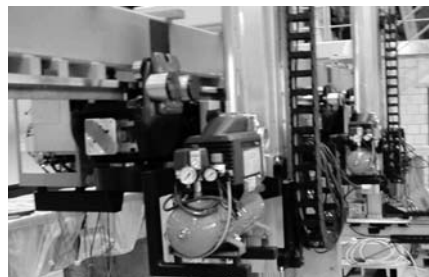
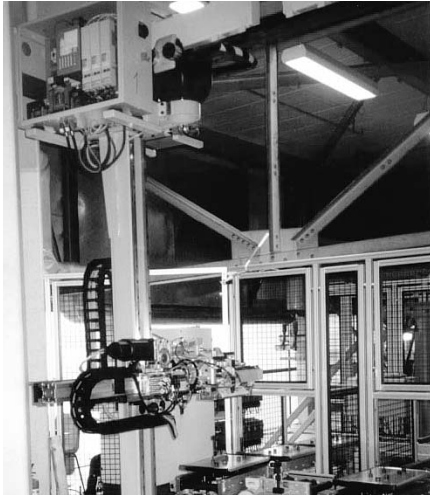
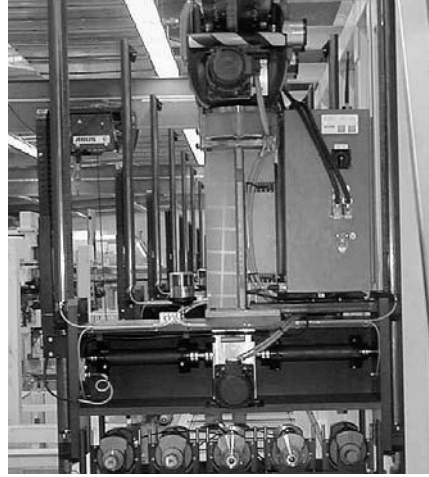

## www.gudel.com

Besuchen Sie uns im Internet.  
Unsere Web-Site www.gudel.com wurde  
völlig neu überarbeitet und bietet Ihnen  
folgende Möglichkeiten.

- Interessante Neuentwicklungen
- Produktübersicht
  - Komponenten
  - Module
  - Robotics
  - Systems
- Down-Load Funktionen für  
Zeichnungsunterlagen
- Anwendungsbeispiele
- Messdaten

## www.gudel.com

Nous vous invitons à vous connecter sur Internet.  
à l'adresse www.gudel.com  
Notre site a été refait complètement et vous  
offre les possibilités suivantes:

- Les nouveautés intéressantes
- Index des catalogues produits
  - composants
  - modules
  - robotics
  - systems
- Chargement des plans de nos produits.
- Applications
- Dates de nos participations aux différents  
Salons d'exposition.

## www.gudel.com

Visit us on our Homepage www.gudel.com  
Our web-site is completely reworked and  
offer you following possibilities:

- Interesting news
- Overall view of our catalogues
  - components
  - modules
  - robotics
  - systems
- Downloads of drawings
- Applications
- Dates of our exhibitions



**GÜDEL AG**

Industrie Nord  
CH-4900 Langenthal  
Switzerland  
phone +41 62 916 91 91  
fax +41 62 916 91 50  
eMail [info@ch.gudel.com](mailto:info@ch.gudel.com)  
[www.gudel.com](http://www.gudel.com)

**GÜDEL GmbH**

Carl-Benz-Strasse 5  
D-63674 Altenstadt  
Germany  
phone +49 6047 9639 0  
fax +49 6047 9639 90  
eMail [info@de.gudel.com](mailto:info@de.gudel.com)  
[www.gudel.com](http://www.gudel.com)

**GÜDEL Inc.**

4881 Runway Blvd.  
US-Ann Arbor, MI 48108  
USA  
phone +1 734 214 0000  
fax +1 734 214 9000  
eMail [info@us.gudel.com](mailto:info@us.gudel.com)  
[www.gudel.com](http://www.gudel.com)